

SUPER **High Performance**

➤ 3 Flute Solid Carbide
Coolant Fed Drills

designed for
Aluminum, Cast Irons & Titanium



Specialty Tools, Inc

3150 Colley Rd. Beloit, WI 53511 • Ph: 608.313.8730 • Fax: 608.313.8760

www.specialtytoolsinc.com

Table of Contents



- About our Company 3
- 2000-& 2002 Series Drills 4
- Drill EDP Numbers..... 6
- Speeds & Feeds Chart 10
- Setup & Available Coatings 11
- Recommended Drill Coatings 12
- STI Stock Coating: Futura Nano 13
- Optional High Performance Coating: Helica..... 14
- Resharpening Services..... 15
- Specials 16
- Quote Request & Ordering Information 17
- Troubleshooting 18
- The STI Advantage 19

➤ STI has been designing, manufacturing and reconditioning High Performance tools for more than 25 years.

We have served many satisfied customers in the automotive, aerospace, agricultural, medical and machine tool industries, including such fields but not limited to small and large engines, hydraulics and power train. Our reputation for quality, reliability and service is excellent and all of our products are designed, engineered and manufactured in the U.S.A

Three Flute Solid & Coolant Fed Tools

Our Performance 2000 and 2002 Series™ are an excellent choice for aluminum, cast iron, titanium and non-ferrous applications. Many standard sizes are stocked and ready for immediate delivery, however, we can design a drill specifically to meet your requirements with special diameters, flute and/or over-all lengths.

Grinding & Resharpening

In addition to producing and reconditioning our standard line of high performance carbide drills, we also recondition and sharpen all brands of High Performance Carbide Drills and High Performance Carbide End Mills to OEM specs with a 100% satisfaction guarantee.

Custom Tool Design & Manufacturing

Specialty Tool takes great pride in our exceptional delivery capabilities and competitive pricing on Solid Carbide round shank specials, such as step drills, end mills, port form cutters and step form reamers. STI's Tool Engineers and Application Specialists focus on building and designing cutting tools to best fit the machining or part application for special non standard tools. After all, "Specialty is in our name!"

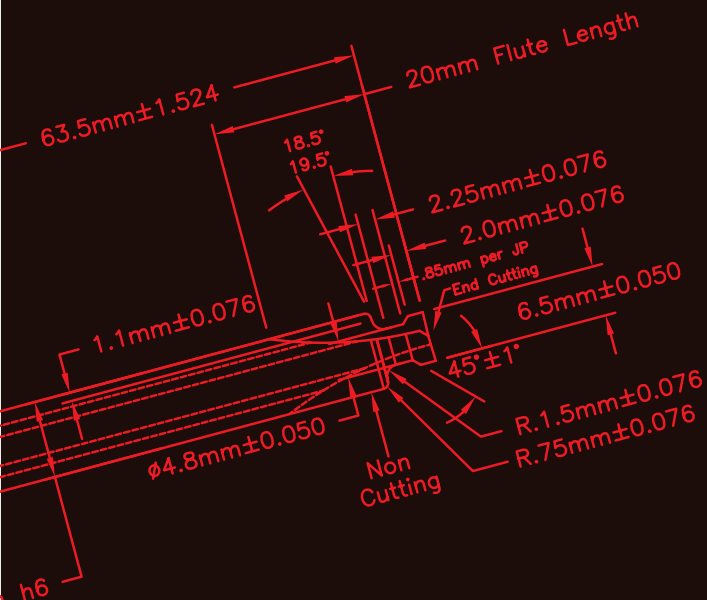
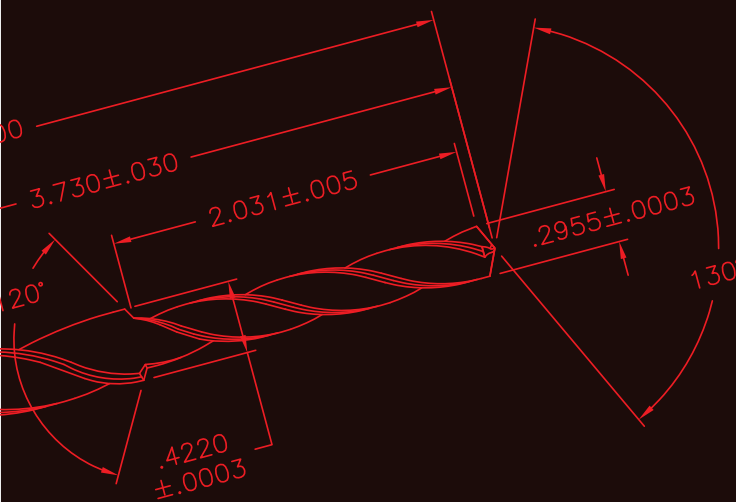

SUPER

High Performance

Series 2000
Non Coolant

Series 2002
Coolant Through



Our high precision three flute carbide drills provides unsurpassed performance for:

**Aluminum
Irons
Non Ferrous
Metals
and Titanium.**

Also suitable for
low carbon soft steels



Series 2000
Non Coolant

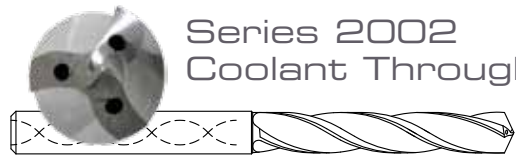

Series 2002
Coolant Through

Higher Speeds & Feeds=**Greater Productivity**

Greater Hole Accuracy=**Tighter Tolerances**

Longer Tool Life=**Lower Cost Per Hole**

STI's 2000 and 2002 series drills can increase the bottom line, and decrease costly production errors. While both drills are a high precision, three-flute design; the 2002 series contains patented helical coolant bores that deliver the coolant immediately to the cutting surface of the drill. Not only does this keep the cutting edge as cool as possible with added lubrication during the drilling process, but the coolant exerts direct hydraulic force on the shavings to help evacuate them out through the large flute gullets. This allows faster penetration rates & creates cleaner more accurate holes, in less time with less tool wear. vs.conventional 2 flute drills.



US patent #6,045,305 & #6,283,682 held and owned by STI

Three Cutting Edges

STI's 2000 & 2002 Series three-flute construction removes more material per revolution than traditional two-flute drills. In addition, the extra flute enables the drill to track straighter while in the hole. 3 contact points in the bore 120 degrees apart vs a 2 flute drill with 2 contact points 180 deg apart. The third land produces a quality surface finish, possibly eliminating the need to ream or bore separately after drilling. The three-flute design also allows the drill to start or end on uneven surfaces and to handle interrupted cuts with less deflection.

Self-Centering Point

The STI 2000 - 2002 Series actively cuts to the rotation centerline axis of the drill. This allows the drill to cut immediately upon contact with the surface of the material, thus eliminating the spotting or center drill operation entirely. The point angle aids in accommodating the third flute and contributes to the production of narrower chips.

High Quality Material and Construction

STI's 2000 & 2002 Series drills are made for optimum performance in high volume CNC machining applications. The solid carbide material of the 2000 Series and 2002 Series with coolant-through are made from ultra fine grain premium grade carbide substrate for optimal toughness and wear resistance.

Stock Availability & Coatings

2000 & 2002 Series drills are available in any size from .182" to .787" and any flute length up to 8". STI can also accommodate any diameter, flute length and overall length (within our range). Plus, STI offers a full line of advanced thin film coatings to enhance performance.

> Drill Specs

Series 2000 Non Coolant
Series 2002 Coolant Through

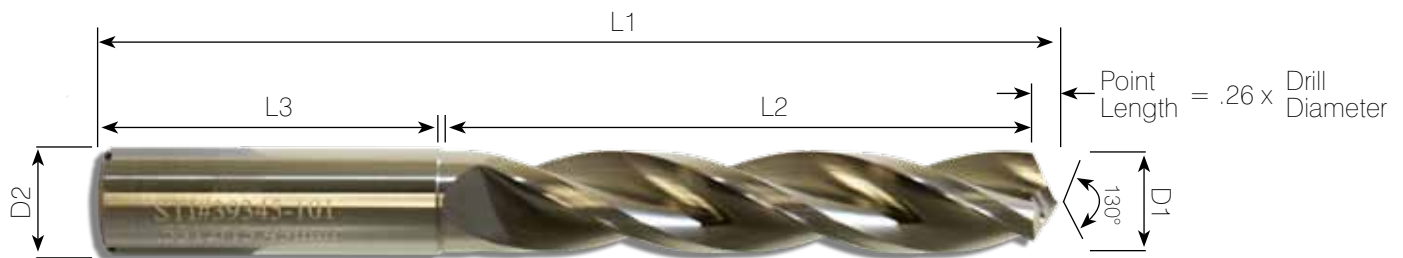

Tap Drill Size	Drill Diameter			EDP# Series 2000 Non Coolant Bright	EDP # Series 2000 Non-Coolant Balinit® Futura Nano	EDP# Series 2002 Coolant Through Bright	EDP# Series 2002 Coolant Through Balinit® Futura Nano	Shank Diameter	Shank Length	Overall Length	Flute Length
	Metric	Decimal	Fr / Ltr / #					D2	L3	L1	L2
M5x0.8 Form 69%	4.62	0.1820	14	1820-5XN-00	1820-5XN-03	1820-5XC-00	1820-5XC-03	.2362" 6mm	1.40" 35.5mm	3.00" 76.2mm	1.40" 35.5mm
	4.76	0.1875	3/16	1875-5XN-00	1875-5XN-03	1875-5XC-00	1875-5XC-03				
	4.80	0.1890	12	1890-5XN-00	1890-5XN-03	1890-5XC-00	1890-5XC-03				
	4.85	0.1910	11	1910-5XN-00	1910-5XN-03	1910-5XC-00	1910-5XC-03				
	4.91	0.1935	10	1935-5XN-00	1935-5XN-03	1935-5XC-00	1935-5XC-03				
	4.98	0.1960	9	1960-5XN-00	1960-5XN-03	1960-5XC-00	1960-5XC-03				
M6x1.0	5.00	0.1969		1969-5XN-00	1969-5XN-03	1969-5XC-00	1969-5XC-03				
	5.06	0.1990	8	1990-5XN-00	1990-5XN-03	1990-5XC-00	1990-5XC-03				
1/4-20	5.11	0.2010	7	2010-5XN-00	2010-5XN-03	2010-5XC-00	2010-5XC-03				
	5.16	0.2031	13/64	2031-5XN-00	2031-5XN-03	2031-5XC-00	2031-5XC-03				
	5.18	0.2040	6	2040-5XN-00	2040-5XN-03	2040-5XC-00	2040-5XC-03				
	5.22	0.2055	5	2055-5XN-00	2055-5XN-03	2055-5XC-00	2055-5XC-03				
	5.31	0.2090	4	2090-5XN-00	2090-5XN-03	2090-5XC-00	2090-5XC-03				
	5.41	0.2130	3	2130-5XN-00	2130-5XN-03	2130-5XC-00	2130-5XC-03				
	5.50	0.2165		2165-5XN-00	2165-5XN-03	2165-5XC-00	2165-5XC-03				
M6x1.0 Form 71%	5.51	0.2170		2170-5XN-00	2170-5XN-03	2170-5XC-00	2170-5XC-03				
	5.56	0.2188	7/32	2188-5XN-00	2188-5XN-03	2188-5XC-00	2188-5XC-03				
	5.61	0.2210	2	2210-5XN-00	2210-5XN-03	2210-5XC-00	2210-5XC-03				
1/4-20 Form 70%	5.74	0.2260		2260-5XN-00	2260-5XN-03	2260-5XC-00	2260-5XC-03				
	5.79	0.2280	1	2280-5XN-00	2280-5XN-03	2280-5XC-00	2280-5XC-03				
1/4-28 Form 70%	5.91	0.2330		2330-5XN-00	2330-5XN-03	2330-5XC-00	2330-5XC-03				
	5.94	0.2340	A	2340-5XN-00	2340-5XN-03	2340-5XC-00	2340-5XC-03				
	5.95	0.2344	15/64	2344-5XN-00	2344-5XN-03	2344-5XC-00	2344-5XC-03				
M7x1.0	6.00	0.2362		2362-5XN-00	2362-5XN-03	2362-5XC-00	2362-5XC-03				
	6.05	0.2380	B	2380-5XN-00	2380-5XN-03	2380-5XC-00	2380-5XC-03				
	6.15	0.2420	C	2420-5XN-00	2420-5XN-03	2420-5XC-00	2420-5XC-03				
	6.248	0.2460	D	2460-5XN-00	2460-5XN-03	2460-5XC-00	2460-5XC-03				
	6.35	0.2500	1/4; E	2500-5XN-00	2500-5XN-03	2500-5XC-00	2500-5XC-03				
	6.50	0.2559		2559-5XN-00	2559-5XN-03	2559-5XC-00	2559-5XC-03				
	5/16-18	6.53	0.2570	F	2570-5XN-00	2570-5XN-03	2570-5XC-00	2570-5XC-03			
		6.63	0.2610	G	2610-5XN-00	2610-5XN-03	2610-5XC-00	2610-5XC-03			
		6.70	0.2638		2638-5XN-00	2638-5XN-03	2638-5XC-00	2638-5XC-03			
		6.746	0.2656	17/64	2656-5XN-00	2656-5XN-03	2656-5XC-00	2656-5XC-03			
		6.76	0.2660	H	2660-5XN-00	2660-5XN-03	2660-5XC-00	2660-5XC-03			
	5/16-24	6.91	0.2720	I	2720-5XN-00	2720-5XN-03	2720-5XC-00	2720-5XC-03			

See page 11 for additional coating options.



Series 2000 Non Coolant
Series 2002 Coolant Through

Tap Drill Size	Drill Diameter			EDP# Series 2000 Non Coolant Bright	EDP # Series 2000 Non-Coolant Balinit® Futura Nano	EDP# Series 2002 Coolant Through Bright	EDP# Series 2002 Coolant Through Balinit® Futura Nano	Shank Diameter D2	Shank Length L3	Overall Length L1	Flute Length L2
	D1										
	Metric	Decimal	Fr / Ltr / #								
M8x1.0	7.00	0.2756		2756-5XN-00	2756-5XN-03	2756-5XC-00	2756-5XC-03	.3150" 8mm	1.40" 35.5mm	3.25" 82.5mm	1.60" 40.6mm
	7.04	0.2770	J	2770-5XN-00	2770-5XN-03	2770-5XC-00	2770-5XC-03				
	7.137	0.2810	K	2810-5XN-00	2810-5XN-03	2810-5XC-00	2810-5XC-03				
	7.14	0.2812	9/32	2812-5XN-00	2812-5XN-03	2812-5XC-00	2812-5XC-03				
	7.20	0.2835		2835-5XN-00	2835-5XN-03	2835-5XC-00	2835-5XC-03				
5/16-18 Form 70%	7.26	0.2860		2860-5XN-00	2860-5XN-03	2860-5XC-00	2860-5XC-03				
	7.37	0.2900	L	2900-5XN-00	2900-5XN-03	2900-5XC-00	2900-5XC-03				
M8x1.25 Form 71%	7.39	0.2910		2910-5XN-00	2910-5XN-03	2910-5XC-00	2910-5XC-03				
5/16-24 Form 69%	7.44	0.2930		2930-5XN-00	2930-5XN-03	2930-5XC-00	2930-5XC-03				
	7.49	0.2950	M	2950-5XN-00	2950-5XN-03	2950-5XC-00	2950-5XC-03				
	7.50	0.2953		2953-5XN-00	2953-5XN-03	2953-5XC-00	2953-5XC-03				
M8x1.0 Form 70%	7.52	0.2960		2960-5XN-00	2960-5XN-03	2960-5XC-00	2960-5XC-03				
	7.54	0.2969	19/64	2969-5XN-00	2969-5XN-03	2969-5XC-00	2969-5XC-03				
	7.67	0.3020	N	3020-5XN-00	3020-5XN-03	3020-5XC-00	3020-5XC-03				
	7.80	0.3071		3071-5XN-00	3071-5XN-03	3071-5XC-00	3071-5XC-03				
	7.90	0.3110		3110-5XN-00	3110-5XN-03	3110-5XC-00	3110-5XC-03				
3/8-16	7.94	0.3125	5/16	3125-5XN-00	3125-5XN-03	3125-5XC-00	3125-5XC-03				
	8.00	0.3150		3150-5XN-00	3150-5XN-03	3150-5XC-00	3150-5XC-03				
	8.03	0.3160	O	3160-5XN-00	3160-5XN-03	3160-5XC-00	3160-5XC-03				
	8.20	0.3228		3228-5XN-00	3228-5XN-03	3228-5XC-00	3228-5XC-03				
	8.204	0.3230	P	3230-5XN-00	3230-5XN-03	3230-5XC-00	3230-5XC-03				
	8.33	0.3281	21/64	3281-5XN-00	3281-5XN-03	3281-5XC-00	3281-5XC-03				
3/8-24	8.43	0.3320	Q	3320-5XN-00	3320-5XN-03	3320-5XC-00	3320-5XC-03				
M10x1.5	8.50	0.3346		3346-5XN-00	3346-5XN-03	3346-5XC-00	3346-5XC-03				
	8.60	0.3386		3386-5XN-00	3386-5XN-03	3386-5XC-00	3386-5XC-03				
	8.61	0.3390	R	3390-5XN-00	3390-5XN-03	3390-5XC-00	3390-5XC-03				
	8.70	0.3425		3425-5XN-00	3425-5XN-03	3425-5XC-00	3425-5XC-03				
	8.73	0.3438	11/32	3438-5XN-00	3438-5XN-03	3438-5XC-00	3438-5XC-03				
3/8-16 Form 71%	8.76	0.3450		3450-5XN-00	3450-5XN-03	3450-5XC-00	3450-5XC-03				
	8.84	0.3480	S	3480-5XN-00	3480-5XN-03	3480-5XC-00	3480-5XC-03				
	8.90	0.3504		3504-5XN-00	3504-5XN-03	3504-5XC-00	3504-5XC-03				
	9.00	0.3543		3543-5XN-00	3543-5XN-03	3543-5XC-00	3543-5XC-03				
3/8-24 Form 71%	9.02	0.3550		3550-5XN-00	3550-5XN-03	3550-5XC-00	3550-5XC-03				
	9.09	0.3580	T	3580-5XN-00	3580-5XN-03	3580-5XC-00	3580-5XC-03				
	9.13	0.3594	23/64	3594-5XN-00	3594-5XN-03	3594-5XC-00	3594-5XC-03				
M10x1.5 Form 71%	9.27	0.3650		3650-5XN-00	3650-5XN-03	3650-5XC-00	3650-5XC-03				
7/16-14	9.35	0.3680	U	3680-5XN-00	3680-5XN-03	3680-5XC-00	3680-5XC-03				
M10x1.25 Form 71%	9.40	0.3700		3700-5XN-00	3700-5XN-03	3700-5XC-00	3700-5XC-03				

See page 11 for additional coating options.

Series 2000 Non Coolant
Series 2002 Coolant Through



Tap Drill Size	Drill Diameter			EDP# Series 2000 Non Coolant Bright	EDP # Series 2000 Non-Coolant Balinit® Futura Nano	EDP# Series 2002 Coolant Through Bright	EDP# Series 2002 Coolant Through Balinit® Futura Nano	Shank Diameter	Shank Length	Overall Length	Flute Length
	D1							D2	L3	L1	L2
	Metric	Decimal	Fr / Ltr / #								
	9.50	0.3740		3740-5XN-00	3740-5XN-03	3740-5XC-00	3740-5XC-03	.3937" 10mm	1.60" 40.6mm	4.00" 101.6mm	2.20" 55.8mm
	9.53	0.3750	3/8	3750-5XN-00	3750-5XN-03	3750-5XC-00	3750-5XC-03				
	9.58	0.3770	V	3770-5XN-00	3770-5XN-03	3770-5XC-00	3770-5XC-03				
	9.70	0.3819		3819-5XN-00	3819-5XN-03	3819-5XC-00	3819-5XC-03				
	9.804	0.3860	W	3860-5XN-00	3860-5XN-03	3860-5XC-00	3860-5XC-03				
7/16-20	9.92	0.3906	25/64	3906-5XN-00	3906-5XN-03	3906-5XC-00	3906-5XC-03				
	10.00	0.3937		3937-5XN-00	3937-5XN-03	3937-5XC-00	3937-5XC-03				
	10.08	0.3970	X	3970-5XN-00	3970-5XN-03	3970-5XC-00	3970-5XC-03				
	10.20	0.4016		4016-5XN-00	4016-5XN-03	4016-5XC-00	4016-5XC-03				
M12x1.75 7/16-14 Form 70%	10.26	0.4040	Y	4040-5XN-00	4040-5XN-03	4040-5XC-00	4040-5XC-03				
	10.32	0.4062	13/32	4062-5XN-00	4062-5XN-03	4062-5XC-00	4062-5XC-03				
	10.49	0.4130	Z	4130-5XN-00	4130-5XN-03	4130-5XC-00	4130-5XC-03				
7/16-20 Form 71%	10.50	0.4134		4134-5XN-00	4134-5XN-03	4134-5XC-00	4134-5XC-03				
1/2-13	10.72	0.4219	27/64	4219-5XN-00	4219-5XN-03	4219-5XC-00	4219-5XC-03				
M12x1.25	10.80	0.4252		4252-5XN-00	4252-5XN-03	4252-5XC-00	4252-5XC-03				
	11.00	0.4331		4331-5XN-00	4331-5XN-03	4331-5XC-00	4331-5XC-03				
	11.11	0.4375	7/16	4375-5XN-00	4375-5XN-03	4375-5XC-00	4375-5XC-03				
M12x1.75 Form 71%	11.15	0.4390		4390-5XN-00	4390-5XN-03	4390-5XC-00	4390-5XC-03				
M12x1.25 Form 70%	11.40	0.4490		4490-5XN-00	4490-5XN-03	4490-5XC-00	4490-5XC-03				
	11.50	0.4528		4528-5XN-00	4528-5XN-03	4528-5XC-00	4528-5XC-03				
1/2-20	11.51	0.4531	29/64	4531-5XN-00	4531-5XN-03	4531-5XC-00	4531-5XC-03				
1/2-13 Form 70%	11.76	0.4630		4630-5XN-00	4630-5XN-03	4630-5XC-00	4630-5XC-03				
	11.91	0.4688	15/32	4688-5XN-00	4688-5XN-03	4688-5XC-00	4688-5XC-03				
	12.00	0.4724		4724-5XN-00	4724-5XN-03	4724-5XC-00	4724-5XC-03				
1/2-20 Form 71%	12.09	0.4760		4760-5XN-00	4760-5XN-03	4760-5XC-00	4760-5XC-03				
9/16-12	12.30	0.4844	31/64	4844-5XN-00	4844-5XN-03	4844-5XC-00	4844-5XC-03				
M14x1.5	12.50	0.4921		4921-5XN-00	4921-5XN-03	4921-5XC-00	4921-5XC-03				
	12.70	0.5000	1/2	5000-5XN-00	5000-5XN-03	5000-5XC-00	5000-5XC-03				
	13.00	0.5118		5118-5XN-00	5118-5XN-03	5118-5XC-00	5118-5XC-03				
9/16-18	13.10	0.5156	33/64	5156-5XN-00	5156-5XN-03	5156-5XC-00	5156-5XC-03				
9/16-12 Form 70%	13.28	0.5230		5230-5XN-00	5230-5XN-03	5230-5XC-00	5230-5XC-03				
M14x1.5 Form 70%	13.28	0.5230		5230-5XN-00	5230-5XN-03	5230-5XC-00	5230-5XC-03				
M14x1.25 Form 69%	13.41	0.5280		5280-5XN-00	5280-5XN-03	5280-5XC-00	5280-5XC-03				
	13.49	0.5312	17/32	5312-5XN-00	5312-5XN-03	5312-5XC-00	5312-5XC-03				
5/8-11	13.50	0.5315		5315-5XN-00	5315-5XN-03	5315-5XC-00	5315-5XC-03				
9/16-18 Form 70%	13.61	0.5360		5360-5XN-00	5360-5XN-03	5360-5XC-00	5360-5XC-03				
	13.89	0.5469	35/64	5469-5XN-00	5469-5XN-03	5469-5XC-00	5469-5XC-03				
M16x2.0	14.00	0.5512		5512-5XN-00	5512-5XN-03	5512-5XC-00	5512-5XC-03				



Series 2000 Non Coolant
Series 2002 Coolant Through

Tap Drill Size	Drill Diameter			EDP# Series 2000 Non Coolant Bright	EDP # Series 2000 Non-Coolant Balinit® Futura Nano	EDP# Series 2002 Coolant Through Bright	EDP# Series 2002 Coolant Through Balinit® Futura Nano	Shank Diameter D2	Shank Length L3	Overall Length L1	Flute Length L2
	D1										
	Metric	Decimal	Fr / Ltr / #								
	14.29	0.5625	9/16	5625-5XN-00	5625-5XN-03	5625-5XC-00	5625-5XC-03	.6299" 16mm	1.80" 45.7mm	5.25" 133.3mm	3.25" 82.5mm
M16x1.5	14.50	0.5709		5709-5XN-00	5709-5XN-03	5709-5XC-00	5709-5XC-03				
5/8-18	14.68	0.5781	37/64	5781-5XN-00	5781-5XN-03	5781-5XC-00	5781-5XC-03				
5/8-11 Form 71%	14.76	0.5810		5810-5XN-00	5810-5XN-03	5810-5XC-00	5810-5XC-03				
	15.00	0.5906		5906-5XN-00	5906-5XN-03	5906-5XC-00	5906-5XC-03				
M16X2.0 Form 71%	15.04	0.5920		5920-5XN-00	5920-5XN-03	5920-5XC-00	5920-5XC-03				
	15.08	0.5938	19/32	5938-5XN-00	5938-5XN-03	5938-5XC-00	5938-5XC-03				
5/8-18 Form 71%	15.12	0.5980		5980-5XN-00	5980-5XN-03	5980-5XC-00	5980-5XC-03				
M16x1.5 Form 69%	15.29	0.6020		6020-5XN-00	6020-5XN-03	6020-5XC-00	6020-5XC-03				
	15.48	0.6094	39/64	6094-5XN-00	6094-5XN-03	6094-5XC-00	6094-5XC-03				
M18x2.5	15.50	0.6102		6102-5XN-00	6102-5XN-03	6102-5XC-00	6102-5XC-03				
	15.88	0.6250	5/8	6250-5XN-00	6250-5XN-03	6250-5XC-00	6250-5XC-03				
	16.00	0.6299		6299-5XN-00	6299-5XN-03	6299-5XC-00	6299-5XC-03				
	16.27	0.6406	41/64	6406-5XN-00	6406-5XN-03	6406-5XC-00	6406-5XC-03				
M18x1.5	16.50	0.6496		6496-5XN-00	6496-5XN-03	6496-5XC-00	6496-5XC-03	.7087" 18mm	1.90" 48.2mm	5.63" 143.0mm	3.50" 89.0mm
3/4-10	16.67	0.6562	21/32	6562-5XN-00	6562-5XN-03	6562-5XC-00	6562-5XC-03				
	17.00	0.6693		6693-5XN-00	6693-5XN-03	6693-5XC-00	6693-5XC-03				
	17.07	0.6719	43/64	6719-5XN-00	6719-5XN-03	6719-5XC-00	6719-5XC-03				
M18x1.5 Form 71%	17.27	0.6800		6800-5XN-00	6800-5XN-03	6800-5XC-00	6800-5XC-03				
3/4-16	17.46	0.6875	11/16	6875-5XN-00	6875-5XN-03	6875-5XC-00	6875-5XC-03				
M20x2.5	17.50	0.6890		6890-5XN-00	6890-5XN-03	6890-5XC-00	6890-5XC-03				
3/4-10 Form 69%	17.86	0.7031	45/64	7031-5XN-00	7031-5XN-03	7031-5XC-00	7031-5XC-03				
	18.00	0.7087		7087-5XN-00	7087-5XN-03	7087-5XC-00	7087-5XC-03				
	18.26	0.7188	23/32	7188-5XN-00	7188-5XN-03	7188-5XC-00	7188-5XC-03				
3/4-16 Form 70%	18.29	0.7200		7200-5XN-00	7200-5XN-03	7200-5XC-00	7200-5XC-03				
M20x1.5	18.50	0.7283		7283-5XN-00	7283-5XN-03	7283-5XC-00	7283-5XC-03				
	18.65	0.7344	47/64	7344-5XN-00	7344-5XN-03	7344-5XC-00	7344-5XC-03				
	19.00	0.7480		7480-5XN-00	7480-5XN-03	7480-5XC-00	7480-5XC-03				
	19.05	0.7500	3/4	7500-5XN-00	7500-5XN-03	7500-5XC-00	7500-5XC-03				
M20x1.5	19.28	0.7590		7590-5XN-00	7590-5XN-03	7590-5XC-00	7590-5XC-03				
7/8-9	19.45	0.7656	49/64	7656-5XN-00	7656-5XN-03	7656-5XC-00	7656-5XC-03				
M22x2.5	19.50	0.7677		7677-5XN-00	7677-5XN-03	7677-5XC-00	7677-5XC-03				
	19.84	0.7812	25/32	7812-5XN-00	7812-5XN-03	7812-5XC-00	7812-5XC-03				
	20.00	0.7874		7874-5XN-00	7874-5XN-03	7874-5XC-00	7874-5XC-03				

> Speeds & Feeds

STARTING PARAMETERS

2000-Series - Non Coolant **External Coolant**

Workpiece Material	BHN	Balinit® Futura Nano Balinit® Helica (sfm)	Bright TiCN (sfm)	Feed in inches per Revolution for Drill Diameter					
				0.187 (3 mm)	0.250 (6 mm)	0.375 (10 mm)	0.500 (13 mm)	0.625 (16 mm)	0.750+ (19 mm)
Gray Cast Iron	<180	300 - 400	200 - 250	.005-.008	.007-.010	.009-.012	.011-.015	.016-.018	.017-.022
	>180	250 - 300	175 - 200	.003-.006	.005-.008	.007-.010	.009-.013	.014-.016	.015-.018
Nodular Iron / Ductile Iron	<220	250 - 300	200 - 250	.004-.007	.005-.008	.008-.011	.010-.015	.014-.018	.018-.022
	>220	180 - 220	150 - 175	.003-.004	.004-.006	.006-.009	.009-.013	.012-.016	.014-.018
Aluminum Alloys		900 - 1000	600 - 800	.004-.006	.007-.011	.010-.015	.013-.018	.017-.022	.022-.030
Aluminum: > 9% Si		700 - 800	600 - 700	.004-.006	.007-.011	.010-.015	.013-.018	.017-.022	.022-.030
Brass/Bronze/Copper	<220	200 - 300	150 - 250	.003-.004	.004-.007	.005-.008	.007-.010	.011-.015	.014-.018
Magnesium Alloys		900 - 1000	600 - 800	.004-.006	.007-.011	.010-.015	.013-.018	.017-.022	.022-.030
Soft Titanium Alloys	<300	130 - 160	75 - 100	.002-.003	.003-.004	.004-.006	.005-.007	.007-.009	.009-.012
Plastics		250 - 275	250 - 275	.002-.005	.006-.008	.007-.010	.009-.012	.011-.015	.015-.020
Soft Low Carbon Steels	<220	250 - 300	150 - 250	.003-.004	.004-.006	.007-.009	.010-.014	.015-.018	.016-.020

2002 Series - Coolant Through **Internal Coolant**

Workpiece Material	BHN	Balinit® Futura Nano Balinit® Helica (sfm)	Bright TiCN (sfm)	Feed in inches per Revolution for Drill Diameter					
				0.187 (3 mm)	0.250 (6 mm)	0.375 (10 mm)	0.500 (13 mm)	0.625 (16 mm)	0.750+ (19 mm)
Gray Cast Iron	<180	400 - 500	250 - 300	.005-.008	.007-.010	.009-.012	.011-.015	.016-.018	.017-.022
	>180	300 - 400	200 - 250	.003-.006	.005-.008	.007-.010	.009-.013	.014-.016	.015-.018
Nodular Iron / Ductile Iron	<220	400 - 500	225 - 275	.004-.007	.005-.008	.008-.011	.010-.015	.014-.018	.018-.022
	>220	300 - 400	175 - 200	.003-.004	.004-.006	.006-.009	.009-.013	.012-.016	.014-.018
Aluminum Alloys		1200 - 1400	800 - 1200	.004-.006	.007-.011	.010-.015	.013-.018	.017-.022	.022-.030
Aluminum: > 9% Si		900 - 1000	700 - 800	.004-.006	.007-.011	.010-.015	.013-.018	.017-.022	.022-.030
Brass/Bronze/Copper	<220	350 - 400	200 - 300	.003-.004	.004-.007	.005-.008	.007-.010	.011-.015	.014-.018
Magnesium Alloys		1200 - 1400	800 - 1200	.004-.006	.007-.011	.010-.015	.013-.018	.017-.022	.022-.030
Soft Titanium Alloys	<300	160 - 275	100 - 130	.002-.003	.003-.004	.004-.006	.005-.007	.007-.009	.009-.012
Plastics		300 - 350	300 - 350	.002-.005	.006-.008	.007-.010	.009-.012	.011-.015	.015-.020
Soft Low Carbon Steels	<220	300 - 500	180 - 250	.003-.004	.004-.006	.007-.009	.010-.014	.015-.018	.016-.020

RPM=SFPM x 3.82 ÷ diameter in.

> Set-Up

Cutting Fluids

Recommend a semi synthetic or a water soluble type at 8-10% concentration

Tool Holding

Important to keep the total indicated value within a .0008"

First choice: Hydraulic chuck or shrink fit holders

Second choice: Precision collet chuck

In order to achieve best performance of hole quality and tool life check the spindle condition, fixturing and clamping of the piece part for rigidity. Always keep overhang to a minimum.

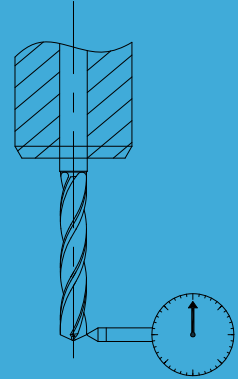

> Available Coatings

We use and recommend Balzers Balinit® coatings

STI Coating Code	Coating Material	Microhardness (HV 0.05)	Friction coefficient against steel (dry)	Max. service temperature (°C)	Coating color
01	TiN	2,300	0.4	600	gold-yellow
02	TiCN	3,000	0.4	400	blue-grey
05	ZrN	2,000	0.4	550	pale yellow
03	Balinit® Futura Nano	3,300	0.30 - 0.35	900	violet-grey
16	AlCrN	3,200	0.35	1,100	blue-grey
17	Balinit® Helica	3,000	0.25	1,100	copper
19	Diamond Like Coating (DLC)	2,500	0.10 - 0.20	350	black

STOCK COATING
for 2000 & 2002 series

With a short lead time, you can select a non-stock coating for 2000 & 2002 series tools. Simply add the 2 digit STI coating code (found on available coating table on pg 11) to EDP# as shown:

N specifies Series 2000 Non Coolant

C specifies Series 2002 Coolant Through

STI Coating Code

3740-5X **N** - **16**

We will accommodate any custom coating request. To specify a coating not listed above, call customer service at 608-313-8730.

> Choosing A Coating



A couple thousandths of a millimeter make all the difference.

Extremely thin but harder than steel, low friction coatings are extremely wear-resistant and chemically inert. The material and properties of coatings can be selected to match your specific requirements.

Material

Recommended Coatings for Drilling

	low silicon to high silicon				
	Bright	ZrN	TiCN	Balinit® Futura Nano	Diamond Like Coating
Aluminum					
	as speed increases				
Irons				Balinit® Futura Nano	AICrN Balinit® Helica
Low Carbon Steels				Balinit® Futura Nano	Balinit® Helica
Titanium Alloys				Balinit® Futura Nano	Balinit® Helica
Copper, Brass/Bronze Alloy				Balinit® Futura Nano	Balinit® Helica

> Coating For A Broad Range of Materials

STI STOCK COATING

BALINIT® FUTURA NANO: Premium TiAlN Based Coating

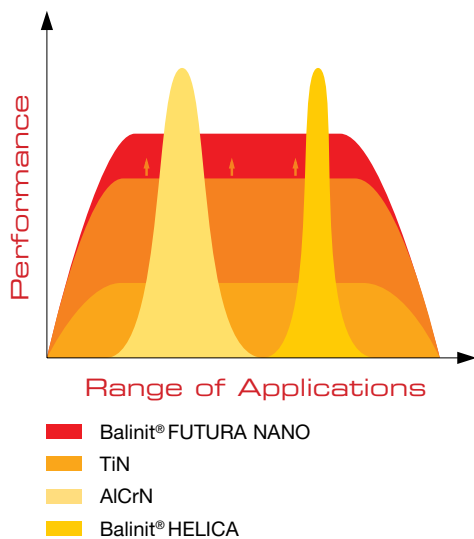

The optimized relationship of hardness and residual compressive stress of the Balinit® Futura Nano titanium aluminium nitride coating increases the stability of the cutting edges of machining tools.

Its outstanding thermal and chemical resistance permit dry cutting and improvements in performance of highly stressed components. The high hardness of the coating gives outstanding protection against abrasive wear and erosion.

Drilling

Wear curve, V_b [mm]

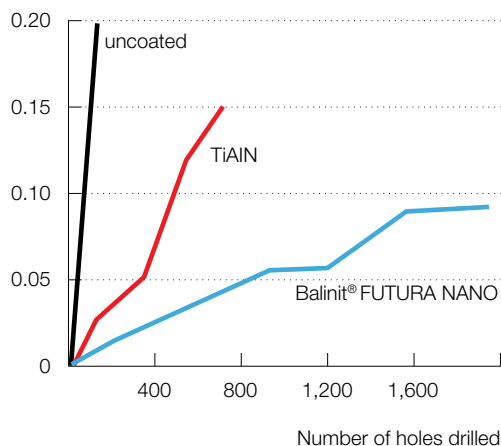

Tool:

Solid carbide twist drill,
Ø 6.8 mm

Workpiece:

Steel DIN 1.1191 (~AISI
1045)

Speeds and feeds:

Into solid material
34mm deep (blind hole)
 $v_c = 120$ m/min
 $f = 0.2$ mm/rev
External cooling,
without lifting



uncoated, after 15 holes



Balinit® FUTURA NANO,
after 2,000 holes



TiAlN, after 750 holes

We stock 2000 and 2002 series drills in Balinit® Futura Nano. Have your coated tool shipped same day!

> Coating For Optimum Drilling Performance

BALINIT® HELICA: High Performance AlCrN Based Coating

Balinit® Helica, an AlCrN-based coating, has made it possible to systematically optimize and decisively improve the key coating properties for drilling applications.

Greater abrasion resistance, extra shear strength, lower adhesion tendency, maximum toughness and a very smooth surface achieve a quantum leap in drilling performance.

The superior properties of this new coating generation have been optimised especially for drills. The above advantages fully come to the fore with solid carbide drills, whether cooling is external or internal. In all common steel and cast iron qualities, Balinit® Helica affords virtually unlimited drill performance, even in the challenging operation of deep-hole drilling with twist drills.

The extra-smooth surfaces of Balinit® Helica-coated drills mean smooth, reliable chip evacuation from the entire hole - a must if you want to exploit the full potential of your drills.

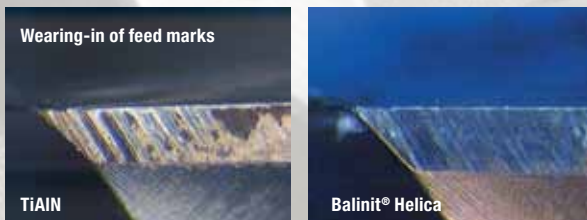

homogeneous wear, no wearing-in of feed marks, high corner stability and shear strength: excellent conditions for multiple regrinding and recoating.

Enhanced stability of cutting edge corner

Width of wear land VB [µm]

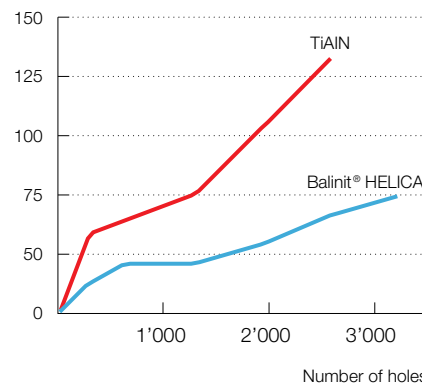

Tool:
Solid carbide twist drill,
Ø 6.8 mm
Workpiece:
Steel DIN 1.1191 (~AISI 1045)

Cutting data:
 $v_c = 120$ m/min, $f = 0.2$ mm/rev
Hole depth 5xD, External cooling
Source:
Oerlikon Balzers
cutting laboratory

Drilling in Cast Iron

Cutting speed v_c [m/min]

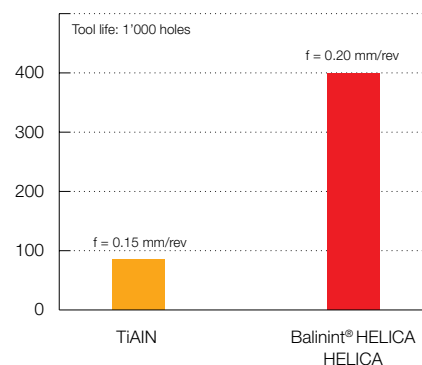

Tool:
Solid carbide twist drill,
Ø 6 mm
Workpiece:
Steel DIN 1.1191 (~AISI 1045)

Cutting data:
 $v_c = 80$ m/min, $f = 0.16$ mm/rev,
Hole depth 4xD, Internal cooling
with emulsion
Source:
Tool manufacturer

> Resharpening Services



“STI regrinds give us as much or more holes than our new Sandvik Delta C.”

Artec Precision

“We get 3,000 - 4,000 inches with the new ‘Titex’ in 304 S.S., STI regrind give me 5,000 - 7,000 inches.”

Enerquip

Customers can expect up to 70%-90% tool life vs. original tool.

STI utilizes the latest software for sharpening all new high performance drill geometries for many brands. Our state of the art CNC grinders are recognized world wide as leading tool grinding technology. Our like new condition and huge cost savings versus buying new will impress operators and management—guaranteed!

We sharpen ALL high performance brands. One P.O. One Source!



> Specials

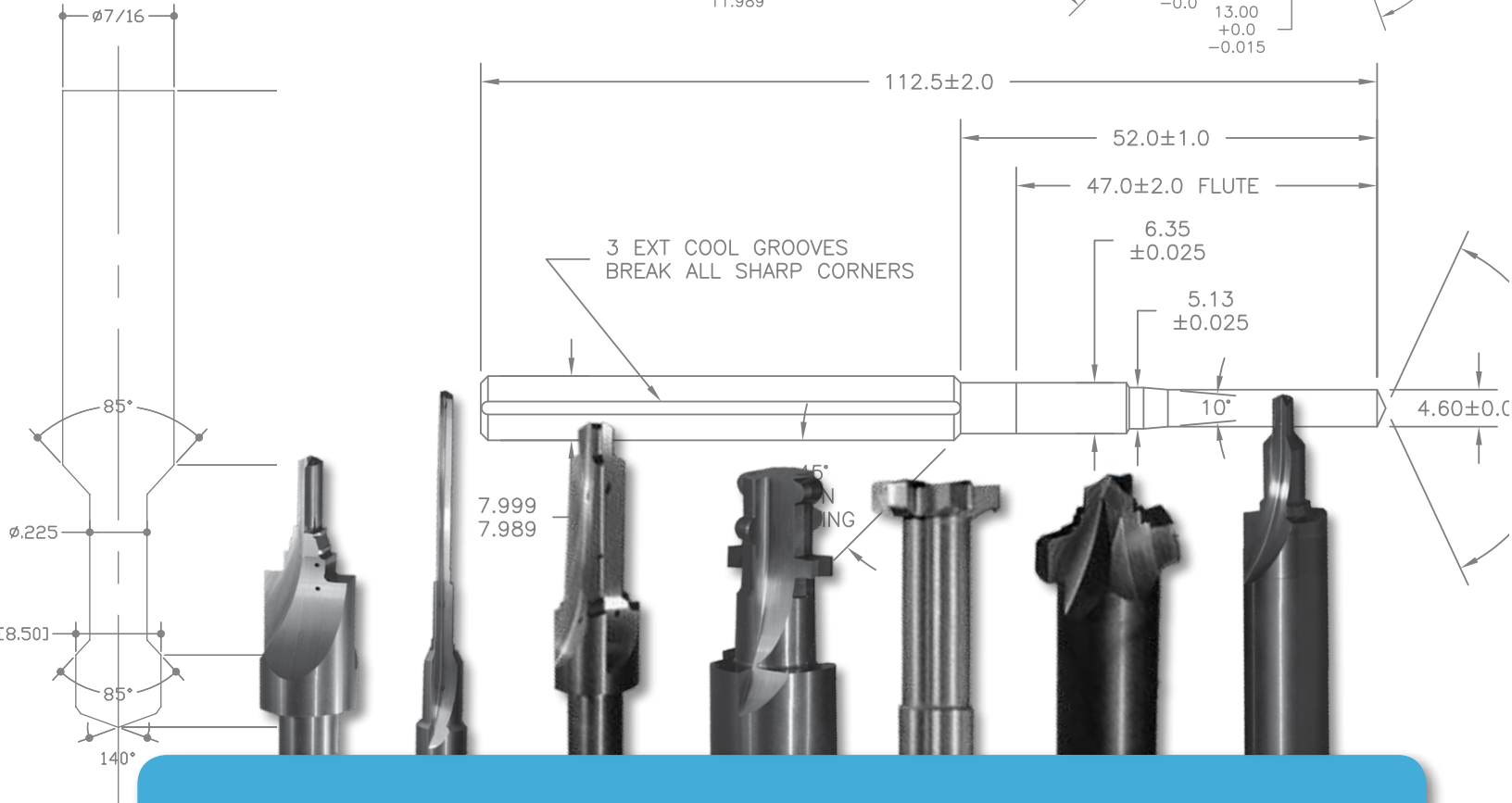
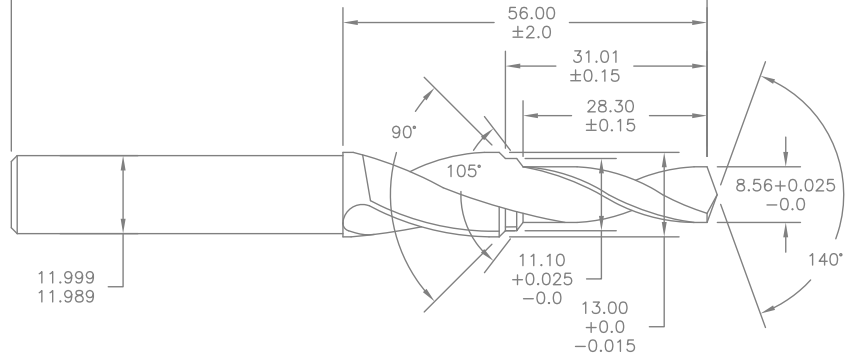

Step Drills, Form Mills, Port Form Cutters, Step Form Reamers...

If you need a special tool, look no further than Specialty Tools. Our solid carbide round shank specials are given the exact same attention to detail during production as our drill series. Our tool engineers use the latest software to ensure the most precise machining. Plus, we focus on designing tools that fit your machining process as well as the specific application.

After all, "Specialty" is our first name!

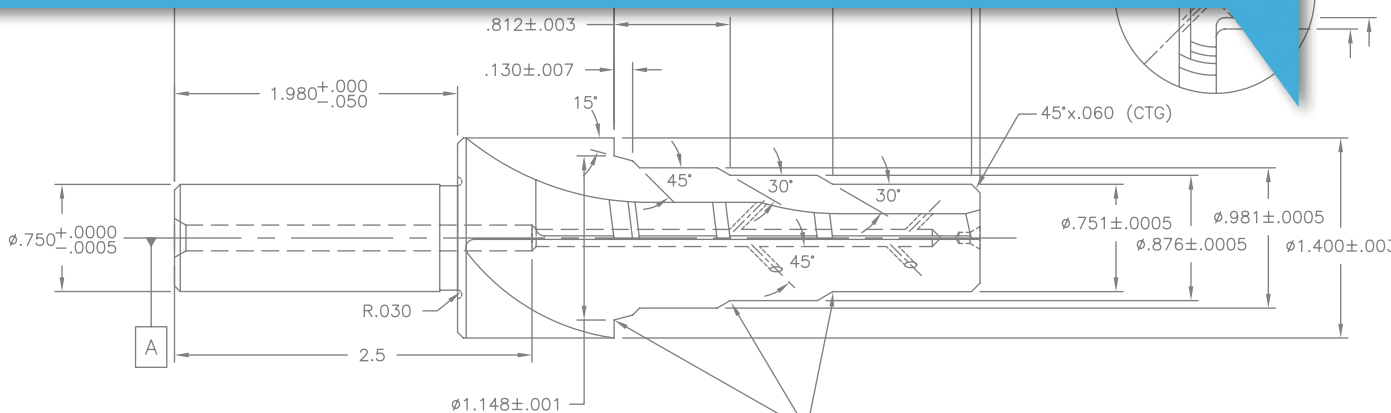
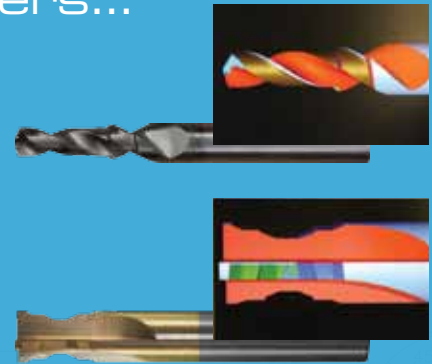

Ordering Information

Requesting a Quote for Specials

You can find our easy, quick, fill in the blank forms for simple step drills on our website at: www.specialtytoolsinc.com.

Need a custom tool? Email your tool drawing or part print to: quotes@specialtytoolsinc.com or contact your sales person by calling 608.313.8730.

The image displays five Specialty Tools Inc. form sheets for requesting quotes for various drill types. Each form includes contact information, a 'TOLERANCES' table, technical diagrams, and fields for specifying tool parameters like diameters, lengths, and angles.

Specialty Tools Inc.
3150 Colley Road Beloit, WI 53511
Ph: (608) 313-8730 Fax: (608) 313-8760
Email: stt@specialtytoolsinc.com

Double Step Drill
Print for Quote # _____ Date: _____
Distributor: _____
Dist Contact: _____
End User: _____
User Contact: _____
Tool Number: _____
Revision: _____
TOLERANCES
Shank Diameter $\pm 0.0005''$
Cutting Diameter $\pm 0.0005''$
Step Lengths $\pm 0.0005''$
Flute Length & OAL $\pm 0.0005''$
Angles ± 1.000
Check Hole Style Below
of Flutes _____ Overall Length (L1) _____
Shank Ø (D) _____ Flute Length (L2) _____
Major Drill Ø (D1) _____ 1st Step Length (L3) _____
1st Step Ø (D3) _____ 2nd Step Length (L4) _____
2nd Step Ø (D2) _____ 1st Incl Step Angle (A1) _____
Point Angle (A) _____ 2nd Incl Step Angle (A2) _____
Coolant Non Coolant
Coating: None TiN TiCN TiAlN
Material to be Machined: _____

Drill
Print for Quote # _____ Date: _____
Distributor: _____
Dist Contact: _____
End User: _____
User Contact: _____
Tool Number: _____
Revision: _____
TOLERANCES
Shank Diameter $\pm 0.0005''$
Cutting Diameter $\pm 0.0005''$
Flute Length & OAL $\pm 0.0005''$
Angles ± 1.000
Use Geometry: Perf 1000/1002 Style Perf 2000/2002 Style Perf 3000/3002 Style
of Flutes _____ Overall Length (L1) _____
Drill Ø (D1) _____ Flute Length (L2) _____
Shank Ø (D2) _____ Shank Length (L3) _____
Point Angle (A) _____
Coolant Non Coolant
Coating: None TiN TiCN TiAlN
Material to be Machined: _____
Additional Information: _____

Specialty Tools Inc.
3150 Colley Road Beloit, WI 53511
Ph: (608) 313-8730 Fax: (608) 313-8760
Email: stt@specialtytoolsinc.com

End Mill/ Ball Nose End Mill
Print for Quote # _____ Date: _____
Distributor: _____
Dist Contact: _____
End User: _____
User Contact: _____
Tool Number: _____
Revision: _____
TOLERANCES
Shank Diameter $\pm 0.0005''$
Cutting Diameter $\pm 0.0005''$
Length of Cut & OAL $\pm 0.0005''$
Radius & Chamfer $\pm 0.0005''$
End Type: Ball Square
of Flutes _____ Overall Length (L) _____
Shank Ø (D) _____ Length of Cut (L1) _____
Cutting Ø (D1) _____ Rad. or Chf. (R/C) _____
Coolant Non Coolant
Coating: None TiN TiCN TiAlN
Material to be Machined: _____
Additional Information: _____

Specialty Tools Inc.
3150 Colley Road Beloit, WI 53511
Ph: (608) 313-8730 Fax: (608) 313-8760
Email: stt@specialtytoolsinc.com

Reverse Chamfer Drill
Print for Quote # _____ Date: _____
Distributor: _____
Dist Contact: _____
End User: _____
User Contact: _____
Tool Number: _____
Revision: _____
TOLERANCES
Shank Diameter $\pm 0.0005''$
Cutting Diameter $\pm 0.0005''$
Step Lengths $\pm 0.0005''$
Flute Length & OAL $\pm 0.0005''$
Angles ± 1.000
Hole Style Below Drill & Chamfer
of Flutes _____ 2nd Chamfer Angle (A2) _____
Shank Ø (D) _____ Overall Length (L1) _____
Neck Ø (D1) _____ Flute Length (L2) _____
Major Drill Ø (D2) _____ Length to 2nd Chf. (L3) _____
Point Angle (A) _____ Length to 1st Chf. (L4) _____
1st Chf. Angle (A1) _____
Coolant Non Coolant
Coating: None TiN TiCN TiAlN
Material to be Machined: _____
Additional Information: _____

Specialty Tools Inc.
3150 Colley Road Beloit, WI 53511
Ph: (608) 313-8730 Fax: (608) 313-8760
Email: stt@specialtytoolsinc.com

Single Step Drill
Print for Quote # _____ Date: _____
Distributor: _____
Dist Contact: _____
End User: _____
User Contact: _____
Tool Number: _____
Revision: _____
TOLERANCES
Shank Diameter $\pm 0.0005''$
Cutting Diameter $\pm 0.0005''$
Step Lengths $\pm 0.0005''$
Flute Length & OAL $\pm 0.0005''$
Angles ± 1.000
Check Hole Style Below Drill & Chamfer or Chf.
of Flutes _____ Overall Length (L1) _____
Shank Ø (D) _____ Flute Length (L2) _____
Major Drill Ø (D1) _____ Step Length (L3) _____
Step Ø (D2) _____ Point Angle (A) _____
Incl Step Angle (A1) _____
Coolant Non Coolant
Coating: None TiN TiCN TiAlN
Material to be Machined: _____
Additional Information: _____

> Troubleshooting



Cutting edge build up

Increase the cutting speed
Increase the coolant concentration and or pressure or flow
(use water soluble or semi synthetic type fluid)

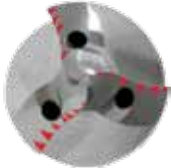

Chipping on the drill lip

Check machine spindle and tool holder
Check the clamping of the part and fixture
Reduce the feed rate



Excessive outer drill lip wear

Reduce the cutting speed
Increase the feed rate
Check the machine spindle and tool holder
Check the clamping of the part and fixture
Increase the coolant concentration and or pressure or flow
(use water soluble or semi synthetic type fluid)



Chipping the outer corners of drill lip

Check the machine spindle and tool holder
Check the clamping of the part or fixture
Reduce the feed rate



Excessive wear on periphery land

Reduce the cutting speed
Check the machine spindle and tool holder
Check the clamping of the part and fixture
Increase the coolant concentration and/or flow pressure
(use water soluble or semi synthetic type fluid)

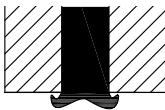

Heavy burr at breakthrough

Reduce the feed rate

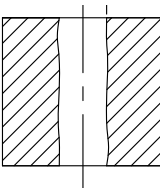

Poor surface finish

Check the machine spindle and tool holder
Check for chip smear or chip welding on periphery lands
Increase the coolant concentration and/or flow pressure
(use water soluble or semi synthetic type fluid)

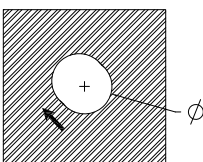

Poor hole position/poor hole tolerance

Check the machine spindle and tool holder
Check for chip smear or chip welding on periphery lands
Reduce feed rate
Start on machined flat surface
Increase the coolant concentration and/or flow pressure
(use water soluble or semi synthetic type fluid)



> Providing high quality tooling with excellent service at a cost that represents great value.

Great Equipment

We start by exclusively using Walter Helitronic grinders – the bench mark for all other grinding machines. Our Walters give us the flexibility to provide a wide variety of precise, cost effective cutting tools for our customers.

Great Creativity

Then we use a dose of good old fashioned innovation. STI holds two patents for our 3 flute coolant through drills. Why buy an inferior design when you the customer can be more efficient with our application designed products or our coolant through 3 flute drills.

Great People

Finally and most importantly, we have the best people. From our engineers to operating technicians to our front office. STI prides itself on having a core staff dedicated to one mission: “Being of great value and a partner with our customers”.



need more information
on tool resharpening?



request our
regrinding brochure
by calling
608.313.8730



Specialty Tools, Inc

3150 Colley Rd. Beloit, WI 53511 • Ph: 608.313.8730 • Fax: 608.313.8760
www.specialtytoolsinc.com

Distributed By: