



ADVENT
TOOL & MANUFACTURING INC.

Specializing in Solid & Replaceable
Thread and Form Mill Tooling

2022

adventtoolusa.com

847-395-9707



MISSION STATEMENT

*It is the primary goal of
Advent Tool & Manufacturing, Inc.
to supply machine shops and
manufacturers across the globe
with thread mills, designed and
manufactured to specifically meet
their machining needs, focusing on
job adaptability, superior quality
materials, longer tool life,
and faster cycle times.*

Thread Milling now takes a front seat
in modern machining centers worldwide!

Helical Interpolation is a standard feature
and high performance form milling is
within your reach.

Advent Tool & Manufacturing is the
leading global manufacturer and supplier
of solid carbide, carbide inserted thread
mills, and custom form mill tooling.

Advent's first consideration is the
customer's needs and continually strives
to meet market demands. Advent prides
itself on the fact that there is no order too
big or too small, and every customer is
worth the best our staff has to offer.



ADVENT TOOL CATALOG

Table of Contents

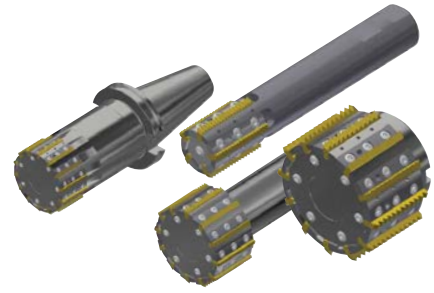

Technical Information	Page 2-6	Straight Shank/Weldon Replaceable Insert Quad Mills	Page 35
Replaceable Insert Thread Mill Designation	Page 7	Integral Shank C50 Replaceable Insert Quad Mills	Page 36
Replaceable Insert Thread Mills: Standard Size- Multi-Flute	Page 8	Quad Mill: Replacement Parts	Page 37
Replaceable Insert Thread Mills: Metric Size- Multi-Flute	Page 9	Quad Mill Insert Designation	Page 38
Replaceable Insert Thread Mills: High Pressure Version	Page 10	Quad Mill Inserts	Page 39-40
Integral Shank Replaceable Insert Thread Mills	Page 11	Solid Carbide Thread Mill Designation	Page 41
Shell Mill Replaceable Insert Thread Mills	Page 12	Solid Carbide Straight Flute (UN) Thread Mills	Page 42-44
Lathe Tooling	Page 13	Solid Carbide Straight Flute (M) Metric Thread Mills	Page 45
GT Indexable Tooling (GENERATION TWO) With Double Sided Inserts	Page 14	Solid Carbide Straight Flute (NPT) Thread Mills	Page 46
Face Grooving Tools	Page 15	Solid Carbide Straight Flute (NPTF & NPSF) Thread Mills	Page 47
Replaceable Insert Mills: Replaceable Parts	Page 16	Solid Carbide Straight Flute (BSPP) Thread Mills	Page 48
Coatings Available	Page 17	Solid Carbide Straight Flute (BSPT) Thread Mills	Page 49
Thread Mill Insert Designation	Page 18	Solid Carbide Helical (UN) Internal & External Thread Mills	Page 50
ATM-38A (UN) Thread Inserts	Page 19	Solid Carbide Helical (M) Metric Internal & External Thread Mills	Page 51
ATM-38B (UN) Thread Inserts	Page 20	Solid Carbide Helical (M) Metric Internal & External, Metric Shank Thread Mills	Page 52
ATM-410A (UN) Thread Inserts	Page 21-22	Solid Carbide Helical (NPT) Thread Mills	Page 53
ATM-38A & ATM38B (M) Metric Thread Inserts	Page 23	Solid Carbide Helical (BSPP & BSPT) Thread Mills	Page 54
ATM-410A (M) Metric Thread Inserts	Page 24	Solid Carbide Extended Length High Helix, Coolant Thru (K) Thread Mills	Page 55-56
Skipped Tooth (E2) UN & Metric Inserts	Page 25	Solid Carbide Extended Length E2 & E3 Thread Mill Designation	Page 57
Full Acme (FA) Internal & External Thread Inserts	Page 26	Solid Carbide Extended Length E2 & E3 (UN) Thread Mills	Page 58
Stub Acme (SA) Thread Inserts	Page 27	Single Point Tools	Page 59-61
NPT Thread Inserts	Page 28		
NPTF Thread Inserts	Page 29		
NPS Thread Inserts	Page 30		
NPSF Thread Inserts	Page 31		
BSPP & BSPT Thread Inserts	Page 32		
API & Buttress Thread Inserts	Page 33		
Quad Mill Designation	Page 34		

TECHNICAL INFORMATION

Thread Milling requires the use of a machining center capable of *Helical Interpolation*.

Your machine must be capable of three axes working in simultaneous movement with two axes performing circular interpolation, while the third moves perpendicular to the circular plane. (On most CNC controls this is achieved with a G02, or a G03 code)

Other factors to consider when using a Thread Mill are fixturing and tool length extension.

- The cutting action of a Thread Mill differs greatly from that of tapping; the more rigidly the part is fastened to the fixture the faster you can Thread Mill.
- The speeds and feeds are maximized when vibration of the part and fixture is minimized.
- Speeds and feeds are reduced depending on the distance a tool is held from the spindle face.
- A positive lock end mill style holder is always recommended.
- Never use a collet style holder for Thread Mills.
- Consider the rigidity of your fixture, and the distance of the tool from gauge line when threadmilling.

FEED RATE CALCULATION

- Due to the circular motion of the cutter as it forms a thread, the actual feed rate at the cutting edge will be different from that which is programmed at the center of the tool.
- For an internal thread, the feed rate at the edge increases as the cutter diameter increases.
- For an external thread, the feed rate at the edge decreases as the cutter diameter increases.
- There is a direct correlation between the size of the circle the cutter moves around and the size of the circle cut.

$$\text{Internal thread: } F1 = \frac{FL \times (Dw - Dc)}{Dw}$$

$$\text{External thread: } F1 = \frac{FL \times (Dw + Dc)}{Dw}$$

Where:

F1 = Programmed feed rate at the tool center (in/min)

FL = Actual feed rate at the cutting edge

Dw = Diameter of the work piece, or thread diameter

Dc = Cutter diameter

The actual feed rate is calculated using the standard formula:

$$FL = (\text{RPM}) \times (\text{Chip load}) \times (\text{No. of teeth})$$

THREAD MILL PROGRAMMING

Internal Threads (climb milling)

The simplest method to produce a thread form using an Advent Thread Mill is as follows:

1. The center of the hole being the X-Y zero point. Move the cutter to the center of the hole, then to the thread depth required.
2. Move the cutter over a small distance (usually about .02" towards the six-o'clock position to call up your cutter compensation.
3. Machine in a counter-clockwise direction generating a 1/2 circle and ending at the full thread depth at the twelve o'clock position. Simultaneously moving 1/2 pitch in the Z direction. The direction of the Z movement will determine the handedness of the thread.
4. Produce your thread by generating 1 full circle (counter-clockwise) around the center, while moving 1 full pitch in the Z direction.
5. After the full form has been machined, return to your starting position near the center of the hole. This is done by generating another 1/2 circle (counter-clockwise) combined with a 1/2 pitch move in Z direction.
6. Return to your hole center and exit the hole.

RECOMMENDED STARTING CUTTING CONDITIONS

Material	Material Hardness (BHN)	Material Machinability	SFM	Solid Carbide Chipload Per Flute (Feed in Inches) Tool Diameter								Replaceable Insert Thread Mill Chipload Per Flute (Feed in Inches) Tool Diameter						
				1/8"	3/16"	1/4"	5/16"	3/8"	1/2"	5/8"	3/4" +	3/8"	1/2"-3/4"	3/4"-1"	1"- 1 1/2"	1 1/2"-2"	2"- 2 3/4"	2 3/4"+
				Titanium Alloys Annealed, Alloys STA	320-370	Difficult	110-150	0.0003-	0.0003-	0.0005-	0.0005-	0.0010-	0.0010-	0.0010-	0.0020-	0.0003-	0.0003-	0.0005-
	375-420	Difficult	80-100	0.0006	0.0008	0.0010	0.0012	0.0020	0.0020	0.0020	0.0030	0.0006	0.0008	0.0010	0.0012	0.0020	0.0020	0.0030
Free Machining Steel 1118, 1215, 12L14	100-150	Easy	900	0.0004	0.0005	0.0007	0.0009	0.0010	0.0015	0.0020	0.0025	0.0008	0.0010	0.0012	0.0015	0.0020	0.0025	0.0030
	150-200	Easy	700	0.0004	0.0005	0.0007	0.0009	0.0010	0.0015	0.0020	0.0025	0.0008	0.0010	0.0012	0.0015	0.0020	0.0025	0.0030
	200-250	Easy	500	0.0004	0.0005	0.0007	0.0009	0.0010	0.0015	0.0020	0.0025	0.0008	0.0010	0.0012	0.0015	0.0020	0.0025	0.0030
Low Carbon Steel 1010, 1020, 1025, 1522, 1144	85-125	Average	900	0.0004	0.0005	0.0007	0.0009	0.0010	0.0015	0.0020	0.0025	0.0008	0.0010	0.0012	0.0015	0.0020	0.0025	0.0030
	125-175	Average	700	0.0004	0.0005	0.0007	0.0009	0.0010	0.0015	0.0020	0.0025	0.0008	0.0010	0.0012	0.0015	0.0020	0.0025	0.0030
	175-225	Average	600	0.0004	0.0005	0.0007	0.0009	0.0010	0.0015	0.0020	0.0025	0.0008	0.0010	0.0012	0.0015	0.0020	0.0025	0.0030
	225-275	Average	500	0.0004	0.0005	0.0007	0.0009	0.0010	0.0015	0.0020	0.0025	0.0008	0.0010	0.0012	0.0015	0.0020	0.0025	0.0030
Medium Carbon Steel 1010, 1040, 1050, 1527, 1140	175-225	Average	575	0.0004	0.0005	0.0006	0.0008	0.0010	0.0013	0.0018	0.0020	0.0008	0.0009	0.0010	0.0012	0.0015	0.0020	0.0025
	225-275	Average	500	0.0004	0.0005	0.0006	0.0008	0.0010	0.0013	0.0018	0.0020	0.0008	0.0009	0.0010	0.0012	0.0015	0.0020	0.0025
	125-175	Average	450	0.0004	0.0005	0.0006	0.0008	0.0010	0.0013	0.0018	0.0020	0.0008	0.0009	0.0010	0.0012	0.0015	0.0020	0.0025
	275-325	Average	400	0.0004	0.0005	0.0006	0.0008	0.0010	0.0013	0.0018	0.0020	0.0008	0.0009	0.0010	0.0012	0.0015	0.0020	0.0025
Alloy Steel 4140, 5140, 8640	125-175	Average	575	0.0004	0.0005	0.0006	0.0008	0.0010	0.0013	0.0018	0.0020	0.0008	0.0009	0.0010	0.0012	0.0015	0.0020	0.0025
	175-225	Average	500	0.0004	0.0005	0.0006	0.0008	0.0010	0.0013	0.0018	0.0020	0.0008	0.0009	0.0010	0.0012	0.0015	0.0020	0.0025
	225-275	Average	450	0.0004	0.0005	0.0006	0.0008	0.0010	0.0013	0.0018	0.0020	0.0008	0.0009	0.0010	0.0012	0.0015	0.0020	0.0025
	275-325	Average	400	0.0004	0.0005	0.0006	0.0008	0.0010	0.0013	0.0018	0.0020	0.0008	0.0009	0.0010	0.0012	0.0015	0.0020	0.0025
	325-375	Difficult	375	0.0004	0.0005	0.0006	0.0008	0.0010	0.0013	0.0018	0.0020	0.0008	0.0009	0.0010	0.0012	0.0015	0.0020	0.0025
High Strength Alloy 4340, 4330V, 300M	225-300	Average	450	0.0004	0.0005	0.0006	0.0008	0.0010	0.0013	0.0018	0.0020	0.0008	0.0009	0.0010	0.0012	0.0015	0.0020	0.0025
	300-350	Difficult	400	0.0004	0.0005	0.0006	0.0008	0.0010	0.0013	0.0018	0.0020	0.0008	0.0009	0.0010	0.0012	0.0015	0.0020	0.0025
	350-400	Difficult	350	0.0004	0.0005	0.0006	0.0008	0.0010	0.0013	0.0018	0.0020	0.0008	0.0009	0.0010	0.0012	0.0015	0.0020	0.0025
Structural Steel A36, A285, A516	100-150	Average	600	0.0004	0.0005	0.0007	0.0009	0.0010	0.0015	0.0020	0.0025	0.0008	0.0010	0.0012	0.0015	0.0020	0.0025	0.0030
	150-250	Average	500	0.0004	0.0005	0.0007	0.0009	0.0010	0.0015	0.0020	0.0025	0.0008	0.0010	0.0012	0.0015	0.0020	0.0025	0.0030
	250-350	Difficult	450	0.0004	0.0005	0.0007	0.0009	0.0010	0.0015	0.0020	0.0025	0.0008	0.0010	0.0012	0.0015	0.0020	0.0025	0.0030
High Temperature Alloy Hastealloy B, Inconel 600	140-220	Difficult	120	0.0003	0.0004	0.0006	0.0008	0.0009	0.0010	0.0012	0.0015	0.0005	0.0006	0.0008	0.0010	0.0015	0.0020	0.0025
	220-310	Difficult	90	0.0003	0.0004	0.0006	0.0008	0.0009	0.0010	0.0012	0.0015	0.0005	0.0006	0.0008	0.0010	0.0015	0.0020	0.0025
Stainless Steel 303, 416, 420	135-185	Difficult	250	0.0004	0.0005	0.0006	0.0008	0.0009	0.0010	0.0015	0.0020	0.0005	0.0007	0.0009	0.0015	0.0020	0.0025	0.0030
	185-275	Difficult	200	0.0004	0.0005	0.0006	0.0008	0.0009	0.0010	0.0015	0.0020	0.0005	0.0007	0.0009	0.0015	0.0020	0.0025	0.0030
Stainless Steel PH 17-4	185-275	Difficult	225	0.0004	0.0005	0.0006	0.0008	0.0009	0.0010	0.0015	0.0020	0.0005	0.0007	0.0009	0.0015	0.0020	0.0025	0.0030
	275-325	Difficult	150	0.0004	0.0005	0.0006	0.0008	0.0009	0.0010	0.0015	0.0020	0.0005	0.0007	0.0009	0.0015	0.0020	0.0025	0.0030
Tool Steel H-13, H21, A-4	150-200	Difficult	300	0.0004	0.0005	0.0007	0.0009	0.0010	0.0015	0.0020	0.0025	0.0008	0.0010	0.0012	0.0015	0.0020	0.0025	0.0030
	200-250	Difficult	150	0.0004	0.0005	0.0007	0.0009	0.0010	0.0015	0.0020	0.0025	0.0008	0.0010	0.0012	0.0015	0.0020	0.0025	0.0030
Aluminum , Wrought 6061 T6	30	Easy	1100	0.0005	0.0006	0.0009	0.0010	0.0015	0.0020	0.0025	0.0030	0.0015	0.0020	0.0025	0.0030	0.0040	0.0050	0.0060
	180	Easy	1000	0.0005	0.0006	0.0009	0.0010	0.0015	0.0020	0.0025	0.0030	0.0015	0.0020	0.0025	0.0030	0.0040	0.0050	0.0060
Cast Aluminum - up to 10% Silicon	120	Easy	625	0.0005	0.0006	0.0009	0.0010	0.0015	0.0020	0.0025	0.0030	0.0015	0.0020	0.0025	0.0030	0.0040	0.0050	0.0060
Cast Iron Gray, Ductile, Nodular	120-150	Easy	675	0.0004	0.0005	0.0007	0.0009	0.0010	0.0015	0.0020	0.0025	0.0008	0.0012	0.0015	0.0020	0.0030	0.0040	0.0050
	150-200	Easy	625	0.0004	0.0005	0.0007	0.0009	0.0010	0.0015	0.0020	0.0025	0.0008	0.0012	0.0015	0.0020	0.0030	0.0040	0.0050
	200-220	Easy	575	0.0004	0.0005	0.0007	0.0009	0.0010	0.0015	0.0020	0.0025	0.0008	0.0012	0.0015	0.0020	0.0030	0.0040	0.0050
	220-260	Average	500	0.0004	0.0005	0.0007	0.0009	0.0010	0.0015	0.0020	0.0025	0.0008	0.0012	0.0015	0.0020	0.0030	0.0040	0.0050
	260-320	Average	475	0.0004	0.0005	0.0007	0.0009	0.0010	0.0015	0.0020	0.0025	0.0008	0.0012	0.0015	0.0020	0.0030	0.0040	0.0050
Brass	30-125	Easy	1,100	0.0005	0.0006	0.0009	0.0010	0.0015	0.0020	0.0025	0.0030	0.0020	0.0025	0.0030	0.0040	0.0045	0.0055	0.0065

THREAD MILL PROCESS - INTERNAL THREAD

STEP FUNCTION

- 1 Z rapids in minus direction to depth
- 1~2 rapid in Y-axis to within 0.05 of minor diameter from pos. 1 to 2 and picks up cutter compensation.
- 2~3 feed from pos. 2 to 3 lead in as Z is moved up in the + direction 1/2 thread pitch
- 3~4 feeds 1 revolution from pos. 3 as Z is moved up in the + direction one thread pitch
- 4~5 feeds from pos. 4 to 5 lead out to the center of the hole as Z is moved up in the + direction 1/2 thread pitch all at a higher feed rate
- 5 Z will rapid to the top of the hole and remove cutter compensation

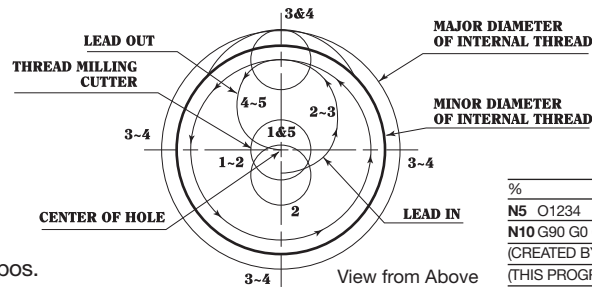

This programming method can be shown in standardized "G" code programming

- The actual cutting of the thread is only three lines of code.
- The feed rate and RPM are calculated using the given surface footage, & chip load as dictated from the chart provided. (1000 SFM & .0015 chip load)
- These starting conditions are then used with the equations provided to determine the programmed feed rate.

$$RPM = \frac{3.82 \times 1000(\text{sfm})}{.745"} = 5128 \text{ RPM}$$

$$F(\text{actual}) = 5128(\text{rpm}) \times .0015(\text{chip load}) \times 4(\# \text{ of flutes}) = 31.1\text{IPM}$$

$$F(\text{programmed}) = \frac{31 \times (1.0 - .745)}{1.0} = 7.9 \text{ IPM}$$

```

%
N5 O1234
N10 G90 G0 G17 G40 D0 G54 G20 G80 G94
(CREATED BY ADVENT THREAD MILLING APPLICATION)
(THIS PROGRAM IS PRODUCED WITH NOMINAL NUMBERS.)
(YOU MUST ADJUST WITH YOUR OFFSET FOR YOUR PERFECT SIZE!)
(TOOL CENTER PROGRAM SET TOOL OFFSET D = 0)
(UN 1-8 RH INNER THREAD IN ALUMINUM)
(TOOL=010834-BH3KL23)
(CUTTING SPEED=1000, CHIPLOAD=0.0015)
(FEED AT CUTTING EDGE=31.0, RPM=5128)
(AT D1.0000 TOOL CENTER FEED = F7.9)
(INCREMENTAL PROGRAM-CLIMB MILLING CODE FOR Fanuc 0M.)
N1 T3
N2 M6
N3 G00 X0.0000 Y0.0000 (delete this line for use as subroutine)
N4 G43 Z0.1000 H36
N5 S5127 M3
N6 G91
N7 Z-1.1625 M8
N8 G1 G41 D3 X0.0000 Y-0.0598 Z0.0000 F46.1
N9 G3 X-0.0000 Y0.1704 Z0.0625 I-0.0000 J0.0852 F7.0
N10 X0.0000 Y0.0000 Z0.1250 I0.0000 J-0.1106 F7.5
N11 X-0.0561 Y-0.0900 Z0.0313 I0.0000 J-0.0625 F40.0
N12 G1 G40 X0.0561 Y-0.0206 Z0.0000
N13 G0 X0.0000 Y0.0000 Z-0.2188
N14 G1 G41 D3 X0.0000 Y-0.0598 Z0.0000 F46.1
N15 G3 X-0.0000 Y0.1873 Z0.0625 I-0.0000 J0.0937 F7.3
N16 X0.0000 Y0.0000 Z0.1250 I0.0000 J-0.1275 F7.9
N17 X-0.0583 Y-0.1141 Z0.0344 I0.0000 J-0.0719 F40.0
N18 G1 G40 X0.0583 Y-0.0134 Z0.0000
N19 G0 G90 Z0.1000 M5
N20 M9
N21 M30
%
    
```

NPT and NPTF

When programming an NPT or NPTF thread form, it may be necessary to program a correction factor to compensate for the tapered thread form. This is achieved by dividing the circular move into quarters or eighths, and moving the cutter out as the arc is generated so that the taper is included in the movement. The amount of the taper for a given form is determined as follows:

$$\text{Taper per pitch} = \frac{.0625"}{\text{pitch (threads per inch)}} \quad \left| \quad \text{e.g. } 0.0044" = \frac{.0625"}{14} / 2 = 0.0022 \text{ RAD}$$

This amount of taper per pitch is a total. Divide it by two which will give you the amount per radian then divide this number by the number of programmed quadrants. This determines the radial amount that the cutter must be moved out as the cutter forms the thread.

```

%
N5 O1234
N10 G90 G0 G17 G40 D0 G54 G70 G80 G94
(CREATED BY ADVENT THREAD MILLING APPLICATION)
(THIS PROGRAM IS PRODUCED WITH NOMINAL NUMBERS)
(YOU MUST ADJUST WITH YOUR OFFSET FOR YOUR PERFECT SIZE)
(TOOL CENTER PROGRAM SET TOOL OFFSET D = 0)
(NPT 1/2-14 RH INNER THREAD IN 303)
(TOOL=121412-1CSNPTH)
(CUTTING SPEED=250, CHIPLOAD=0.0025)
(FEED AT CUTTING EDGE=19.3, RPM=1929)
(AT D0.8179 TOOL CENTER FEED = F7.6)
(Absolute PROGRAM-CLIMB MILLING CODE FOR Fanuc 7M)
N05 T3
N10 G00 X0.0000 Y0.0000
N15 G43 Z0.1000 H3
N20 S1929 M3
N25 Z-0.5700 M8
N30 G1 X-0.0270 F20.0
N35 G41 D3 X-0.1020
N40 G3 X0.1399 Z-0.5343 I0.1209 J0.0000 F6.3
    
```

```

N45 X-0.0004 Y0.1404 Z-0.5164 I-0.1404 J-0.0000 F7.0
N50 X-0.1410 Y-0.0004 Z-0.4986 I0.0004 J-0.1410
N55 X0.0004 Y-0.1416 Z-0.4807 I0.1416 J0.0004
N60 X0.1421 Y0.0004 Z-0.4629 I-0.0004 J0.1421
N65 X-0.1020 Y0.0000 Z-0.4271 I-0.1221 J-0.0004 F40.0
N70 G1 G40 X0.0000
N75 G0 Z-0.5700
N80 G1 X-0.0270 F20.0
N85 G41 D3 X-0.1020
N90 G3 X0.1547 Z-0.5343 I0.1284 J0.0000 F6.6
N95 X-0.0003 Y0.1553 Z-0.5164 I-0.1553 J-0.0000 F7.4
N100 X-0.1559 Y-0.0003 Z-0.4986 I0.0003 J-0.1559 F7.5
N105 X0.0003 Y-0.1564 Z-0.4807 I0.1564 J0.0003
N110 X0.1570 Y0.0003 Z-0.4629 I-0.0003 J0.1570
N115 X-0.1020 Y0.0000 Z-0.4271 I-0.1295 J-0.0003 F40.0
N120 G1 G40 X0.0000
N125 G0 Z0.1000 M5
N130 M9
N135 M30
N140 %
    
```

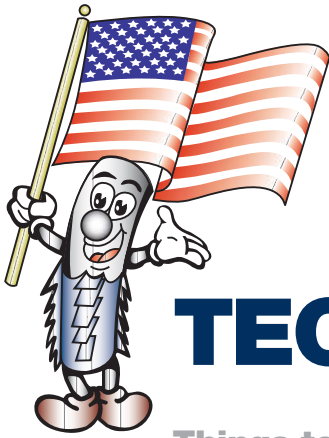

TECHNICAL HELP

Things to Know for **Tool Recommendations and Programming Requests**

- I. Thread Size (Diameter)
- II. Thread Pitch (Threads per Inch)
- III. Length of Thread (Total Thread Depth)
- IV. External (A) or Internal (B) Thread
- V. Material Being Machined
- VI. Type of Machining Center
 - i. Mill or Lathe
 - ii. Horizontal or Vertical
- VII. Type of Tool Holder
 - i. Taper- CAT 40/50, BT 40/50, EM Holder, or Collet, etc.

Things to Know for **Speeds and Feed Programming**

- I. Tool and Insert Part Numbers
- II. Cutter Diameter (D)
- III. Hole Diameter
- IV. Length of Thread (Total Thread Depth)
- V. Material Being Machined
- VI. Movement- Absolute or Incremental

*For Special Forms contact Info@advent-threadmill.com
or Sales@advent-threadmill.com*

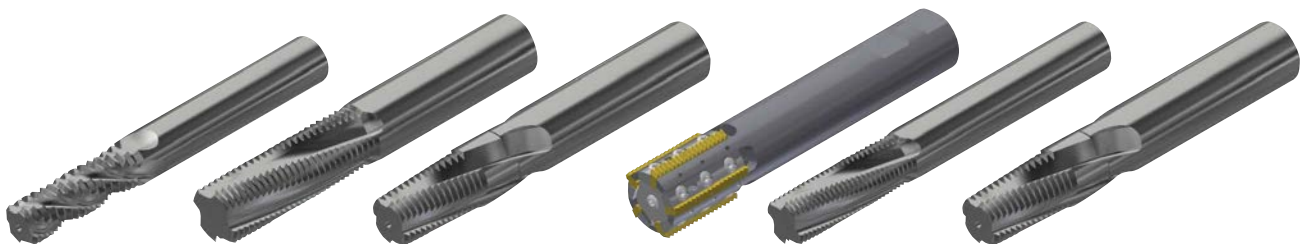

FIND THE CORRECT INSERT HOLDER FOR YOUR APPLICATION

I. KNOW YOUR THREAD...

- a. Too large of a cutter diameter relative to the Minor \varnothing (d) of your threaded hole will have adverse effects on every aspect of your threadmilling operation(s).

For example, a #125-TA-78-F3 tool loaded with 12 pitch inserts has a cutter diameter of 0.970". The same tool loaded with an 8 pitch or (a tapered thread-form insert) has a cutter diameter of 1.100"; in cases like this, with your minor diameter in mind, you may opt to choose a smaller diameter Tool Holder.

- b. Minor \varnothing (d) - .020" = Max Tool \varnothing (Holder w/ Inserts)

II. FIND INSERT SIZE...

- a. If the *Max Tool \varnothing is **less than** .970" use a 38A or 38B Insert
 - I. Use Thread Depth to pick a set length of insert needed
 - II. Length of 38A is 1" and 38B is 1.5"
- b. If the *Max Tool \varnothing is **more than** .970" use a 410A Insert.
 - I. Length of 410A is 1.5"

** Cutter Diameters for specialized forms such as ACME and Stub ACME should be checked with our technical department.

III. CHOOSE YOUR INSERT...

- a. Using the insert size determined above in "II" (38A/B or 410A) along with the known thread pitch for your application, the Insert Part Number is determined.
- b. Locate the Insert Part Number, in the catalog. Note the **Insert Height- Measurement "C"** for use in determining actual Tool Holder Cutter \varnothing .

IV. SELECT TOOL HOLDER...

- a. Reference the Insert Height to Measurement "C", in Insert Section, to determine the Cutter \varnothing .
- b. With respect to Max Tool \varnothing from "I" determine preferred tool holder, so that Cutter \varnothing is no larger than Max Tool \varnothing .

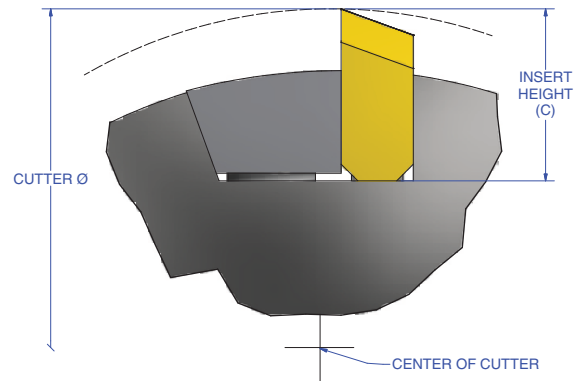
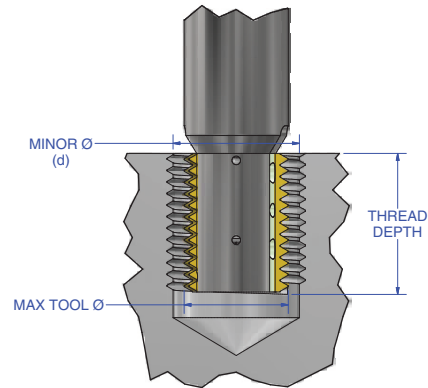

PROPER INSERT INSTALLATION IN TOOL HOLDER POCKET

ORDER OF INSTALLATION...

1. Locating disc & screw
2. Insert & wedge (without screws)
3. Middle wedge screw - while drawing insert back against locating disc
4. Outside wedge screws - tighten gradually, alternating front to back until fully tightened

Procedure for installation with locating pin is the same as with a locating disc.

The insert should be pressed down into the pocket and back against the locating disc as shown

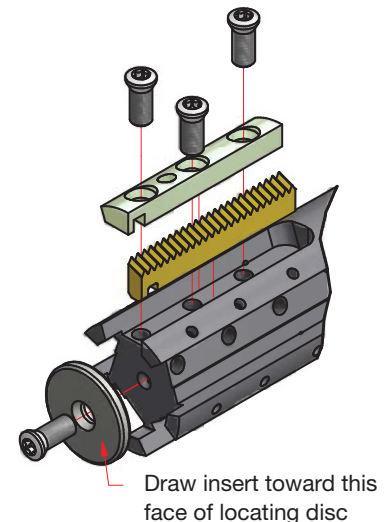
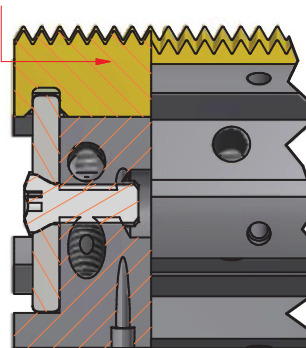

REPLACEABLE INSERT THREAD MILL DESIGNATION



Column 1: "-" = Standard Tool Style

HP = High Pressure Tool Style - New design to optimize high pressure coolant by placing coolant exit holes directly in front of the inserts.

Column 2: Thread Milling Tool Size

78 = 0.875"

01 = 1.0"

125 = 1.250"

138 = 1.375"

15 = 1.5"

175 = 1.75"

20 = 2.0"

30 = 3.0"

35 = 3.5"

40 = 4.0"

50 = 5.0"

60 = 6.0"

Column 3: Tool Body

TA = Tool Assembly

Column 4: Tool Shank Size

05 = Shank \varnothing 0.500"

34 = Shank \varnothing 0.750"

78 = Shank \varnothing 0.875"

01 = Shank \varnothing 1.000"

125 = Shank \varnothing 1.250"

150 = Shank \varnothing 1.500"

200 = Shank \varnothing 2.000"

Column 5: Number of Flutes

F2 = 2 Flutes

F3 = 3 Flutes

F4 = 4 Flutes

F5 = 5 Flutes

F6 = 6 Flutes

F8 = 8 Flutes

F10 = 10 Flutes

F12 = 12 Flutes

F14 = 14 Flutes

F16 = 16 Flutes

F20 = 20 Flutes

F24 = 24 Flutes

Column 6: Tool Length:

Over All Length (OAL)

(Extended Length Tools only)

9 = 9" OAL - Extended Length

6 = 6" OAL - Extended Length

Column 7: Weldon Flat

"-" = Weldon Flat

"X" = No Weldon Flat

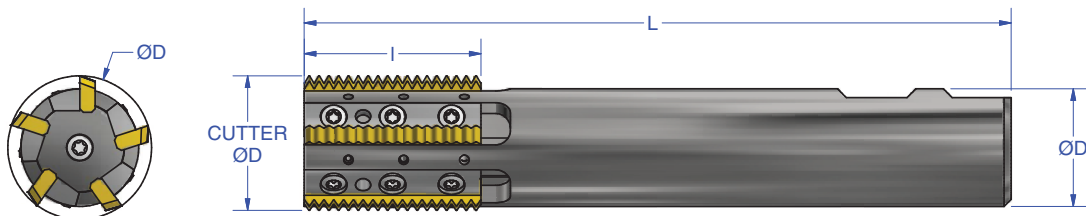

REPLACEABLE INSERT THREAD MILLS STANDARD SIZE - MULTI-FLUTE

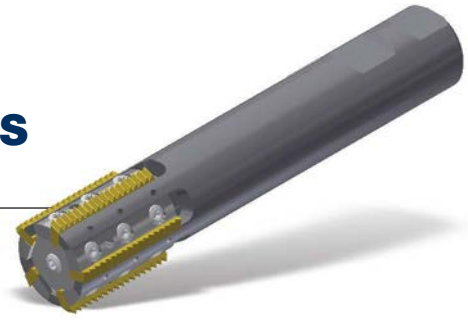

- Through Coolant
- Hardened and CNC Ground
- Standard Weldon Shanks
- Additional Options
- High Pressure (HP)
- Shank Without Weldon
- "X" at the end of part number. Check for availability

**For Large Pitch internal applications DOUBLE CHECK
Tool Cutter Diameter and Minor Diameter for proper clearance.**

Dimensions in Inches (mm)

Part Number	Cutter Diameter (d)			Insert Size	Length of Cut (l)	Number of Flutes	Tool Length (L)	Shank Diameter (D)		
	.250	38A & 38B Insert Heights .310	.310							
12-TA-34NPT*	N/A	.690 (17.53)	N/A	38A	1.0 (25)	1	4.0 (102)	0.750		
34-TA-34	.625 (15.88)	.745 (18.92)	N/A	38A	1.0 (25)	1	4.0 (102)	0.750		
78-TA-34	.750 (19.05)	.870 (22.10)	N/A	38B	1.5 (38)	1	4.5 (114)	0.750		
78-TA-05-F2	.700 (17.78)	.820 (20.83)	N/A	38A	1.0 (25)	2	4.0 (102)	0.500		
01-TA-34-F2	.750 (19.05)	.870 (22.10)	N/A	38A	1.0 (25)	2	4.0 (102)	0.750		
01-TA-34-F2-6							6.0 (152)			
01-TA-78-F3	.844 (21.244)	.964 (24.49)	N/A	38B	1.5 (38)	3	4.0 (102)	0.875		
01-TA-78-F3-6							6.0 (152)			
01-TA-78-F3-9							9.0 (229)			
01-TA-01	.844 (21.244)	.964 (24.49)	N/A	38B	1.5 (38)	1	4.0 (102)	1.000		
01-TA-01-F3							3		4.0 (102)	
01-TA-01-F3-6										6.0 (152)
01-TA-01-F3-9										
410A Insert Heights										
	.310	.375	.408							
125-TA-78-F3	.970 (24.64)	1.100 (27.94)	1.166 (29.62)	410A	1.5 (38)	3	4.25 (108)	0.875		
125-TA-78-F3-6							6.0 (152)			
125-TA-78-F3-9							9.0 (229)			
125-TA-01	.970 (24.64)	1.100 (27.94)	1.166 (29.62)	410A	1.5 (38)	1	4.25 (108)	1.000		
125-TA-01-F3							3		4.25 (108)	
125-TA-01-F3-6										6.0 (152)
125-TA-01-F3-9	9.0 (229)									
138-TA-01-F4	1.180 (29.97)	1.310 (33.27)	1.376 (34.95)	410A	1.5 (38)	4	4.5 (114)	1.000		
138-TA-125-F4-7							4		7.0 (178)	
138-TA-125-F4-9	9.0 (229)									
15-TA-01-F5	1.220 (30.99)	1.350 (34.29)	1.416 (35.97)	410A	1.5 (38)	5	6.0 (152)			
15-TA-01-F5-6							9.0 (229)			
15-TA-01-F5-9										
175-TA-125-F5	1.470 (37.34)	1.600 (40.64)	1.666 (42.32)	410A	1.5 (38)	5	4.5 (114)	1.250		
175-TA-125-F5-6							6.0 (152)			
175-TA-125-F5-9									9.0 (229)	
20-TA-125-F6	1.720 (43.69)	1.850 (46.99)	1.916 (48.87)	410A	1.5 (38)	6	5.0 (127)	1.250		
20-TA-125-F6-6							6.0 (152)			
20-TA-125-F6-9									9.0 (229)	
25-TA-125-F8	2.120 (53.85)	2.250 (57.15)	2.316 (58.83)	410A	1.5 (38)	8	5.0 (127)	1.250		
25-TA-125-F8-9							9.0 (229)			
30-TA-150-F12	2.620 (66.55)	2.750 (69.85)	2.816 (71.53)	410A	1.5 (38)	12	6.0 (152)	1.500		
30-TA-150-F12-9							9.0 (229)			
35-TA-150-F14	3.120 (79.25)	3.250 (82.55)	3.316 (84.23)	410A	1.5 (38)	14	6.0 (152)	1.500		
35-TA-150-F14-9							9.0 (229)			
40-TA-200-F16	3.620 (91.95)	3.750 (95.25)	3.816 (96.93)	410A	1.5 (38)	16	7.0 (178)	2.000		
40-TA-200-F16-12							12.0 (305)			
50-TA-200-F20	4.620 (117.35)	4.750 (120.65)	4.816 (122.33)	410A	1.5 (38)	20	9.0 (229)	2.000		
50-TA-200-F20-12							12.0 (305)			
60-TA-200-F24	5.595 (142.11)	5.725 (145.42)	5.791 (147.09)	410A	1.5 (38)	24	11.0 (279)	2.000		

* For NPT/BSPT use only - For NPT/BSPT 38A & 38B use Insert Height .310 - For NPT/BSPT 410A use Insert Height .375

REPLACEABLE INSERT THREAD MILLS METRIC SIZE - MULTI-FLUTE

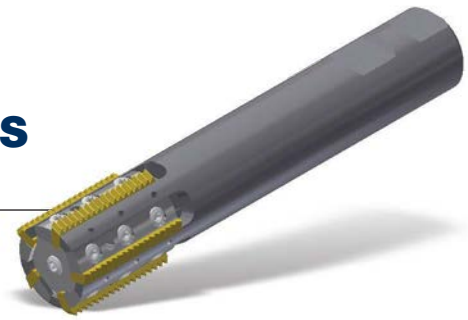

- Through Coolant
- Hardened and CNC Ground
- Standard Weldon Shanks
- Additional Options
- High Pressure (HP)
- Shank Without Weldon
- "X" in the end of part number. Check for availability

**For Large Pitch internal applications DOUBLE CHECK
Tool Cutter Diameter and Minor Diameter for proper clearance.**

Dimensions in Inches (mm)

Part Number	Cutter Diameter (d)			Insert Size	Length of Cut (l)	Number of Flutes	Tool Length (L)	Shank Diameter (D)		
	.250	38A & 38B Insert Heights .310								
12-TA-20MMNPT*	N/A	.690 (17.53)		38A	1.0 (25)	1	4.0 (102)	(20)		
EM20-TA-20	.625 (15.88)	.750 (19.05)				1				
EM22-TA-12-F2	.700 (17.78)	.820 (20.83)				2		(12)		
EM24-TA-20	.750 (19.050)	.870 (20.83)		38B	1.5 (38)	1	4.5 (114)	(20)		
EM24-TA-20-F2				38A	1.0 (25)	2	4.0 (102)	(20)		
EM24-TA-20-F2-6							2	6.0 (152)	(20)	
EM27-TA-25	844 (21.44)	.964 (24.49)		38B	1.5 (38)	1	4.5 (114)	(25)		
EM27-TA-20-F3.						3	4.0 (102)	(20)		
EM27-TA-20-F3-9							3	9.0 (209)	(20)	
	410A Insert Heights									
	.310	.375	.408							
EM33-TA-25	.970 (24.64)	1.100 (27.94)	1.166 (29.62)	410A	1.5 (38)	1	4.5 (114)	(25)		
EM33-TA-20-F3						3	4.25 (108)	(20)		
EM33-TA-20-F3-9							3	9.0 (229)	(20)	
EM35-TA-25-F4	1.180 (29.97)	1.310 (33.27)	1.376 (34.95)	410A	1.5 (38)	4	4.5 (114)	(25)		
EM35-TA-25-F4-7								4	7.0 (178)	
EM35-TA-25-F4-9								4	9.0 (229)	
EM39-TA-25-F5	1.220 (30.99)	1.350 (34.29)	1.416 (35.97)	410A	1.5 (38)	5	4.5 (114)	(25)		
EM39-TA-25-F5-9								5	9.0 (229)	
EM45-TA-32-F5	1.470 (37.34)	1.600 (40.64)	1.666 (42.32)	410A	1.5 (38)	5	4.5 (114)	(32)		
EM45-TA-32-F5-9								5	9.0 (229)	
EM52-TA-32-F6	1.720 (43.69)	1.850 (46.99)	1.916 (48.87)	410A	1.5 (38)	6	5.0 (127)	(32)		
EM52-TA-32-F6-9								6	9.0 (229)	
EM64-TA-32-F8	2.120 (53.85)	2.250 (57.15)	2.316 (58.83)	410A	1.5 (38)	8	5.0 (127)	(32)		
EM64-TA-32-F8-9								8	9.0 (229)	
EM76-TA-40-F12	2.620 (66.55)	2.750 (69.85)	2.816 (71.53)	410A	1.5 (38)	12	6.0 (152)	(40)		
EM76-TA-40-F12-9								12	9.0 (229)	
EM90-TA-40-F14	3.120 (79.25)	3.250 (82.55)	3.316 (84.23)	410A	1.5 (38)	14	6.0 (152)	(40)		
EM90-TA40-F14-9								14	9.0 (229)	
EM105-TA-50-F16	3.620 (91.95)	3.750 (95.25)	3.816 (96.93)	410A	1.5 (38)	16	7.0 (178)	(50)		
EM105-TA-50-F16-12								16	12.0 (305)	
EM130-TA-50-F20	4.620 (117.35)	4.750 (120.65)	4.816 (122.33)	410A	1.5 (38)	20	9.0 (229)	(50)		
EM130-TA-50-F20-12								20	12.0 (305)	
EM160-TA-50-F24	5.595 (142.11)	5.725 (145.42)	5.791 (147.09)	410A	1.5 (38)	24	11.0 (279)	(50)		

* For NPT/BSPT use only.
For NPT/BSPT 38A & 38B use Insert Height .310
For NPT/BSPT 410A use Insert Height .375

REPLACEABLE INSERT THREAD MILLS HIGH PRESSURE VERSION



- Through Coolant
 - Hardened and CNC Ground
 - Standard Weldon Shanks
 - Additional Options
 - Shank without Weldon
- "X" in the end of part number. Check for availability

**For Large Pitch internal applications DOUBLE CHECK
Tool Cutter Diameter and Minor Diameter for proper clearance.**

Dimensions in Inches (mm)

Part Number	Cutter Diameter (d)			Insert Size	Length of Cut (l)	Number of Flutes	Tool Length (L)	Shank Diameter (D)
	38A & 38B Insert Heights							
	.250	.310						
HP01-TA-34-F2 HP01-TA-34-F2-6	.750 (19.05)	.870 (22.10)		38A	1.0 (25)	2	4.0 (102) 6.0 (152)	.750
HP01-TA-78-F3 HP01-TA-78-F3-9	.844 (21.44)	.964 (24.49)		38B	1.5 (38)	3	4.0 (102) 9.0 (229)	.875
	410A Insert Heights							
	.310	.375	.408					
HP125-TA-78-F3 HP125-TA-78-F3-9	.970 (24.64)	1.100 (27.94)	1.166 (29.62)	410A	1.5 (38)	3	4.25 (108) 9.0 (229)	.875
HP138-TA-01-F4 HP138-TA-125-F4-7 HP138-TA-125-F4-9	1.180 (29.97)	1.310 (33.27)	1.376 (34.95)	410A	1.5 (38)	4	4.5 (114) 7.0 (178) 9.0 (229)	1.000 1.250
HP15-TA-01-F5 HP15-TA-01-F5-9	1.220 (30.99)	1.350 (34.29)	1.416 (35.97)	410A	1.5 (38)	5	4.5 (114) 9.0 (229)	1.000
HP175-TA-125-F5 HP175-TA-125-F5-9	1.470 (37.34)	1.600 (40.64)	1.666 (42.32)	410A	1.5 (38)	5	4.5 (114) 9.0 (229)	1.250
HP20-TA-125-F6 HP20-TA-125-F6-9	1.720 (43.69)	1.850 (46.99)	1.916 (48.87)	410A	1.5 (38)	6	5.0 (127) 9.0 (229)	1.250
HP25-TA-125-F8 HP25-TA-125-F8-9	2.120 (53.85)	2.250 (57.15)	2.316 (58.83)	410A	1.5 (38)	8	5.0 (127) 9.0 (229)	1.250
HP30-TA-150-F12 HP30-TA-150-F12-9	2.620 (66.55)	2.750 (69.85)	2.816 (71.53)	410A	1.5 (38)	12	6.0 (152) 9.0 (229)	1.500
HP35-TA-150-F14 HP35-TA-150-F14-9	3.120 (79.25)	3.250 (82.55)	3.316 (84.23)	410A	1.5 (38)	14	6.0 (152) 9.0 (229)	1.500
HP40-TA-200-F16 HP40-TA-200-F16-12	3.620 (91.95)	3.750 (95.25)	3.816 (96.93)	410A	1.5 (38)	16	7.0 (178) 12.0 (305)	2.000
HP50-TA-200-F20 HP50-TA-200-F20-12	4.620 (117.35)	4.750 (120.65)	4.816 (122.33)	410A	1.5 (38)	20	9.0 (229) 12.0 (305)	2.000
HP60-TA-200-F24	5.595 (142.11)	5.725 (145.42)	5.791 (147.09)	410A	1.5 (38)	24	11.0 (279)	2.000

INTEGRAL SHANK REPLACEABLE INSERT THREAD MILLS



- Standard V-flange Tool Shank (ANSI/ASME B5.50-1985)
- 1.5" Length of Cut
- Through Coolant
- Hardened and CNC Ground
- Use ATM-410A Insert Size

For Large Pitch internal applications DOUBLE CHECK Tool Cutter Diameter and Minor Diameter for proper clearance.

CV-50 THREAD MILLS

Dimensions in Inches (mm)

Part Number	Cutter Diameter (d)			Number of Flutes	Length From Gauge Line (L)	Useable Cutter Length
	.310	410A Insert Heights .375	.408			
C125TAC50-F3-4	.970 (24.64)	1.100 (27.94)	1.166 (29.62)	3	4 (102)	3.0 (76)
C125TAC50-F3-5						3.5 (89)
C138TAC50-F4-4	1.180 (29.97)	1.310 (33.27)	1.376 (34.95)	4	4 (102)	3.0 (76)
C138TAC50-F4-5						3.5 (89)
C138TAC50-F4-6						4.5 (114)
C15TAC50-F5-4	1.220 (30.99)	1.350 (34.29)	1.416 (35.97)	5	4 (102)	3.0 (76)
C15TAC50-F5-5						3.5 (89)
C15TAC50-F5-6						4.5 (114)
C175TAC50-F5-4	1.470 (37.34)	1.600 (40.64)	1.666 (42.32)	5	4 (102)	3.0 (76)
C175TAC50-F5-5						3.5 (89)
C175TAC50-F5-6						4.5 (114)
C175TAC50-F5-7						5.5 (140)
C20TAC50-F6-4	1.720 (43.69)	1.850 (46.99)	1.916 (48.87)	6	4 (102)	3.0 (76)
C20TAC50-F6-5						3.5 (89)
C20TAC50-F6-6						4.5 (114)
C20TAC50-F6-7						5.5 (140)
C20TAC50-F6-8						6.5 (165)
C25TAC50-F8-6	2.120 (53.85)	2.250 (57.15)	2.316 (58.83)	8	6 (152)	4.5 (114)
C25TAC50-F8-8						6.5 (165)
C25TAC50-F8-10						8.5 (216)
C30TAC50-F12-6	2.620 (66.55)	2.750 (69.85)	2.816 (71.53)	12	6 (152)	4.5 (114)
C30TAC50-F12-8						6.5 (165)
C30TAC50-F12-10						8.5 (216)
C35TAC50-F14-6	3.120 (79.25)	3.250 (82.55)	3.316 (84.23)	14	6 (152)	5.25 (133)
C35TAC50-F14-8						7.25 (184)
C35TAC50-F14-10						9.25 (235)
C40TAC50-F16-6	3.620 (91.95)	3.750 (95.25)	3.816 (96.93)	16	6 (152)	5.25 (133)
C40TAC50-F16-8						7.25 (184)
C40TAC50-F16-10						9.25 (235)

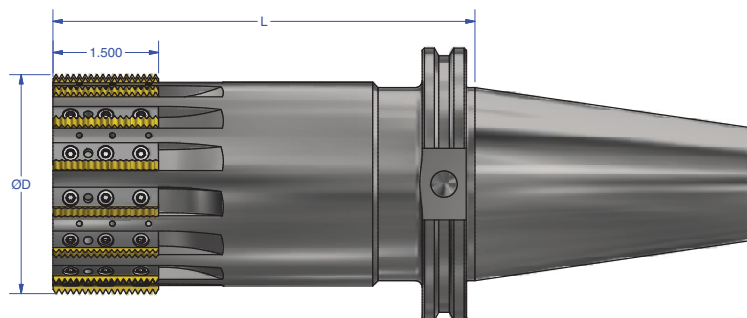

SHELL MILL REPLACEABLE INSERT THREAD MILLS



- 1.0" Length of Cut (LOC) - 38A Insert Size
- 1.5" Length of Cut (LOC)- 410A Insert Size
- 1.25"-2.0" Overall Length (OAL)
- Use ATM-38A and ATM-410A Inserts
- Fits Standard Shell Mill Adaptors

For Large Pitch internal applications DOUBLE CHECK Tool Cutter Diameter and Minor Diameter for proper clearance.

Dimensions in Inches (mm)

Part Number	Cutter Diameter (d)			Insert Size	Face Diameter	Number of Flutes	Hole Diameter (D)	Slot Width
	.250	38A Insert Size .310						
SM20TA3-F8	1.750 (44.45)	1.870 (47.50)		38A	1.250	8	0.500	0.250
SM23TA3-F12	2.000 (50.80)	2.120 (53.85)		38A	1.490	12	0.750	0.312
	410A Insert Size							
	.310	.375	.408					
SM25TA-F8 SMEM64TA-F8	2.120 (53.85)	2.250 (57.15)	2.316 (58.83)	410A	1.900	8	0.750 (16)	0.312 (8)
SM30TA-F12 SMEM76TA-F12	2.620 (66.55)	2.750 (69.85)	2.816 (71.53)	410A	2.000	12	0.750 (22)	0.312 (10)
SM35TA-F14 SMEM90TA-F14	3.120 (79.25)	3.250 (82.55)	3.316 (84.23)	410A	2.375	14	1.000 (27)	0.375 (12)
SM40TA-F16 SMEM105TA-F16	3.620 (91.95)	3.750 (95.25)	3.816 (96.93)	410A	2.375	16	1.000 (27)	0.375 (12)
SM50TA-F20	4.620 (117.35)	4.750 (120.65)	4.816 (122.33)	410A	3.750	20	1.500	0.625
SM60TA-F24	5.595 (142.11)	5.725 (145.42)	5.791 (147.09)	410A	4.500	24	2.000	0.750

* Concentricity of cutters is subject to quality of tool holder used.

* For non-coolant thru applications specify "LDH" locating discs with thru hole.

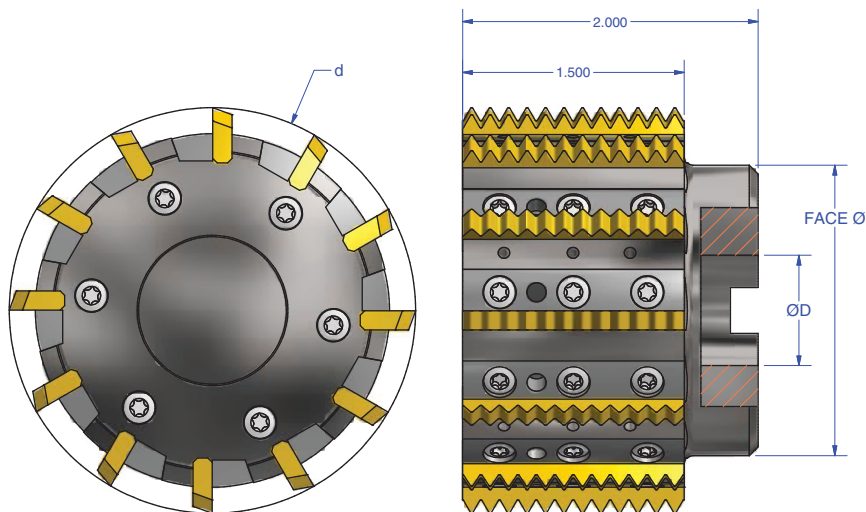

LATHE TOOLING

- Can be used on Manual and VTLs w/Milling Capabilities
- Shank Tools and Shell Mills can be used for Internal and External threadmilling
- Full-Threading within half a pitch from the bottom of the thread
- No Bird's Nesting during threadmilling procedure
- Burr-Free Threading
- Perfect Thread Orientation
- The ability to cut NPT threads up to a shoulder
- Right and Left Hand Capability
- Lay Down Holders are ideal for cutting serrations
- Longer Insert Life

SHANKS TOOLS

Dimensions in Inches

Tool Number	Cutter Diameter		Length of Cut (l)	Tool Length (OAL)	Number of Flutes	Shank Diameter (D)
	38A Insert Size .250	.310				
S135TA34-F5	1.350	1.470	1.000	3.500	5	0.750
S135TA34-F6	(34.29)	(37.34)			6	
S135TA34-F8					8	

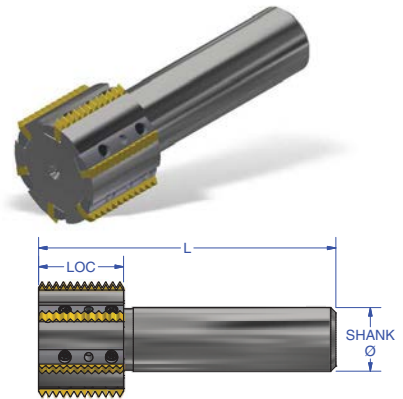

SHELL MILLS

Tool Number	Cutter Diameter		Face Diameter	Length of Cut (l)	Tool Length (OAL)	Number of Flutes	Hole Diameter (D)	Slot Width (Key Way)
	38A Insert Size .250	.310						
SM20TA3-F8	1.750 (44.45)	1.870 (47.50)	1.250	1.000	1.250	8	0.500	0.250
SM23TA3-F12	2.000 (50.80)	2.120 (53.85)	1.490	1.000	1.500	12	0.750	0.312

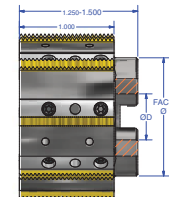

SHELL MILL ADAPTORS

Tool Number	Boss Diameter (D)	Face Diameter	Shank Diameter (D)
SMA34/0.50	0.500	1.750	0.750
SMA34/0.75	0.750	1.900	
SMA34/1.00	1.000	2.000	

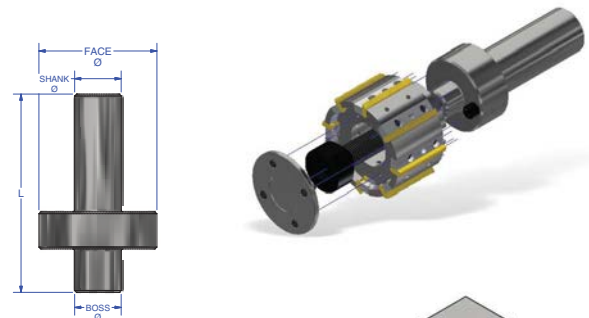

LAY-DOWN INSERT HOLDER

Tool Number	Cutter Diameter			Length of Cut (LOC)	Tool Length (L)	Shank Size (SS)	Shank Length (SL)
	410A & 412A Insert Size .250	.310	.408				
ATM-0106TH-L	5.935	6.000	6.033	1.500	5.825	1.000	4.100
ATM-0106TH-R	(150.75)	(152.40)	(153.24)				
ATM-17506TH-L				2.000		1.750	

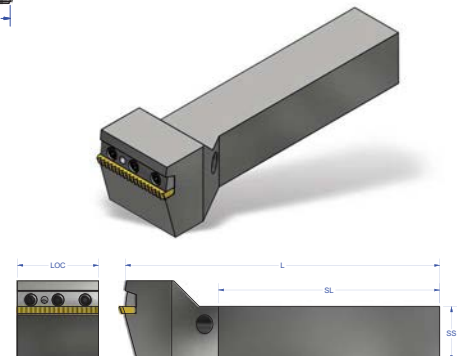

GT INDEXABLE TOOLING (GENERATION TWO) WITH DOUBLE SIDED INSERTS FOR UNC THREADS

- Fully Hardened / CNC Ground
- Thru Body Coolant
- Indexable Double Sided Inserts
- Can Be Run Without End Plate For Blind Holes
- Small Diameter / Corse Pitch Internal Threading Applications

1"-8UN, 1 1/8"-7UN, 1 1/4"-7UN, & 1 3/8"-6UN - 1.5" & 1.75" DEEP

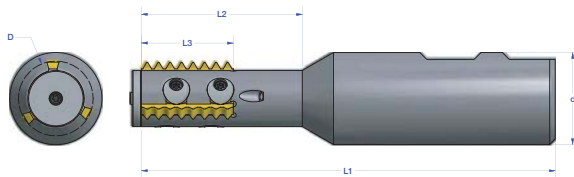

GTS01-TA-01-F3R175

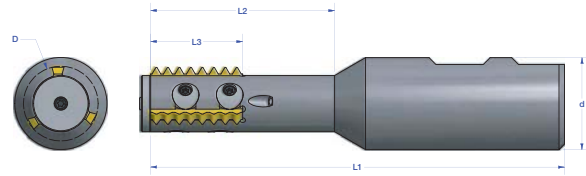

GTS01-TA-01-F3R20

TOOL ASSEMBLY				
Part Number	Description	Length (L1)	Relief (L2)	Shank (d)
GTS01-TA-01-F3R175	3 Flute Dbl. Side Ins. Mill	4.5"	1.75"	1.0"
GTS01-TA-01-F3R20	3 Flute Dbl. Side Ins. Mill	4.5"	2.0"	1.0"

REPLACEABLE PART NUMBERS	
Wedges (2)	Description
ATM-W464R031	Wedge for GTS01-TA-01-F3R__
End Cap (3)	Description
ATM-GTS01EP	End Cap for GTS01-TA-01-F3R__
Screws (4)	Description
PT464-8IP	M2.5 X 0.45-6H,8IP TORXPLUS

DOUBLE SIDED INSERTS (1)		COATINGS		
Part Number	Length (L3)	Cut Diameter (D)	Z	V
SATM-510D8B	1.0"	0.810	O	X
SATM-510D7B	1.0"	0.840	O	X
SATM-510D6B	1.0"	0.870	O	X

X = In Stock, O = Available by Request. See Page 17 for Coatings

1 1/4"-7UN & 1 3/8"-6UN - 3.0" DEEP

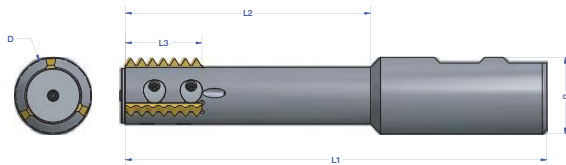

GTS125-TA-01-F3R32

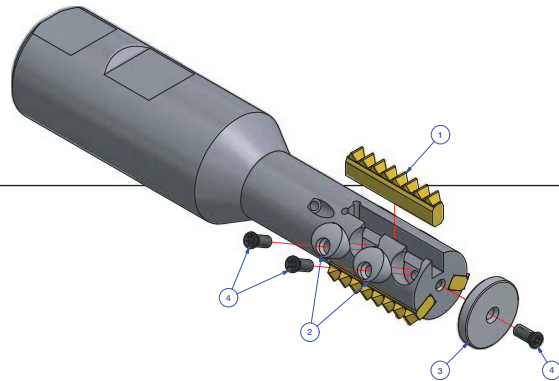

TOOL ASSEMBLY				
Part Number	Description	Length (L1)	Relief (L2)	Shank (d)
GTS125-TA-01-F3R32	3 Flute Dbl. Side Ins. Mill	5.5"	3.2"	1.0"

REPLACEABLE PART NUMBERS	
Wedges (2)	Description
ATM-W464R037	Wedge for GTS125-TA-01-F3R32
End Cap (3)	Description
ATM-GTS125EP	End Cap for GTS125-TA-01-F3R32
Screws (4)	Description
PT464-8IP	M2.5 X 0.45-6H,8IP TORXPLUS

DOUBLE SIDED INSERTS (1)		COATINGS		
Part Number	Length (L3)	Cut Diameter (D)	Z	V
SATM-510D7B	1.0"	0.980	O	X
SATM-510D6B	1.0"	1.010	O	X

X = In Stock, O = Available by Request. See Page 17 for Coatings

FACE GROOVING TOOLS

- Tools used for grooving pipe flange surfaces for gasket seals
- Custom forms available, contact us with your requirements
- Fits Standard Shell Mill and Face Mill Adaptors

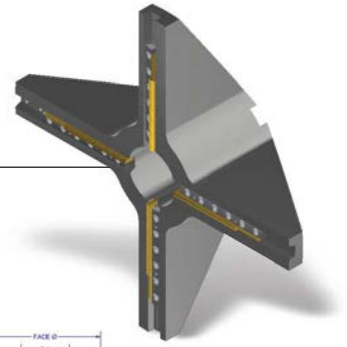

410A, 412A STYLE INSERTED TOOL

- Any standard 410A or 412A insert (cannot stack)
- Special controlled length (1.5" & 2.0) inserts can be stacked the length of pocket to cover different cut ranges

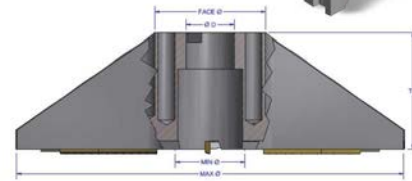

Dimensions in Inches

Tool Number	Face Diameter	Covered Diameter		Insert Style	Tool Height/ Thickness (TH)	Hole Diameter (D)	Slot Width	Number of Flutes
		Min.	Max.					
SM-SER-10X4	2.875	1.800	9.800	410A 412A	3.000	1.250	0.500	4
SM-SER-14X4	5.200	2.200	14.200	410A 412A	3.000	2.000	0.750	4
SM-SER-22X2	5.000	6.200	22.200	412A	3.000	2.000	0.750	2

Insert Number	Pitch	Form	Measurements			Coatings Available		
			A	B	C	C TiN	Z TiAlN	V AlTiN
SATM-410A48L15	48	60° Flank Angle	1.500	0.130	0.310	O	X	O
SATM-410A48L20	48	60° Flank Angle	2.000	0.130	0.310	O	X	O
SATM-410A50R018L15	50	0.018" Radius	1.500	0.130	0.310	O	X	O
SATM-412A50R018L20	50	0.018" Radius	2.000	0.130	0.310	O	X	O
SATM-410A36R034L15	36	0.034" Radius	1.500	0.130	0.310	O	X	O
SATM-412A36R034L20	36	0.034" Radius	2.000	0.130	0.310	O	X	O

X = In Stock ; O = Special Order

610A, 627A, 630A STYLE INSERTED TOOL

- Locating pins are staggered 0.020" for 50 Pitch (others available)
- Special controlled length (2.0" - 4.0") inserts can be stacked the length of pocket to cover different cut ranges

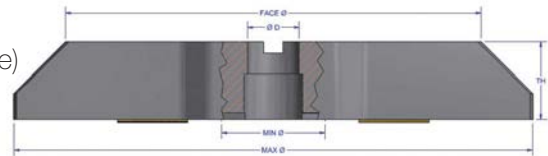

Tool Number	Face Diameter	Covered Diameter		Insert Style	Tool Height/ Thickness (TH)	Hole Diameter (D)	Slot Width	Number of Flutes
		Min.	Max.					
SM-SER6AS-20X2	5.000	8.800	20.000	ATM-6...A	3.000	2.000	0.750	2

Insert Number	Pitch	Form	Measurements			Coatings Available		
			A	B	C	C TiN	Z TiAlN	V AlTiN
SATM-627A25R13	25	Staggered 50 Pitch; 0.013" Radius	2.700	0.188	0.375	O	X	O
SATM-627A48L27	48	60° Flank Angle	2.700	0.188	0.375	O	X	O
SATM-630A50R018L30	50	0.018" Radius	3.000	0.188	0.375	O	X	O

X = In Stock ; O = Special Order

REPLACEABLE INSERT MILLS: REPLACEABLE PARTS



All screws used on Replaceable Insert Mills are Torx Plus Screws.

Standard Shank (U.S.) Replaceable Insert Thread Mill Replacement Parts

Tool Number (1)	Locating Disc (2)	Locating Disc Screws (5)	Wedge (3)	Wedge Screws (4)
78-TA-05-F2	ATM-PIN01F1	N/A	ATM-38AWN	PT464-8IP
01-TA-34-F2				
34-TA-34				
14-TA-12NPT				
12-TA-34NPT				
78-TA-34				
01-TA-78-F3			ATM-38BWN	
01-TA-01				
125-TA-01				
125-TA-78-F3				
138-TA-01-F4				
15-TA-01-F5	ATM-125LD	PT464-8IP	ATM-410WS	PT483S-15IP
175-TA-125-F5	ATM-138LD			
20-TA-125-F6	ATM-150LD			
25-TA-125-F8	ATM-175LD			
30-TA-150-F12	ATM-200LD			
35-TA-150-F14	ATM-250LD	PT483T-15IP	ATM-410WL	PT483T-15IP
40-TA-200-F16	ATM-300LD			
50-TA-200-F20	ATM-350LD			
60-TA-200-F24	ATM-400LD			
	ATM-600LD			

CV-50 Thread Mills Replacement Parts

Tool Number (1)	Locating Disc (2)	Locating Disc Screws (5)	Wedge (3)	Wedge Screws (4)	
C125TAC50-F3	ATM-125LD	PT464-8IP	ATM-410WS	PT483S-15IP	
C138TAC50-F4	ATM-138LD	PT483T-15IP		ATM-410WL	PT483T-15IP
C15TAC50-F5	ATM-150LD				
C175TAC50-F5	ATM-175LD				
C20TAC50-F6	ATM-200LD				
C25TAC50-F8	ATM-250LD				
C30TAC50-F12	ATM-300LD	PT483T-15IP	ATM-410WL	PT483T-15IP	
C35TAC50-F14	ATM-350LD				
C40TAC50-F16	ATM-400LD				
	ATM-600LD				

Replaceable Insert Thread Mills High Pressure Version Replacement Parts

Tool Number (1)	Locating Disc (2)	Locating Disc Screws (5)	Wedge (3)	Wedge Screws (4)
HP01-TA-34-F2	ATM-PIN01F1	N/A	ATM-38AW/HP	PT464-8IP
HP01-TA-78-F3			ATM-38BW/HP	
HP125-TA-78-F3	ATM-125LD	PT464-8IP	ATM-410WS/HP	PT483S-15IP
HP138-TA-125-F4	ATM-138LD	PT483T-15IP		
HP15-TA-01-F5	ATM-150LD			
HP175-TA-125-F5	ATM-175LD			
HP20-TA-125-F6	ATM-200LD			
HP25-TA-125-F8	ATM-250LD		PT483T-15IP	ATM-410WL/HP
HP30-TA-150-F12	ATM-300LD			
HP35-TA-150-F14	ATM-350LD			
HP40-TA-200-F16	ATM-400LD			
HP50-TA-200-F20	ATM-500LD			
HP60-TA-200-F24	ATM-600LD			

Metric Shank Replaceable Insert Thread Mills Replacement Parts

Tool Number (1)	Locating Disc (2)	Locating Disc Screws (5)	Wedge (3)	Wedge Screws (4)	
EM20-TA-20	ATM-PIN01F1	N/A	ATM-38AWN	PT464-8IP	
EM22-TA-12-F2					
EM24-TA-20-F2			ATM-38BWN		
EM24-TA-20					
EM27-TA-25			PT464-8IP		ATM-410WS
EM27-TA-20-F3					
EM33-TA-25	PT483T-15IP	PT483T-15IP	ATM-410WL	PT483T-15IP	
EM33-TA-20-F3					ATM-125LD
EM35-TA-25-F4					ATM-138LD
EM39-TA-25-F5					ATM-150LD
EM45-TA-32-F5					ATM-175LD
EM52-TA-32-F6					ATM-200LD
EM64-TA-32-F8					ATM-250LD
EM76-TA-40-F12					ATM-300LD
EM90-TA-40-F14					ATM-350LD
EM105-TA-50-F16					ATM-400LD
EM130-TA-50-F20	ATM-500LD				
EM160-TA-50-F24	ATM-600LD				

Shell Mill Replaceable Insert Thread Mills

Tool Number (1)	Locating Disc (2)	Locating Disc Screw (5)	Wedge (3)	Wedge Screw (4)
SM20TA3-F8	ATM139LD	PT464-8IP	ATM-WSM23TAF12	PT464-8IP
SM23TA3-F12	ATM-230LD			
SM25TA-F8	ATM-250LD	PT483T-15IP	ATM-410WL	PT483T-15IP
SMEM64TA-F8	ATM-300LD			
SM30TA-F12				
SMEM76TA-F12	ATM-350LD			
SM35TA-F14				
SMEM90TA-F14	ATM-400LD			
SM40TA-F16				
SMEM105TA-F16	ATM-500LD			
SM50TA-F20				
SM60TA-F24	ATM-600LD			

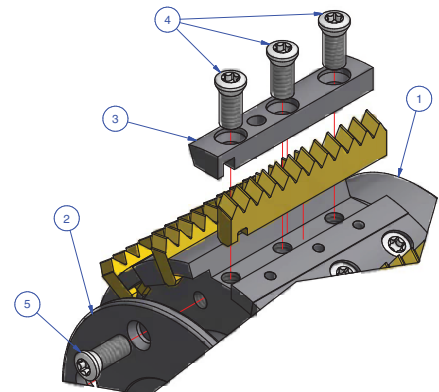

COATINGS AVAILABLE FOR INSERTS AND SOLID CARBIDE TOOLING

- Advent Tool offers various coatings to help with tool wear during the machining process.
- These coatings can be used for cutting ferrous and nonferrous materials and also different types of plastic.
- All coatings are Physical Vapor Deposition or PVD coatings.

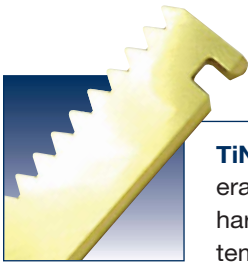

TiN - Titanium Nitride (C) - General purpose coating that increases hardness and has a high oxidation temperature. It is Gold in color.



TiCN - Titanium Carbonitride (Y) - Thin film coating that provides superior wear resistance enabling increased speeds and feeds in almost all applications. Coolant is beneficial when using this coating. The addition of carbon adds hardness and better surface lubricity to the Titanium Nitride. This coating is Pinkish/Copper in color.



TiAlN - Titanium Aluminum Nitride (Z) - A formed layer of aluminum oxide gives this coating the properties that improve tool life in high heat applications (up to 1290°F). This coating is primarily used for carbide tooling where little to no coolant is being used. This coating is Purple/Blue in color.



AlTiN - Aluminum Titanium Nitride - Hardmill (V) - Thin film coating that is specially designed for use in high temperature operations (up to 1650°F). It is also used on materials that are difficult to machine. AlTiN offers a higher surface hardness than TiAlN along with different percentages of aluminum and titanium. This coating is Blueish/ Black in color.

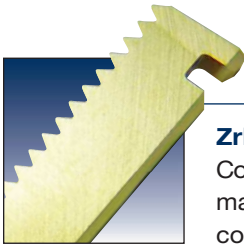

ZrN- Zirconium Nitride (X) - Coating is mostly used with nonferrous material such as aluminum. This coating is Pale Yellow in color.

AlTiN/Si3N4 - Aluminum Titanium Nitride/Silicon Nitride (NT) -

Coating consists of an inner layer of AlTiN for durability and an outside layer Si3N4 for lubricity. It is ideal for machining Titanium and Hardened Materials.

AlCrN - Aluminum Chromium Nitride (NR) -

Superb hot hardness with extraordinary wear resistance even under extreme mechanical stress. The combination of hardness and heat resistance permits tooling to reach new performance levels.

Workpiece Material	Suggested Coating
General Steels	TiN (C), TiAlN (Z), AlTiN (V)
Alloyed Steels	TiAlN (Z), AlTiN (V), AlTiN/Si3N4 (NT)
Magnesium Alloys	TiN (C), TiAlN (Z), AlTiN (V)
Cast Iron	TiAlN (Z), AlTiN (V), AlTiN/Si3N4 (NT)
Titanium Alloys	TiAlN (Z), AlTiN (V), AlTiN/Si3N4 (NT)
Aluminum Alloys	TiAlN (Z)*, AlTiN (V), ZrN (X), TiCN (Y), AlTiN/Si3N4 (NT)

*12% Silicon and Up use (Z) coating

THREADMILL INSERT DESIGNATION



Column 1: **ATM** = Standard Insert Form
SATM = Special Form

Column 2: Insert Size
38A = 0.093" Insert Thickness
1.000" Insert Length
38B = 0.093" Insert Thickness
1.500" Insert Length
410A = 0.130" Insert Thickness
1.500" Insert Length

Column 3: Thread per Inch
Specify Thread Pitch.
Example **8** = 8 Pitch
1.5MM = 1.5mm Pitch

Column 4: Thread Form
Standard Thread Form for
Internal and External Threads
A = External Thread Form ONLY
B = Internal Thread Form ONLY
NPT = NPT Standard Taper Pipe Thread Form
NPTF = NPTF Dryseal Taper Pipe Thread Form
NH = National Hose Thread Form
NPSF = Straight Dryseal Pipe Thread Form
NPSM = Straight Pipe for Mechanical Joints
FA = Full Acme Thread Form
SA = Stub Acme Thread Form
API = API Round Thread Form
BSP = BSP British Standard Pipe Thread Form
BSPT = BSPT British Standard Taper Pipe Thread Form
MM = Metric Thread Form
E2 = One Skipped Tooth

Column 5: Rake Angle
“-” = Neutral Face
P = Positive - Recommended for non-ferrous
or gummy materials, like 1018 steel or
318 stainless. By producing an insert
form with a positive shearing action,
a freer cut is produced, providing for
lower horsepower consumption and
less application sensitivity.

Column 6: Coating
“ ” = Uncoated
C = TiN – (Titanium Nitride)
Y = TiCN – (Titanium Carbonitride)
Z = TiAlN (Titanium Aluminum Nitride)
V = Hardmill (Aluminum Titanium Nitride)
X = ZrN (Zirconium Nitride)

For Coating Descriptions - See Page 17

ORDERING EXAMPLES

ATM-410A12PC

12 pitch UN form with 5 degree positive rake & TiN coating

ATM-38B11.5NPTFZ

11.5 pitch NPTF form with TiAlN coating

SOLID CARBIDE FORM GROUND REPLACEABLE INSERTS

ATM-38A - Unified (UN) Threads

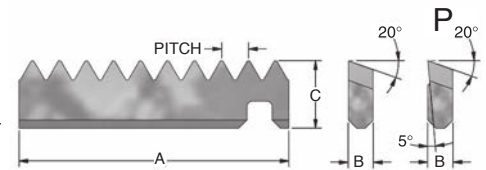

UNIFIED (UN) THREADS

Dimensions in Inches

Part Number	Pitch	Flank Angle	Measurements			Clearance Angle	Coatings Available		
			A	B	C		Uncoated	Z TiAlN	V Hardmill
ATM-38A6	6UN	60	1.000	0.093	0.310	20	X	O	O
ATM-38A6P	6UN	60	1.000	0.093	0.310	20	X	O	O
ATM-38A7	7UN	60	1.000	0.093	0.310	20	X	O	O
ATM-38A7P	7UN	60	1.000	0.093	0.310	20	X	O	O
ATM-38A8	8UN	60	1.000	0.093	0.310	20	X	O	O
ATM-38A8P	8UN	60	1.000	0.093	0.310	20	X	O	O
ATM-38A9	9UN	60	1.000	0.093	0.310	20	X	O	O
ATM-38A9P	9UN	60	1.000	0.093	0.310	20	X	O	O
ATM-38A10	10UN	60	1.000	0.093	0.250	20	X	O	O
ATM-38A10P	10UN	60	1.000	0.093	0.250	20	X	O	O
ATM-38A11	11UN	60	1.000	0.093	0.250	20	X	O	O
ATM-38A11P	11UN	60	1.000	0.093	0.250	20	X	O	O
ATM-38A12	12UN	60	1.000	0.093	0.250	20	X	O	O
ATM-38A12P	12UN	60	1.000	0.093	0.250	20	X	O	O
ATM-38A13	13UN	60	1.000	0.093	0.250	20	X	O	O
ATM-38A13P	13UN	60	1.000	0.093	0.250	20	X	O	O
ATM-38A14	14UN	60	1.000	0.093	0.250	20	X	O	O
ATM-38A14P	14UN	60	1.000	0.093	0.250	20	X	O	O
ATM-38A16	16UN	60	1.000	0.093	0.250	20	X	O	O
ATM-38A16P	16UN	60	1.000	0.093	0.250	20	X	O	O
ATM-38A18	18UN	60	1.000	0.093	0.250	20	X	O	O
ATM-38A18P	18UN	60	1.000	0.093	0.250	20	X	O	O
ATM-38A20	20UN	60	1.000	0.093	0.250	20	X	O	O
ATM-38A20P	20UN	60	1.000	0.093	0.250	20	X	O	O
ATM-38A24	24UN	60	1.000	0.093	0.250	20	X	O	O
ATM-38A24P	24UN	60	1.000	0.093	0.250	20	X	O	O
ATM-38A28	28UN	60	1.000	0.093	0.250	10	X	X	O
ATM-38A28P	28UN	60	1.000	0.093	0.250	10	X	X	O
ATM-38A30	30UN	60	1.000	0.093	0.250	10	X	X	O
ATM-38A30P	30UN	60	1.000	0.093	0.250	10	X	X	O
ATM-38A32	32UN	60	1.000	0.093	0.250	10	X	X	O
ATM-38A32P	32UN	60	1.000	0.093	0.250	10	X	X	O
ATM-38A36	36UN	60	1.000	0.093	0.250	10	X	X	O
ATM-38A36P	36UN	60	1.000	0.093	0.250	10	X	X	O
ATM-38A40	40UN	60	1.000	0.093	0.250	10	X	X	O
ATM-38A40P	40UN	60	1.000	0.093	0.250	10	X	X	O

X = In Stock ; O = Special Order ; Other Coatings Available ; Call for Delivery

SOLID CARBIDE FORM GROUND REPLACEABLE INSERTS

ATM-38B - Unified (UN) Threads

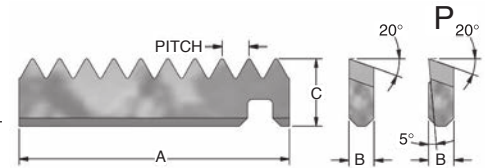

UNIFIED (UN) THREADS

Dimensions in Inches

Part Number	Pitch	Flank Angle	Measurements			Clearance Angle	Coatings Available		
			A	B	C		Uncoated	Z TiAlN	V Hardmill
ATM-38B6	6UN	60	1.500	0.093	0.310	20	X	O	O
ATM-38B6P	6UN	60	1.500	0.093	0.310	20	X	O	O
ATM-38B7	7UN	60	1.500	0.093	0.310	20	X	O	O
ATM-38B7P	7UN	60	1.500	0.093	0.310	20	X	O	O
ATM-38B8	8UN	60	1.500	0.093	0.310	20	X	O	O
ATM-38B8P	8UN	60	1.500	0.093	0.310	20	X	O	O
ATM-38B8/90	8/90	90	1.500	0.093	0.310	20	X	O	O
ATM-38B8/90P	8/90	90	1.500	0.093	0.310	20	X	O	O
ATM-38B9	9UN	60	1.500	0.093	0.310	20	X	O	O
ATM-38B9P	9UN	60	1.500	0.093	0.310	20	X	O	O
ATM-38B10	10UN	60	1.500	0.093	0.250	20	X	O	O
ATM-38B10P	10UN	60	1.500	0.093	0.250	20	X	O	O
ATM-38B11	11UN	60	1.500	0.093	0.250	20	X	O	O
ATM-38B11P	11UN	60	1.500	0.093	0.250	20	X	O	O
ATM-38B12	12UN	60	1.500	0.093	0.250	20	X	O	O
ATM-38B12P	12UN	60	1.500	0.093	0.250	20	X	O	O
ATM-38B13	13UN	60	1.500	0.093	0.250	20	X	O	O
ATM-38B13P	13UN	60	1.500	0.093	0.250	20	X	O	O
ATM-38B14	14UN	60	1.500	0.093	0.250	20	X	O	O
ATM-38B14P	14UN	60	1.500	0.093	0.250	20	X	O	O
ATM-38B16	16UN	60	1.500	0.093	0.250	20	X	O	O
ATM-38B16P	16UN	60	1.500	0.093	0.250	20	X	O	O
ATM-38B16/90	16/90	90	1.500	0.093	0.250	20	X	O	O
ATM-38B16/90P	16/90	90	1.500	0.093	0.250	20	X	O	O
ATM-38B18	18UN	60	1.500	0.093	0.250	20	X	O	O
ATM-38B18P	18UN	60	1.500	0.093	0.250	20	X	O	O
ATM-38B20	20UN	60	1.500	0.093	0.250	20	X	O	O
ATM-38B20P	20UN	60	1.500	0.093	0.250	20	X	O	O
ATM-38B24	24UN	60	1.500	0.093	0.250	20	X	O	O
ATM-38B24P	24UN	60	1.500	0.093	0.250	20	X	O	O
ATM-38B27	27UN	60	1.500	0.093	0.250	10	X	X	O
ATM-38B27P	27UN	60	1.500	0.093	0.250	10	X	X	O
ATM-38B28	28UN	60	1.500	0.093	0.250	10	X	X	O
ATM-38B28P	28UN	60	1.500	0.093	0.250	10	X	X	O
ATM-38B30	30UN	60	1.500	0.093	0.250	10	X	X	O
ATM-38B30P	30UN	60	1.500	0.093	0.250	10	X	X	O
ATM-38B32	32UN	60	1.500	0.093	0.250	10	X	X	O
ATM-38B32P	32UN	60	1.500	0.093	0.250	10	X	X	O
ATM-38B36	36UN	60	1.500	0.093	0.250	10	X	X	O
ATM-38B36P	36UN	60	1.500	0.093	0.250	10	X	X	O
ATM-38B40	40UN	60	1.500	0.093	0.250	10	X	X	O
ATM-38B40P	40UN	60	1.500	0.093	0.250	10	X	X	O

X = In Stock ; O = Special Order ; Other Coatings Available ; Call for Delivery

SOLID CARBIDE FORM GROUND REPLACEABLE INSERTS

ATM-410 - Unified (UN) Threads

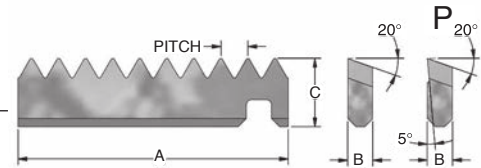

UNIFIED (UN) THREADS

Dimensions in Inches

Part Number	Pitch	Flank Angle	Measurements			Clearance Angle	Coatings Available		
			A	B	C		Uncoated	Z TiAlN	V Hardmill
ATM-410A3B	3UN INT	60	1.500	0.130	0.475	20	X	O	O
ATM-410A3A	3UN EXT	60	1.500	0.130	0.475	20	X	O	O
ATM-410A3.5B	3.5UN INT	60	1.500	0.130	0.425	20	X	O	O
ATM-410A3.5A	3.5UN EXT	60	1.500	0.130	0.425	20	X	O	O
ATM-410A4B	4UN INT	60	1.500	0.130	0.375	20	X	X	O
ATM-410A4BP	4UN INT	60	1.500	0.130	0.375	20	X	O	O
ATM-410A4A	4UN EXT	60	1.500	0.130	0.375	20	X	O	O
ATM-410A4AP	4UN EXT	60	1.500	0.130	0.375	20	X	O	O
ATM-410A4.5B	4.5UN INT	60	1.500	0.130	0.375	20	X	X	O
ATM-410A4.5BP	4.5UN INT	60	1.500	0.130	0.375	20	X	O	O
ATM-410A4.5A	4.5UN EXT	60	1.500	0.130	0.375	20	X	O	O
ATM-410A4.5AP	4.5UN EXT	60	1.500	0.130	0.375	20	X	O	O
ATM-410A5	5UN	60	1.500	0.130	0.375	20	X	X	O
ATM-410A5P	5UN	60	1.500	0.130	0.375	20	X	O	O
ATM-410A6	6UN	60	1.500	0.130	0.375	20	X	X	O
ATM-410A6P	6UN	60	1.500	0.130	0.375	20	X	O	O
ATM-410A7	7UN	60	1.500	0.130	0.375	20	X	X	O
ATM-410A7P	7UN	60	1.500	0.130	0.375	20	X	O	O
ATM-410A8	8UN	60	1.500	0.130	0.375	20	X	X	O
ATM-410A8P	8UN	60	1.500	0.130	0.375	20	X	O	O
ATM-410A8/90	8/90	90	1.500	0.130	0.375	20	X	O	O
ATM-410A8/90P	8/90	90	1.500	0.130	0.375	20	X	O	O
ATM-410A9	9UN	60	1.500	0.130	0.375	20	X	X	O
ATM-410A9P	9UN	60	1.500	0.130	0.375	20	X	O	O
ATM-410A10	10UN	60	1.500	0.130	0.310	20	X	X	O
ATM-410A10P	10UN	60	1.500	0.130	0.310	20	X	O	O
ATM-410A11	11UN	60	1.500	0.130	0.310	20	X	X	O
ATM-410A11P	11UN	60	1.500	0.130	0.310	20	X	O	O
ATM-410A12	12UN	60	1.500	0.130	0.310	20	X	X	O
ATM-410A12P	12UN	60	1.500	0.130	0.310	20	X	O	O
ATM-410A13	13UN	60	1.500	0.130	0.310	20	X	X	O
ATM-410A13P	13UN	60	1.500	0.130	0.310	20	X	O	O
ATM-410A14	14UN	60	1.500	0.130	0.310	20	X	X	O
ATM-410A14P	14UN	60	1.500	0.130	0.310	20	X	O	O
ATM-410A16	16UN	60	1.500	0.130	0.310	20	X	X	O

X = In Stock ; O = Special Order ; Other Coatings Available ; Call for Delivery
continued...

SOLID CARBIDE FORM GROUND REPLACEABLE INSERTS *CONTINUED*

ATM-410 - Unified (UN) Threads

UNIFIED (UN) THREADS *CONTINUED*

Dimensions in Inches

Part Number	Pitch	Flank Angle	Measurements			Clearance Angle	Coatings Available		
			A	B	C		Uncoated	Z TiAlN	V Hardmill
ATM-410A16P	16UN	60	1.500	0.130	0.310	20	X	O	O
ATM-410A16/90	16/90	90	1.500	0.130	0.310	20	X	O	O
ATM-410A16/90P	16/90	90	1.500	0.130	0.310	20	X	O	O
ATM-410A18	18UN	60	1.500	0.130	0.310	20	X	X	O
ATM-410A18P	18UN	60	1.500	0.130	0.310	20	X	O	O
ATM-410A20	20UN	60	1.500	0.130	0.310	20	X	X	O
ATM-410A20P	20UN	60	1.500	0.130	0.310	20	X	O	O
ATM-410A22	22UN	60	1.500	0.130	0.310	20	X	O	O
ATM-410A22P	22UN	60	1.500	0.130	0.310	20	X	O	O
ATM-410A24	24UN	60	1.500	0.130	0.310	20	X	X	O
ATM-410A24P	24UN	60	1.500	0.130	0.310	20	X	O	O
ATM-410A27	27UN	60	1.500	0.130	0.310	10	X	X	O
ATM-410A27P	27UN	60	1.500	0.130	0.310	10	X	X	O
ATM-410A28	28UN	60	1.500	0.130	0.310	10	X	X	O
ATM-410A28P	28UN	60	1.500	0.130	0.310	10	X	X	O
ATM-410A30	30UN	60	1.500	0.130	0.310	10	X	X	O
ATM-410A30P	30UN	60	1.500	0.130	0.310	10	X	X	O
ATM-410A32	32UN	60	1.500	0.130	0.310	10	X	X	O
ATM-410A32P	32UN	60	1.500	0.130	0.310	10	X	X	O
ATM-410A36	36UN	60	1.500	0.130	0.310	10	X	X	O
ATM-410A36P	36UN	60	1.500	0.130	0.310	10	X	X	O
ATM-410A40	40UN	60	1.500	0.130	0.310	10	X	X	O
ATM-410A40P	40UN	60	1.500	0.130	0.310	10	X	X	O

X = In Stock ; O = Special Order ; Other Coatings Available ; Call for Delivery

SOLID CARBIDE FORM GROUND REPLACEABLE INSERTS

ATM-38A & 38B- Metric (M) Threads

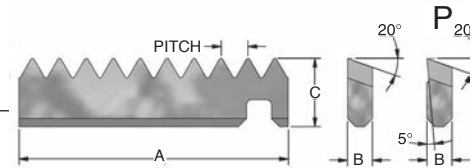

Dimensions in Inches

METRIC (M) THREADS

Part Number	Pitch	Flank Angle	Measurements			Clearance Angle	Coatings Available		
			A	B	C		Uncoated	Z TiAlN	V Hardmill
ATM-38A4.0MM	4.0MM	60	1.000	0.093	0.310	20	X	O	O
ATM-38A4.0MMP	4.0MM	60	1.000	0.093	0.310	20	X	O	O
ATM-38A3.5MM	3.5MM	60	1.000	0.093	0.310	20	X	O	O
ATM-38A3.5MMP	3.5MM	60	1.000	0.093	0.310	20	X	O	O
ATM-38A3.0MM	3.0MM	60	1.000	0.093	0.310	20	X	O	O
ATM-38A3.0MMP	3.0MM	60	1.000	0.093	0.310	20	X	O	O
ATM-38A2.5MM	2.5MM	60	1.000	0.093	0.250	20	X	O	O
ATM-38A2.5MMP	2.5MM	60	1.000	0.093	0.250	20	X	O	O
ATM-38A2.0MM	2.0MM	60	1.000	0.093	0.250	20	X	O	O
ATM-38A2.0MMP	2.0MM	60	1.000	0.093	0.250	20	X	O	O
ATM-38A1.75MM	1.75MM	60	1.000	0.093	0.250	20	X	O	O
ATM-38A1.75MMP	1.75MM	60	1.000	0.093	0.250	20	X	O	O
ATM-38A1.5MM	1.5MM	60	1.000	0.093	0.250	20	X	O	O
ATM-38A1.5MMP	1.5MM	60	1.000	0.093	0.250	20	X	O	O
ATM-38A1.25MM	1.25MM	60	1.000	0.093	0.250	20	X	O	O
ATM-38A1.25MMP	1.25MM	60	1.000	0.093	0.250	20	X	O	O
ATM-38A1.0MM	1.0MM	60	1.000	0.093	0.250	20	X	O	O
ATM-38A1.0MMP	1.0MM	60	1.000	0.093	0.250	20	X	O	O

X = In Stock ; O = Special Order ; Other Coatings Available ; Call for Delivery

METRIC (M) THREADS

ATM-38B4.0MM	4.0MM	60	1.500	0.093	0.310	20	X	O	O
ATM-38B4.0MMP	4.0MM	60	1.500	0.093	0.310	20	X	O	O
ATM-38B3.5MM	3.5MM	60	1.500	0.093	0.310	20	X	O	O
ATM-38B3.5MMP	3.5MM	60	1.500	0.093	0.310	20	X	O	O
ATM-38B3.0MM	3.0MM	60	1.500	0.093	0.310	20	X	O	O
ATM-38B3.0MMP	3.0MM	60	1.500	0.093	0.310	20	X	O	O
ATM-38B2.5MM	2.5MM	60	1.500	0.093	0.250	20	X	O	O
ATM-38B2.5MMP	2.5MM	60	1.500	0.093	0.250	20	X	O	O
ATM-38B2.0MM	2.0MM	60	1.500	0.093	0.250	20	X	O	O
ATM-38B2.0MMP	2.0MM	60	1.500	0.093	0.250	20	X	O	O
ATM-38B1.75MM	1.75MM	60	1.500	0.093	0.250	20	X	O	O
ATM-38B1.75MMP	1.75MM	60	1.500	0.093	0.250	20	X	O	O
ATM-38B1.5MM	1.5MM	60	1.500	0.093	0.250	20	X	O	O
ATM-38B1.5MMP	1.5MM	60	1.500	0.093	0.250	20	X	O	O
ATM-38B1.25MM	1.25MM	60	1.500	0.093	0.250	20	X	O	O
ATM-38B1.25MMP	1.25MM	60	1.500	0.093	0.250	20	X	O	O
ATM-38B1.0MM	1.0MM	60	1.500	0.093	0.250	20	X	O	O
ATM-38B1.0MMP	1.0MM	60	1.500	0.093	0.250	20	X	O	O

X = In Stock ; O = Special Order ; Other Coatings Available

SOLID CARBIDE FORM GROUND REPLACEABLE INSERTS

ATM-410A - Metric (M) Threads

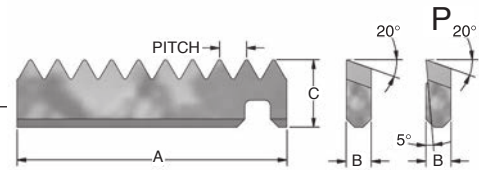

METRIC (M) THREADS

Dimensions in Inches

Part Number	Pitch	Flank Angle	Measurements			Clearance Angle	Coatings Available		
			A	B	C		Uncoated	Z TiAlN	V Hardmill
ATM-410A6.0BMM	6.0MM INT	60	1.500	0.130	0.375	20	X	O	O
ATM-410A6.0BMMP	6.0MM INT	60	1.500	0.130	0.375	20	X	O	O
ATM-410A6.0AMM	6.0MM EXT	60	1.500	0.130	0.375	20	X	O	O
ATM-410A6.0AMMP	6.0MM EXT	60	1.500	0.130	0.375	20	X	O	O
ATM-410A5.0MM	5.0MM	60	1.500	0.130	0.375	20	X	O	O
ATM-410A5.0MMP	5.0MM	60	1.500	0.130	0.375	20	X	O	O
ATM-410A4.5MM	4.5MM	60	1.500	0.130	0.375	20	X	O	O
ATM-410A4.5MMP	4.5MM	60	1.500	0.130	0.375	20	X	O	O
ATM-410A4.0MM	4.0MM	60	1.500	0.130	0.375	20	X	O	O
ATM-410A4.0MMP	4.0MM	60	1.500	0.130	0.375	20	X	O	O
ATM-410A3.5MM	3.5MM	60	1.500	0.130	0.375	20	X	O	O
ATM-410A3.5MMP	3.5MM	60	1.500	0.130	0.375	20	X	O	O
ATM-410A3.0MM	3.0MM	60	1.500	0.130	0.375	20	X	O	O
ATM-410A3.0MMP	3.0MM	60	1.500	0.130	0.375	20	X	O	O
ATM-410A2.5MM	2.5MM	60	1.500	0.130	0.310	20	X	O	O
ATM-410A2.5MMP	2.5MM	60	1.500	0.130	0.310	20	X	O	O
ATM-410A2.0MM	2.0MM	60	1.500	0.130	0.310	20	X	O	O
ATM-410A2.0MMP	2.0MM	60	1.500	0.130	0.310	20	X	O	O
ATM-410A1.75MM	1.75MM	60	1.500	0.130	0.310	20	X	O	O
ATM-410A1.75MMP	1.75MM	60	1.500	0.130	0.310	20	X	O	O
ATM-410A1.5MM	1.5MM	60	1.500	0.130	0.310	20	X	O	O
ATM-410A1.5MMP	1.5MM	60	1.500	0.130	0.310	20	X	O	O
ATM-410A1.25MM	1.25MM	60	1.500	0.130	0.310	20	X	O	O
ATM-410A1.25MMP	1.25MM	60	1.500	0.130	0.310	20	X	O	O
ATM-410A1.0MM	1.0MM	60	1.500	0.130	0.310	20	X	O	O
ATM-410A1.0MMP	1.0MM	60	1.500	0.130	0.310	20	X	O	O

X = In Stock ; O = Special Order ; Other Coatings Available ; Call for Delivery

SOLID CARBIDE FORM GROUND REPLACEABLE INSERTS

Skipped Tooth Inserts (E2) - UN + Metric

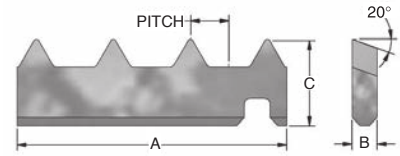

SKIPPED TOOTH INSERTS (E2) - UN + METRIC

Dimensions in Inches

Part Number	Pitch	Flank Angle	Measurements			Clearance Angle	Coatings Available		
			A	B	C		Uncoated	Z TiAlN	V Hardmill
ATM-38A7E2	7UN	60	1.000	0.093	0.310	20	X	X	O
ATM-38A8E2	8UN	60	1.000	0.093	0.310	20	X	X	O
ATM-410A4E2	4UN	60	1.500	0.130	0.375	20	X	X	O
ATM-410A4.5E2	4.5UN	60	1.500	0.130	0.375	20	X	X	O
ATM-410A5E2	5UN	60	1.500	0.130	0.375	20	X	X	O
ATM-410A6E2	6UN	60	1.500	0.130	0.375	20	X	X	O
ATM-410A7E2	7UN	60	1.500	0.130	0.375	20	X	X	O
ATM-410A8E2	8UN	60	1.500	0.130	0.375	20	X	X	O
ATM-38A3.5MME2	3.5MM	60	1.000	0.093	0.310	20	X	X	O
ATM-38A3.0MME2	3.0MM	60	1.000	0.093	0.280	20	X	X	O
ATM-410A6.0MME2	6.0MM	60	1.500	0.130	0.375	20	X	X	O
ATM-410A5.0MME2	5.0MM	60	1.500	0.130	0.375	20	X	X	O
ATM-410A4.5MME2	4.5MM	60	1.500	0.130	0.375	20	X	X	O
ATM-410A4.0MME2	4.0MM	60	1.500	0.130	0.375	20	X	X	O
ATM-410A3.5MME2	3.5MM	60	1.500	0.130	0.375	20	X	X	O
ATM-410A3.0MME2	3.0MM	60	1.500	0.130	0.375	20	X	X	O

X = In Stock ; O = Special Order ; Other Coatings Available

SOLID CARBIDE FORM GROUND REPLACEABLE INSERTS

Full ACME (FA) Internal & External Threads

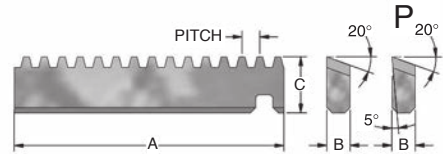

FULL ACME (FA) INTERNAL THREADS

Dimensions in Inches

Part Number	Pitch	Flank Angle	Measurements			Clearance Angle	Coatings Available		
			A	B	C		Uncoated	Z TiAlN	V Hardmill
ATM-410A3FA	3FA INT	29	1.500	0.130	0.408	20	X	O	O
ATM-410A3FAP	3FA INT	29	1.500	0.130	0.408	20	X	O	O
ATM-410A3.5FA	3.5FA INT	29	1.500	0.130	0.375	20	X	O	O
ATM-410A3.5FAP	3.5FA INT	29	1.500	0.130	0.375	20	X	O	O
ATM-410A4FA	4FA INT	29	1.500	0.130	0.375	20	X	X	O
ATM-410A4FAP	4FA INT	29	1.500	0.130	0.375	20	X	O	O
ATM-410A5FA	5FA INT	29	1.500	0.130	0.375	20	X	X	O
ATM-410A5FAP	5FA INT	29	1.500	0.130	0.375	20	X	O	O
ATM-410A6FA	6FA INT	29	1.500	0.130	0.375	20	X	X	O
ATM-410A6FAP	6FA INT	29	1.500	0.130	0.375	20	X	O	O
ATM-410A8FA	8FA INT	29	1.500	0.130	0.375	20	X	X	O
ATM-410A8FAP	8FA INT	29	1.500	0.130	0.375	20	X	O	O
ATM-410A10FA	10FA INT	29	1.500	0.130	0.310	20	X	O	O
ATM-410A10FAP	10FA INT	29	1.500	0.130	0.310	20	X	O	O
ATM-410A12FA	12FA INT	29	1.500	0.130	0.310	20	X	O	O
ATM-410A12FAP	12FA INT	29	1.500	0.130	0.310	20	X	O	O

X = In Stock ; O = Special Order ; Other Coatings Available ; Call for Delivery

FULL ACME (FA) EXTERNAL THREADS

ATM-410A3AFA	3FA EXT	29	1.500	0.130	0.408	20	X	O	O
ATM-410A3AFAP	3FA EXT	29	1.500	0.130	0.408	20	X	O	O
ATM-410A3.5AFA	3.5FA EXT	29	1.500	0.130	0.408	20	X	O	O
ATM-410A3.5AFAP	3.5FA EXT	29	1.500	0.130	0.408	20	X	O	O
ATM-410A4AFA	4FA EXT	29	1.500	0.130	0.408	20	X	O	O
ATM-410A4AFAP	4FA EXT	29	1.500	0.130	0.408	20	X	O	O
ATM-410A5AFA	5FA EXT	29	1.500	0.130	0.375	20	X	O	O
ATM-410A5AFAP	5FA EXT	29	1.500	0.130	0.375	20	X	O	O
ATM-410A6AFA	6FA EXT	29	1.500	0.130	0.375	20	X	O	O
ATM-410A6AFAP	6FA EXT	29	1.500	0.130	0.375	20	X	O	O
ATM-410A8AFA	8FA EXT	29	1.500	0.130	0.375	20	X	O	O
ATM-410A8AFAP	8FA EXT	29	1.500	0.130	0.375	20	X	O	O
ATM-410A10AFA	10FA EXT	29	1.500	0.130	0.310	20	X	O	O
ATM-410A10AFAP	10FA EXT	29	1.500	0.130	0.310	20	X	O	O
ATM-410A12AFA	12FA EXT	29	1.500	0.130	0.310	20	X	O	O
ATM-410A12AFAP	12FA EXT	29	1.500	0.130	0.310	20	X	O	O

X = In Stock ; O = Special Order ; Other Coatings Available

SOLID CARBIDE FORM GROUND REPLACEABLE INSERTS

STUB Acme (SA) Threads

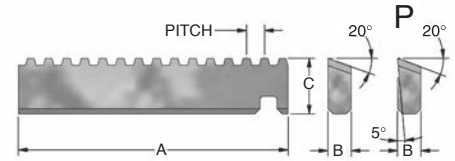

STUB ACME (SA) THREADS

Dimensions in Inches

Part Number	Pitch	Flank Angle	Measurements			Clearance Angle	Coatings Available		
			A	B	C		Uncoated	Z TiAlN	V Hardmill
ATM-410A3SA	3SA	29	1.500	0.130	0.375	20	X	O	O
ATM-410A4SA	4SA	29	1.500	0.130	0.375	20	X	O	O
ATM-410A4SAP	4SA	29	1.500	0.130	0.375	20	X	O	O
ATM-410A5SA	5SA	29	1.500	0.130	0.375	20	X	O	O
ATM-410A5SAP	5SA	29	1.500	0.130	0.375	20	X	O	O
ATM-410A6SA	6SA	29	1.500	0.130	0.375	20	X	O	O
ATM-410A6SAP	6SA	29	1.500	0.130	0.375	20	X	O	O
ATM-410A8SA	8SA	29	1.500	0.130	0.375	20	X	O	O
ATM-410A8SAP	8SA	29	1.500	0.130	0.375	20	X	O	O
ATM-410A10SA	10SA	29	1.500	0.130	0.310	20	X	O	O
ATM-410A10SAP	10SA	29	1.500	0.130	0.310	20	X	O	O
ATM-410A12SA	12SA	29	1.500	0.130	0.310	20	X	O	O
ATM-410A12SAP	12SA	29	1.500	0.130	0.310	20	X	O	O

X = In Stock ; O = Special Order ; Other Coatings Available ; Call for Delivery

SOLID CARBIDE FORM GROUND REPLACEABLE INSERTS

National Taper Pipe (NPT) Threads

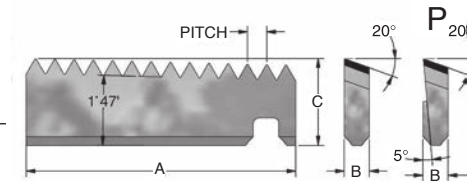

NATIONAL TAPER PIPE (NPT) THREADS

Dimensions in Inches

Part Number	Pitch	Flank Angle	Measurements			Clearance Angle	Coatings Available		
			A	B	C		Uncoated	Z TiAlN	V Hardmill
ATM-38A18NPT	18NPT	60	1.000	0.093	0.310	20	X	O	O
ATM-38A18NPTP	18NPT	60	1.000	0.093	0.310	20	X	O	O
ATM-38A14NPT	14NPT	60	1.000	0.093	0.310	20	X	X	O
ATM-38A14NPTP	14NPT	60	1.000	0.093	0.310	20	X	O	O
ATM-38A11.5NPT	11.5NPT	60	1.000	0.093	0.310	20	X	X	O
ATM-38A11.5NPTP	11.5NPT	60	1.000	0.093	0.310	20	X	O	O
ATM-38B18NPT	18NPT	60	1.500	0.093	0.310	20	X	O	O
ATM-38B18NPTP	18NPT	60	1.500	0.093	0.310	20	X	O	O
ATM-38B14NPT	14NPT	60	1.500	0.093	0.310	20	X	X	O
ATM-38B14NPTP	14NPT	60	1.500	0.093	0.310	20	X	O	O
ATM-38B11.5NPT	11.5NPT	60	1.500	0.093	0.310	20	X	X	O
ATM-38B11.5NPTP	11.5NPT	60	1.500	0.093	0.310	20	X	O	O
ATM-38B8NPT	8NPT	60	1.500	0.093	0.310	20	X	X	O
ATM-38B8NPTP	8NPT	60	1.500	0.093	0.310	20	X	O	O
ATM-410A18NPT	18NPT	60	1.500	0.130	0.375	20	X	X	O
ATM-410A18NPTP	18NPT	60	1.500	0.130	0.375	20	X	O	O
ATM-410A14NPT	14NPT	60	1.500	0.130	0.375	20	X	X	O
ATM-410A14NPTP	14NPT	60	1.500	0.130	0.375	20	X	O	O
ATM-410A11.5NPT	11.5NPT	60	1.500	0.130	0.375	20	X	X	O
ATM-410A11.5NPTP	11.5NPT	60	1.500	0.130	0.375	20	X	O	O
ATM-410A8NPT	8NPT	60	1.500	0.130	0.375	20	X	X	O
ATM-410A8NPTP	8NPT	60	1.500	0.130	0.375	20	X	O	O

X = In Stock ; O = Special Order ; Other Coatings Available ; Call for Delivery

SOLID CARBIDE FORM GROUND REPLACEABLE INSERTS

Dryseal Pipe (NPTF) Threads

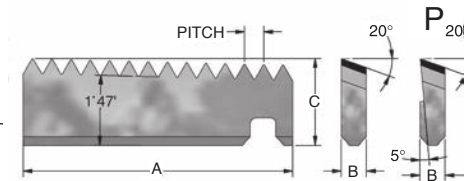

DRYSEAL PIPE (NPTF) THREADS

Dimensions in Inches

Part Number	Pitch	Flank Angle	Measurements			Clearance Angle	Coatings Available		
			A	B	C		Uncoated	Z TiAlN	V Hardmill
ATM-38A27NPTF	27NPTF	60	1.000	0.093	0.310	10	X	O	O
ATM-38A18NPTF	18NPTF	60	1.000	0.093	0.310	20	X	O	O
ATM-38A18NPTFP	18NPTF	60	1.000	0.093	0.310	20	X	O	O
ATM-38A14NPTF	14NPTF	60	1.000	0.093	0.310	20	X	X	O
ATM-38A14NPTFP	14NPTF	60	1.000	0.093	0.310	20	X	O	O
ATM-38A11.5NPTF	11.5NPTF	60	1.000	0.093	0.310	20	X	X	O
ATM-38A11.5NPTFP	11.5NPTF	60	1.000	0.093	0.310	20	X	O	O
ATM-38B18NPTF	18NPTF	60	1.500	0.093	0.310	20	X	O	O
ATM-38B18NPTFP	18NPTF	60	1.500	0.093	0.310	20	X	O	O
ATM-38B14NPTF	14NPTF	60	1.500	0.093	0.310	20	X	X	O
ATM-38B14NPTFP	14NPTF	60	1.500	0.093	0.310	20	X	O	O
ATM-38B11.5NPTF	11.5NPTF	60	1.500	0.093	0.310	20	X	X	O
ATM-38B11.5NPTFP	11.5NPTF	60	1.500	0.093	0.310	20	X	O	O
ATM-38B8NPTF	8NPTF	60	1.500	0.093	0.310	20	X	X	O
ATM-38B8NPTFP	8NPTF	60	1.500	0.093	0.310	20	X	O	O
ATM-410A18NPTF	18NPTF	60	1.500	0.130	0.375	20	X	X	O
ATM-410A18NPTFP	18NPTF	60	1.500	0.130	0.375	20	X	O	O
ATM-410A14NPTF	14NPTF	60	1.500	0.130	0.375	20	X	X	O
ATM-410A14NPTFP	14NPTF	60	1.500	0.130	0.375	20	X	O	O
ATM-410A11.5NPTF	11.5NPTF	60	1.500	0.130	0.375	20	X	X	O
ATM-410A11.5NPTFP	11.5NPTF	60	1.500	0.130	0.375	20	X	O	O
ATM-410A8NPTF	8NPTF	60	1.500	0.130	0.375	20	X	X	O
ATM-410A8NPTFP	8NPTF	60	1.500	0.130	0.375	20	X	O	O

X = In Stock ; O = Special Order ; Other Coatings Available ; Call for Delivery

SOLID CARBIDE FORM GROUND REPLACEABLE INSERTS

National Straight Pipe (NPS) Threads

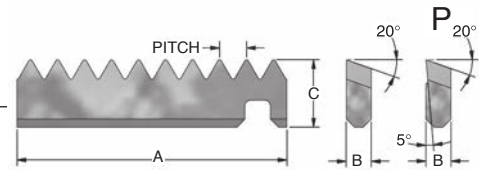

NATIONAL STRAIGHT PIPE (NPS) THREADS

Dimensions in Inches

Part Number	Pitch	Flank Angle	Measurements			Clearance Angle	Coatings Available		
			A	B	C		Uncoated	Z TiAlN	V Hardmill
ATM-38A27NPS	27NPS	60	1.000	0.093	0.250	10	X	O	O
ATM-38A27NPSP	27NPS	60	1.000	0.093	0.250	10	X	O	O
ATM-38A18NPS	18NPS	60	1.000	0.093	0.250	20	X	O	O
ATM-38A18NPSP	18NPS	60	1.000	0.093	0.250	20	X	O	O
ATM-38A14NPS	14NPS	60	1.000	0.093	0.250	20	X	O	O
ATM-38A14NPSP	14NPS	60	1.000	0.093	0.250	20	X	O	O
ATM-38A11.5NPS	11.5NPS	60	1.000	0.093	0.250	20	X	O	O
ATM-38A11.5NPSP	11.5NPS	60	1.000	0.093	0.250	20	X	O	O

ATM-38B18NPS	18NPS	60	1.500	0.093	0.250	20	X	O	O
ATM-38B18NPSP	18NPS	60	1.500	0.093	0.250	20	X	O	O
ATM-38B14NPS	14NPS	60	1.500	0.093	0.250	20	X	O	O
ATM-38B14NPSP	14NPS	60	1.500	0.093	0.250	20	X	O	O
ATM-38B11.5NPS	11.5NPS	60	1.500	0.093	0.250	20	X	O	O
ATM-38B11.5NPSP	11.5NPS	60	1.500	0.093	0.250	20	X	O	O
ATM-38B8NPS	8NPS	60	1.500	0.093	0.310	20	X	O	O
ATM-38B8NPSP	8NPS	60	1.500	0.093	0.310	20	X	O	O

ATM-410A18NPS	18NPS	60	1.500	0.130	0.310	20	X	O	O
ATM-410A18NPSP	18NPS	60	1.500	0.130	0.310	20	X	O	O
ATM-410A14NPS	14NPS	60	1.500	0.130	0.310	20	X	O	O
ATM-410A14NPSP	14NPS	60	1.500	0.130	0.310	20	X	O	O
ATM-410A11.5NPS	11.5NPS	60	1.500	0.130	0.310	20	X	O	O
ATM-410A11.5NPSP	11.5NPS	60	1.500	0.130	0.310	20	X	O	O
ATM-410A8NPS	8NPS	60	1.500	0.130	0.375	20	X	O	O
ATM-410A8NPSP	8NPS	60	1.500	0.130	0.375	20	X	O	O

X = In Stock ; O = Special Order ; Other Coatings Available ; Call for Delivery

SOLID CARBIDE FORM GROUND REPLACEABLE INSERTS

Dryseal Straight Pipe (NPSF) Threads

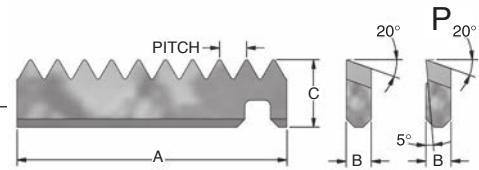

DRYSEAL STRAIGHT PIPE (NPSF) THREADS

Dimensions in Inches

Part Number	Pitch	Flank Angle	Measurements			Clearance Angle	Coatings Available		
			A	B	C		Uncoated	Z TiAlN	V Hardmill
ATM-38A18NPSF	18NPSF	60	1.000	0.093	0.250	20	X	O	O
ATM-38A18NPSFP	18NPSF	60	1.000	0.093	0.250	20	X	O	O
ATM-38A14NPSF	14NPSF	60	1.000	0.093	0.250	20	X	O	O
ATM-38A14NPSFP	14NPSF	60	1.000	0.093	0.250	20	X	O	O
ATM-38A11.5NPSF	11.5NPSF	60	1.000	0.093	0.250	20	X	O	O
ATM-38A11.5NPSFP	11.5NPSF	60	1.000	0.093	0.250	20	X	O	O
ATM-38B18NPSF	18NPSF	60	1.500	0.093	0.250	20	X	O	O
ATM-38B18NPSFP	18NPSF	60	1.500	0.093	0.250	20	X	O	O
ATM-38B14NPSF	14NPSF	60	1.500	0.093	0.250	20	X	O	O
ATM-38B14NPSFP	14NPSF	60	1.500	0.093	0.250	20	X	O	O
ATM-38B11.5NPSF	11.5NPSF	60	1.500	0.093	0.250	20	X	O	O
ATM-38B11.5NPSFP	11.5NPSF	60	1.500	0.093	0.250	20	X	O	O
ATM-38B8NPSF	8NPSF	60	1.500	0.093	0.310	20	X	O	O
ATM-38B8NPSFP	8NPSF	60	1.500	0.093	0.310	20	X	O	O
ATM-410A18NPSF	18NPSF	60	1.500	0.130	0.310	20	X	O	O
ATM-410A18NPSFP	18NPSF	60	1.500	0.130	0.310	20	X	O	O
ATM-410A14NPSF	14NPSF	60	1.500	0.130	0.310	20	X	O	O
ATM-410A14NPSFP	14NPSF	60	1.500	0.130	0.310	20	X	O	O
ATM-410A11.5NPSF	11.5NPSF	60	1.500	0.130	0.310	20	X	O	O
ATM-410A11.5NPSFP	11.5NPSF	60	1.500	0.130	0.310	20	X	O	O
ATM-410A8NPSF	8NPSF	60	1.500	0.130	0.375	20	X	O	O
ATM-410A8NPSFP	8NPSF	60	1.500	0.130	0.375	20	X	O	O

X = In Stock ; O = Special Order ; Other Coatings Available ; Call for Delivery

SOLID CARBIDE FORM GROUND REPLACEABLE INSERTS

British Standard Parallel Pipe (BSPP) and
British Standard Pipe Taper (BSPT)

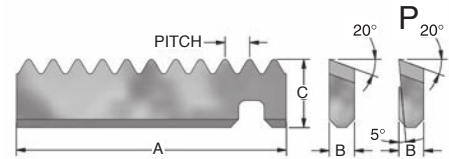

BRITISH STANDARD PARALLEL PIPE (BSPP)

Dimensions in Inches

Part Number	Pitch	Flank Angle	Measurements			Clearance Angle	Coatings Available		
			A	B	C		Uncoated	Z TiAlN	V Hardmill
ATM-38A14BSP	14BSP	55	1.000	0.093	0.250	20	X	O	O
ATM-38A14BSPP	14BSP	55	1.000	0.093	0.250	20	X	O	O
ATM-38A11BSP	11BSP	55	1.000	0.093	0.250	20	X	O	O
ATM-38A11BSPP	11BSP	55	1.000	0.093	0.250	20	X	O	O

ATM-38B14BSP	14BSP	55	1.500	0.093	0.250	20	X	O	O
ATM-38B14BSPP	14BSP	55	1.500	0.093	0.250	20	X	O	O
ATM-38B11BSP	11BSP	55	1.500	0.093	0.250	20	X	O	O
ATM-38B11BSPP	11BSP	55	1.500	0.093	0.250	20	X	O	O

ATM-410A14BSP	14BSP	55	1.500	0.130	0.310	20	X	O	O
ATM-410A14BSPP	14BSP	55	1.500	0.130	0.310	20	X	O	O
ATM-410A11BSP	11BSP	55	1.500	0.130	0.310	20	X	O	O
ATM-410A11BSPP	11BSP	55	1.500	0.130	0.310	20	X	O	O

X = In Stock ; O = Special Order ; Other Coatings Available

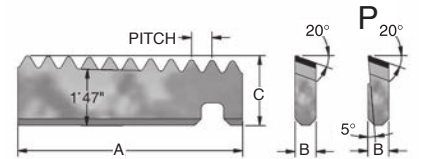

BRITISH STANDARD PIPE TAPER (BSPT) THREADS

ATM-38A14BSPT	14BSP	55	1.000	0.093	0.310	20	X	O	O
ATM-38A14BSPTP	14BSP	55	1.000	0.093	0.310	20	X	O	O
ATM-38A11BSPT	11BSP	55	1.000	0.093	0.310	20	X	O	O
ATM-38A11BSPTP	11BSP	55	1.000	0.093	0.310	20	X	O	O

ATM-38B14BSPT	14BSP	55	1.500	0.093	0.310	20	X	O	O
ATM-38B14BSPTP	14BSP	55	1.500	0.093	0.310	20	X	O	O
ATM-38B11BSPT	11BSP	55	1.500	0.093	0.310	20	X	O	O
ATM-38B11BSPTP	11BSP	55	1.500	0.093	0.310	20	X	O	O

ATM-410A14BSPT	14BSP	55	1.500	0.130	0.375	20	X	O	O
ATM-410A14BSPTP	14BSP	55	1.500	0.130	0.375	20	X	O	O
ATM-410A11BSPT	11BSP	55	1.500	0.130	0.375	20	X	O	O
ATM-410A11BSPTP	11BSP	55	1.500	0.130	0.375	20	X	O	O

X = In Stock ; O = Special Order ; Other Coatings Available

SOLID CARBIDE FORM GROUND REPLACEABLE INSERTS

American Petroleum Institute Round (API) Threads

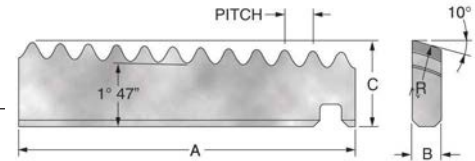

AMERICAN PETROLEUM INSTITUTE ROUND (API) THREADS

Dimensions in Inches

Part Number	Pitch	Flank Angle	Measurements			Clearance Angle	Coatings Available		
			A	B	C		Uncoated	Z TiAlN	V Hardmill
ATM-410A8API	8API	60	1.500	0.130	0.375	10	O	X	O
ATM-410A10API	10API	60	1.500	0.130	0.375	10	O	X	O

X = In Stock ; O = Special Order ; Other Coatings Available

SOLID CARBIDE FORM GROUND REPLACEABLE INSERTS

American Buttress Threads (Internal/External)

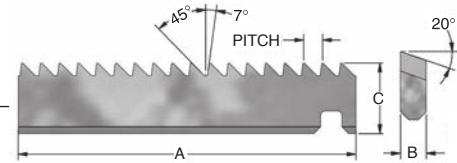

AMERICAN BUTTRESS THREADS (INTERNAL/EXTERNAL)

Dimensions in Inches

Part Number	Pitch	Flank Angle	Measurements			Clearance Angle	Coatings Available		
			A	B	C		Uncoated	Z TiAlN	V Hardmill
ATM-6B-7/45	6BUTT	52	1.500	0.130	0.375	10	O	X	O
ATM-8B-7/45	8BUTT	52	1.500	0.130	0.375	10	O	X	O
ATM-10B-7/45	10BUTT	52	1.500	0.130	0.310	10	O	X	O
ATM-12B-7/45	12BUTT	52	1.500	0.130	0.310	10	O	X	O
ATM-16B-7/45	16BUTT	52	1.500	0.130	0.310	10	O	X	O
ATM-20B-7/45	20BUTT	52	1.500	0.130	0.310	10	O	X	O

X = In Stock ; O = Special Order ; Other Coatings Available

For Buttress Thread Inserts 6 - 20 pitch use Standard Replaceable Insert Thread Mill Tools (Insert Style ATM-410A)

For Buttress Thread Inserts 1 - 5 pitch use Special Holder for each Buttress Thread Pitch

Insert Style ATM-38A & ATM-38B available upon request

Coarse Pitch & Different Flank Angle Buttress Thread Form available upon request

QUADMILL DESIGNATION



Column 1: **RM** = Standard Quadmill Tool
SRM = Special Quadmill Tool

Column 2: Thread Milling Tool Size

10 = 1.000"
125 = 1.250"
15 = 1.500"
175 = 1.75"
20 = 2.000"
25 = 2.500"
30 = 3.000"
35 = 3.500"
40 = 4.000"

Column 3: Tool Shank Size

10 = Weldon Shank Ø1.000"
125 = Weldon Shank Ø1.250"
20 = Weldon Shank Ø2.000"
25MM = Weldon Shank Ø25.0mm
32MM = Weldon Shank Ø32.0mm
50MM = Weldon Shank Ø50.0mm
C50 = CAT 50 Holder

Column 4: Number of Flutes

F4 = 4 Flutes Tool
F5 = 5 Flutes Tool
F6 = 6 Flutes Tool
F10 = 10 Flutes Tool
F14 = 14 Flutes Tool

Column 5: Tool Length Weldon Shank Tools: Over All Length (OAL)

Extended Length Tools Only
9 = 9: OAL - Extended Length Tool

CAT Tools:

Length From Gauge Line (FGL)

4 = 4.0" FGL
5 = 5.0" FGL
6 = 6.0" FGL
7 = 7.0" FGL
8 = 8.0" FGL

Useable Length is about 1.5" shorter

QUADMILLS

Replaceable Carbide Helical Roughing, Semi-finishing, Finishing and Thread Mill Inserts

- Through Coolant
- Standard Weldon Shank
- Hardened and CNC Ground
- 10 Degree Helix

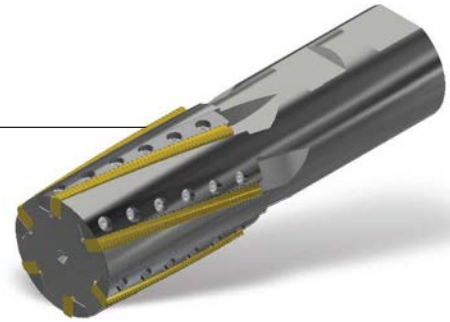

Dimensions in Inches (mm)

Part Number	Cutter Diameter* (d)	Length (l) of Cut	Number of Flutes	Tool (L) Length	Shank (D) Diameter
RM10-10-F4	1.000 (25.40)	1.0 (25)	4	4.0 (102)	1.000
RM125-10-F4	1.250 (31.75)	1.5 (38)	4	4.5 (114)	1.000
RM15-125-F5	1.500 (38.10)	2.0 (51)	5	5.0 (127)	1.250
RM175-125-F6	1.750 (44.45)	2.0 (51)	6	5.0 (127)	1.250
RM20-20-F6	2.000 (50.80)	3.0 (76)	6	6.7 (171)	2.000
RM30-20-F10	3.000 (76.20)	3.0 (76)	10	7.0 (178)	2.000
RM40-20-F14	4.000 (101.60)	3.0 (76)	14	7.0 (178)	2.000

* Cutter Diameter and Length of Cut - see: Quadmill Tool - Inserts

QUADMILLS, METRIC SHANK

Part Number	Cutter Diameter* (d)	Length (l) of Cut	Number of Flutes	Tool (L) Length	Shank (D) Diameter
RM10-25MM-F4	1.000 (25.40)	1.0 (25)	4	4.0 (102)	(25)
RM125-25MM-F4	1.250 (31.75)	1.5 (38)	4	4.5 (114)	(25)
RM15-32MM-F5	1.500 (38.10)	2.0 (51)	5	5.0 (127)	(32)
RM175-32MM-F6	1.750 (44.45)	2.0 (51)	6	5.0 (127)	(32)
RM20-50MM-F6	2.000 (50.80)	3.0 (76)	6	6.75 (171)	(50)
RM30-50MM-F10	3.000 (76.20)	3.0 (76)	10	7.0 (178)	(50)
RM40-50MM-F14	4.000 (101.60)	3.0 (76)	14	7.0 (178)	(50)

* Cutter Diameter and Length of Cut - see: Quadmill Tool - Inserts

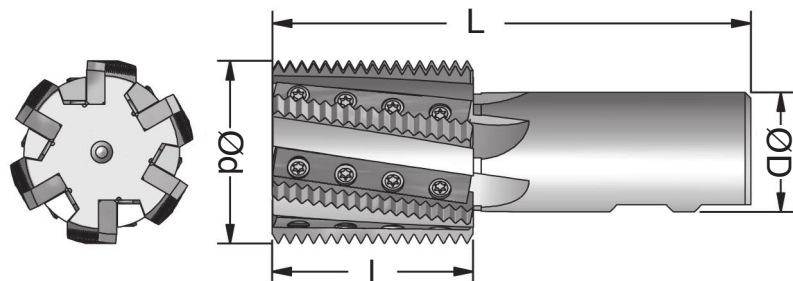

REPLACEABLE CARBIDE HELICAL ROUGHING, SEMI-FINISHING, FINISHING AND THREAD MILL INSERTS



Replaceable Carbide Helical Roughing, Semi-finishing, Finishing and Thread Mill Inserts

- Through Coolant
- Standard V-flange with Integral Shank
- 10 Degree Helix
- Hardened and CNC Ground

CV-50 MILLS

Dimensions in Inches (mm)

Part Number	Cutter Diameter* (d)	Length (l) of Cut	Number of Flutes	Length From Gauge Line	Useable Cutter Length
RM15-C50-F5-5	1.500 (38.10)	2.0 (51)	5	5 (127)	3.5 (89)
RM15-C50-F5-6				6 (152)	4.5 (114)
RM175-C50-F6-5	1.750 (44.45)	2.0 (51)	6	5 (127)	3.5 (89)
RM175-C50-F6-6				6 (152)	4.5 (114)
RM175-C50-F6-7				7 (178)	5.5 (140)
RM20-C50-F6-6	2.000 (50.80)	3.0 (76)	6	6 (152)	4.5 (114)
RM20-C50-F6-7				7 (178)	5.5 (140)
RM20-C50-F6-8				8 (203)	6.5 (165)
RM30-C50-F10-6	3.000 (76.20)	3.0 (76)	10	6 (152)	4.5 (114)
RM30-C50-F10-7				7 (178)	5.5 (140)
RM30-C50-F10-8				8 (203)	6.5 (165)
RM40-C50-F14-6	4.000 (101.60)	3.0 (76)	14	6 (152)	4.5 (114)
RM40-C50-F14-7				7 (178)	5.5 (140)
RM40-C50-F14-8				8 (203)	6.5 (165)

* Cutter Diameter and Length of Cut - see: Quadmill Tool - Inserts

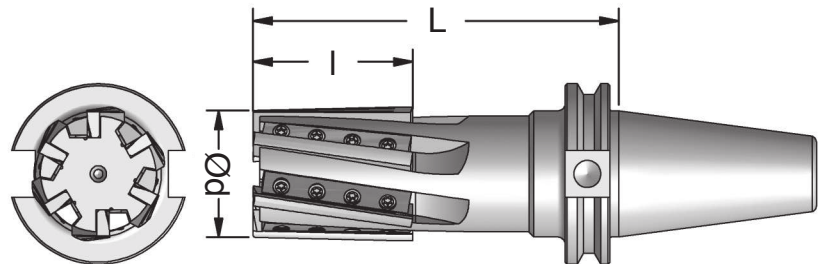

QUADMILL REPLACEMENT PARTS

All screws used on Replaceable Insert Mills are Torx Plus Screws.



Part Number	Locating Pin	Wedge	Wedge Screw
RM10-10-F4 RM10-25MM-F4	ATM-PINRM10S	ATM-WRM10SH2	PT464-8IP
RM125-10-F4 RM125-25MM-F4	ATM-PINRM12L	ATM-WRM12LH3	PT483T-15IP
RM15-125-F5 RM15-32MM-F5 RM15-C50-F5-x	ATM-PINRMR	ATM-WRM15RH4	PT483T-15IP
RM175-125-F6 RM175-32MM-F6 RM175-C50-F6-x	ATM-PINRMR	ATM-WRM175RH4	PT483T-15IP
RM20-20-F6 RM20-50MM-F6 RM20-C50-F6-x	ATM-PINRMR	ATM-WRM20RH6	PT483T-15IP
RM30-20-F10 RM30-50MM-F10 RM30-C50-F10-x	ATM-PINRMR	ATM-WRM30RH6	PT483T-15IP
RM40-20-F14 RM40-50MM-F14 RM40-C50-F14-x	ATM-PINRMR	ATM-WRM40RH6	PT483T-15IP

QUADMILL INSERT DESIGNATION



Column 1: I = Regular Insert Form
SI = Special Form

Column 2: Insert Style
R = Roughing Mill Insert
S = Semi-finishing Mill Insert
F = Finishing Mill Insert
T = Thread Form Insert

Column 3: Carbide Insert Thickness
S = 0.093 - Insert Thickness
L = 0.130 - Insert Thickness
R = 0.188 - Insert Thickness

Column 4: Tool Standard Cutter Diameter
10 = 1.000"
125 = 1.250"
15 = 1.500"
175 = 1.750"
20 = 2.000"
30 = 3.000"
40 = 4.000"

Column 5: Thread Pitch (Thread Form Insert Only)
8 = 8 Pitch
1.5MM = 1.5mm Pitch

Column 6: Thread Form (Thread Form Insert Only)
A = External Thread Form
B = Internal Thread Form
NPT = NPT Thread Form
NPTF = NPTF Thread Form
BSP = BSP Thread Form
BSPT = BSPT Thread Form

Column 7: Insert Length of Cut
10 = 1.0"
15 = 1.5"
20 = 2.0"
30 = 3.0"

Column 8: For Coating Descriptions See Page 17.

QUADMILL INSERTS

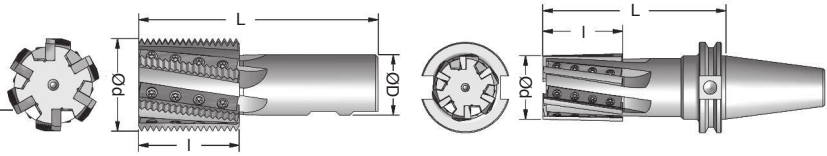

Dimensions in Inches (mm)

Part Number	Tool Style	Thread Form	Insert*** # Example	Tool Cutter Diameter (d)	Insert Height	Insert Thickness	Length of Cut (l)
RM10-10-F4 RM10-25MM-F4	Roughing	-	IRS10-10C	1.000 (25.40)	.250 (6.35)	.093 (2.36)	1.0 (25)
	Semi-Finishing	-	ISS10-10C	1.000 (25.40)	.250 (6.35)	.093 (2.36)	1.0 (25)
	Finishing	-	IFS10-10C	1.000 (25.40)	.250 (6.35)	.093 (2.36)	1.0 (25)
	Thread Mill	32UN-14UN** 0.75mm-1.75mm** 28BSP-14BSP	ITS10-1.5MMB-10C	1.000 (25.40)	.250 (6.35)	.093 (2.36)	1.0 (25)
		13UN-8UN** 2.0mm-3.5mm** 27NPT(F)-11.5NPT(F) 11BSP, 28BSPT-11BSPT	ITS10-8B-10C	1.100 (27.94)	.300 (7.62)	.093 (2.36)	1.0 (25)
RM125-10-F4 RM125-25MM-F4	Roughing	-	IRL125-15C	1.250 (31.75)	.325 (8.26)	.130 (3.30)	1.5 (38)
	Semi-Finishing	-	ISL125-15C	1.250 (31.75)	.325 (8.26)	.130 (3.30)	1.5 (38)
	Finishing	-	IFL125-15C	1.250 (31.75)	.325 (8.26)	.130 (3.30)	1.5 (38)
	Thread Mill	32UN-14UN** 0.75mm-1.75mm** 28BSP-14BSP	ITL125-1.5mmB-15C	1.250 (31.75)	.325 (8.26)	.130 (3.30)	1.5 (38)
		13UN-8UN** 2.0mm-3.5mm** 11BSP	ITL125-8B-15C	1.350 (34.29)	.375 (9.53)	.130 (3.30)	1.5 (38)
7UN-4UN** 4.0m-6.0mm** all NPT, NPTF * BSPT	ITL125-8NPT-15C	1.450 (36.83)	.425 (10.80)	.130 (3.30)	1.5 (38)		
RM15-125-F5 RM15-32MM-F5 RM15-C50-F5-5 RM15-C50-F5-6	Roughing	-	IRR15-20C	1.500 (38.10)	.375 (9.53)	.188 (4.78)	2.0 (51)
	Semi-Finishing	-	ISR15-20C	1.500 (38.10)	.375 (9.53)	.188 (4.78)	2.0 (51)
	Finishing	-	IFR15-20C	1.500 (38.10)	.375 (9.53)	.188 (4.78)	2.0 (51)
	Thread Mill	32UN-14UN** 0.75mm-1.75mm** 28BSP-14BSP	ITR15-1.5MMB-20C	1.500 (38.10)	.375 (9.53)	.188 (4.78)	2.0 (51)
		13UN-8UN** 2.0mm-3.5mm** 11BSP	ITR15-12B-20C	1.600 (40.64)	.425 (10.80)	.188 (4.78)	2.0 (51)
7UN-4UN** 4.0mm-6.0mm** all NPT, NPTF & BSPT	ITR15-4.0MMB-20C	1.700 (43.18)	.475 (12.07)	.188 (4.78)	2.0 (51)		
ITR15-8NPT-15C	1.700 (43.18)	.475 (12.07)	.188 (4.78)	1.5 (38)			
RM175-125-F6 RM175-32MM-F6 RM175-C50-F6-5 RM175-C50-F6-6 RM175-C50-F6-7	Roughing	-	IRR175-20C	1.750 (44.45)	.375 (9.53)	.188 (4.78)	2.0 (51)
	Semi-Finishing	-	ISR175-20C	1.750 (44.45)	.375 (9.53)	.188 (4.78)	2.0 (51)
	Finishing	-	IFR175-20C	1.750 (44.45)	.375 (9.53)	.188 (4.78)	2.0 (51)
	Thread Mill	32UN-14UN** 0.75mm-1.75mm** 28BSP-14BSP	ITR175-14B-20C	1.750 (44.45)	.375 (9.53)	.188 (4.78)	2.0 (51)
		13UN-8UN** 2.0mm-3.5mm** 11BSP	ITR175-12B-20C	1.850 (46.99)	.425 (10.80)	.188 (4.78)	2.0 (51)
7UN-4UN** 4.0mm-6.0mm** all NPT, NPTF & BSPT	ITR175-4.0MMB-20C	1.950 (49.53)	.475 (12.07)	.188 (4.78)	2.0 (51)		
ITR175-8NPT-15C	1.950 (49.53)	.475 (12.07)	.188 (4.78)	1.5 (38)			

** Must specify internal (B) or external (A) for UN and Metric thread

*** Insert Number Designation -

- Insert Number: I T R 20-8B-30 - will cut internal threads

see **Quadmill Inserts Designation**

- Insert Number: I T R 20-8A-30 - will cut external threads

QUADMILL INSERTS



Dimensions in Inches (mm)

Part Number	Tool Style	Thread Form	Insert*** # Example	Tool Cutter Diameter (d)	Insert Height	Insert Thickness	Length of Cut (l)	
RM20-20-F6 RM20-50MM-F6 RM20-C50-F6-6 RM20-C50-F6-7 RM20-C50-F6-8	Roughing	-	IRR20-30C	2.000 (50.80)	.375 (9.53)	.188 (4.78)	3.0 (76)	
	Semi-Finishing	-	ISR20-30C	2.000 (50.80)	.375 (9.53)	.188 (4.78)	3.0 (76)	
	Finishing	-	IFR20-30C	2.000 (50.80)	.375 (9.53)	.188 (4.78)	3.0 (76)	
	Thread Mill		32UN-14UN** 0.75mm-1.75mm**	ITR20-14A-30C ITR20-1.5MMA-30C	2.000 (50.80)	.375 (9.53)	.188 (4.78)	3.0 (76)
			28BSP-14BSP	ITR20-14bsp-30				
			13UN-8UN** 2.0mm-3.5mm** 11BSP	ITR20-12B-30C	2.100 (53.34)	.425 (10.80)	.188 (4.78)	3.0 (76)
			7UN-4UN** 4.0mm-6.0mm**	ITR20-7B-30C	2.200 (55.88)	.475 (12.07)	.188 (4.78)	3.0 (76)
		all NPT, NPTF & BSPT	ITR20-8NPTF-15C	2.200 (55.88)	.475 (12.07)	.188 (4.78)	1.5 (38)	
RM30-20-F10 RM30-50MM-F10 RM30-C50-F10-6 RM30-C50-F10-7 RM30-C50-F10-8	Roughing	-	IRR30-30C	3.000 (76.20)	.375 (9.53)	.188 (4.78)	3.0 (76)	
	Semi-Finishing	-	ISR30-30C	3.000 (76.20)	.375 (9.53)	.188 (4.78)	3.0 (76)	
	Finishing	-	IFR30-30C	3.000 (76.20)	.375 (9.53)	.188 (4.78)	3.0 (76)	
	Thread Mill		32UN-14UN** 0.75mm-1.75mm**	ITR30-14BSP-30	3.000 (76.20)	.375 (9.53)	.188 (4.78)	3.0 (76)
			28BSP-14BSP					
			13UN-8UN** 2.0mm-3.5mm** 11BSP	ITR30-12B-30C	3.100 (78.74)	.425 (10.80)	.188 (4.78)	3.0 (76)
			7UN-4UN** 4.0mm-6.0mm**	ITR30-4.0MMB-30C	3.200 (81.28)	.475 (12.07)	.188 (4.78)	3.0 (76)
		all NPT, NPTF & BSPT	ITR30-8NPT-15C	3.200 (81.28)	.475 (12.07)	.188 (4.78)	1.5 (38)	
RM40-20-F14 RM40-50MM-F14 RM40-C50-F14-6 RM40-C50-F14-7 RM40-C50-F14-8	Roughing	-	IRR40-30C	4.000 (101.6)	.375 (9.53)	.188 (4.78)	3.0 (76)	
	Semi-Finishing	-	ISR40-30C	4.000 (101.6)	.375 (9.53)	.188 (4.78)	3.0 (76)	
	Finishing	-	IFR40-30C	4.000 (101.6)	.375 (9.53)	.188 (4.78)	3.0 (76)	
	Thread Mill		32UN-14UN** 0.75mm-1.75mm**	ITR40-1.5MMA-30C	4.000 (101.6)	.375 (9.53)	.188 (4.78)	3.0 (76)
			28BSP-14BSP					
			13UN-8UN** 2.0mm-3.5mm** 11BSP	ITR40-12B-30C	4.100 (104.14)	.425 (10.80)	.188 (4.78)	3.0 (76)
			7UN-4UN** 4.0mm-6.0mm**	ITR40-4.0MMB-30	4.200 (106.68)	.475 (12.07)	.188 (4.78)	3.0 (76)
		all NPT, NPTF & BSPT	ITR40-8NPTF-15	4.200 (106.68)	.475 (12.07)	.188 (4.78)	1.5 (38)	

** Must specify internal (B) or external (A) for UN and Metric thread

- **Insert Number:** I T R 20-8B-30 - will cut internal threads

- **Insert Number:** I T R 20-8A-30 - will cut external threads

* See Page 39 for Insert Designation

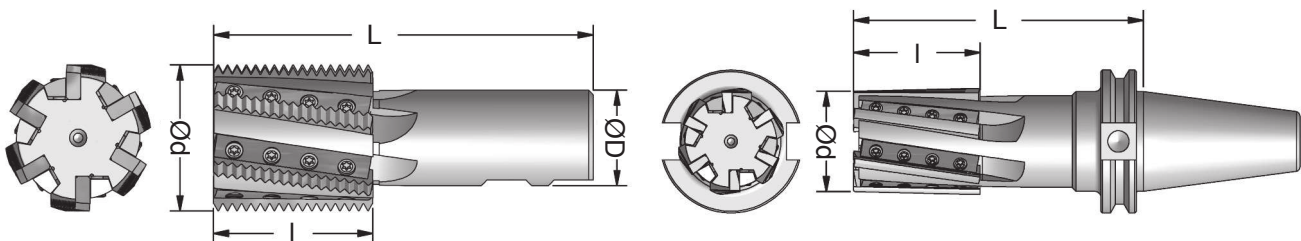

SOLID CARBIDE THREADMILL DESIGNATION



Column 1: Minimum Size Thread

04 = No.4 - 0.112" (0440316-40 Pitch Tool)
06 = No.6 - 0.138" (0632316-32 Pitch Tool)
08 = No.8 - 0.164" (0832316-32 Pitch Tool)
10 = No.10 - 0.190" (1024316-24 Pitch Tool)
12 = No.12 - 0.216" (1224316-24 Pitch Tool)
14 = 1/4" - 0.250"
516 = 5/16" - 0.3125"
38 = 3/8" - 0.375"
716 = 7/16" - 0.4375"
12 = 1/2" - 0.500" (121338-13 Pitch Tool)
916 = 9/16" - 0.5625"
58 = 5/8" - 0.625"
1116 = 11/16" - 0.6875"
34 = 3/4" - 0.750"
78 = 7/8" - 0.875"
01 = 1" - 1.000"

M6 = 6.0mm (Shank Diameter is in Inch Sizes)
M30 = 30.0mm (Shank Diameter is in Inch Sizes)
EM6 = 6.0mm (Shank Diameter is in MM Sizes)
EM30 = 30.0mm (Shank Diameter is in MM Sizes)

Column 2: Threads per Inch (Pitch in mm - Metric Tools)

Column 3: Shank Size

316 = Shank \varnothing 0.1875"
14 = Shank \varnothing 0.250"
516 = Shank \varnothing 0.3125"
38 = Shank \varnothing 0.375"
12 = Shank \varnothing 0.500"
58 = Shank \varnothing 0.625"
34 = Shank \varnothing 0.750"
01 = Shank \varnothing 1.000"

Metric Shank Thread Mills (EM)

06 = Shank \varnothing 6.0mm
08 = Shank \varnothing 8.0mm
10 = Shank \varnothing 10.0mm
12 = Shank \varnothing 12.0mm
16 = Shank \varnothing 16.0mm
20 = Shank \varnothing 20.0mm
25 = Shank \varnothing 25.0mm

Column 4: Tool Style Description

1CS = Solid Carbide Straight UN or MM Thread Form, 4 Flutes
1CSF6 = Solid Carbide Straight UN or MM Thread Form, 6 Flutes
1CSNPT = Solid Carbide Straight NPT Thread Form, 4 Flutes
1CSNPTF6 = Solid Carbide Straight NPT Thread Form, 6 Flutes
1CSNPTF = Solid Carbide Straight NPTF Thread Form, 4 Flutes
1CSNPTFF6 = Solid Carbide Straight NPTF Thread Form, 6 Flutes
1CSNPSF = Solid Carbide Straight NPSF Thread Form, 4 Flutes
1CSBSP = Solid Carbide Straight BSP Thread Form, 4 Flutes
1CSBSPT = Solid Carbide Straight BSPT Thread Form, 4 Flutes
1CSF3BH = Solid Carbide Helical UN or MM Internal Thread Form, 3 Flutes
1CSF3AH = Solid Carbide Helical UN or MM External Thread Form, 3 Flutes
1CSBH = Solid Carbide Helical UN or MM Internal Thread Form, 4 Flutes
1CSAH = Solid Carbide Helical UN or MM External Thread Form, 4 Flutes
1CSNPTH = Solid Carbide Helical NPT Thread Form, 4 Flutes
1CSBSPH = Solid Carbide Helical BSP Thread Form, 4 Flutes
1CSBSPTH = Solid Carbide Helical BSPT Thread Form, 4 Flutes
BH3KL -- = Solid Carbide 30° Helical UN Thread Form; 4, 5, and 6 Flutes; K - Coolant Thru; L - Length of Cut

Column 5: Coating

" " = Uncoated
C = TiN - (Titanium Nitride)
Y = TiCN - (Titanium Carbonitride)
Z = TiAlN (Titanium Aluminum Nitride)
V = Hardmill (Aluminum Titanium Nitride)
X = ZrN (Zirconium Nitride)

For Coating Descriptions - See Page 17

SOLID CARBIDE STRAIGHT FLUTE THREAD MILLS



Unified (UN) Threads

UNIFIED (UN) THREADS

Dimensions in Inches (mm)

Minimum Size	Tool Number	Pitch	Cutter Diameter (d)	Length of Cut (l)	Number of Flutes	Length (L)	Shank Diameter (D)	Coatings Available		
								Uncoated	Z TiAlN	V Hardmill
#4-40	0440316-1CS	40	0.080	0.100	4	2.5	0.188	O	X	O
#6-32	0632316-1CS	32	0.100	0.200	4	2.5	0.188	O	X	O
#8-32	0832316-1CS	32	0.120	0.200	4	2.5	0.188	O	X	O
#10-24	1024316-1CS	24	0.140	0.250	4	2.5	0.188	O	X	O
#10-32	1032316-1CS	32	0.140	0.250	4	2.5	0.188	O	X	O
#12-24	1224316-1CS	24	0.160	0.350	4	2.5	0.188	O	X	O
#12-28	1228316-1CS	28	0.160	0.350	4	2.5	0.188	O	X	O
1/4"-20	142014-1CS	20	0.190	0.400	4	3.0	0.250	O	X	O
1/4"-24	142414-1CS	24	0.190	0.400	4	3.0	0.250	O	O	O
1/4"-27	142714-1CS	27	0.190	0.400	4	3.0	0.250	O	O	O
1/4"-28	142814-1CS	28	0.190	0.400	4	3.0	0.250	O	X	O
1/4"-32	143214-1CS	32	0.190	0.400	4	3.0	0.250	O	X	O
1/4"-36	143614-1CS	36	0.190	0.400	4	3.0	0.250	O	O	O
1/4"-40	144014-1CS	40	0.190	0.400	4	3.0	0.250	O	O	O
1/4"-48	144814-1CS*	48	0.190	0.400	4	3.0	0.250	O	O	O
1/4"-56	145614-1CS*	56	0.190	0.400	4	3.0	0.250	O	O	O
5/16"-16	5161614-1CS	16	0.245	0.625	4	3.0	0.250	O	O	O
5/16"-18	5161814-1CS	18	0.245	0.625	4	3.0	0.250	O	X	O
5/16"-20	5162014-1CS	20	0.245	0.625	4	3.0	0.250	O	O	O
5/16"-24	5162414-1CS	24	0.245	0.625	4	3.0	0.250	O	X	O
5/16"-27	5162714-1CS	27	0.245	0.625	4	3.0	0.250	O	O	O
5/16"-28	5162814-1CS	28	0.245	0.625	4	3.0	0.250	O	O	O
5/16"-32	5163214-1CS	32	0.245	0.625	4	3.0	0.250	O	X	O
5/16"-36	5163614-1CS	36	0.245	0.625	4	3.0	0.250	O	O	O
5/16"-40	5164014-1CS	40	0.245	0.625	4	3.0	0.250	O	O	O
5/16"-48	5164814-1CS*	48	0.245	0.625	4	3.0	0.250	O	O	O
3/8"-16	3816516-1CS	16	0.300	0.750	4	3.0	0.312	O	X	O
3/8"-18	3818516-1CS	18	0.300	0.750	4	3.0	0.312	O	O	O
3/8"-20	3820516-1CS	20	0.300	0.750	4	3.0	0.312	O	O	O
3/8"-24	3824516-1CS	24	0.300	0.750	4	3.0	0.312	O	X	O
3/8"-27	3827516-1CS	27	0.300	0.750	4	3.0	0.312	O	O	O
3/8"-28	3828516-1CS	28	0.300	0.750	4	3.0	0.312	O	O	O
3/8"-32	3832516-1CS	32	0.300	0.750	4	3.0	0.312	O	X	O
3/8"-36	3836516-1CS	36	0.300	0.750	4	3.0	0.312	O	O	O
3/8"-40	3840516-1CS	40	0.300	0.750	4	3.0	0.312	O	O	O
7/16"-14	7161438-1CS	14	0.350	0.750	4	3.0	0.375	O	X	O
7/16"-16	7161638-1CS	16	0.350	0.750	4	3.0	0.375	O	O	O
7/16"-18	7161838-1CS	18	0.350	0.750	4	3.0	0.375	O	O	O
7/16"-20	7162038-1CS	20	0.350	0.750	4	3.0	0.375	O	X	O
7/16"-24	7162438-1CS	24	0.350	0.750	4	3.0	0.375	O	O	O
7/16"-27	7162738-1CS	27	0.350	0.750	4	3.0	0.375	O	O	O
7/16"-28	7162838-1CS	28	0.350	0.750	4	3.0	0.375	O	X	O
7/16"-32	7163238-1CS	32	0.350	0.750	4	3.0	0.375	O	O	O
1/2"-12	121238-1CS	12	0.370	0.750	4	3.0	0.375	O	O	O
1/2"-13	121338-1CS	13	0.370	0.750	4	3.0	0.375	O	X	O
1/2"-14	121438-1CS	14	0.370	0.750	4	3.0	0.375	O	O	O
1/2"-16	121638-1CS	16	0.370	0.750	4	3.0	0.375	O	O	O
1/2"-18	121838-1CS	18	0.370	0.750	4	3.0	0.375	O	O	O

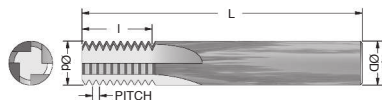

X = In Stock ; O = Special Order ; Other Coatings Available ; Call for Delivery
Other Sizes Available Upon Request - Tools will cut internal & external thread
*Designates Staggered Thread

SOLID CARBIDE STRAIGHT FLUTE THREAD MILLS



Unified (UN) Threads

UNIFIED (UN) THREADS

Dimensions in Inches (mm)

Minimum Size	Tool Number	Pitch	Cutter Diameter (d)	Length of Cut (l)	Number of Flutes	Length (L)	Shank Diameter (D)	Coatings Available		
								Uncoated	Z TiAlN	V Hardmill
1/2"-20	122038-1CS	20	0.370	0.750	4	3.0	0.375	O	X	O
1/2"-24	122438-1CS	24	0.370	0.750	4	3.0	0.375	O	O	O
1/2"-27	122738-1CS	27	0.370	0.750	4	3.0	0.375	O	O	O
1/2"-28	122838-1CS	28	0.370	0.750	4	3.0	0.375	O	X	O
1/2"-32	123238-1CS	32	0.370	0.750	4	3.0	0.375	O	O	O
9/16"-12	9161212-1CS	12	0.430	0.750	4	4.0	0.500	O	X	O
9/16"-14	9161412-1CS	14	0.450	0.750	4	4.0	0.500	O	O	O
9/16"-16	9161612-1CS	16	0.450	0.750	4	4.0	0.500	O	O	O
9/16"-18	9161812-1CS	18	0.450	0.750	4	4.0	0.500	O	X	O
9/16"-20	9162012-1CS	20	0.450	0.750	4	4.0	0.500	O	O	O
9/16"-24	9162412-1CS	24	0.450	0.750	4	4.0	0.500	O	X	O
9/16"-27	9162712-1CS	27	0.450	0.750	4	4.0	0.500	O	O	O
9/16"-28	9162812-1CS	28	0.450	0.750	4	4.0	0.500	O	O	O
9/16"-32	9163212-1CS	32	0.450	0.750	4	4.0	0.500	O	O	O
5/8"-11	581112-1CS	11	0.430	1.000	4	4.0	0.500	O	X	O
5/8"-11	581112-1CSF6	11	0.430	1.000	6	4.0	0.500	O	O	O
5/8"-12	581212-1CS	12	0.430	1.000	4	4.0	0.500	O	O	O
5/8"-12	581212-1CSF6	12	0.430	1.000	6	4.0	0.500	O	O	O
5/8"-14	581412-1CS	14	0.495	1.000	4	4.0	0.500	O	O	O
5/8"-14	581412-1CSF6	14	0.495	1.000	6	4.0	0.500	O	O	O
5/8"-16	581612-1CS	16	0.495	1.000	4	4.0	0.500	O	X	O
5/8"-16	581612-1CSF6	16	0.495	1.000	6	4.0	0.500	O	O	O
5/8"-18	581812-1CS	18	0.495	1.000	4	4.0	0.500	O	X	O
5/8"-18	581812-1CSF6	18	0.495	1.000	6	4.0	0.500	O	O	O
5/8"-20	582012-1CS	20	0.495	1.000	4	4.0	0.500	O	O	O
5/8"-20	582012-1CSF6	20	0.495	1.000	6	4.0	0.500	O	O	O
5/8"-24	582412-1CS	24	0.495	1.000	4	4.0	0.500	O	X	O
5/8"-24	582412-1CSF6	24	0.495	1.000	6	4.0	0.500	O	O	O
5/8"-27	582712-1CS	27	0.495	1.000	4	4.0	0.500	O	O	O
5/8"-27	582712-1CSF6	27	0.495	1.000	6	4.0	0.500	O	O	O
5/8"-28	582812-1CS	28	0.495	1.000	4	4.0	0.500	O	O	O
5/8"-28	582812-1CSF6	28	0.495	1.000	6	4.0	0.500	O	O	O
5/8"-32	583212-1CS	32	0.495	1.000	4	4.0	0.500	O	O	O
5/8"-32	583212-1CSF6	32	0.495	1.000	6	4.0	0.500	O	O	O
3/4"-10	341058-1CS	10	0.620	1.000	4	4.0	0.625	O	X	O
3/4"-10	341058-1CSF6	10	0.620	1.000	6	4.0	0.625	O	O	O
3/4"-12	341258-1CS	12	0.620	1.000	4	4.0	0.625	O	O	O
3/4"-12	341258-1CSF6	12	0.620	1.000	6	4.0	0.625	O	O	O
3/4"-14	341458-1CS	14	0.620	1.000	4	4.0	0.625	O	O	O
3/4"-14	341458-1CSF6	14	0.620	1.000	6	4.0	0.625	O	O	O
3/4"-16	341658-1CS	16	0.620	1.000	4	4.0	0.625	O	X	O
3/4"-16	341658-1CSF6	16	0.620	1.000	6	4.0	0.625	O	O	O
3/4"-18	341858-1CS	18	0.620	1.000	4	4.0	0.625	O	O	O
3/4"-18	341858-1CSF6	18	0.620	1.000	6	4.0	0.625	O	O	O
3/4"-20	342058-1CS	20	0.620	1.000	4	4.0	0.625	O	X	O
3/4"-20	342058-1CSF6	20	0.620	1.000	6	4.0	0.625	O	O	O

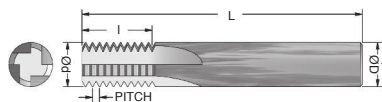

X = In Stock ; O = Special Order ; Other Coatings Available ; Call for Delivery
Other Sizes Available Upon Request - Tools will cut internal & external thread
*Designates Staggered Thread

SOLID CARBIDE STRAIGHT FLUTE THREAD MILLS



Unified (UN) Threads

UNIFIED (UN) THREADS

Dimensions in Inches (mm)

Minimum Size	Tool Number	Pitch	Cutter Diameter (d)	Length of Cut (l)	Number of Flutes	Length (L)	Shank Diameter (D)	Coatings Available		
								Uncoated	Z TiAlN	V Hardmill
3/4"-24	342458-1CS	24	0.620	1.000	4	4.0	0.625	O	O	O
3/4"-24	342458-1CSF6	24	0.620	1.000	6	4.0	0.625	O	O	O
3/4"-27	342758-1CS	27	0.620	1.000	4	4.0	0.625	O	O	O
3/4"-27	342758-1CSF6	27	0.620	1.000	6	4.0	0.625	O	O	O
3/4"-28	342858-1CS	28	0.620	1.000	4	4.0	0.625	O	O	O
3/4"-28	342858-1CSF6	28	0.620	1.000	6	4.0	0.625	O	O	O
3/4"-32	343258-1CS	32	0.620	1.000	4	4.0	0.625	O	O	O
3/4"-32	343258-1CSF6	32	0.620	1.000	6	4.0	0.625	O	O	O
7/8"-9	780934-1CS	9	0.745	1.250	4	4.0	0.750	O	X	O
7/8"-9	780934-1CSF6	9	0.745	1.250	6	4.0	0.750	O	O	O
7/8"-10	781034-1CS	10	0.745	1.250	4	4.0	0.750	O	O	O
7/8"-10	781034-1CSF6	10	0.745	1.250	6	4.0	0.750	O	O	O
7/8"-12	781234-1CS	12	0.745	1.250	4	4.0	0.750	O	O	O
7/8"-12	781234-1CSF6	12	0.745	1.250	6	4.0	0.750	O	O	O
7/8"-14	781434-1CS	14	0.745	1.250	4	4.0	0.750	O	X	O
7/8"-14	781434-1CSF6	14	0.745	1.250	6	4.0	0.750	O	O	O
7/8"-16	781634-1CS	16	0.745	1.250	4	4.0	0.750	O	O	O
7/8"-16	781634-1CSF6	16	0.745	1.250	6	4.0	0.750	O	O	O
7/8"-18	781834-1CS	18	0.745	1.250	4	4.0	0.750	O	O	O
7/8"-18	781834-1CSF6	18	0.745	1.250	6	4.0	0.750	O	O	O
7/8"-20	782034-1CS	20	0.745	1.250	4	4.0	0.750	O	X	O
7/8"-20	782034-1CSF6	20	0.745	1.250	6	4.0	0.750	O	O	O
7/8"-24	782434-1CS	24	0.745	1.250	4	4.0	0.750	O	O	O
7/8"-24	782434-1CSF6	24	0.745	1.250	6	4.0	0.750	O	O	O
7/8"-27	782734-1CS	27	0.745	1.250	4	4.0	0.750	O	O	O
7/8"-27	782734-1CSF6	27	0.745	1.250	6	4.0	0.750	O	O	O
7/8"-28	782834-1CS	28	0.745	1.250	4	4.0	0.750	O	O	O
7/8"-28	782834-1CSF6	28	0.745	1.250	6	4.0	0.750	O	O	O
7/8"-32	783234-1CS	32	0.745	1.250	4	4.0	0.750	O	O	O
7/8"-32	783234-1CSF6	32	0.745	1.250	6	4.0	0.750	O	O	O
1"-8	010834-1CS	8	0.745	1.250	4	4.0	0.750	O	X	O
1"-8	010834-1CSF6	8	0.745	1.250	6	4.0	0.750	O	O	O
1-1/8"-7	010734-1CS	7	0.745	1.250	4	4.0	0.750	O	X	O
1-1/8"-7	010734-1CSF6	7	0.745	1.250	6	4.0	0.750	O	O	O

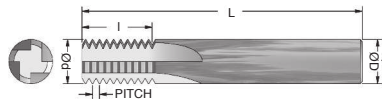

X = In Stock ; O = Special Order ; Other Coatings Available ; Call for Delivery
Other Sizes Available Upon Request - Tools will cut internal & external thread
*Designates Staggered Thread

SOLID CARBIDE STRAIGHT FLUTE METRIC THREAD MILLS



Metric (M) Threads

METRIC (M) THREADS

Dimensions in Inches (mm)

Minimum Size	Tool Number	Pitch	Cutter Diameter (d)	Length of Cut (l)	Number of Flutes	Length (L)	Shank Diameter (D)	Coatings Available		
								Uncoated	Z TiAlN	V Hardmill
M4x0.7	M40.7316-1CS	0.70	0.110	0.200	4	2.5	0.188	O	X	O
M5x0.8	M50.8316-1CS	0.80	0.140	0.250	4	2.5	0.188	O	X	O
M6x1.0	M61.014-1CS	1.00	0.169	0.400	4	3.0	0.250	O	X	O
M6x0.75	M60.7514-1CS	0.75	0.169	0.400	4	3.0	0.250	O	O	O
M8x1.25	M81.2514-1CS	1.25	0.232	0.625	4	3.0	0.250	O	X	O
M8x1.0	M81.014-1CS	1.00	0.232	0.625	4	3.0	0.250	O	X	O
M8x0.75	M80.7514-1CS	0.75	0.232	0.625	4	3.0	0.250	O	O	O
M10x1.5	M101.5516-1CS	1.50	0.287	0.750	4	3.0	0.312	O	X	O
M10x1.25	M101.25516-1CS	1.25	0.287	0.750	4	3.0	0.312	O	X	O
M10x1.0	M101.0516-1CS	1.00	0.287	0.750	4	3.0	0.312	O	O	O
M10x0.75	M100.75516-1CS	0.75	0.287	0.750	4	3.0	0.312	O	O	O
M12x1.75	M121.7538-1CS	1.75	0.370	0.750	4	3.0	0.375	O	X	O
M12x1.5	M121.538-1CS	1.50	0.370	0.750	4	3.0	0.375	O	O	O
M12x1.25	M121.2538-1CS	1.25	0.370	0.750	4	3.0	0.375	O	X	O
M12x1.0	M121.038-1CS	1.00	0.370	0.750	4	3.0	0.375	O	O	O
M14x2.0	M142.012-1CS	2.00	0.429	1.000	4	4.0	0.500	O	X	O
M14x2.0	M142.012-1CSF6	2.00	0.429	1.000	6	4.0	0.500	O	O	O
M14x1.5	M141.512-1CS	1.50	0.429	1.000	4	4.0	0.500	O	X	O
M14x1.5	M141.512-1CSF6	1.50	0.429	1.000	6	4.0	0.500	O	O	O
M14x1.25	M141.2512-1CS	1.25	0.429	1.000	4	4.0	0.500	O	O	O
M14x1.25	M141.2512-1CSF6	1.25	0.429	1.000	6	4.0	0.500	O	O	O
M14x1.0	M141.012-1CS	1.00	0.429	1.000	4	4.0	0.500	O	O	O
M14x1.0	M141.012-1CSF6	1.00	0.429	1.000	6	4.0	0.500	O	O	O
M18x2.5	M182.512-1CS	2.50	0.495	1.000	4	4.0	0.500	O	X	O
M18x2.5	M182.512-1CSF6	2.50	0.495	1.000	6	4.0	0.500	O	O	O
M18x2.0	M182.012-1CS	2.00	0.495	1.000	4	4.0	0.500	O	O	O
M18x2.0	M182.012-1CSF6	2.00	0.495	1.000	6	4.0	0.500	O	O	O
M18x1.5	M181.512-1CS	1.50	0.495	1.000	4	4.0	0.500	O	X	O
M18x1.5	M181.512-1CSF6	1.50	0.495	1.000	6	4.0	0.500	O	O	O
M18x1.0	M181.012-1CS	1.00	0.495	1.000	4	4.0	0.500	O	O	O
M18x1.0	M181.012-1CSF6	1.00	0.495	1.000	6	4.0	0.500	O	O	O
M22x2.5	M222.558-1CS	2.50	0.620	1.000	4	4.0	0.625	O	X	O
M22x2.5	M222.558-1CSF6	2.50	0.620	1.000	6	4.0	0.625	O	O	O
M22x2.0	M222.058-1CS	2.00	0.620	1.000	4	4.0	0.625	O	X	O
M22x2.0	M222.058-1CSF6	2.00	0.620	1.000	6	4.0	0.625	O	O	O
M22x1.5	M221.558-1CS	1.50	0.620	1.000	4	4.0	0.625	O	X	O
M22x1.5	M221.558-1CSF6	1.50	0.620	1.000	6	4.0	0.625	O	O	O
M22x1.0	M221.058-1CS	1.00	0.620	1.000	4	4.0	0.625	O	O	O
M22x1.0	M221.058-1CSF6	1.00	0.620	1.000	6	4.0	0.625	O	O	O
M24x3.0	M243.058-1CS	3.00	0.620	1.000	4	4.0	0.625	O	X	O
M24x3.0	M243.058-1CSF6	3.00	0.620	1.000	6	4.0	0.625	O	O	O
M30x3.5	M303.534-1CS	3.50	0.745	1.250	4	4.0	0.750	O	X	O
M30x3.5	M303.534-1CSF6	3.50	0.745	1.250	6	4.0	0.750	O	O	O
M36x4.0	M364.034-1CS	4.00	0.745	1.250	4	4.0	0.750	O	X	O
M36x4.0	M364.034-1CSF6	4.00	0.745	1.250	6	4.0	0.750	O	O	O

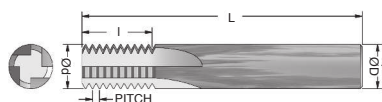

X = In Stock ; O = Special Order ; Other Coatings Available ; Call for Delivery
Other Sizes Available Upon Request - Tools will cut internal & external thread
*Designates Staggered Thread

SOLID CARBIDE STRAIGHT FLUTE THREAD MILLS



National Taper Pipe (NPT) Threads

NATIONAL TAPER PIPE (NPT) THREADS

Dimensions in Inches (mm)

Minimum Size	Tool Number	Pitch	Cutter Diameter (d)	Length of Cut (l)	Number of Flutes	Length (L)	Shank Diameter (D)	Coatings Available		
								Uncoated	Z TiAIN	V Hardmill
1/16"-27	142714-1CSNPTD190	27	0.190	0.400	4	3.0	0.250	O	X	O
1/8"-27	142714-1CSNPT	27	0.240	0.625	4	3.0	0.250	O	X	O
1/8"-27	51627516-1CSNPT	27	0.308	0.741	4	3.0	0.312	O	X	O
1/8"-27	5162738-1CSNPT	27	0.308	0.741	4	3.0	0.375	O	O	O
1/4"-18	381838-1CSNPT	18	0.370	0.778	4	3.0	0.375	O	X	O
1/4"-18	7161812-1CSNPT	18	0.432	0.778	4	4.0	0.500	O	O	O
1/2"-14	121412-1CSNPT	14	0.495	1.000	4	4.0	0.500	O	X	O
1/2"-14	121412-1CSNPTF6	14	0.495	1.000	6	4.0	0.500	O	O	O
1/2"-14	581458-1CSNPT	14	0.620	1.000	4	4.0	0.625	O	X	O
1/2"-14	581458-1CSNPTF6	14	0.620	1.000	6	4.0	0.625	O	O	O
1"-11.5	5811558-1CSNPT	11.5	0.620	1.044	4	4.0	0.625	O	X	O
1"-11.5	5811558-1CSNPTF6	11.5	0.620	1.044	6	4.0	0.625	O	O	O
1"-11.5	3411534-1CSNPT	11.5	0.745	1.044	4	4.0	0.750	O	X	O
1"-11.5	3411534-1CSNPTF6	11.5	0.745	1.044	6	4.0	0.750	O	O	O
2-1/2"-8	340834-1CSNPT	8	0.745	1.125	4	4.0	0.750	O	X	O
2-1/2"-8	340834-1CSNPTF6	8	0.745	1.125	6	4.0	0.750	O	O	O

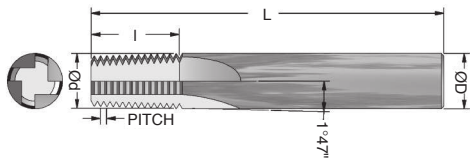

X = In Stock ; O = Special Order ; Other Coatings Available ; Call for Delivery
Other Sizes Available Upon Request - Tools will cut internal & external thread
*Designates Staggered Thread

SOLID CARBIDE STRAIGHT FLUTE THREAD MILLS

Dryseal Taper Pipe (NPTF) Threads

DRYSEAL TAPER PIPE (NPTF) THREADS

Dimensions in Inches (mm)

Minimum Size	Tool Number	Pitch	Cutter Diameter (d)	Length of Cut (l)	Number of Flutes	Length (L)	Shank Diameter (D)	Coatings Available		
								Uncoated	Z TiAlN	V Hardmill
1/16"-27	142714-1CSNPTFD190	27	0.190	0.400	4	3.0	0.250	O	X	O
1/8"-27	142714-1CSNPTF	27	0.240	0.625	4	3.0	0.250	O	X	O
1/8"-27	51627516-1CSNPTF	27	0.308	0.741	4	3.0	0.312	O	X	O
1/8"-27	5162738-1CSNPTF	27	0.308	0.741	4	3.0	0.375	O	O	O
1/4"-18	381838-1CSNPTF	18	0.370	0.778	4	3.0	0.375	O	X	O
1/4"-18	7161812-1CSNPTF	18	0.432	0.778	4	4.0	0.500	O	O	O
1/2"-14	121412-1CSNPTF	14	0.495	1.000	4	4.0	0.500	O	X	O
1/2"-14	121412-1CSNPTFF6	14	0.495	1.000	6	4.0	0.500	O	O	O
1/2"-14	581458-1CSNPTF	14	0.620	1.000	4	4.0	0.625	O	X	O
1/2"-14	581458-1CSNPTFF6	14	0.620	1.000	6	4.0	0.625	O	O	O
1"-11.5	5811558-1CSNPTF	11.5	0.620	1.044	4	4.0	0.625	O	X	O
1"-11.5	5811558-1CSNPTFF6	11.5	0.620	1.044	6	4.0	0.625	O	O	O
1"-11.5	3411534-1CSNPTF	11.5	0.745	1.044	4	4.0	0.750	O	X	O
1"-11.5	3411534-1CSNPTFF6	11.5	0.745	1.044	6	4.0	0.750	O	O	O
2-1/2"-8	340834-1CSNPTF	8	0.745	1.125	4	4.0	0.750	O	X	O
2-1/2"-8	340834-1CSNPTFF6	8	0.745	1.125	6	4.0	0.750	O	O	O

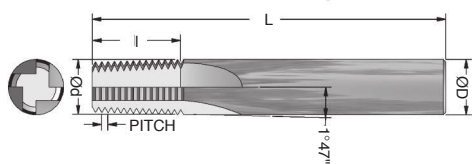

X = In Stock ; O = Special Order ; Other Coatings Available ; Call for Delivery
Other Sizes Available Upon Request - Tools will cut internal & external thread
*Designates Staggered Thread

SOLID CARBIDE STRAIGHT FLUTE THREAD MILLS

Dryseal Straight Pipe (NPSF) Threads

DRYSEAL STRAIGHT PIPE (NPSF) THREADS

Dimensions in Inches (mm)

Minimum Size	Tool Number	Pitch	Cutter Diameter (d)	Length of Cut (l)	Number of Flutes	Length (L)	Shank Diameter (D)	Coatings Available		
								Uncoated	Z TiAlN	V Hardmill
1/16"-27	142714-1CSNPSFD190	27	0.190	0.400	4	3.0	0.250	O	O	O
1/8"-27	142714-1CSNPSF	27	0.240	0.625	4	3.0	0.250	O	O	O
1/8"-27	51627516-1CSNPSF	27	0.300	0.741	4	3.0	0.312	O	O	O
1/4"-18	381838-1CSNPSF	18	0.370	0.778	4	3.0	0.375	O	O	O
1/2"-14	581458-1CSNPSF	14	0.620	1.000	4	4.0	0.625	O	O	O
1/2"-14	581458-1CSNPSFF6	14	0.620	1.000	6	4.0	0.625	O	O	O
1"-11.5	5811558-1CSNPSF	11.5	0.620	1.000	4	4.0	0.625	O	O	O
1"-11.5	3411534-1CSNPSF	11.5	0.745	1.304	4	4.0	0.750	O	O	O
2-1/2"-8	340834-1CSNPSF	8	0.745	1.250	4	4.0	0.750	O	O	O

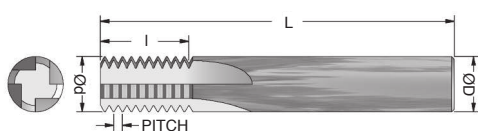

X = In Stock ; O = Special Order ; Other Coatings Available ; Call for Delivery
Other Sizes Available Upon Request - Tools will cut internal & external thread
*Designates Staggered Thread

SOLID CARBIDE STRAIGHT FLUTE THREAD MILLS

British Standard Parallel Pipe (BSPP)

BRITISH STANDARD PARALLEL PIPE (BSPP) THREADS

Dimensions in Inches (mm)

Minimum Size	Tool Number	Pitch	Cutter Diameter (d)	Length of Cut (l)	Number of Flutes	Length (L)	Shank Diameter (D)	Coatings Available		
								Uncoated	Z TiAlN	V Hardmill
1/8"-28	1828516-1CSBSP	28	0.300	0.750	4	3.0	0.312	○	○	○
1/4"-19	141938-1CSBSP	19	0.370	0.789	4	3.0	0.375	○	○	○
1/2"-14	121458-1CSBSP	14	0.620	1.000	4	4.0	0.625	○	○	○
1/2"-14	121458-1CSBSPF6	14	0.620	1.000	6	4.0	0.625	○	○	○
3/4"-14	341434-1CSBSP	14	0.745	1.286	4	4.0	0.750	○	○	○
3/4"-14	341434-1CSBSPF6	14	0.745	1.286	6	4.0	0.750	○	○	○
1"-11	011134-1CSBSP	11	0.745	1.272	4	4.0	0.750	○	○	○
1"-11	011134-1CSBSPF6	11	0.745	1.272	6	4.0	0.750	○	○	○

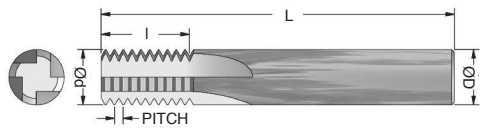

X = In Stock ; O = Special Order ; Other Coatings Available ; Call for Delivery
Other Sizes Available Upon Request - Tools will cut internal & external thread
*Designates Staggered Thread

SOLID CARBIDE STRAIGHT FLUTE THREAD MILLS

British Standard Parallel Pipe (BSPP) Threads, Metric Shank

BRITISH STANDARD PARALLEL PIPE (BSPP) THREADS, METRIC SHANK

Minimum Size	Tool Number	Pitch	Cutter Diameter (d)	Length of Cut (l)	Number of Flutes	Length (L)	Shank Diameter (D)	Coatings Available		
								Un-Coated	Z TiAlN	V Hardmill
1/8"-28	182808MM-1CSBSP	28	0.300 (7.6)	0.750 (19)	4	3.0 (76)	(8)	○	○	○
1/4"-19	141910MM-1CSBSP	19	0.390 (9.9)	0.789 (20)	4	3.0 (76)	(10)	○	○	○
1/2"-14	121416MM-1CSBSP	14	0.626 (15.9)	1.000 (25.4)	4	3.98 (101)	(16)	○	○	○
3/4"-14	341420MM-1CSBSP	14	0.783 (19.9)	1.286 (32.7)	4	4.0 (102)	(20)	○	○	○
1"-11	011120MM-1CSBSP	11	0.783 (19.9)	1.272 (32.3)	4	4.0 (102)	(20)	○	○	○

X = In Stock ; O = Special Order ; Other Coatings Available ; Call for Delivery
Other Sizes Available Upon Request - Tools will cut internal & external thread
*Designates Staggered Thread

SOLID CARBIDE STRAIGHT FLUTE THREAD MILLS

British Standard Pipe Taper (BSPT) Threads

BRITISH STANDARD PIPE TAPER (BSPT) THREADS

Dimensions in Inches (mm)

Minimum Size	Tool Number	Pitch	Cutter Diameter (d)	Length of Cut (l)	Number of Flutes	Length (L)	Shank Diameter (D)	Coatings Available		
								Un-Coated	Z TiAlN	V Hardmill
1/8"-28	1828516-1CSBSPT	28	0.300	0.750	4	3.0	0.312	○	○	○
1/4"-19	141938-1CSBSPT	19	0.370	0.789	4	3.0	0.375	○	○	○
1/2"-14	121458-1CSBSPT	14	0.620	1.000	4	4.0	0.625	○	○	○
1/2"-14	121458-1CSBSPTF6	14	0.620	1.000	6	4.0	0.625	○	○	○
3/4"-14	341434-1CSBSPT	14	0.745	1.286	4	4.0	0.750	○	○	○
3/4"-14	341434-1CSBSPTF6	14	0.745	1.286	6	4.0	0.750	○	○	○
1"-11	011134-1CSBSPT	11	0.745	1.272	4	4.0	0.750	○	○	○
1"-11	011134-1CSBSPTF6	11	0.745	1.272	6	4.0	0.750	○	○	○

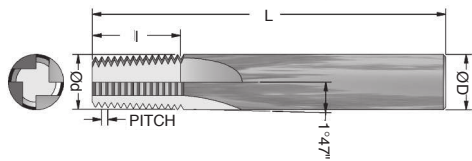

X = In Stock ; O = Special Order ; Other Coatings Available ; Call for Delivery
Other Sizes Available Upon Request - Tools will cut internal & external thread
*Designates Staggered Thread

SOLID CARBIDE STRAIGHT FLUTE THREAD MILLS

British Standard Pipe Taper (BSPT) Threads, Metric Shank

BRITISH STANDARD PIPE TAPER (BSPT) THREADS, METRIC SHANK

Minimum Size	Tool Number	Pitch	Cutter Diameter (d)	Length of Cut (l)	Number of Flutes	Length (L)	Shank Diameter (D)	Coatings Available		
								Un-Coated	Z TiAlN	V Hardmill
1/8"-28	182808MM-1CSBSPT	28	0.300 (7.6)	0.750 (19)	4	3.0 (76)	(8)	○	○	○
1/4"-19	141910MM-1CSBSPT	19	0.390 (9.9)	0.789 (20)	4	3.0 (76)	(10)	○	○	○
1/2"-14	121416MM-1CSBSPT	14	0.626 (15.9)	1.000 (25.4)	4	3.98 (101)	(16)	○	○	○
3/4"-14	341420MM-1CSBSPT	14	0.783 (19.9)	1.286 (32.7)	4	4.0 (102)	(20)	○	○	○
1"-11	011120MM-1CSBSPT	11	0.783 (19.9)	1.272 (32.3)	4	4.0 (102)	(20)	○	○	○

X = In Stock ; O = Special Order ; Other Coatings Available ; Call for Delivery
Other Sizes Available Upon Request - Tools will cut internal & external thread
*Designates Staggered Thread

SOLID CARBIDE HELICAL THREAD MILLS



Unified (UN) Internal and External Threads

Dimensions in Inches (mm)

UNIFIED (UN) INTERNAL THREADS

Minimum Size	Tool Number	Pitch	Cutter Diameter (d)	Length of Cut (l)	Number of Flutes	Length (L)	Shank Diameter (D)	Coatings Available		
								Uncoated	Z TiAlN	V Hardmill
1/4"-20	142014-1CSF3BH	20	0.190	0.400	3	3.0	0.250	O	X	O
1/4"-28	142814-1CSF3BH	28	0.190	0.393	3	3.0	0.250	O	X	O
5/16"-18	5161814-1CSF3BH	18	0.245	0.611	3	3.0	0.250	O	X	O
5/16"-24	5162414-1CSF3BH	24	0.245	0.625	3	3.0	0.250	O	X	O
3/8"-16	3816516-1CSF3BH	16	0.300	0.750	3	3.0	0.312	O	X	O
3/8"-24	3824516-1CSF3BH	24	0.300	0.750	3	3.0	0.312	O	X	O
7/16"-14	7161438-1CSF3BH	14	0.350	0.786	3	3.0	0.375	O	X	O
7/16"-20	7162038-1CSF3BH	20	0.350	0.750	3	3.0	0.375	O	X	O
1/2"-13	121338-1CSF3BH	13	0.370	0.769	3	3.0	0.375	O	X	O
1/2"-20	122038-1CSF3BH	20	0.370	0.750	3	3.0	0.375	O	X	O
9/16"-12	9161212-1CSBH	12	0.430	0.750	4	4.0	0.500	O	X	O
9/16"-18	9161812-1CSBH	18	0.450	0.778	4	4.0	0.500	O	X	O
5/8"-11	581112-1CSBH	11	0.430	1.000	4	4.0	0.500	O	X	O
5/8"-18	581812-1CSBH	18	0.495	1.000	4	4.0	0.500	O	X	O
3/4"-10	341058-1CSBH	10	0.620	1.000	4	4.0	0.625	O	X	O
3/4"-16	341658-1CSBH	16	0.620	1.000	4	4.0	0.625	O	X	O
7/8"-9	780934-1CSBH	9	0.745	1.333	4	4.0	0.750	O	X	O
7/8"-14	781434-1CSBH	14	0.745	1.286	4	4.0	0.750	O	X	O
1"-8	010834-1CSBH	8	0.745	1.250	4	4.0	0.750	O	X	O
1"-12	011234-1CSBH	12	0.745	1.250	4	4.0	0.750	O	X	O

UNIFIED (UN) EXTERNAL THREADS

Dimensions in Inches (mm)

1/4"-20	142014-1CSF3AH	20	0.190	0.400	3	3.0	0.250	O	O	O
1/4"-28	142814-1CSF3AH	28	0.190	0.393	3	3.0	0.250	O	O	O
5/16"-18	5161814-1CSF3AH	18	0.245	0.611	3	3.0	0.250	O	O	O
5/16"-24	5162414-1CSF3AH	24	0.245	0.625	3	3.0	0.250	O	O	O
3/8"-16	3816516-1CSF3AH	16	0.300	0.750	3	3.0	0.312	O	O	O
3/8"-24	3824516-1CSF3AH	24	0.300	0.750	3	3.0	0.312	O	O	O
7/16"-14	7161438-1CSF3AH	14	0.350	0.786	3	3.0	0.375	O	O	O
7/16"-20	7162038-1CSF3AH	20	0.350	0.750	3	3.0	0.375	O	O	O
1/2"-13	121338-1CSF3AH	13	0.370	0.769	3	3.0	0.375	O	O	O
1/2"-20	122038-1CSF3AH	20	0.370	0.750	3	3.0	0.375	O	O	O
9/16"-12	9161212-1CSAH	12	0.430	0.750	4	4.0	0.500	O	O	O
9/16"-18	9161812-1CSAH	18	0.450	0.778	4	4.0	0.500	O	O	O
5/8"-11	581112-1CSAH	11	0.430	1.000	4	4.0	0.500	O	O	O
5/8"-18	581812-1CSAH	18	0.495	1.000	4	4.0	0.500	O	O	O
3/4"-10	341058-1CSAH	10	0.620	1.000	4	4.0	0.625	O	O	O
3/4"-16	341658-1CSAH	16	0.620	1.000	4	4.0	0.625	O	O	O
7/8"-9	780934-1CSAH	9	0.745	1.333	4	4.0	0.750	O	O	O
7/8"-14	781434-1CSAH	14	0.745	1.286	4	4.0	0.750	O	O	O
1"-8	010834-1CSAH	8	0.745	1.250	4	4.0	0.750	O	O	O
1"-12	011234-1CSAH	12	0.745	1.250	4	4.0	0.750	O	O	O

X = In Stock ; O = Special Order ; Other Coatings Available ; Call for Delivery

Other Sizes Available Upon Request

*Designates Staggered Thread

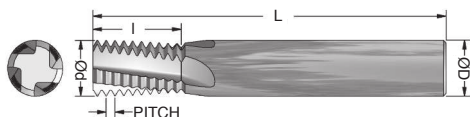

SOLID CARBIDE HELICAL THREAD MILLS



Metric Internal and External Threads

METRIC (M) INTERNAL THREADS

Dimensions in Inches (mm)

Minimum Size	Tool Number	Pitch	Cutter Diameter (d)	Length of Cut (l)	Number of Flutes	Length (L)	Shank Diameter (D)	Coatings Available		
								Un-Coated	Z TiAlN	V Hardmill
M6x1.0	M61.014-1CSF3BH	1.00	0.169 (4.3)	0.394 (10)	3	3.0 (76)	0.250	O	X	O
M6x0.75	M60.7514-1CSF3BH	0.75	0.169 (4.3)	0.413 (10.5)	3	3.0 (76)	0.250	O	X	O
M8x1.25	M81.2514-1CSF3BH	1.25	0.232 (5.9)	0.640 (16.25)	3	3.0 (76)	0.250	O	X	O
M8x1.0	M81.014-1CSF3BH	1.00	0.232 (5.9)	0.630 (16)	3	3.0 (76)	0.250	O	X	O
M10x1.5	M101.5516-1CSF3BH	1.50	0.287 (7.3)	0.768 (19.5)	3	3.0 (76)	0.312	O	X	O
M10x1.25	M101.25516-1CSF3BH	1.25	0.287 (7.3)	0.787 (20)	3	3.0 (76)	0.312	O	X	O
M12x1.75	M121.7538-1CSF3BH	1.75	0.370 (9.4)	0.827 (21)	3	3.0 (76)	0.375	O	X	O
M12x1.25	M121.2538-1CSF3BH	1.25	0.370 (9.4)	0.837 (21.25)	3	3.0 (76)	0.375	O	X	O
M14x2.0	M142.012-1CSBH	2.00	0.429 (10.9)	1.024 (26)	4	4.0 (102)	0.500	O	X	O
M14x1.5	M141.512-1CSBH	1.50	0.429 (10.9)	1.004 (25.5)	4	4.0 (102)	0.500	O	X	O
M18x2.5	M182.512-1CSBH	2.50	0.495 (12.57)	0.984 (25)	4	4.0 (102)	0.500	O	X	O
M18x1.5	M181.512-1CSBH	1.50	0.495 (12.57)	1.004 (25.5)	4	4.0 (102)	0.500	O	X	O
M24x3.0	M243.058-1CSBH	3.00	0.620 (15.75)	1.063 (27)	4	4.0 (102)	0.625	O	X	O
M24x2.0	M242.058-1CSBH	2.00	0.620 (15.75)	1.024 (26)	4	4.0 (102)	0.625	O	X	O
M30x3.5	M303.534-1CSBH	3.50	0.745 (18.9)	1.240 (31.5)	4	4.0 (102)	0.750	O	X	O
M36x4.0	M364.001-1CSF6BH	4.00	0.995 (25.27)	1.417 (36)	6	5.0 (127)	1.000	O	X	O

METRIC (M) EXTERNAL THREADS

Dimensions in Inches (mm)

Minimum Size	Tool Number	Pitch	Cutter Diameter (d)	Length of Cut (l)	Number of Flutes	Length (L)	Shank Diameter (D)	Coatings Available		
								Un-Coated	Z TiAlN	V Hardmill
M6x1.0	M61.014-1CSF3AH	1.00	0.169 (4.3)	0.394 (10)	3	3.0 (76)	0.250	O	O	O
M6x0.75	M60.7514-1CSF3AH	0.75	0.169 (4.3)	0.413 (10.5)	3	3.0 (76)	0.250	O	O	O
M8x1.25	M81.2514-1CSF3AH	1.25	0.232 (5.9)	0.640 (16.25)	3	3.0 (76)	0.250	O	O	O
M8x1.0	M81.014-1CSF3AH	1.00	0.232 (5.9)	0.630 (16)	3	3.0 (76)	0.250	O	O	O
M10x1.5	M101.5516-1CSF3AH	1.50	0.287 (7.3)	0.768 (19.5)	3	3.0 (76)	0.312	O	O	O
M10x1.25	M101.25516-1CSF3AH	1.25	0.287 (7.3)	0.787 (20)	3	3.0 (76)	0.312	O	O	O
M12x1.75	M121.7538-1CSF3AH	1.75	0.370 (9.4)	0.827 (21)	3	3.0 (76)	0.375	O	O	O
M12x1.25	M121.2538-1CSF3AH	1.25	0.370 (9.4)	0.837 (21.25)	3	3.0 (76)	0.375	O	O	O
M14x2.0	M142.012-1CSAH	2.00	0.429 (10.9)	1.024 (26)	4	4.0 (102)	0.500	O	O	O
M14x1.5	M141.512-1CSAH	1.50	0.429 (10.9)	1.004 (25.5)	4	4.0 (102)	0.500	O	O	O
M18x2.5	M182.512-1CSAH	2.50	0.495 (12.57)	0.984 (25)	4	4.0 (102)	0.500	O	O	O
M18x1.5	M181.512-1CSAH	1.50	0.495 (12.57)	1.004 (25.5)	4	4.0 (102)	0.500	O	O	O
M24x3.0	M243.058-1CSAH	3.00	0.620 (15.75)	1.063 (27)	4	4.0 (102)	0.625	O	O	O
M24x2.0	M242.058-1CSAH	2.00	0.620 (15.75)	1.024 (26)	4	4.0 (102)	0.625	O	O	O
M30x3.5	M303.534-1CSAH	3.50	0.745 (18.9)	1.240 (31.5)	4	4.0 (102)	0.750	O	O	O
M36x4.0	M364.001-1CSF6AH	4.00	0.995 (25.27)	1.417 (36)	6	5.0 (127)	1.000	O	O	O

X = In Stock ; O = Special Order ; Other Coatings Available ; Call for Delivery
Other Sizes Available Upon Request
*Designates Staggered Thread

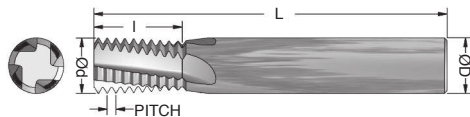

SOLID CARBIDE HELICAL THREAD MILLS



Metric (M) Internal & External Threads, Metric Shank

METRIC (M) INTERNAL THREADS, METRIC SHANK

Dimensions in Inches (mm)

Minimum Size	Tool Number	Pitch	Cutter Diameter (d)	Length of Cut (l)	Number of Flutes	Length (L)	Shank Diameter (D)	Coatings Available		
								Un-Coated	Z TiAlN	V Hardmill
M6x1.0	EM61.006-1CSF3BH	1.00	0.169 (4.3)	0.394 (10)	3	3.0 (76)	(6)	O	O	O
M6x0.75	EM60.7506-1CSF3BH	0.75	0.169 (4.3)	0.413 (10.5)	3	3.0 (76)	(6)	O	O	O
M8x1.25	EM81.2506-1CSF3BH	1.25	0.232 (5.9)	0.640 (16.25)	3	3.0 (76)	(6)	O	O	O
M8x1.0	EM81.006-1CSF3BH	1.00	0.232 (5.9)	0.630 (16)	3	3.0 (76)	(6)	O	O	O
M10x1.5	EM101.508-1CSF3BH	1.50	0.287 (7.3)	0.768 (19.5)	3	3.0 (76)	(8)	O	O	O
M10x1.25	EM101.2508-1CSF3BH	1.25	0.287 (7.3)	0.787 (20)	3	3.0 (76)	(8)	O	O	O
M12x1.75	EM121.7510-1CSF3BH	1.75	0.370 (9.4)	0.827 (21)	3	3.0 (76)	(10)	O	O	O
M12x1.25	EM121.2510-1CSF3BH	1.25	0.370 (9.4)	0.837 (21.25)	3	3.0 (76)	(10)	O	O	O
M14x2.0	EM142.012-1CSBH	2.00	0.429 (10.9)	1.024 (26)	4	3.5 (90)	(12)	O	O	O
M14x1.5	EM141.512-1CSBH	1.50	0.429 (10.9)	1.004 (25.5)	4	3.5 (90)	(12)	O	O	O
M18x2.5	EM182.512-1CSBH	2.50	0.469 (11.9)	0.984 (25)	4	3.5 (90)	(12)	O	O	O
M18x1.5	EM181.512-1CSBH	1.50	0.469 (11.9)	1.004 (25.5)	4	3.5 (90)	(12)	O	O	O
M24x3.0	EM243.016-1CSBH	3.00	0.626 (15.9)	1.063 (27)	4	3.98 (101)	(16)	O	O	O
M24x2.0	EM242.016-1CSBH	2.00	0.626 (15.9)	1.024 (26)	4	3.98 (101)	(16)	O	O	O
M30x3.5	EM303.520-1CSBH	3.50	0.783 (19.9)	1.240 (31.5)	4	4.0 (102)	(20)	O	O	O
M36x4.0	EM364.025-1CSF6BH	4.00	0.980 (24.9)	1.417 (36)	6	5.0 (157)	(25)	O	O	O

METRIC (M) EXTERNAL THREADS, METRIC SHANK

Dimensions in Inches (mm)

Minimum Size	Tool Number	Pitch	Cutter Diameter (d)	Length of Cut (l)	Number of Flutes	Length (L)	Shank Diameter (D)	Coatings Available		
								Un-Coated	Z TiAlN	V Hardmill
M6x1.0	EM61.006-1CSF3AH	1.00	0.169 (4.3)	0.394 (10)	3	3.0 (76)	(6)	O	O	O
M6x0.75	EM60.7506-1CSF3AH	0.75	0.169 (4.3)	0.413 (10.5)	3	3.0 (76)	(6)	O	O	O
M8x1.25	EM81.2506-1CSF3AH	1.25	0.232 (5.9)	0.640 (16.25)	3	3.0 (76)	(6)	O	O	O
M8x1.0	EM81.006-1CSF3AH	1.00	0.232 (5.9)	0.630 (16)	3	3.0 (76)	(6)	O	O	O
M10x1.5	EM101.508-1CSF3AH	1.50	0.287 (7.3)	0.768 (19.5)	3	3.0 (76)	(8)	O	O	O
M10x1.25	EM101.2508-1CSF3AH	1.25	0.287 (7.3)	0.787 (20)	3	3.0 (76)	(8)	O	O	O
M12x1.75	EM121.7510-1CSF3AH	1.75	0.370 (9.4)	0.827 (21)	3	3.0 (76)	(10)	O	O	O
M12x1.25	EM121.2510-1CSF3AH	1.25	0.370 (9.4)	0.837 (21.25)	3	3.0 (76)	(10)	O	O	O
M14x2.0	EM142.012-1CSAH	2.00	0.429 (10.9)	1.024 (26)	4	3.5 (90)	(12)	O	O	O
M14x1.5	EM141.512-1CSAH	1.50	0.429 (10.9)	1.004 (25.5)	4	3.5 (90)	(12)	O	O	O
M18x2.5	EM182.512-1CSAH	2.50	0.469 (11.9)	0.984 (25)	4	3.5 (90)	(12)	O	O	O
M18x1.5	EM181.512-1CSAH	1.50	0.469 (11.9)	1.004 (25.5)	4	3.5 (90)	(12)	O	O	O
M24x3.0	EM243.016-1CSAH	3.00	0.626 (15.9)	1.063 (27)	4	3.98 (101)	(16)	O	O	O
M24x2.0	EM242.016-1CSAH	2.00	0.626 (15.9)	1.024 (26)	4	3.98 (101)	(16)	O	O	O
M30x3.5	EM303.520-1CSAH	3.50	0.783 (19.9)	1.240 (31.5)	4	4.0 (102)	(20)	O	O	O
M36x4.0	EM364.025-1CSF6AH	4.00	0.980 (24.9)	1.417 (36)	6	5.0 (157)	(25)	O	O	O

X = In Stock ; O = Special Order ; Other Coatings Available ; Call for Delivery

Other Sizes Available Upon Request

*Designates Staggered Thread

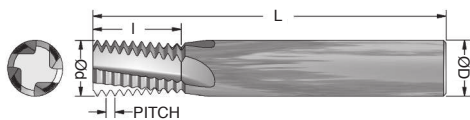

SOLID CARBIDE HELICAL THREAD MILLS



National Taper Pipe (NPT) Threads

NATIONAL TAPER PIPE (NPT) THREADS

Dimensions in Inches (mm)

Minimum Size	Tool Number	Pitch	Cutter Diameter (d)	Length of Cut (l)	Number of Flutes	Length (L)	Shank Diameter (D)	Coatings Available		
								Un-Coated	Z TiAlN	V Hardmill
1/8"-27	51627516-1CSNPTF3H	27	0.308	0.741	3	3.0	0.312	○	X	○
1/4"-18	381838-1CSNPTF3H	18	0.370	0.778	3	3.0	0.375	○	X	○
1/4"-18	7161812-1CSNPTH	18	0.432	0.778	4	4.0	0.500	○	X	○
1/2"-14	121412-1CSNPTH	14	0.495	1.000	4	4.0	0.500	○	X	○
1/2"-14	581458-1CSNPTH	14	0.620	1.000	4	4.0	0.625	○	X	○
1"-11.5	3411534-1CSNPTF5H	11.5	0.745	1.044	5	4.0	0.750	○	X	○
1"-11.5	0111501-1CSNPTF6H	11.5	0.995	1.391	6	5.0	1.000	○	X	○
2-1/2"-8	340834-1CSNPTH	8	0.745	1.125	4	4.0	0.750	○	X	○
2-1/2"-8	010801-1CSNPTF5H	8	0.995	1.500	5	5.0	1.000	○	X	○

NATIONAL TAPER PIPE (NPT) THREADS, METRIC SHANK

Dimensions in Inches (mm)

Minimum Size	Tool Number	Pitch	Cutter Diameter (d)	Length of Cut (l)	Number of Flutes	Length (L)	Shank Diameter (D)	Coatings Available		
								Un-Coated	Z TiAlN	V Hardmill
1/8"-27	E082708-1CSNPTF3H	27	0.311 (7.90)	0.741 (18.82)	3	3.0 (76)	(8)	○	○	○
1/4"-18	E101810-1CSNPTF3H	18	0.390 (9.90)	0.778 (19.76)	3	3.0 (76)	(10)	○	○	○
1/4"-18	E111812-1CSNPTH	18	0.429 (10.90)	0.778 (19.76)	4	3.5 (90)	(12)	○	○	○
1/2"-14	E121412-1CSNPTH	14	0.469 (11.90)	1.000 (25.40)	4	3.5 (90)	(12)	○	○	○
1/2"-14	E161416-1CSNPTH	14	0.626 (15.90)	1.000 (25.40)	4	3.98 (101)	(16)	○	○	○
1"-11.5	E2011520-1CSNPTF5H	11.5	0.783 (19.90)	1.044 (26.52)	5	4.0 (102)	(20)	○	○	○
1"-11.5	E2511525-1CSNPTF6H	11.5	0.980 (24.90)	1.391 (35.33)	6	5.0 (127)	(25)	○	○	○
2-1/2"-8	E200820-1CSNPTH	8	0.783 (19.90)	1.125 (28.58)	4	4.0 (102)	(20)	○	○	○
2-1/2"-8	E250825-1CSNPTF5H	8	0.980 (24.90)	1.500 (38.10)	5	5.0 (127)	(25)	○	○	○

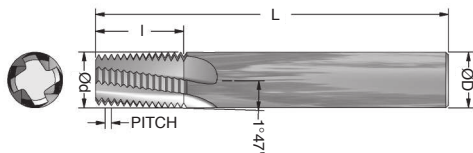

X = In Stock ; O = Special Order ; Other Coatings Available ; Call for Delivery
Other Sizes Available Upon Request - Tools will cut internal & external thread
*Designates Staggered Thread

SOLID CARBIDE HELICAL THREAD MILLS



British Standard Parallel Pipe (BSPP) Threads

BRITISH STANDARD PARALLEL PIPE (BSPP) THREADS

Dimensions in Inches (mm)

Minimum Size	Tool Number	Pitch	Cutter Diameter (d)	Length of Cut (l)	Number of Flutes	Length (L)	Shank Diameter (D)	Coatings Available		
								Un-Coated	Z TiAlN	V Hardmill
1/8"-28	1828516-1CSBSPF3H	28	0.300	0.750	3	3.0	0.312	○	X	○
1/4"-19	141938-1CSBSPF3H	19	0.370	0.789	3	3.0	0.375	○	X	○
1/2"-14	121458-1CSBSPH	14	0.620	1.000	4	4.0	0.625	○	X	○
3/4"-14	341434-1CSBSPH	14	0.745	1.286	4	4.0	0.750	○	X	○
1"-11	011134-1CSBSPH	11	0.745	1.272	4	4.0	0.750	○	X	○

BRITISH STANDARD PARALLEL PIPE (BSPP) THREADS, METRIC SHANK

Minimum Size	Tool Number	Pitch	Cutter Diameter (d)	Length of Cut (l)	Number of Flutes	Length (L)	Shank Diameter (D)	Coatings Available		
								Un-Coated	Z TiAlN	V Hardmill
1/8"-28	182808MM-1CSBSPF3H	28	0.300 (7.6)	0.750 (19)	3	3.0 (76)	(8)	○	○	○
1/4"-19	141910MM-1CSBSPF3H	19	0.390 (9.9)	0.789 (20)	3	3.0 (76)	(10)	○	○	○
1/2"-14	121416MM-1CSBSPH	14	0.626 (15.9)	1.000 (25.4)	4	3.98 (101)	(16)	○	○	○
3/4"-14	341420MM-1CSBSPH	14	0.783 (19.9)	1.286 (32.7)	4	4.0 (102)	(20)	○	○	○
1"-11	011120MM-1CSBSPH	11	0.783 (19.9)	1.272 (32.3)	4	4.0 (102)	(20)	○	○	○

BRITISH STANDARD PIPE TAPER (BSPT) THREADS

Minimum Size	Tool Number	Pitch	Cutter Diameter (d)	Length of Cut (l)	Number of Flutes	Length (L)	Shank Diameter (D)	Coatings Available		
								Un-Coated	Z TiAlN	V Hardmill
1/8"-28	1828516-1CSBSPTF3H	28	0.300	0.750	3	3.0	0.312	○	X	○
1/4"-19	141938-1CSBSPTF3H	19	0.370	0.789	4	3.0	0.375	○	X	○
1/2"-14	121458-1CSBSPTH	14	0.620	1.000	4	4.0	0.625	○	X	○
3/4"-14	341434-1CSBSPTH	14	0.745	1.286	4	4.0	0.750	○	X	○
1"-11	011134-1CSBSPTH	11	0.745	1.272	4	4.0	0.750	○	X	○

BRITISH STANDARD PIPE TAPER (BSPT) THREADS, METRIC SHANK

Minimum Size	Tool Number	Pitch	Cutter Diameter (d)	Length of Cut (l)	Number of Flutes	Length (L)	Shank Diameter (D)	Coatings Available		
								Un-Coated	Z TiAlN	V Hardmill
1/8"-28	182808MM-1CSBSPTF3H	28	0.300 (7.6)	0.750 (19)	3	3.0 (76)	(8)	○	○	○
1/4"-19	141910MM-1CSBSPTF3H	19	0.390 (9.9)	0.789 (20)	3	3.0 (76)	(10)	○	○	○
1/2"-14	121416MM-1CSBSPTH	14	0.626 (15.9)	1.000 (25.4)	4	3.98 (101)	(16)	○	○	○
3/4"-14	341420MM-1CSBSPTH	14	0.783 (19.9)	1.286 (32.7)	4	4.0 (102)	(20)	○	○	○
1"-11	011120MM-1CSBSPTH	11	0.783 (19.9)	1.272 (32.3)	4	4.0 (102)	(20)	○	○	○

X = In Stock ; O = Special Order ; Other Coatings Available ; Call for Delivery
Other Sizes Available Upon Request - Tools will cut internal & external thread
*Designates Staggered Thread

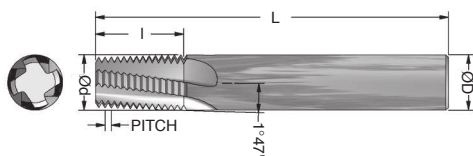

SOLID CARBIDE EXTENDED LENGTH THREAD MILL HIGH HELIX, COOLANT THRU (K)



- 30° Helix = High Performance Tools
- Other sizes and forms available upon request
- Difficult Materials Thread Milling
- Length of Cut = 2.25 x Thread Size Diameter
- Coolant Thru the Center
- Tools will cut INTERNAL thread only

Dimensions in Inches

Minimum Size	Tool Number	Pitch	Cutter Diameter (d)	Length of Cut	Length	Number of Flutes	Shank Diameter	Coatings Available		
								Uncoated	Z TiAlN	V Hardmill
1/2"-12	121238-BH3KL12	12	0.370	1.167	3.0	4	0.375	○	○	X
1/2"-13	121338-BH3KL12	13	0.370	1.154	3.0	4	0.375	○	○	X
1/2"-14	121438-BH3KL11	14	0.370	1.143	3.0	4	0.375	○	○	X
1/2"-16	121638-BH3KL11	16	0.370	1.125	3.0	4	0.375	○	○	X
1/2"-18	121838-BH3KL12	18	0.370	1.167	3.0	4	0.375	○	○	X
1/2"-20	122038-BH3KL12	20	0.370	1.150	3.0	4	0.375	○	○	X
1/2"-24	122438-BH3KL11	24	0.370	1.125	3.0	4	0.375	○	○	X
1/2"-27	122738-BH3KL11	27	0.370	1.148	3.0	4	0.375	○	○	X
1/2"-28	122838-BH3KL11	28	0.370	1.143	3.0	4	0.375	○	○	X
1/2"-32	123238-BH3KL11	32	0.370	1.125	3.0	4	0.375	○	○	X
9/16"-12	9161212-BH3KL13	12	0.430	1.250	4.0	4	0.500	○	○	X
9/16"-14	9161412-BH3KL13	14	0.450	1.286	4.0	4	0.500	○	○	X
9/16"-16	9161612-BH3KL13	16	0.450	1.250	4.0	4	0.500	○	○	X
9/16"-18	9161812-BH3KL13	18	0.450	1.278	4.0	4	0.500	○	○	X
9/16"-20	9162012-BH3KL13	20	0.450	1.250	4.0	4	0.500	○	○	X
9/16"-24	9162412-BH3KL13	24	0.450	1.250	4.0	4	0.500	○	○	X
9/16"-28	9162812-BH3KL13	28	0.450	1.250	4.0	4	0.500	○	○	X
9/16"-32	9163212-BH3KL13	32	0.450	1.250	4.0	4	0.500	○	○	X
5/8"-11	581112-BH3KL15	11	0.470	1.455	4.0	4	0.500	○	○	X
5/8"-14	581412-BH3KL14	14	0.495	1.429	4.0	4	0.500	○	○	X
5/8"-16	581612-BH3KL14	16	0.495	1.438	4.0	4	0.500	○	○	X
5/8"-18	581812-BH3KL14	18	0.495	1.444	4.0	4	0.500	○	○	X
5/8"-20	582012-BH3KL14	20	0.495	1.400	4.0	4	0.500	○	○	X
5/8"-24	582412-BH3KL14	24	0.495	1.417	4.0	4	0.500	○	○	X
5/8"-28	582812-BH3KL14	28	0.495	1.429	4.0	4	0.500	○	○	X

continued...

SOLID CARBIDE EXTENDED LENGTH THREAD MILL HIGH HELIX, COOLANT THRU (K) *CONTINUED*

- 30° Helix = High Performance Tools
- Difficult Materials Thread Milling
- Length of Cut = 2.25 x Thread Size Diameter
- Other sizes and forms available upon request
- Coolant Thru the Center
- Tools will cut INTERNAL thread only

Dimensions in Inches

Minimum Size	Tool Number	Pitch	Cutter Diameter (d)	Length of Cut	Length	Number of Flutes	Shank Diameter	Coatings Available		
								Uncoated	Z TiAIN	V Hardmill
3/4"-10	341058-BH3KL17	10	0.620	1.700	4.0	5	0.625	O	O	X
3/4"-12	341258-BH3KL18	12	0.620	1.750	4.0	5	0.625	O	O	X
3/4"-14	341458-BH3KL17	14	0.620	1.714	4.0	5	0.625	O	O	X
3/4"-16	341658-BH3KL17	16	0.620	1.688	4.0	5	0.625	O	O	X
3/4"-18	341858-BH3KL17	18	0.620	1.667	4.0	5	0.625	O	O	X
3/4"-20	342058-BH3KL17	20	0.620	1.700	4.0	5	0.625	O	O	X
3/4"-24	342458-BH3KL17	24	0.620	1.667	4.0	5	0.625	O	O	X
3/4"-28	342858-BH3KL17	28	0.620	1.679	4.0	5	0.625	O	O	X
3/4"-32	343258-BH3KL17	32	0.620	1.688	4.0	5	0.625	O	O	X
7/8"-9	780934-BH3KL20	9	0.725	2.000	5.0	6	0.750	O	O	X
7/8"-10	781034-BH3KL20	10	0.745	2.000	5.0	6	0.750	O	O	X
7/8"-12	781234-BH3KL20	12	0.745	2.000	5.0	6	0.750	O	O	X
7/8"-14	781434-BH3KL20	14	0.745	2.000	5.0	6	0.750	O	O	X
7/8"-16	781634-BH3KL20	16	0.745	2.000	5.0	6	0.750	O	O	X
7/8"-18	781834-BH3KL20	18	0.745	2.000	5.0	6	0.750	O	O	X
7/8"-20	782034-BH3KL20	20	0.745	2.000	5.0	6	0.750	O	O	X
7/8"-24	782434-BH3KL20	24	0.745	2.000	5.0	6	0.750	O	O	X
7/8"-28	782834-BH3KL20	28	0.745	2.000	5.0	6	0.750	O	O	X
7/8"-32	783234-BH3KL20	32	0.745	2.000	5.0	6	0.750	O	O	X
1"-7	010734-BH3KL23	7	0.745	2.286	5.0	6	0.750	O	O	X
1"-8	010834-BH3KL23	8	0.745	2.250	5.0	6	0.750	O	O	X
1 1/4"-7	1250701-BH3KL29	7	0.995	2.857	5.0	6	1.000	O	O	X
1 1/4"-8	1250801-BH3KL29	8	0.995	2.875	5.0	6	1.000	O	O	X
1 3/8"-6	1380601-BH3KL32	6	0.995	3.167	6.0	6	1.000	O	O	X

*X = In Stock ; O = Special Order ; Other Coatings Available ; Call for Delivery
Other Sizes Available Upon Request
Designates Staggered Thread

SOLID CARBIDE EXTENDED LENGTH E2 & E3 THREAD MILL DESIGNATION

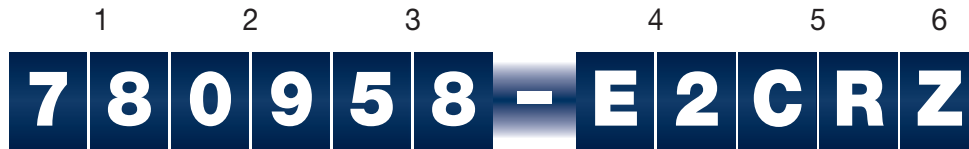

Column 1: Minimum Size Thread

- 12 = No. 12 - 0.216" (1228316-28 Pitch Tool)
- 10 = No. 10 - 0.190"
- 14 = 1/4" - 0.250"
- 516 = 5/16" - 0.3125"
- 38 = 3/8" - 0.375"
- 716 = 7/16" - 0.4375"
- 12 = 1/2" - 0.500" (1213516-13 Pitch Tool)
- 916 = 9/16" - 0.5625"
- 58 = 5/8" - 0.625"
- 1116 = 11/16" - 0.6875"
- 34 = 3/4" - 0.750"
- 78 = 7/8" - 0.875"
- 01 = 1" - 1.000"

Column 2: Threads per Inch

Column 3: Solid Carbide Shank Size

- 316 = Shank Ø0.1875"
- 14 = Shank Ø0.250"
- 516 = Shank Ø0.3125"
- 38 = Shank Ø0.375"
- 12 = Shank Ø0.500"
- 58 = Shank Ø0.625"

Column 4: E2 = One Skipped Tooth

E3 = Two Skipped Teeth

Column 5: CR = Cam Ground Carbide

Column 6: Coating

- "-" = Uncoated
- C = TiN – (Titanium Nitride)
- Y = TiCN – (Titanium Carbonitride)
- Z = TiAlN (Titanium Aluminum Nitride)
- V = Hardmill (Aluminum Titanium Nitride)
- X = ZrN (Zirconium Nitride)

For Coating Descriptions - See Page 17.

SOLID CARBIDE EXTENDED LENGTH THREAD MILLS

One Skipped Form E2 & Two Skipped Form E3- Unified (UN)

ONE SKIPPED FROM E2 - UNIFIED (UN)

Dimensions in Inches

Minimum Size	Tool Number	Pitch	Cutter Diameter (d)	Length of Cut (l)	Number of Flutes	Length (L)	Shank Diameter (D)	Coatings Available		
								Uncoated	Z TiAlN	V Hardmill
#10-24	1024316-E2CR	24	0.140	0.500	3	2.5	0.188	O	X	O
#12-28	1228316-E2CR	28	0.160	0.500	3	2.5	0.188	O	X	O
1/4"-28	142814-E2CR	28	0.180	0.750	3	3.0	0.250	O	X	O
1/4"-20	1420316-E2CR	20	0.160	0.500	3	2.5	0.188	O	X	O
5/16"-24	5162414-E2CR	24	0.200	0.833	3	3.0	0.250	O	X	O
5/16"-18	5161814-E2CR	18	0.200	0.667	3	3.0	0.250	O	X	O
3/8"-24	382414-E2CR	24	0.240	0.833	5	3.0	0.250	O	X	O
3/8"-16	381614-E2CR	16	0.240	0.750	5	3.0	0.250	O	X	O
7/16"-20	71620516-E2CR	20	0.310	1.000	5	3.0	0.312	O	X	O
7/16"-14	71614516-E2CR	14	0.310	0.857	5	3.0	0.312	O	X	O
1/2"-13	1213516-E2CR	13	0.310	1.077	5	3.0	0.312	O	X	O
9/16"-12	9161238-E2CR	12	0.370	1.333	5	3.0	3.750	O	X	O
5/8"-11	581112-E2CR	11	0.437	1.455	5	4.0	0.500	O	X	O
11/16"-16	11161612-E2CR	16	0.470	1.625	5	4.0	0.500	O	X	O
3/4"-12	341212-E2CR	12	0.470	1.500	5	4.0	0.500	O	X	O
3/4"-10	341012-E2CR	10	0.470	1.600	5	4.0	0.500	O	X	O
7/8"-9	780958-E2CR	9	0.620	2.000	6	4.0	0.625	O	X	O
1"-8	010858-E2CR	8	0.620	2.000	6	4.0	0.625	O	X	O

TWO SKIPPED FORM E3 - UNIFIED (UN)

Dimensions in Inches

Minimum Size	Tool Number	Pitch	Cutter Diameter (d)	Length of Cut (l)	Number of Flutes	Length (L)	Shank Diameter (D)	Coatings Available		
								Uncoated	Z TiAlN	V Hardmill
#10-24	1024316-E3CR	24	0.140	0.750	3	2.5	0.188	O	X	O
#12-28	1228316-E3CR	28	0.160	0.750	3	2.5	0.188	O	X	O
1/4"-28	142814-E3CR	28	0.180	0.750	3	3.0	0.250	O	X	O
1/4"-20	1420316-E3CR	20	0.160	0.750	3	2.5	0.188	O	X	O
5/16"-24	5162414-E3CR	24	0.200	1.000	3	3.0	0.250	O	X	O
5/16"-18	5161814-E3CR	18	0.200	1.000	3	3.0	0.250	O	X	O
3/8"-24	382414-E3CR	24	0.240	1.000	5	3.0	0.250	O	X	O
3/8"-16	381614-E3CR	16	0.240	1.125	5	3.0	0.250	O	X	O
7/16"-20	71620516-E3CR	20	0.310	1.200	5	3.0	0.312	O	X	O
7/16"-14	71614516-E3CR	14	0.310	1.286	5	3.0	0.312	O	X	O
1/2"-13	1213516-E3CR	13	0.310	1.385	5	3.0	0.312	O	X	O
9/16"-12	9161238-E3CR	12	0.370	1.500	5	3.0	0.375	O	X	O
5/8"-11	581112-E3CR	11	0.437	1.909	5	4.0	0.500	O	X	O
3/4"-12	341212-E3CR	12	0.470	2.000	5	4.0	0.500	O	X	O
3/4"-10	341012-E3CR	10	0.470	2.100	5	4.0	0.500	O	X	O
7/8"-9	780958-E3CR	9	0.620	2.000	6	4.0	0.625	O	X	O
1"-8	010858-E3CR	8	0.620	2.250	6	4.0	0.625	O	X	O
1-1/8"-7	1120758-E3CR	7	0.620	2.143	6	4.0	0.625	O	X	O

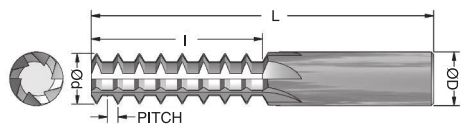

X = In Stock ; O = Special Order ; Other Coatings Available ; Call for Delivery
Other Sizes Available Upon Request - Tools will cut internal threads only
*Designates Staggered Thread

SINGLE POINT TOOLS

- Carbide Shank
- Hardened Tool Steel Replaceable Head
- Thru Coolant
- Deep Holes 8X Shank Diameter or Greater

1/2" & 12MM SINGLE POINT TOOLS

TOOL ASSEMBLY		
Part Number	Description	Length (L1)
ASPA-12K4AX45	1/2" Single Point Assembly	4.5"
ASPA-12K4AX65	1/2" Single Point Assembly	6.5"
ASPA-12MMK4AX45	12mm Single Point Assembly	4.5"
ASPA-12MMK4AX65	12mm Single Point Assembly	6.5"

INSERTS (6)			
Part Number	Thread Size Min	Pitch Range	Cut Diameter (D)
ASP12H(8-9UN)Z	7/8"-8UN	8 - 9 UN	0.700
ASP12H(10UN)Z	3/4"-10UN	10 UN	0.630
ASP12H(12-16UN)Z	3/4"-12UN	12 - 16 UN	0.630
ASP12H(18-40UN)Z	3/4"-18UN, 1/2"-14NPT	18 - 40 UN	0.630
ASP12H(2.5-1.0MM)Z	M20 X 2.5	2.5 - 1.0 MM	0.650

5/8" & 16MM SINGLE POINT TOOLS

TOOL ASSEMBLY		
Part Number	Description	Length (L1)
ASPA-58K6AX70	5/8" Single Point Assembly	7.0"
ASPA-58K6AX130	5/8" Single Point Assembly	13.0"
ASPA-16MMK6AX70	16mm Single Point Assembly	7.0"
ASPA-16MMK6AX130	16mm Single Point Assembly	13.0"

INSERTS (6)			
Part Number	Thread Size Min	Pitch Range	Cut Diameter (D)
ASP58H(7UN)Z	1 1/8"-7UN	7 UN	0.870
ASP58H(8UN)Z	1"-8UN	8 UN	0.810
ASP58H(9-11UN)Z	1"-9UN	9 - 11 UN	0.810
ASP58H(12-16UN)Z	7/8"-12UN, 1"-11.5NPT	12 - 16 UN	0.750
ASP58H(18-40UN)Z	7/8"-18UN	18 - 40 UN	0.750
ASP58H(3.0MM)Z	M24 X 3.0	3.0 MM	0.790
ASP58H(2.5-1.5MM)Z	M24 X 2.5	2.5 - 1.5 MM	0.790

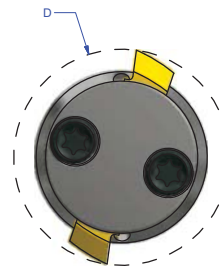
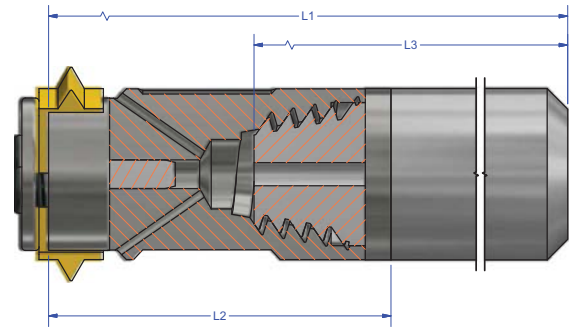

SINGLE POINT TOOLS

- Carbide Shank
- Hardened Tool Steel Replaceable Head
- Thru Coolant
- Deep Holes 8X Shank Diameter or Greater

3/4" & 20MM SINGLE POINT TOOLS

TOOL ASSEMBLY		
Part Number	Description	Length (L1)
ASPA-34K6AX70	3/4" Single Point Assembly	7.0"
ASPA-34K6AX130	3/4" Single Point Assembly	13.0"
ASPA-20MMK6AX70	20mm Single Point Assembly	7.0"
ASPA-20MMK6AX130	20mm Single Point Assembly	13.0"

INSERTS (6)			
Part Number	Thread Size Min	Pitch Range	Cut Diameter (D)
ASP34H(6-9UN)Z	1 1/4"-6UN	6 - 9 UN	1.000
ASP34H(10-16UN)Z	1 1/4"-10UN, 1"-11.5NPT	10 - 16 UN	1.000
ASP34H(18-40UN)Z	1 1/4"-18UN	18 - 40 UN	1.000
ASP34H(4.0-3.5MM)Z	M36 X 4.0	4.0 - 3.5 MM	1.000
ASP34H(2.5-1.5MM)Z	M30 X 2.5	2.5 - 1.5 MM	1.000

1" & 25MM SINGLE POINT TOOLS

TOOL ASSEMBLY		
Part Number	Description	Length (L1)
ASPA-01K8AX70	1" Single Point Assembly	7.0"
ASPA-01K8AX100	1" Single Point Assembly	10.0"
ASPA-01K8AX130	1" Single Point Assembly	13.0"
ASPA-25MMK8AX70	25mm Single Point Assembly	7.0"
ASPA-25MMK8AX100	25mm Single Point Assembly	10.0"
ASPA-25MMK8AX130	25mm Single Point Assembly	13.0"

INSERTS (6)			
Part Number	Thread Size Min	Pitch Range	Cut Diameter (D)
ASP01H(4-4.5UN)Z	2 1/2"-4UN, 2"-4.5UN	4 - 4.5 UN	1.500
ASP01H(5UN)Z	1 3/4"-5UN	5 UN	1.400
ASP01H(5.5UN)Z	1 3/4"-5.5UN	5.5 UN	1.400
ASP01H(6UN)Z	1 1/2"-6UN	6 UN	1.250
ASP01H(7-16UN)Z	1 1/2"-7UN 1 1/4"-11.5NPT	7 - 16 UN	1.250
ASP01H(18-40UN)Z	1 1/2"-18UN	18 - 40 UN	1.250
ASP01H(6.0MM)Z	M64 X 6.0	6.0 MM	1.500
ASP01H(5.0MM)Z	M48 X 5.0	5.0 MM	1.400
ASP01H(4.5MM)Z	M42 X 4.5	4.5 MM	1.400
ASP01H(4.0MM)Z	M42 X 4.0	4.0 MM	1.400
ASP01H(3.5-3.0MM)Z	M42 X 3.5	3.5 - 3.0 MM	1.400
ASP01H(2.5-1.5MM)Z	M36 X 2.5	2.5 - 1.5 MM	1.250

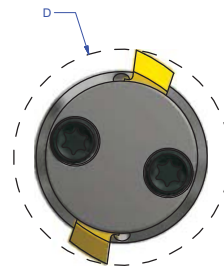
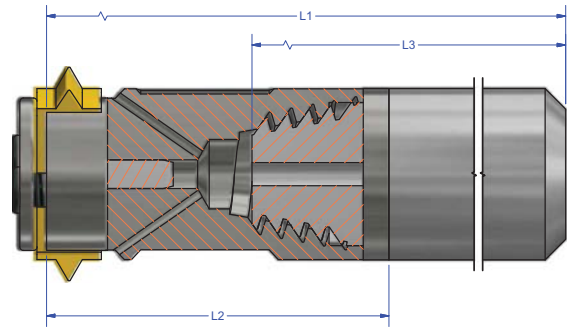

SINGLE POINT TOOLS - REPLACEABLE PARTS

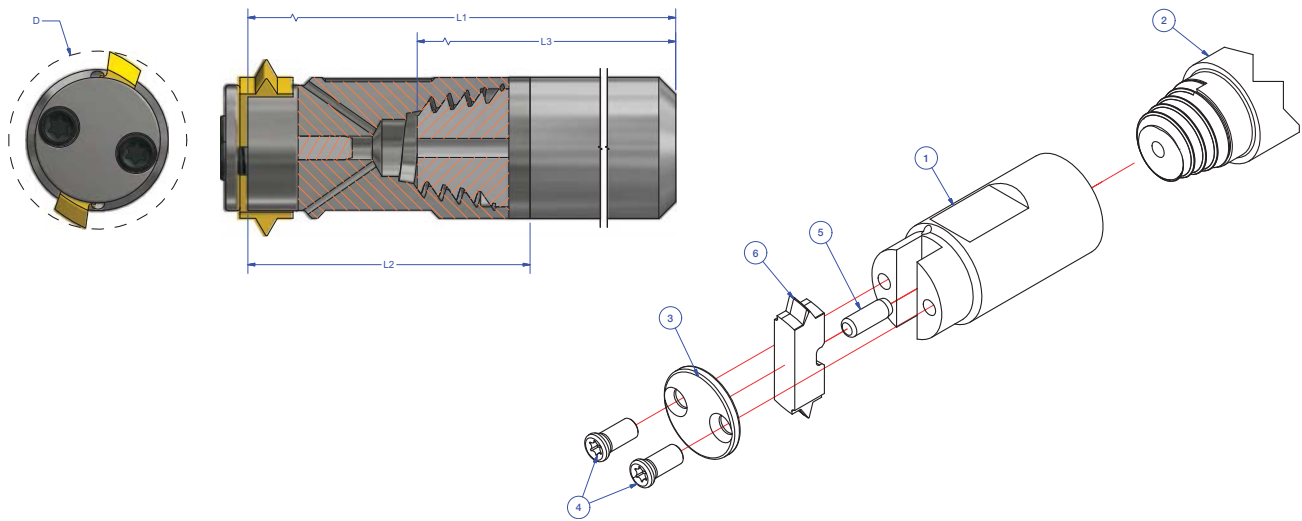

1/2" & 12MM SINGLE POINT TOOLS

REPLACEABLE PART NUMBERS		
Head (1)	Description	Length (L2)
ASPB-12HD4A	Single Point 1/2" Head, 4A Size	1.0"
Shank (2)	Description	Length (L3)
ASPB-12SK40	1/2" Carbide Shank	4.0"
ASPB-12SK60	1/2" Carbide Shank	6.0"
ASPB-12MMSK40	12mm Carbide Shank	4.0"
ASPB-12MMSK60	12mm Carbide Shank	6.0"
End Cap (3)	Description	
ASPB-12HDE	End Cap for 1/2" Head	
Screws (4)	Description	
PT464-8IP	M2.5 X 0.45-6H,8IP TORXPLUS	
Pin (5)	Description	
ATM-PIN33214	Locating Pin	

5/8" & 16MM SINGLE POINT TOOLS

REPLACEABLE PART NUMBERS		
Head (1)	Description	Length (L2)
ASPB-58HD6A	Single Point 5/8" Head, 6A Size	1.5"
Shank (2)	Description	Length (L3)
ASPB-58SK60	5/8" Carbide Shank	6.0"
ASPB-58SK120	5/8" Carbide Shank	12.0"
ASPB-16MMSK60	16mm Carbide Shank	6.0"
ASPB-16MMSK120	16mm Carbide Shank	12.0"
End Cap (3)	Description	
ASPB-58HDE	End Cap for 5/8" Head	
Screws (4)	Description	
PT464-8IP	M2.5 X 0.45-6H,8IP TORXPLUS	
Pin (5)	Description	
ATM-PIN33214	Locating Pin	

3/4" & 20MM SINGLE POINT TOOLS

REPLACEABLE PART NUMBERS		
Head (1)	Description	Length (L2)
ASPB-34HD6A	Single Point 3/4" Head, 6A Size	1.5"
Shank (2)	Description	Length (L3)
ASPB-34SK60	3/4" Carbide Shank	6.0"
ASPB-34SK120	3/4" Carbide Shank	12.0"
ASPB-20MMSK60	20mm Carbide Shank	6.0"
ASPB-20MMSK120	20mm Carbide Shank	12.0"
End Cap (3)	Description	
ASPB-34HDE	End Cap for 3/4" Head	
Screws (4)	Description	
PT464-8IP	M2.5 X 0.45-6H,8IP TORXPLUS	
Pin (5)	Description	
ATM-PIN33214	Locating Pin	

1" & 25MM SINGLE POINT TOOLS

REPLACEABLE PART NUMBERS		
Head (1)	Description	Length (L2)
ASPB-01HD8A	Single Point 1" Head, 8A Size	1.5"
Shank (2)	Description	Length (L3)
ASPB-01SK60	1" Carbide Shank	6.0"
ASPB-01SK90	1" Carbide Shank	9.0"
ASPB-01SK120	1" Carbide Shank	12.0"
ASPB-25MMSK60	25mm Carbide Shank	6.0"
ASPB-25MMSK90	25mm Carbide Shank	9.0"
ASPB-25MMSK120	25mm Carbide Shank	12.0"
End Cap (3)	Description	
ASPB-01HDE	End Cap for 1" Head	
Screws (4)	Description	
PT483T-15IP	M4 X 0.7-6H,15IP TORXPLUS	
Pin (5)	Description	
ATM-PIN33214	Locating Pin	



25005 Joe Meier Pkwy, Suite 100
Trevor, Wisconsin 53179
847-395-9707 / 1-800-847-3234
Info@adventtoolusa.com

