

ARNO[®]

WERKZEUGE

We have a passion for precision.

EIN- UND ABSTECHEN

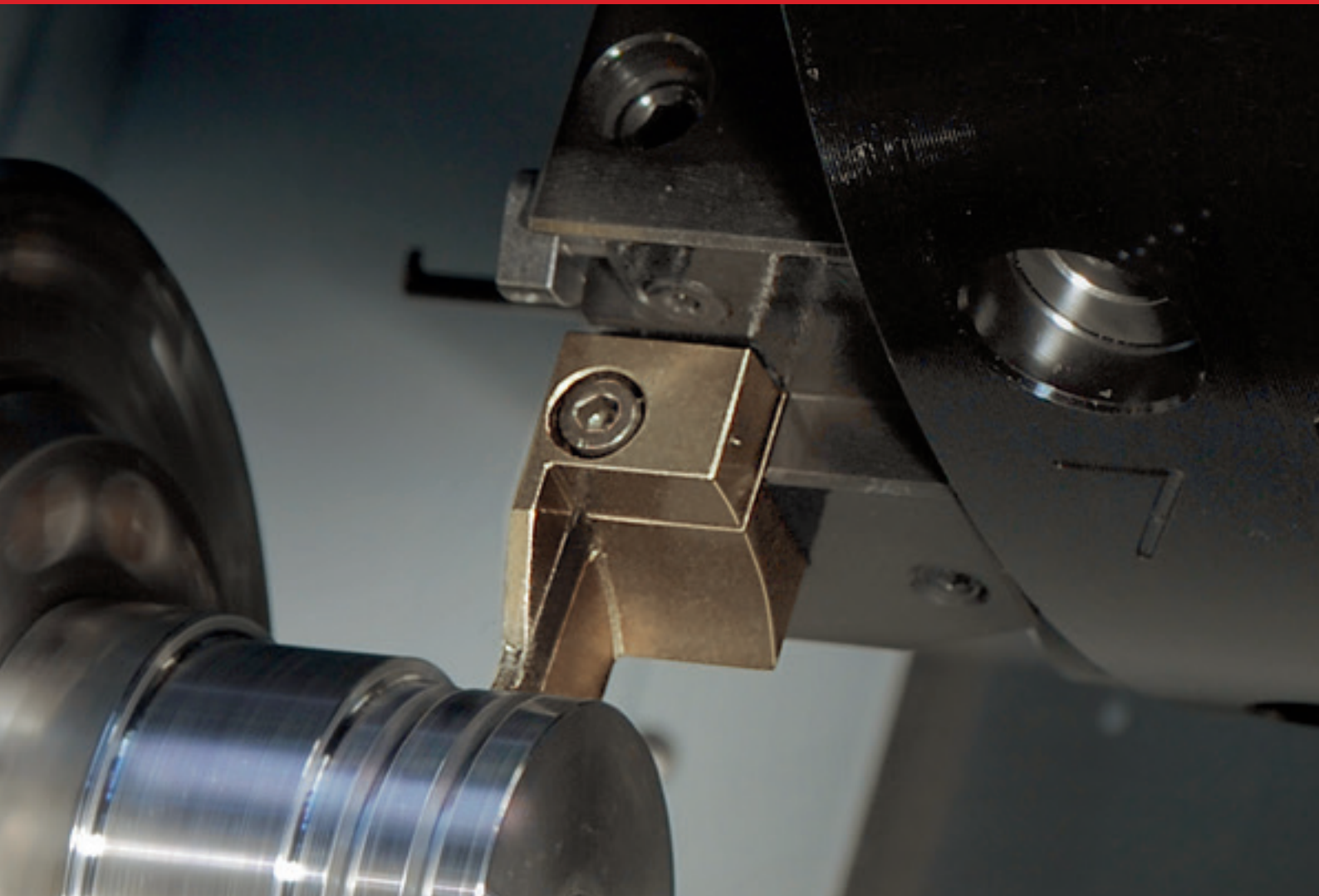

Werkzeuge und Schneideinsätze zum Ein- und Abstechen

*Tools and inserts
for parting and grooving*

Utensili ed inserti
di troncatura e scanalatura

Abstechen SA-Stecksystem

Parting-off with SA-Grooving system

Troncatura con SA-Sistema

0

<p>Direktaufnahmen Flange mounted holders Attacchi base</p> <p>BMT (Daewoo/Doosan; Mori Seiki) Nakamura/Mijano ...</p>	9
<p>SA-Module SA-Modules SA-Moduli</p> <p>EB = 1,5 – 4,0 mm ET ≤ 70,0 mm</p> <p>Ausführung R/L / Design R/L / Esecuzione R/L</p>	1

<p>Direktaufnahmen Flange mounted holders Attacchi base</p> <p>VDI ...</p> <p>Ausführung R/L / Design R/L / Esecuzione R/L</p>	9
<p>SA-Module MSA-IN SA-Modules MSA-IN SA-Moduli MSA-IN</p> <p>EB = 1,5 – 3,0 mm ET ≤ 26,0 mm</p> <p>Ausführung Neutral / Design neutral / Esecuzione neutro</p>	1
<p>KMH-Werkzeughalter mit Kühlmitteldüse KMH tool-holders with coolant jet Adattatori KMH con ugello refrigerante</p>	9
<p>SA-System Monoblockhalter SA-System monoblock holders SA-Sistema utensili monoblocco</p> <p>EB = 1,5 – 6,0 mm ET ≤ 32,5 mm</p> <p>Ausführung R/L / Design R/L / Esecuzione R/L</p>	1
<p>Halter für SA-Modul Tool holders for SA-Modules Steli per moduli SA</p>	1

NC-Stechedrehen
 NC-Groove turning system
 NC-Sistema di scanalatura

Schäfte / Shank / Steli
 8x8 – 32x32 mm

Ausführung gerade/abgesetzt
 Design straight/crianked
 Esecuzione dritto/inclinato

3

SA-Module
 SA-Modules
 SA-Moduli

EB = 1,5 – 4,0 mm
ET ≤ 70,0 mm

1

Direktaufnahmen
 Flange mounted holders
 Attacchi base

VDI ...

9

SA-Module
 SA-Modules
 SA-Moduli

EB = 1,5 – 4,0 mm
ET ≤ 70,0 mm

1

NC-Stechedrehen
 NC-Groove turning system/NC-Sistema di scanalatura

UTS/KM, PSC

3

SA-Module
 SA-Modules/SA-Moduli

EB = 1,5 – 4,0 mm
ET ≤ 70,0 mm

1

NC-Stechedrehen
 NC-Groove turning system
 NC-Sistema di scanalatura

VDI

3

SA-Module
 SA-Modules/SA-Moduli

EB = 1,5 – 4,0 mm
ET ≤ 70,0 mm

1

SA-Spannblock
 SA-Clamping block/SA-Blocco portalama

Für Stechklingen KSA 26.../KSA 32...
 For part-off blades KSA 26.../KSA 32...
 Per lame da taglio KSA 26.../KSA 32...

1

SA-Stechklingen
 SA part-off blades/SA Lame da taglio

EB = 2,0 – 4,0 mm

1

Spannblock mit Kühlmitteldüse
 Clamping block with coolant jet
 Blocco portalama con ugello refrigerante

Für Stechklingen KSA 26.../KSA 32...
 For part-off blades KSA 26.../KSA 32...
 Per lame da taglio KSA 26.../KSA 32...

1

SA-Stechklingen
 SA Part-off blades/SA Lame da taglio

Verstärkte Ausführung
 Reinforced blade design
 Lama rinforzata

EB = 1,5 – 3,0 mm
ET ≤ 32,5 mm

1

NC-Stechedrehen
 NC-Groove turning system
 NC-Sistema di scanalatura

VDI-Halter/VDI-holder/Adattatore VDI

3

SA-Module
 SA-Modules
 SA-Moduli

EB = 1,5 – 4,0 mm
ET ≤ 70,0 mm

1

NC-Stechedrehen
 NC-Groove turning system
 NC-Sistema di scanalatura

UTS/KM, PSC

3

SA-Module
 SA-Modules
 SA-Moduli

EB = 1,5 – 4,0 mm
ET ≤ 70,0 mm

1

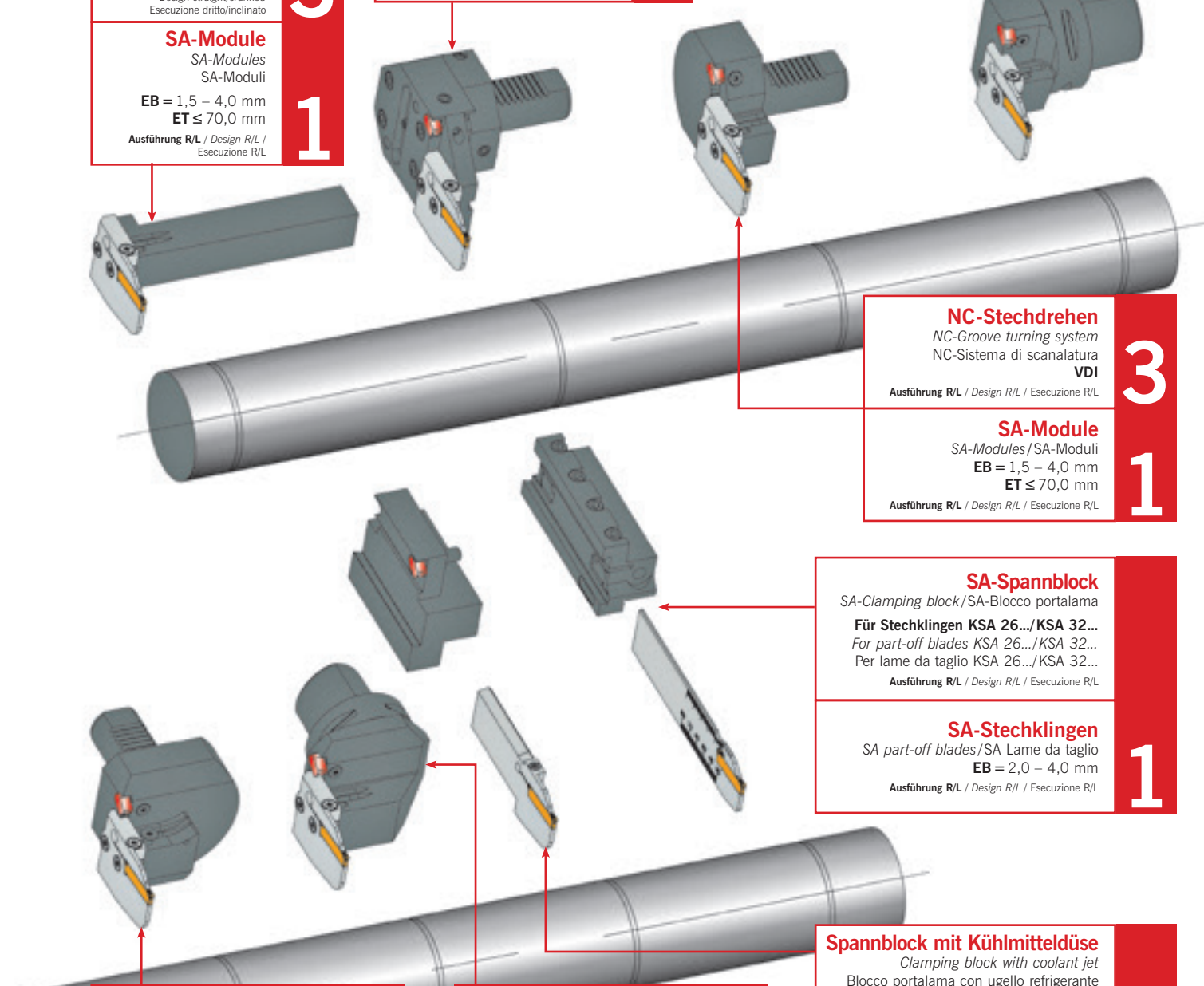

Abstechen – SA-Steichsystem mit Innenkühlung ACS

Parting-off – SA-Grooving system with internal coolant ACS

Troncatura – SA-Sistema con adduzione interna ACS



0

Direktaufnahmen Flange mounted holders Attacchi base BMT (Daewoo/Doosan; Mori Seiki) Mijano ... Ausführung R/L / Design R/L / Esecuzione R/L	9 1
SA-Module mit ACS SA-Modules with ACS SA-Moduli con ACS EB = 3,0 – 4,0 mm ET ≤ 52,5 mm Ausführung R/L / Design R/L / Esecuzione R/L	

Werkzeughalter Polygonschaft mit Innenkühlung Polygon-Shank tool holder with internal coolant Attacco poligonale con refrigerante interna Auf Anfrage erhältlich / Available on request / Disponibile su richiesta Ausführung R/L / Design R/L / Esecuzione R/L	1
SA-Module mit ACS SA-Modules with ACS SA-Moduli con ACS EB = 3,0 – 4,0 mm ET ≤ 52,5 mm Ausführung R/L / Design R/L / Esecuzione R/L	

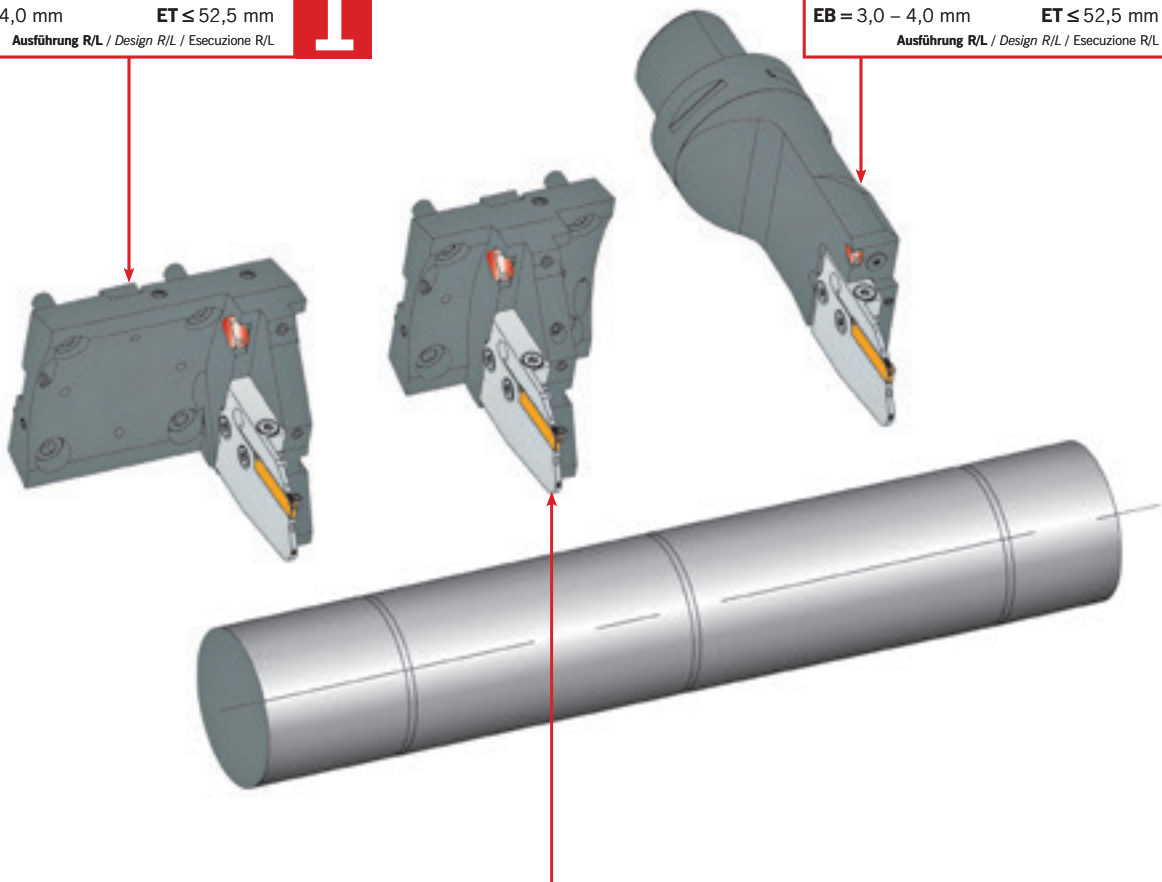

Direktaufnahmen Flange mounted holders Attacchi base BMT (Daewoo/Doosan; Mori Seiki) Nakamura/Mijano ...	9 1
SA-Module mit ACS SA-Modules with ACS SA-Moduli con ACS EB = 3,0 – 4,0 mm ET ≤ 52,5 mm Ausführung R/L / Design R/L / Esecuzione R/L	

SA-System Monoblockhalter mit ACS
 SA-System monoblock holders with ACS
 SA-Sistema utensili monoblocco con ACS
EB = 3,0 mm **ET ≤ 33,0 mm**
 Ausführung R/L / Design R/L / Esecuzione R/L

1

Direktaufnahmen
 Flange mounted holders
 Attacchi base
VDI
 Ausführung R/L / Design R/L / Esecuzione R/L

9

SA-Module mit ACS
 SA-Modules with ACS
 SA-Moduli con ACS
EB = 3,0 – 4,0 mm **ET ≤ 52,5 mm**
 Ausführung R/L / Design R/L / Esecuzione R/L

1

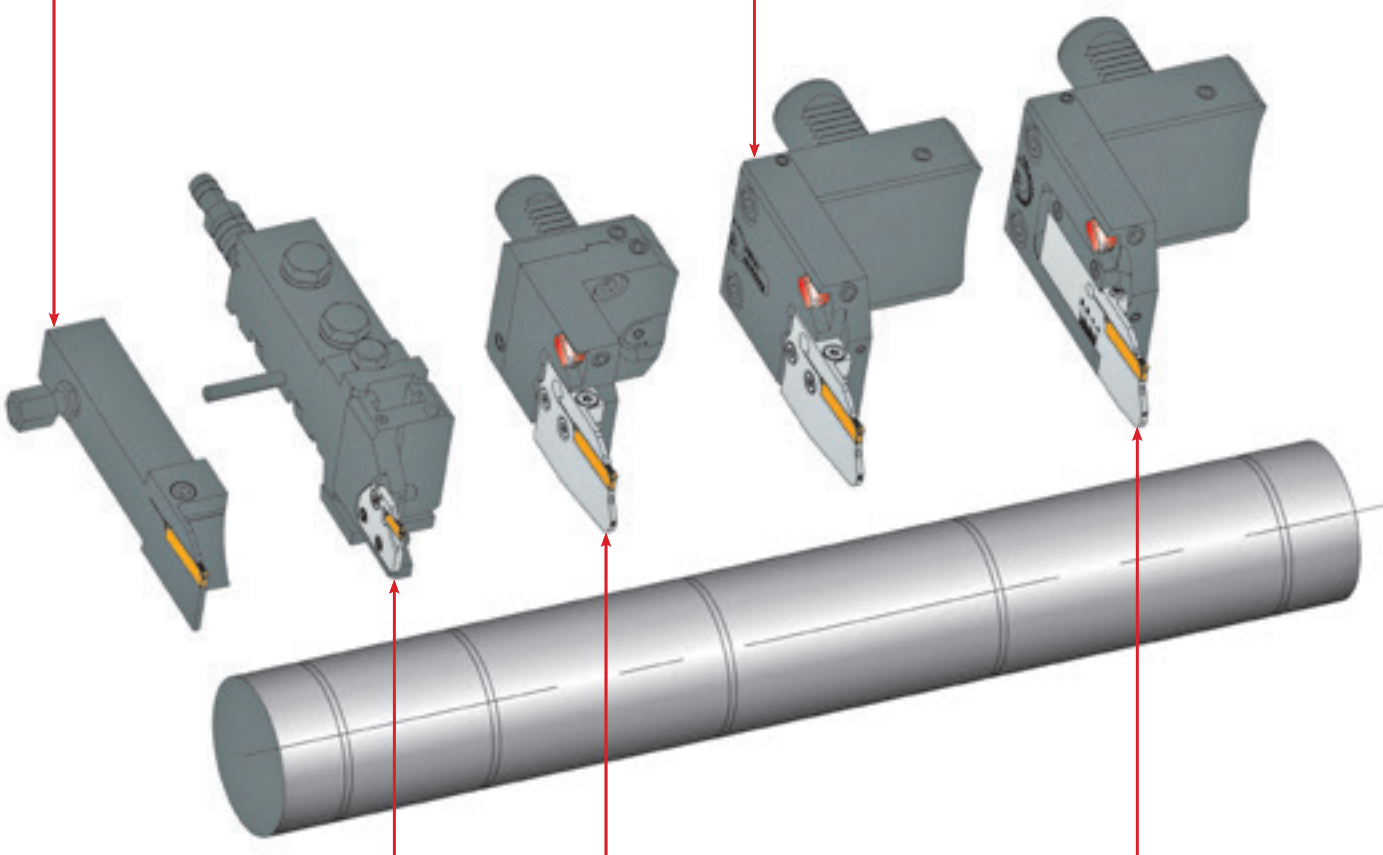

SA-Module MSA-IN
 SA-Modules MSA-IN
 SA-Moduli MSA-IN
Auf Anfrage erhältlich / Available on request / Disponibile su richiesta
 Ausführung Neutral / Design neutral / Esecuzione neutro

1

Direktaufnahmen
 Flange mounted holders
 Attacchi base
VDI ...
 Ausführung R/L / Design R/L / Esecuzione R/L

9

SA-Module mit ACS
 SA-Modules with ACS
 SA-Moduli con ACS
EB = 3,0 – 4,0 mm **ET ≤ 52,5 mm**
 Ausführung R/L / Design R/L / Esecuzione R/L

1

Direktaufnahmen
 Flange mounted holders
 Attacchi base
VDI
 Ausführung R/L / Design R/L / Esecuzione R/L

9

Klinge für VDI-Direktaufnahme mit ACS
 Part-off blade for VDI flange mounted holder with ACS
 Lama da taglio a attacchi base VDI con ACS
EB = 3,0 mm **ET ≤ 32,5 mm**
 Ausführung R/L / Design R/L / Esecuzione R/L

1

Abstechen SE-Stecksystem

Parting-off with SE-Grooving system

Troncatura con SE-Sistema

0

KMH-Werkzeughalter mit Kühlmitteldüse

KMH tool-holders with coolant jet
Adattatori KMH con ugello refrigerante

KMH01 B1

9

KMH-Werkzeughalter mit Kühlmitteldüse

KMH tool-holders with coolant jet
Adattatori KMH con ugello refrigerante

KMH01 C2

9

SE-System Monoblockhalter mit ACS1

SE-System monoblock holders with ACS1
SE-Sistema utensili monoblocco con ACS1

EB = 3,0 mm

ET ≤ 21,0 mm

Ausführung L / Design L / Esecuzione L

ACS1 von hinten oder von der Seite

ACS1 from behind or from the side

ACS da dietro o lateralmente

2

SE-System Monoblockhalter für KMH

SE-System monoblock holders for KMH
SA-Sistema utensili monoblocco per KMH

EB = 3,0 mm

ET ≤ 21,0 mm

Ausführung L / Design L / Esecuzione L

2

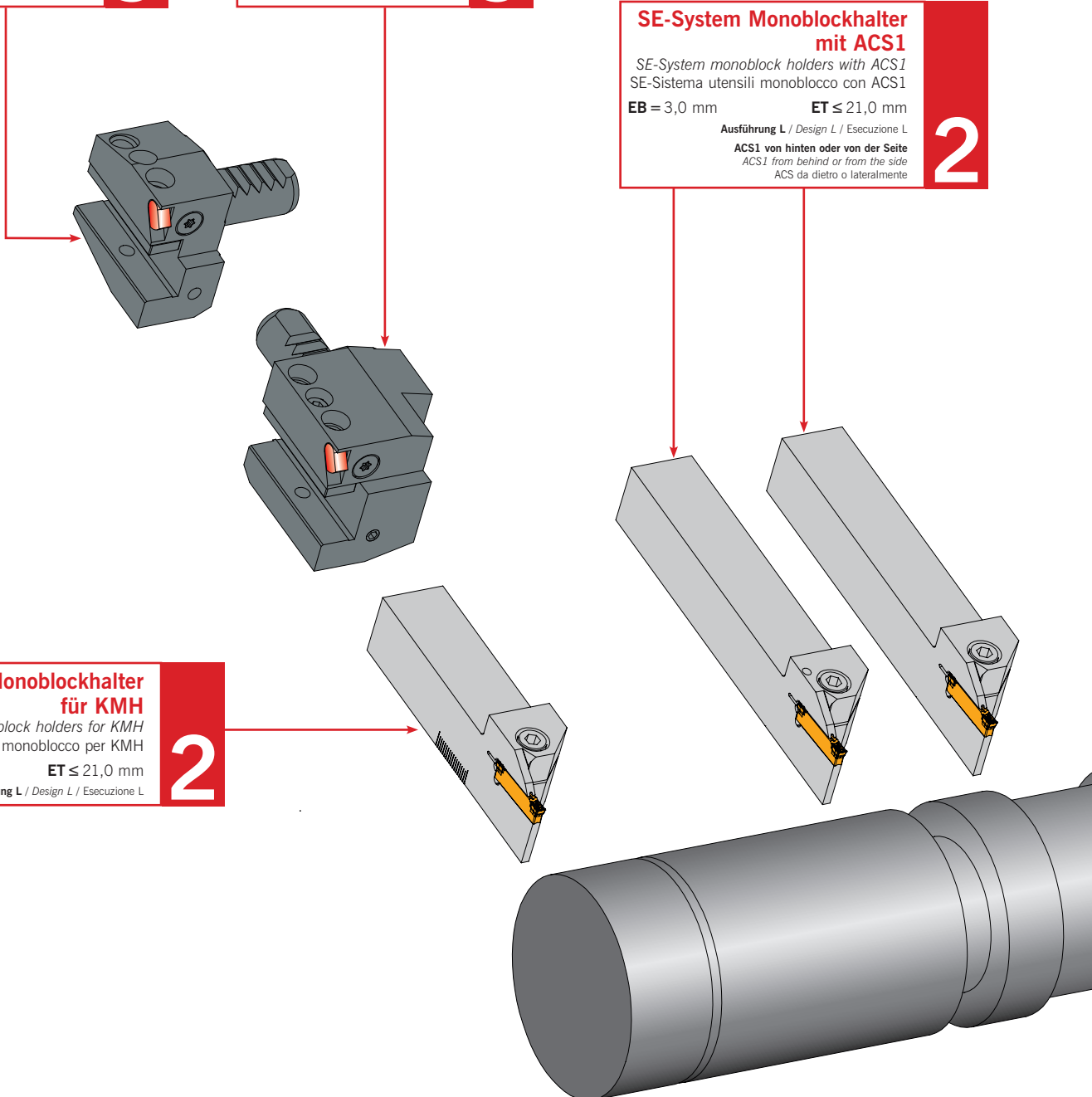

SE-System Monoblockhalter mit ACS1
 SE-System monoblock holders with ACS1
 SE-Sistema utensili monoblocco con ACS1
EB = 3,0 mm **ET ≤ 21,0 mm**
 Ausführung L / Design L / Esecuzione L
ACS1 von hinten oder von der Seite
 ACS1 from behind or from the side
 ACS1 da dietro o lateralmente

2

SE-System Monoblockhalter mit ACS1
 SE-System monoblock holders with ACS1
 SE-Sistema utensili monoblocco con ACS1
EB = 3,0 mm **ET ≤ 21,0 mm**
 Ausführung L / Design L / Esecuzione L
ACS1 von der Seite mit Spannung von oben und unten
 ACS1 from side with clamping from above and below
 ACS1 da lateralmente con bloccaggio dall'alto e dal basso

2

SE-System Monoblockhalter mit ACS1
 SE-System monoblock holders with ACS1
 SE-Sistema utensili monoblocco con ACS1
EB = 3,0 mm **ET ≤ 21,0 mm**
 Ausführung R / Design R / Esecuzione R
ACS1 von der Seite für Langdrehautomaten
 ACS1 from the side for screw type machines
 ACS1 da lateralmente per torri a fantina mobile

2

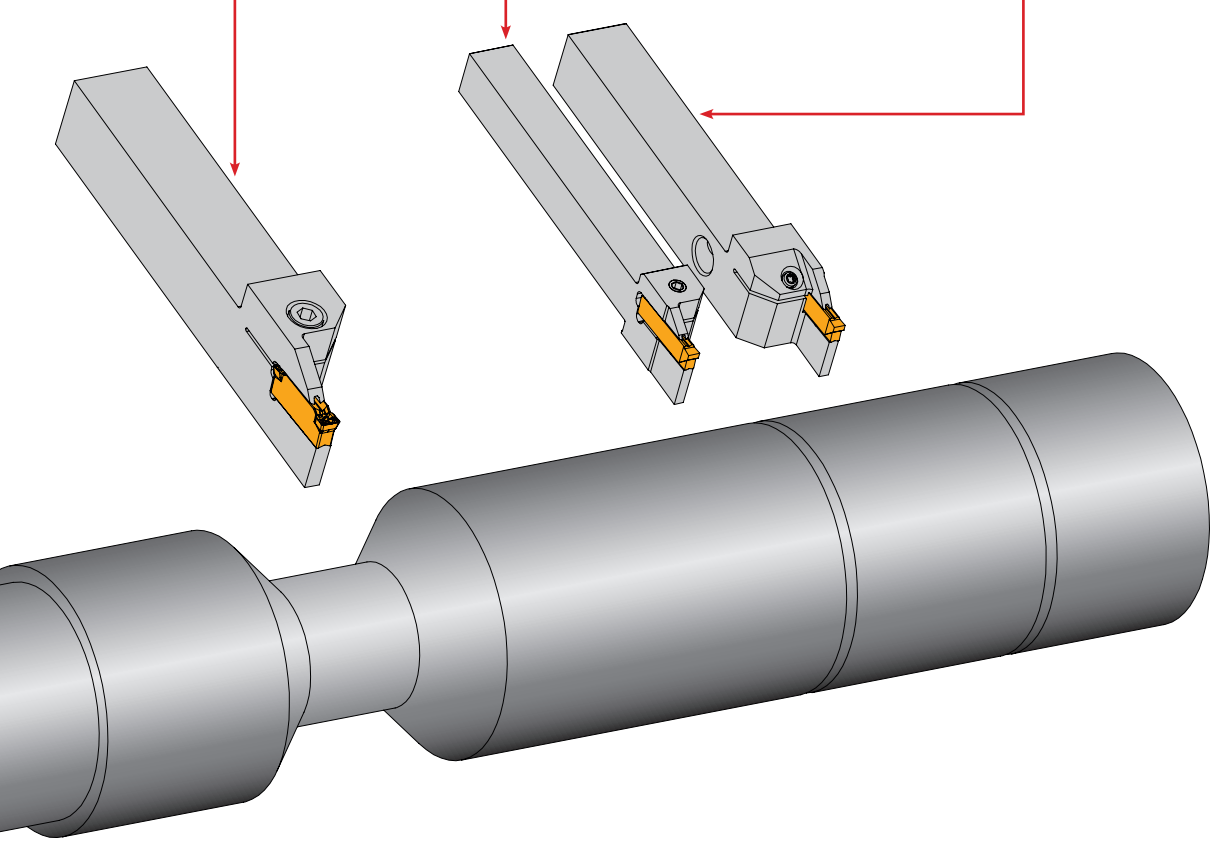

Radial-Stechedrehen

Radial groove turning

Scanalatura di copiatura radiale

0

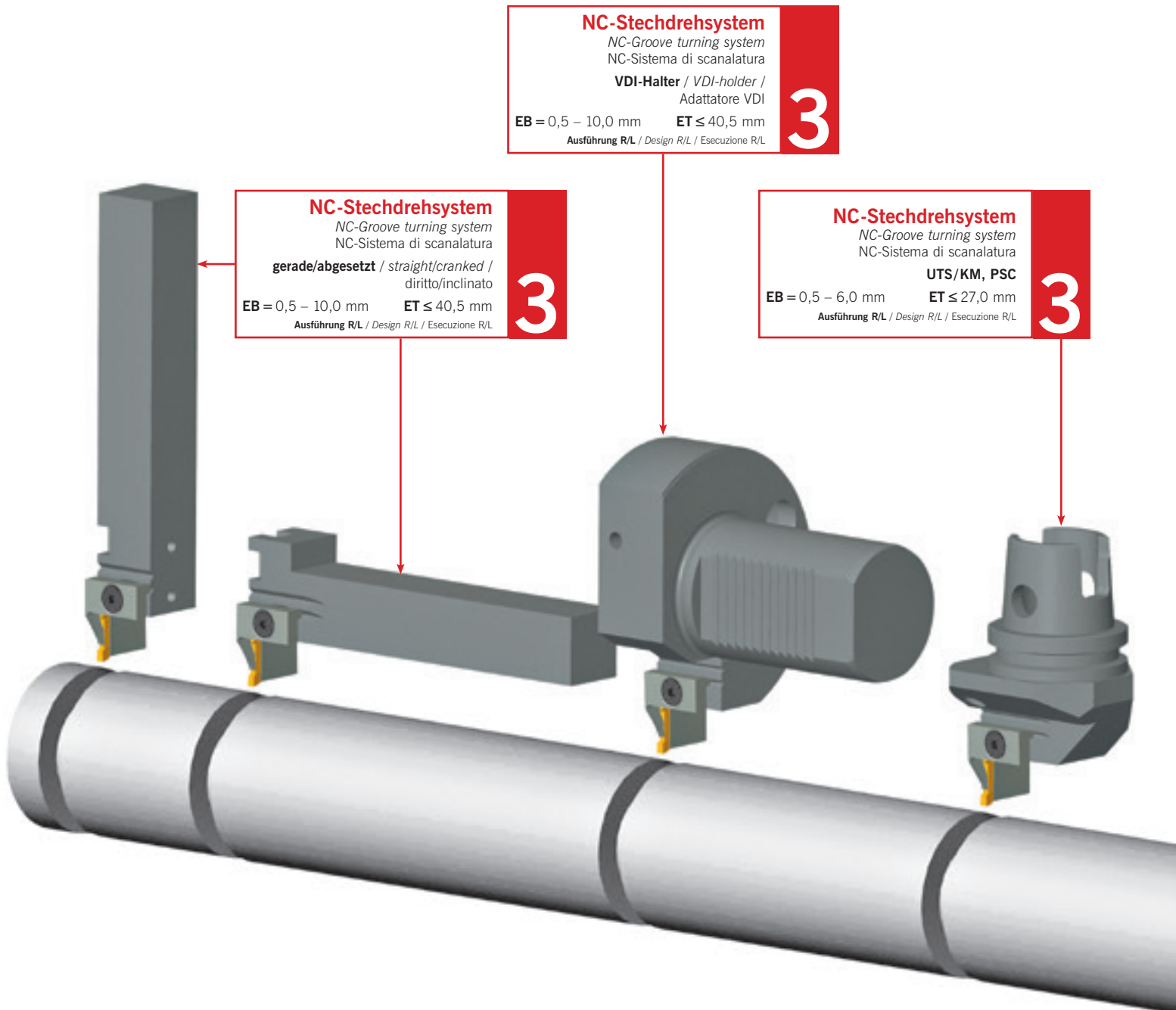

NC-Stechedrehsystem
NC-Groove turning system
NC-Sistema di scanalatura
VDI-Halter / VDI-holder /
Adattatore VDI
EB = 0,5 – 10,0 mm ET ≤ 40,5 mm
Ausführung R/L / Design R/L / Esecuzione R/L **3**

NC-Stechedrehsystem
NC-Groove turning system
NC-Sistema di scanalatura
gerade/abgesetzt / straight/cranked /
diritto/inclinato
EB = 0,5 – 10,0 mm ET ≤ 40,5 mm
Ausführung R/L / Design R/L / Esecuzione R/L **3**

NC-Stechedrehsystem
NC-Groove turning system
NC-Sistema di scanalatura
UTS/KM, PSC
EB = 0,5 – 6,0 mm ET ≤ 27,0 mm
Ausführung R/L / Design R/L / Esecuzione R/L **3**

SHORT-Cut®
 EB = 3,1 – 10,1 mm
 ET ≤ 16,5/27 mm
 Ausführung R/L / Design R/L / Esecuzione R/L

4

Clip-Groove®
 EB = 0,55 – 5,0 mm
 ET ≤ 10 mm
 Ausführung R/L / Design R/L / Esecuzione R/L

5

NC-Stechedrehsystem
 NC-Groove turning system
 NC-Sistema di scanalatura
 45°
 EB = 2,0 – 6,0 mm ET ≤ 27,0 mm
 D_{min} = 25 mm – ∞
 Ausführung R/L / Design R/L / Esecuzione R/L

3

Profil-Cut
 EB ≤ 25 mm
 Ausführung R/L / Design R/L / Esecuzione R/L

6

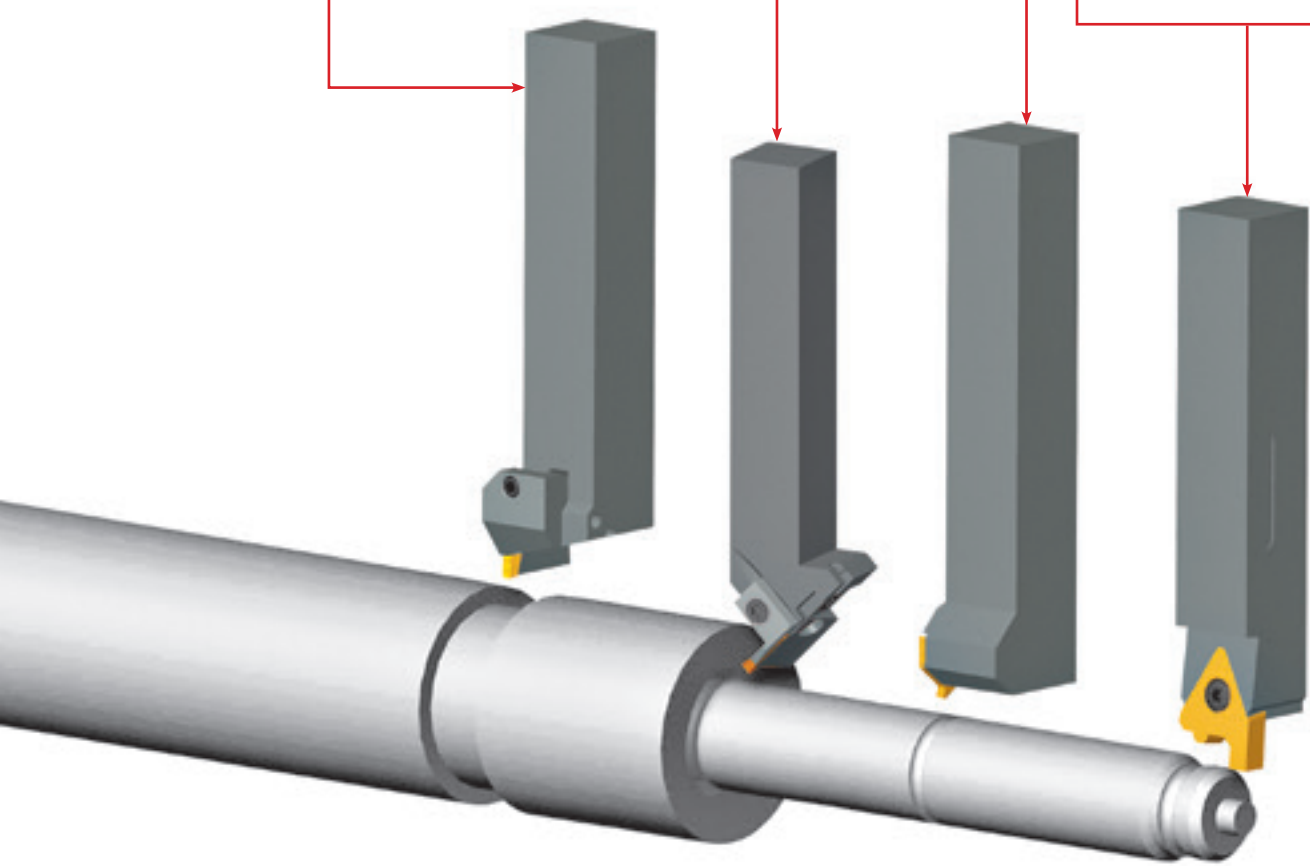

Radial-Stechdrehen – Für Langdrehautomaten

Radial groove turning – For screw type machines

Scanalatura di copiatura radiale – Per torni a fantina mobile

0

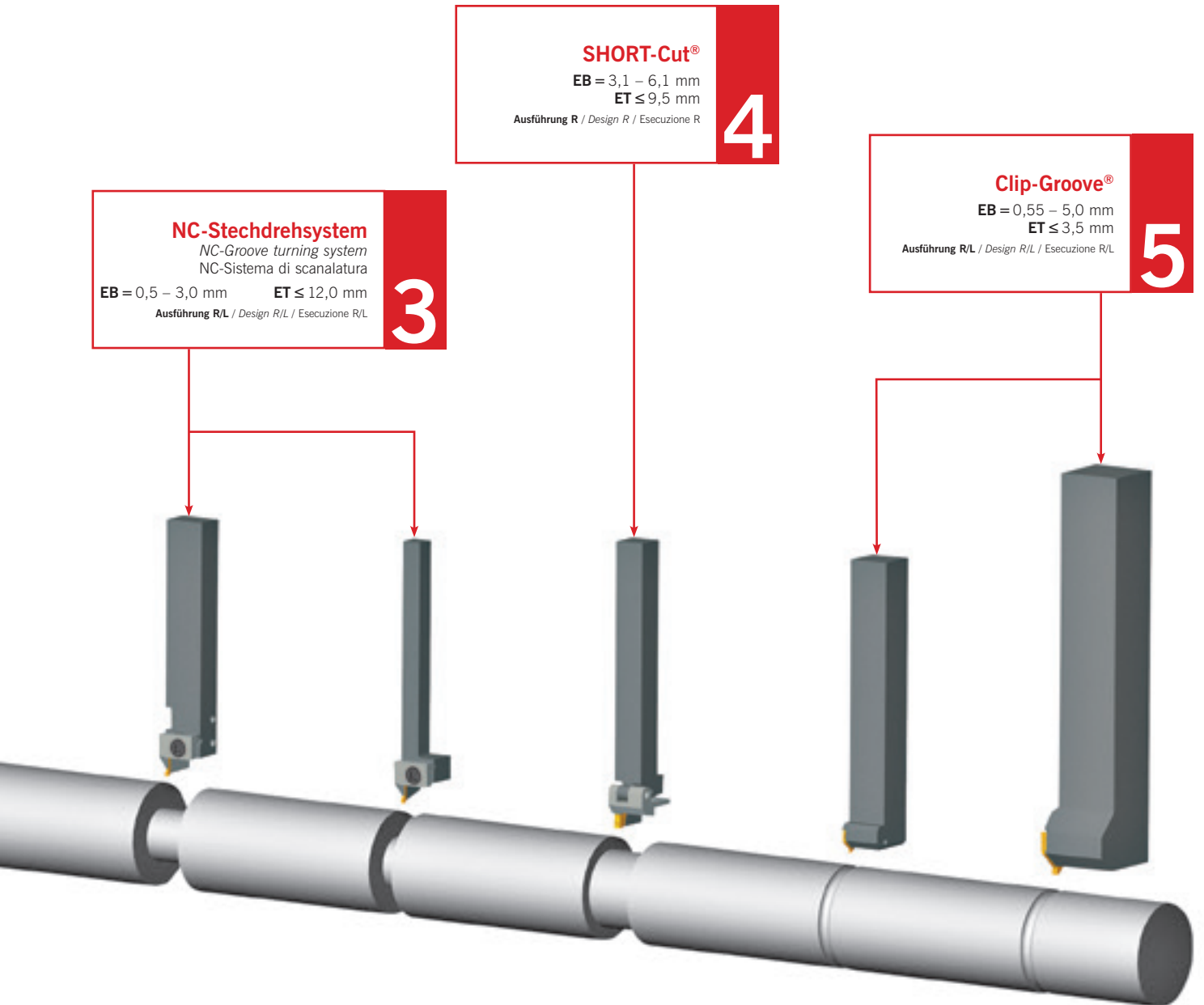

Axial-Stechedrehen

Axial groove turning

Scanalatura di copiatura assiale

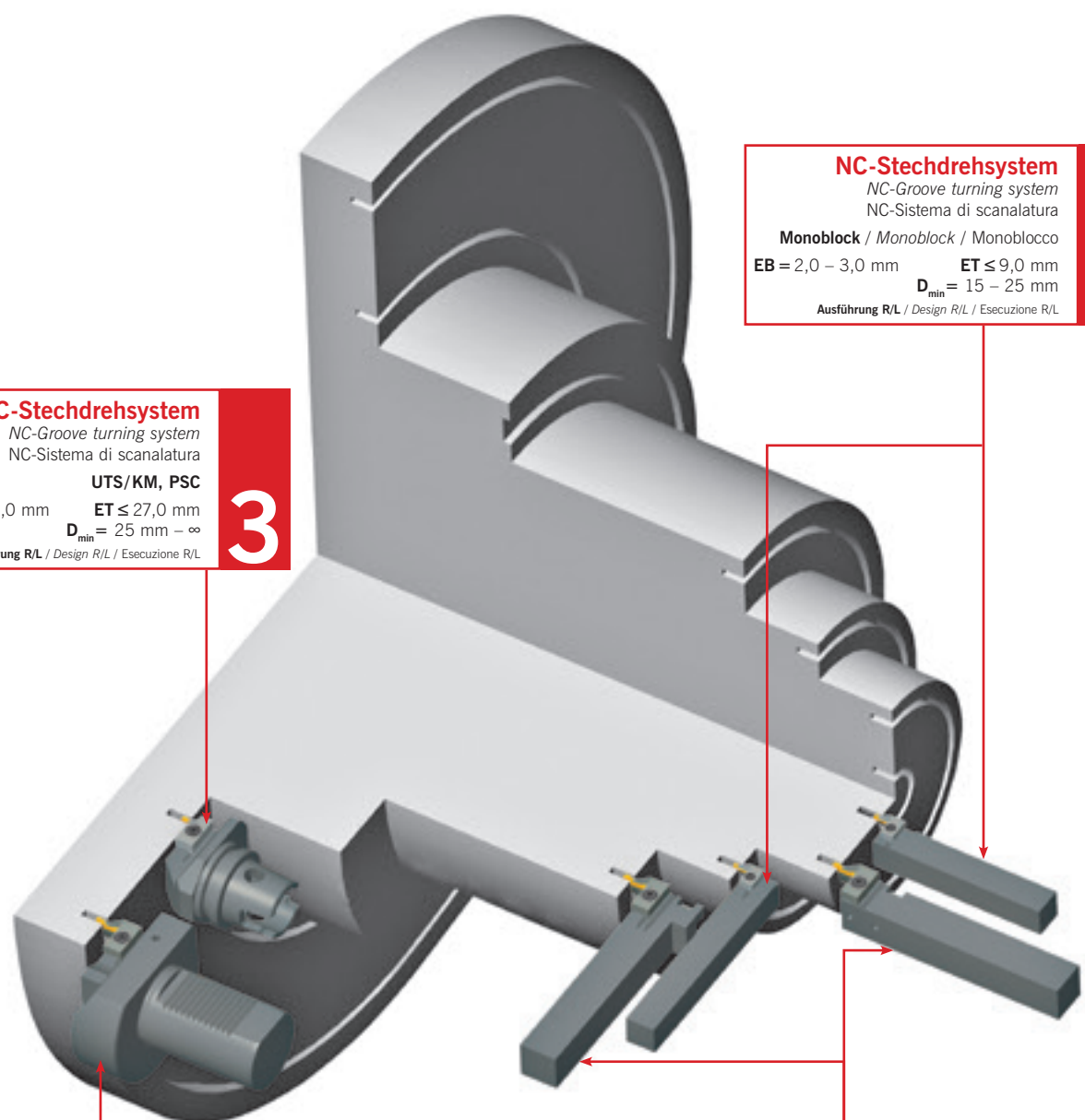

NC-Stechedrehsystem
 NC-Groove turning system
 NC-Sistema di scanalatura

Monoblock / Monoblock / Monoblocco

EB = 2,0 – 3,0 mm ET ≤ 9,0 mm
D_{min} = 15 – 25 mm

Ausführung R/L / Design R/L / Esecuzione R/L

3

NC-Stechedrehsystem
 NC-Groove turning system
 NC-Sistema di scanalatura

UTS/KM, PSC

EB = 2,0 – 10,0 mm ET ≤ 27,0 mm
D_{min} = 25 mm – ∞

Ausführung R/L / Design R/L / Esecuzione R/L

3

NC-Stechedrehsystem
 NC-Groove turning system
 NC-Sistema di scanalatura

**gerade/abgesetzt / straight/cranked /
 dritto/inclinato**

EB = 2,0 – 10,0 mm ET ≤ 40,5 mm
D_{min} = 25 mm – ∞

Ausführung R/L / Design R/L / Esecuzione R/L

3

NC-Stechedrehsystem
 NC-Groove turning system
 NC-Sistema di scanalatura

VDI

EB = 3,0 – 10,0 mm ET ≤ 40,0 mm
D_{min} = 50 mm – ∞

Ausführung R/L / Design R/L / Esecuzione R/L

3

Ohne Abbildung / Not shown / Non illustrato

Clip-Groove® Axial

EB = 1,0 – 2,5 mm
ET = 1,5 – 3,0 mm
D_{min} = 10 mm

Ausführung R/L / Design R/L / Esecuzione R/L

5

Axial-Stechedrehen – Kontra

Axial groove turning – Contra

Scanalatura di copiatura assiale – Kontra

0

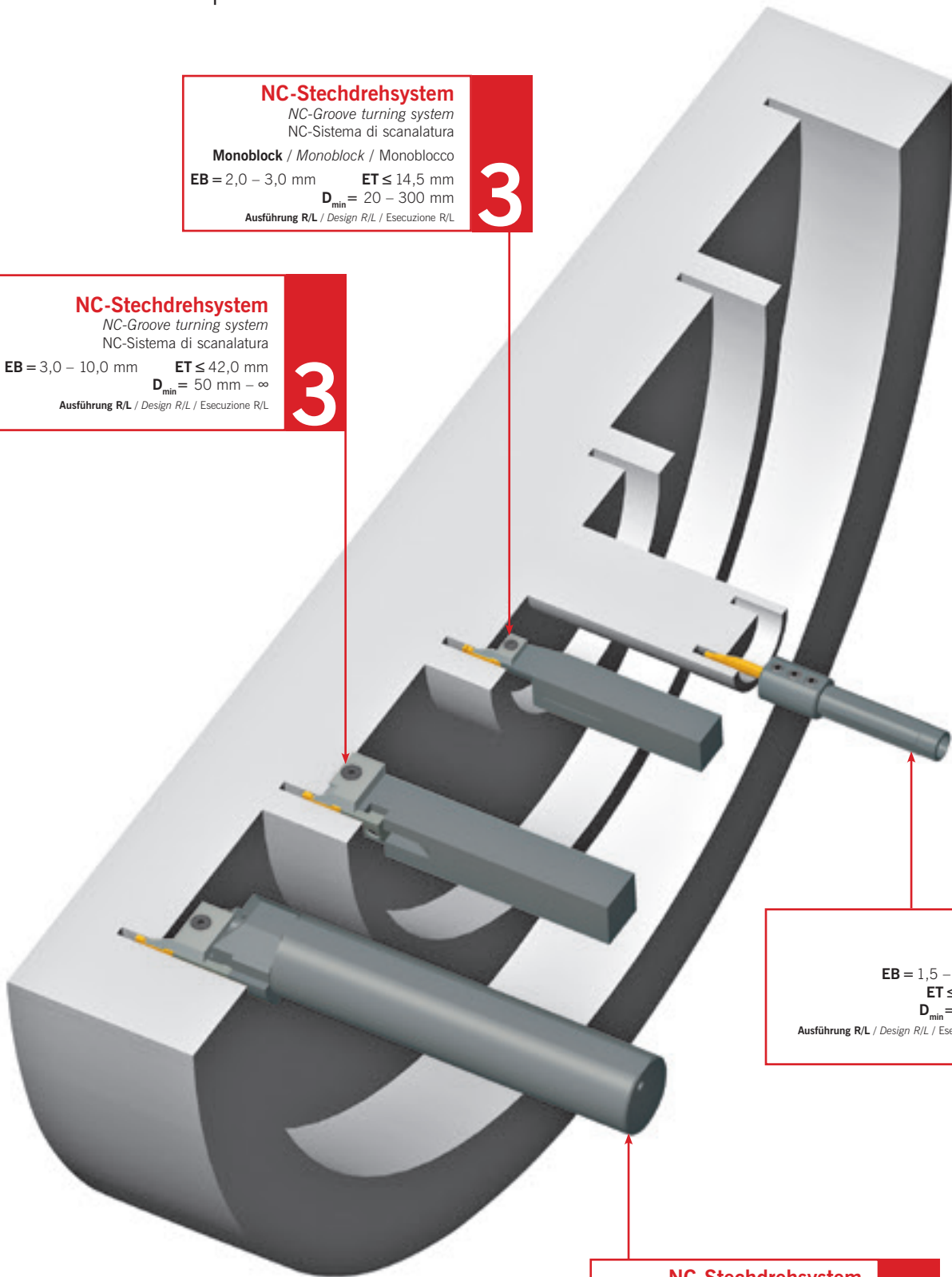

NC-Stechedrehesystem
NC-Groove turning system
NC-Sistema di scanalatura
Monoblock / Monoblock / Monoblocco
EB = 2,0 – 3,0 mm ET ≤ 14,5 mm
D_{min} = 20 – 300 mm
Ausführung R/L / Design R/L / Esecuzione R/L **3**

NC-Stechedrehesystem
NC-Groove turning system
NC-Sistema di scanalatura
EB = 3,0 – 10,0 mm ET ≤ 42,0 mm
D_{min} = 50 mm – ∞
Ausführung R/L / Design R/L / Esecuzione R/L **3**

SAV
EB = 1,5 – 4,0 mm
ET ≤ 40 mm
D_{min} = 10 mm
Ausführung R/L / Design R/L / Esecuzione R/L **7**

NC-Stechedrehesystem
NC-Groove turning system
NC-Sistema di scanalatura
Bohrstange / Boring bar / Bareno
EB = 3,0 – 10,0 mm ET ≤ 42,0 mm
D_{min} = 50 mm – ∞
Ausführung R/L / Design R/L / Esecuzione R/L **3**

Innenstechdrehen

Internal groove turning

Scanalatura di copiatura interna

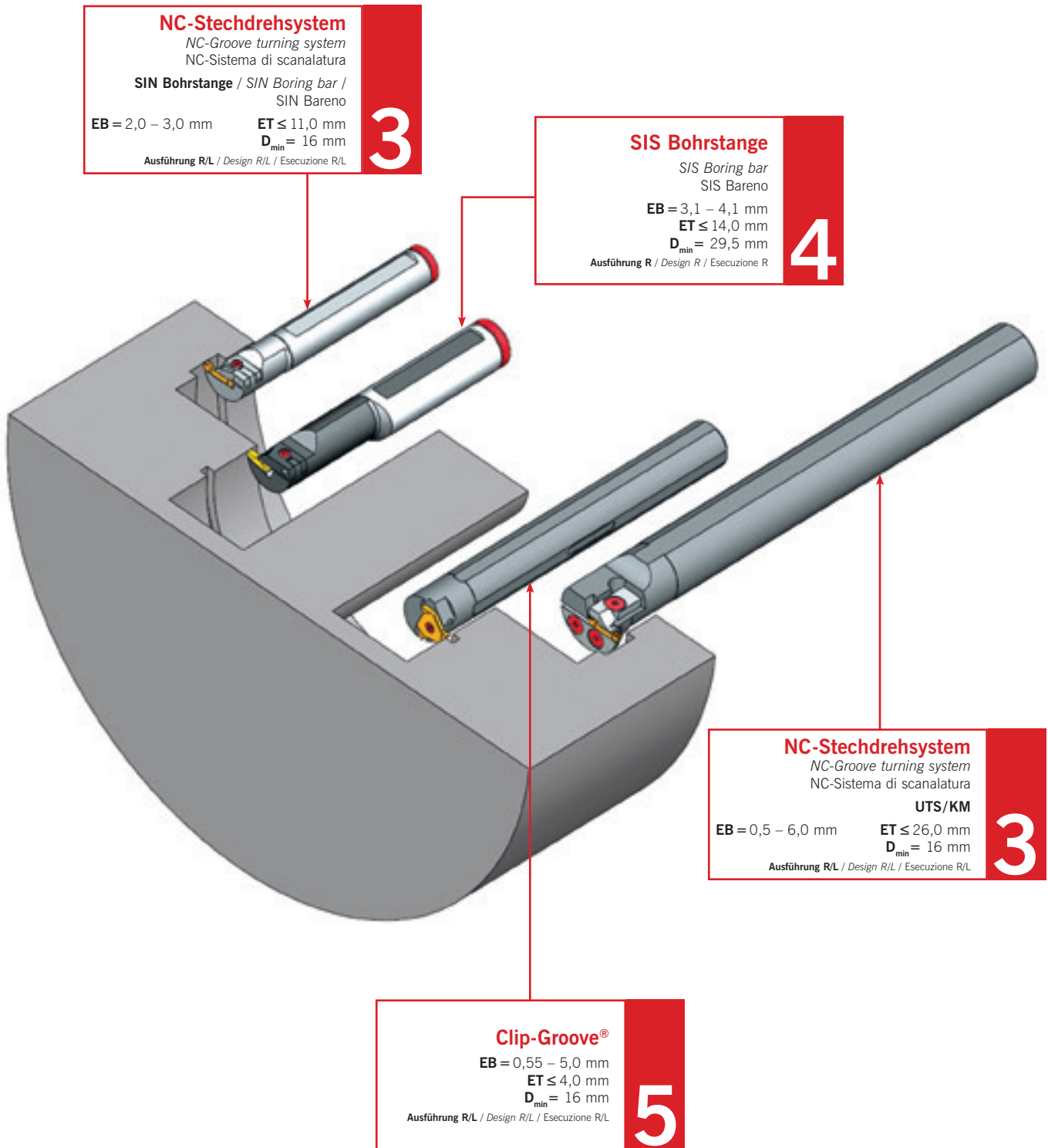

NC-Stechedrehsystem
 NC-Groove turning system
 NC-Sistema di scanalatura

SIN Bohrstange / SIN Boring bar / SIN Bareno

EB = 2,0 – 3,0 mm ET ≤ 11,0 mm
 D_{min} = 16 mm

Ausführung R/L / Design R/L / Esecuzione R/L

3

SIS Bohrstange
 SIS Boring bar
 SIS Bareno

EB = 3,1 – 4,1 mm
 ET ≤ 14,0 mm
 D_{min} = 29,5 mm

Ausführung R / Design R / Esecuzione R

4

NC-Stechedrehsystem
 NC-Groove turning system
 NC-Sistema di scanalatura

UTS/KM

EB = 0,5 – 6,0 mm ET ≤ 26,0 mm
 D_{min} = 16 mm

Ausführung R/L / Design R/L / Esecuzione R/L

3

Clip-Groove®

EB = 0,55 – 5,0 mm
 ET ≤ 4,0 mm
 D_{min} = 16 mm

Ausführung R/L / Design R/L / Esecuzione R/L

5

Werkzeuge zur Innenbearbeitung – AMS ARNO®-Mini-System

Tools for internal machining – AMS ARNO®-Mini-System

Utensili per la lavorazione interna – AMS ARNO®-Mini-System

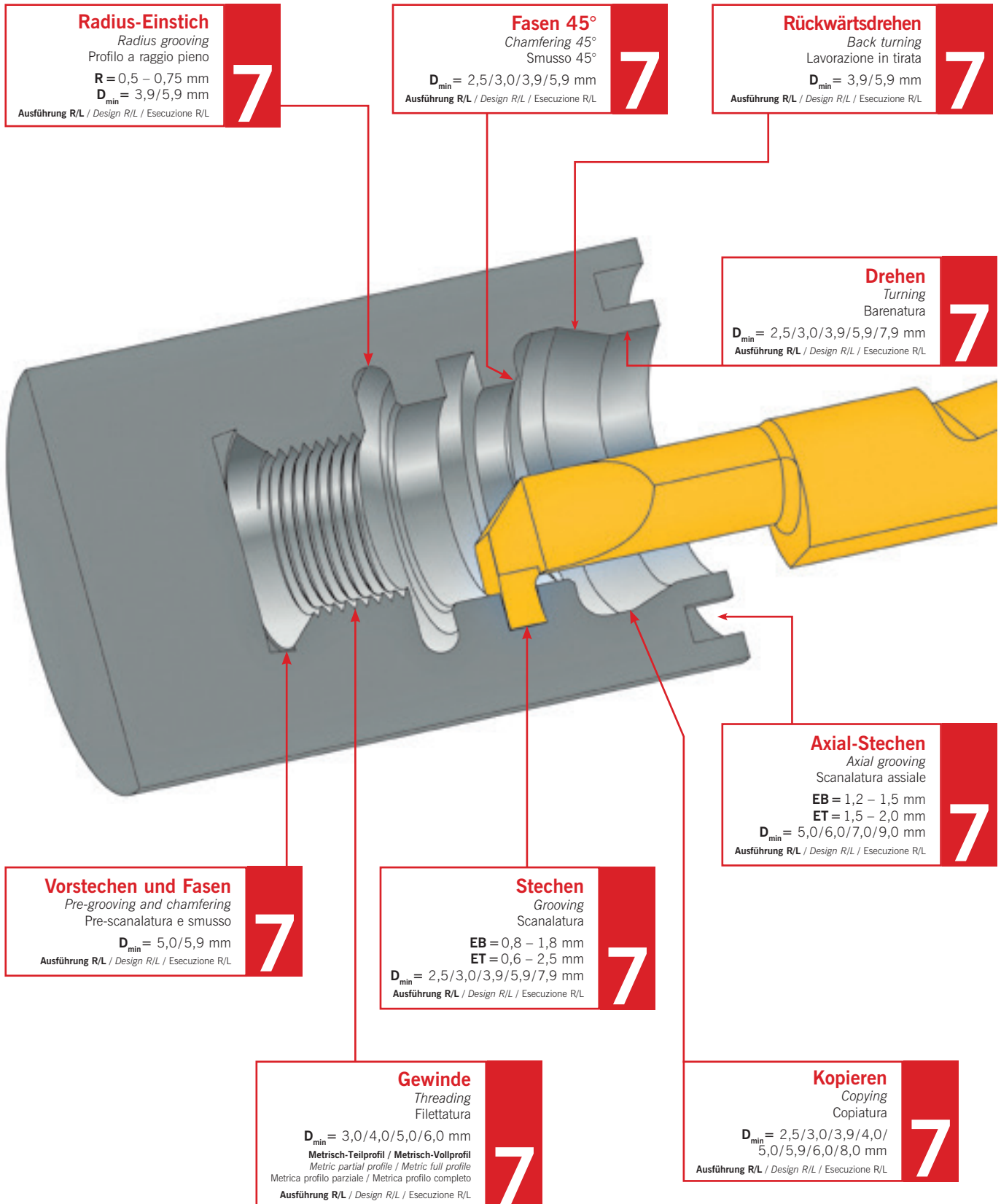

Werkzeuge zur Innenbearbeitung – SIM – Bohrstangen

Tools for internal machining – SIM – Boring bars

Utensili per la lavorazione interna – SIM – Barenì

Radius-Einstich
Radius grooving
 Profilo a raggio pieno
R = 0,4 – 2,0 mm
D_{min} = 9,7/11,7/13,7/15,7 mm
 Ausführung R/L / Design R/L / Esecuzione R/L

Seegering DIN 471/472
Cir-clip grooving DIN 471/472
 Sedi Seeger DIN 471/472
EB = 0,73 – 1,69 mm
D_{min} = 9,7/11,7/13,7/15,7 mm
 Ausführung R/L / Design R/L / Esecuzione R/L

Rückwärtsdrehen
Back turning
 Lavorazione in tirata
D_{min} = 9,7/11,7/13,7/15,7 mm
 Ausführung R/L / Design R/L / Esecuzione R/L

Gewinde
Threading
 Filettatura
D_{min} = 6,7/8,0/8,2/8,7/
 10,7/13,7/15,7 mm
Metrisch / Rohrgewinde / Trapezgewinde
Metric / Whitworth pipe thread / Trapezoidal
 Metrica / Filettatura Whitworth / Filettatura Trapezoidale
 Ausführung R/L / Design R/L / Esecuzione R/L

Kopieren 15°/30°/45°
Copying 15°/30°/45°
 Copiatura 15°/30°/45°
D_{min} = (6,7)/9,7/11,7/13,7/15,7 mm
 Ausführung R/L / Design R/L / Esecuzione R/L

Vorstechen und Fasen
Pre-grooving and chamfering
 Pre-scanalatura e smusso
D_{min} = 9,7/11,7/13,7/15,7 mm
 Ausführung R/L / Design R/L / Esecuzione R/L

Fasen 45°
Chamfering 45°
 Smusso 45°
D_{min} = 6,7/9,7/11,7/13,7/15,7 mm
 Ausführung R/L / Design R/L / Esecuzione R/L

Einstechen
Grooving
 Gole
EB = 0,5 – 4,0 mm
ET = 1,0 – 4,5 mm
D_{min} = 6,7/7,7/7,8/9,7/
 11,7/13,7/15,7 mm
 Ausführung R/L / Design R/L / Esecuzione R/L



**Sonderlösungen –
genau auf Sie zugeschnitten.**

*Special solutions especially
for your application!*

Soluzioni speciali –
su misura per voi.

**Sie haben eine Aufgabe –
wir haben die Lösung.**

Nutzen Sie unsere langjährige Erfahrung im Bereich der Sonderwerkzeuge und arbeiten Sie mit ARNO-Werkzeugen in Zukunft effektiver und kostengünstiger.

Ganz egal ob Sonderschneideinsätze oder komplexe Kombi-Werkzeuge – wir fertigen Ihnen flexibel, schnell und präzise nahezu jeden Wunsch.

*You have an application –
we have a solution.*

Take advantage of our many years' experience in special solutions and in future benefit from more efficient and cost effective ARNO tooling.

Whether it is special inserts or complex combination tools – we are able to offer nearly any solutions.

**Hai un problema –
chiedici la nostra soluzione.**

La nostra pluriennale esperienza nell'ambito delle lavorazioni meccaniche ci rende capaci di offrire qualsiasi soluzione di lavorazione nell'ambito delle nostre competenze specifiche.

Sia per singoli inserti o utensili e sia per complete combinazioni di utensili.

Un servizio veloce, flessibile e preciso per ogni esigenza.

Weitere Informationen finden Sie unter:

For more information see:

Altre informazioni su:

www.arno.de

Über uns		Seite	20
Service weltweit			25
ARNO-Stechsysteme			26
1 SA-Stechsystem	Ein- und Abstechsystem		
• Systemvorstellung			46 – 55
• Monoblockhalter	Ein- und Abstechen	EB 1,5 – 10,0 mm	ET _{max} 3,0 – 37,5 mm
• Stechklingen	Ein- und Abstechen	EB 1,5 – 4,0 mm	ET _{max} 10,0 – 52,5 mm
• Module	Ein- und Abstechen	EB 1,5 – 6,0 mm	ET _{max} 6,0 – 70,0 mm
• Schneideinsätze			129 – 141
2 SE-Stechsystem	Ein- und Abstechsystem		
• Systemvorstellung			154 – 159
• Monoblockhalter	Ein- und Abstechen	EB 2,0 – 6,0 mm	ET _{max} 12,0 – 21,0 mm
• Schneideinsätze			184 – 187
3 NC-Stechdrehsystem	Präzisions-Stechdrehsystem		
• Systemvorstellung			200 – 201
• Grundhalter – Außenbearbeitung	Präzisions-Außenstechdrehen	EB 0,5 – 10,0 mm	ET _{max} 0,5 – 40,5 mm
• SAN Monoblockhalter	Präzisions-Außenstechdrehen	EB 3,0 – 6,0 mm	ET _{max} 17,0 – 27,0 mm
• Grundhalter – Innenbearbeitung	Präzisions-Innenstechdrehen	EB 0,5 – 6,0 mm	D _{min} 16,0 – 81,0 mm
• SIN Bohrstangen	Präzisions-Innenstechdrehen	EB 2,0 und 3,0 mm	D _{min} 16,0 – 32,0 mm
• Schneideinsätze			247 – 259
4 SHORT-CUT	Stechdrehsystem		
• Systemvorstellung			280 – 281
• Monoblockhalter	Außenstechdrehen	EB 2,1 – 10,1 mm	ET 4,0 – 27,0 mm
• SIS Bohrstangen	Innenstechdrehen	EB 3,1 und 4,1 mm	D _{min} 29,5 – 47,5 mm
• Schneideinsätze			292 – 295
5 CLIP-GROOVE	Einstechsystem		
• Systemvorstellung			306 – 307
• Monoblockhalter	Außeneinstechen	EB 0,55 – 5,0 mm	ET _{max} 10,0 mm
• Bohrstangen	Inneneinstechen	ET _{max} 4,0 mm	D _{min} 16,0 – 37,0 mm
• Schneideinsätze			318 – 328
6 PROFIL-CUT	Formeinstechsystem		
• Systemvorstellung			338 – 339
• Monoblockhalter	Formeinstechen	EB 12,0 – 25,0 mm	ET _{max} 7,5 – 12,0 mm
• Schneideinsätze			344 – 345
7 AMS ARNO®-Mini-System	Innenbearbeitungssystem		
• Systemvorstellung			352 – 353
• Klemmhalter und Schneideinsätze		D _{min} 0,7 mm	354 – 398
8 SIM	Innenbearbeitungssystem		
• Systemvorstellung			410 – 411
• Bohrstangen und Schneideinsätze		D _{min} 6,7 mm	412 – 433
9 Werkzeughalter und Direktaufnahmen	Maschinen angepasste Spanneinheiten		
• Systemvorstellung			446 – 448
• Werkzeugaufnahmen			458 – 477
• Abstechhalter			478 – 515
• Direktaufnahmen			516 – 575
i Informationen			
• Vergleichstabellen			604 – 621
• Verschleiß und Abhilfe			622 – 623
• Anwendungshinweise			624 – 632
A Alphanumerischer Index			634 – 637



0
1
2
3
4
5
6
7
8
9
i
A

	Page
About us.....	20
Service worldwide	25
Grooving Systems.....	26
1 SA-Grooving system Grooving and parting system	
• Introduction	46 – 55
• Monoblock holders Grooving and parting EB 1,5 – 10,0 mm ET _{max} 3,0 – 37,5 mm	56 – 93
• Blades Grooving and parting EB 1,5 – 4,0 mm ET _{max} 10,0 – 52,5 mm	94 – 113
• Modules Grooving and parting EB 1,5 – 6,0 mm ET _{max} 6,0 – 70,0 mm	114 – 128
• Inserts	129 – 141
2 SE-Grooving system Grooving and parting system	
• Introduction	154 – 159
• Monoblock holders Grooving and parting EB 2,0 – 6,0 mm ET _{max} 12,0 – 21,0 mm	160 – 183
• Inserts	184 – 187
3 NC-Groove turning system Precision groove turning system	
• Introduction	200 – 201
• Basic holders – External machining Precision external groove turning EB 0,5 – 10,0 mm ET _{max} 0,5 – 40,5 mm	202 – 235
• SAN Monoblock holders Precision external groove turning EB 3,0 – 6,0 mm ET _{max} 17,0 – 27,0 mm	236
• Basic holders – Internal machining Precision internal groove turning EB 0,5 – 6,0 mm D _{min} 16,0 – 81,0 mm	237 – 245
• SIN Boring bars Precision internal groove turning EB 2,0 und 3,0 mm D _{min} 16,0 – 32,0 mm	246
• Inserts	247 – 259
4 SHORT-CUT Groove turning system	
• Introduction	280 – 281
• Monoblock holders External groove turning EB 2,1 – 10,1 mm ET 4,0 – 27,0 mm	282 – 287
• SIS Boring bars Internal groove turning EB 3,1 und 4,1 mm D _{min} 29,5 – 47,5 mm	288
• Inserts	292 – 295
5 CLIP-GROOVE Grooving system	
• Introduction	306 – 307
• Monoblock holders External grooving EB 0,55 – 5,0 mm ET _{max} 10,0 mm	311 – 313
• Boring bars Internal grooving ET _{max} 4,0 mm D _{min} 16,0 – 37,0 mm	314
• Inserts	315 – 328
6 PROFIL-CUT Form groove system	
• Introduction	338 – 339
• Monoblock holders Form grooves EB 12,0 – 25,0 mm ET _{max} 7,5 – 12,0 mm	340 – 343
• Inserts	344 – 345
7 AMS ARNO®-Mini-System Internal machining system	
• Introduction	352 – 353
• Holders and inserts D _{min} 0,7 mm	354 – 398
8 SIM Internal machining system	
• Introduction	410 – 411
• Boring bars and inserts D _{min} 6,7 mm	412 – 433
9 Flange mounted holders Machine specific units	
• Introduction	446 – 448
• KMH-holders	458 – 477
• Part-off holders	478 – 515
• Flange mounted holders	516 – 575
i Information	
• Material – Cross Reference	604 – 621
• Wear and its solution	622 – 623
• Application reference	624 – 632
A Alphanumerical index.....	634 – 637

					Pagina
Chi siamo					20
Nel mondo					25
Sistema di scanalatura					26
1 SA-Sistema di troncatura Sistema di troncatura e scanalatura					
• Caratteristiche del sistema					46 – 55
• Utensili monoblocco	Troncatura e scanalatura	EB 1,5 – 10,0 mm	ET _{max} 3,0 – 37,5 mm		56 – 93
• Lame da taglio	Troncatura e scanalatura	EB 1,5 – 4,0 mm	ET _{max} 10,0 – 52,5 mm		94 – 113
• Moduli	Troncatura e scanalatura	EB 1,5 – 6,0 mm	ET _{max} 6,0 – 70,0 mm		114 – 128
• Inserti					129 – 141
2 SE-Sistema di troncatura Sistema di troncatura e scanalatura					
• Caratteristiche del sistema					154 – 159
• Utensili monoblocco	Troncatura e scanalatura	EB 2,0 – 6,0 mm	ET _{max} 12,0 – 21,0 mm		160 – 183
• Inserti					184 – 187
3 NC-Sistema di scanalatura Sistema di scanalatura e copiatura modulare di precisione					
• Caratteristiche del sistema					200 – 201
• Corpo utensili – Steli per lavorazione esterna	Sistema di scanalatura e copiatura modulare esterna di precisione	EB 0,5 – 10,0 mm	ET _{max} 0,5 – 40,5 mm		202 – 235
• SAN Utensili monoblocco		EB 3,0 – 6,0 mm	ET _{max} 17,0 – 27,0 mm		236
• Corpo utensili – Steli per lavorazione interna	Sistema di scanalatura e copiatura modulare interna di precisione	EB 0,5 – 6,0 mm	D _{min} 16,0 – 81,0 mm		237 – 245
• SIN Bareni		EB 2,0 und 3,0 mm	D _{min} 16,0 – 32,0 mm		246
• Inserti					247 – 259
4 SHORT-CUT Sistema di tornitura e scanalatura					
• Caratteristiche del sistema					280 – 281
• Utensili monoblocco	Sistema di tornitura e scanalatura esterna	EB 2,1 – 10,1 mm	ET 4,0 – 27,0 mm		282 – 287
• SIS Bareni	Sistema di tornitura e scanalatura interna	EB 3,1 und 4,1 mm	D _{min} 29,5 – 47,5 mm		288
• Inserti					292 – 295
5 CLIP-GROOVE Sistema di scanalatura					
• Caratteristiche del sistema					306 – 307
• Utensili monoblocco	Scanalatura esterna	EB 0,55 – 5,0 mm	ET _{max} 10,0 mm		311 – 313
• Bareni	Scanalatura interna	ET _{max} 4,0 mm	D _{min} 16,0 – 37,0 mm		314
• Inserti					315 – 328
6 PROFIL-CUT Sistema di gole a forma					
• Caratteristiche del sistema					338 – 339
• Monoblock holders	Gole a forma	EB 12,0 – 25,0 mm	ET _{max} 7,5 – 12,0 mm		340 – 343
• Inserti					344 – 345
7 AMS ARNO®-Mini-Sistema Sistema di lavorazione interna					
• Caratteristiche del sistema					352 – 353
• Adattatori e inserti		D _{min} 0,7 mm			354 – 398
8 SIM Sistema di lavorazione interna					
• Caratteristiche del sistema					410 – 411
• Bareni e inserti		D _{min} 6,7 mm			412 – 433
9 Attacchi base Specifica costruttore					
• Caratteristiche del sistema					446 – 448
• Adattatori KMH					458 – 477
• Adattatori di troncatura					478 – 515
• Attacchi base					516 – 575
i Informazioni					
• Tabelle comparative					604 – 621
• Usura e soluzioni					622 – 623
• Suggerimenti tecnici					624 – 632
A Indice alfanumerico					634 – 637

ARNO[®]

WERKZEUGE

0



Tradition in Präzision.

„Vom lokalen Familienunternehmen zum weltweiten Vertrieb.“

1941 gründet Emil Arnold den „Lehrenbau“ in Esslingen am Neckar. Anfänglich fertigt er hauptsächlich Messvorrichtungen und Prüflöhren. Schon damals hat er sich durch die hervorragende Qualität seiner Produkte einen Namen gemacht. Besonders, weil er auf die Kunden eingeht und deren Wünsche präzise erfüllt.

Zusammen mit seinem Sohn Karl-Heinz Arnold steckt er viel Herzblut in die Firma und ist immer offen für neue Entwicklungen. Er hat die Vision, mit seinen Werkzeugen in den Fertigungen aller Länder und Branchen vertreten zu sein. 1962 gründet sein Sohn die Firma Karl-Heinz Arnold GmbH, die sich fortan unter dem Namen ARNO®-Werkzeuge vor allem dem Vertrieb von Hartmetallwerkzeugen widmet. Zusammen beschäftigen sich die beiden Firmen konsequent mit Marktlücken, haben immer die Wünsche der Kunden im Auge.

1987 tritt Klaus-Michael Arnold in die Firma ein und wird 1992 Geschäftsführer. Zusammen mit Josef Storf, 2002 zum Geschäftsführer ernannt, werden im Sinne des Firmengründers das Produktsortiment ständig ausgebaut und neue Vertriebswege gesucht. 2004 ist es dann soweit: Im Ausland, bereits über Vertriebspartner etabliert, wird die erste Niederlassung in England gegründet. Bald darauf folgen Italien, Russland und die USA. 2014 eröffnet schließlich die Niederlassung in Singapur, um auch den ost-asiatischen Markt zu erobern. Durch die stetige Weiterentwicklung des Programms und dank sehr gutem Serviceangebot ist ARNO®-Werkzeuge bis heute weltweit anerkannt für seine hochpräzisen Zerspanungswerkzeuge.

ARNO®

WERKZEUGE

0



Stechen

Ob Radial- oder Axial-Stechdrehen, Abstechen, Langdrehen oder Innenstechdrehen – Sie finden bei ARNO®-Werkzeuge für jede Anwendung das optimale Stechwerkzeug.



Bohren

Von 1 mm bis 114 mm Durchmesser sind Bohrer mit austauschbaren Schneidplatten und VHM-Spiralbohrer zur Innen- und Außenbearbeitung in unserem Produktportfolio vertreten.



Drehen

ARNO®-Werkzeuge bietet zuverlässige Werkzeuge mit den unterschiedlichsten Wendeschneidplatten für höchste Ansprüche in der Innen- und Außenbearbeitung sowie zum Gewindedrehen.

Stärke durch Erfahrung, Kompetenz und Entwicklung.

„Für die Zukunft brauchen Sie einen Partner mit Zukunft.“

Durch intensive Zusammenarbeit innerhalb und außerhalb der Firma sind wir in der Lage, individuelle Kundenwünsche mit unserem Know-how zu erfüllen. Dabei entwickeln wir ständig neue Sonderwerkzeuge, um diese dann später auch in unser Standardprogramm aufzunehmen.

Neue Werkstoffe, ebenso wie die Anforderungen nach ständig steigenden Bearbeitungsgeschwindigkeiten, fordern uns, zu forschen und neue Produkte auf den Markt zu bringen. Es gilt, modulare Werkzeugsysteme anzufertigen, die individuell für unterschiedlichste Einsatzbereiche angepasst werden. Unsere leistungsfähige und trotzdem wirtschaftliche Produktpalette beinhaltet vom Bohrsystem über Stechwerkzeuge, Fräsköpfe und einer Vielfalt an Wendeschneidplatten (nicht nur zum Drehen) auch Werkzeugaufnahmen und Werkzeugautomaten.

Neben qualitativ einwandfreien Produkten sind fachliche Beratung und Betreuung für uns selbstverständlich. **Unser kompetentes Team erfüllt Ihre Wünsche und hilft Ihnen mit Service nach Maß auch nach Ihrer Kaufentscheidung.**



Fräsen

Planfräser, Eckfräser, Fasfräser, Fräser mit runden oder eckigen Wendeschneidplatten, Schrufffräser. Auch für Ihre Anwendung finden Sie einen passenden Fräser.



Werkzeugautomaten

Sichere Werkzeugaufbewahrung, -verfolgung und -entnahme garantiert Ihnen der flexibel konfigurierbare StoreManager.



Werkstückspannung

NC-Schraubstöcke in einfacher oder doppelter Ausführung für perfekt gespannte Werkstücke in der modernen Fertigung.

Service nach Maß.

Individuelle Sonderlösungen

Mit unserem breiten Produktsortiment sind wir bestens für nahezu jede Herausforderung gerüstet. **Sie haben dennoch eine ganz besondere Aufgabe, die besonderes Werkzeug verlangt?** Dann wenden Sie sich an uns, denn ARNO produziert auch kundenorientierte Sonderlösungen – optimal auf Ihre Bedürfnisse zugeschnitten. Das garantiert perfekte Ergebnisse ohne Einschränkungen.

Lieferung über Nacht

Für Sie muss es richtig schnell gehen? Kein Problem, denn wenn Sie die **Bestellung Ihrer Produkte bis 18 Uhr (freitags bis 16 Uhr) abschließen, steht am nächsten Tag ein Fahrer vor Ihrer Tür.** Dieses Angebot gilt nur für unsere Lagerware, denn um die Qualität unserer individuellen Sonderlösungen zu garantieren, nehmen wir uns für diese auch etwas mehr Zeit.

Alles unter einem Dach

Die hohe Qualität unserer Produkte basiert nicht zuletzt darauf, dass **die Konstruktion, die Produktion und der Vertrieb bei ARNO auf einem Gelände stattfinden.** Das ermöglicht uns ausgiebige Testverfahren, schnellere Reaktionszeiten, bessere Kontrolle und – einen günstigeren Preis.

Großes Außendienst-Team

Wir lassen Sie mit unseren Produkten nicht allein. Das ARNO-Außendienst-Team besucht Sie regelmäßig und unterstützt Sie mit umfassendem Produktwissen.

Unsere Anwendungstechniker

Sie haben ein Problem in Ihrer Zerspanung festgestellt oder haben eine Frage, die Sie nur vor Ort klären können? Unsere Anwendungstechniker besuchen Sie in Ihrem Werk und unterstützen Sie bei Technikfragen.

Unsere Bestell-Hotline

Sie haben die Möglichkeit in nahezu allen Ländern der Welt einen unserer ARNO-Mitarbeiter zu erreichen. Profitieren Sie von unserer zuverlässigen und kompetenten Fachberatung am Telefon. Für komplexere Fragen stehen Ihnen persönliche Ansprechpartner zur Verfügung.

Weltweit im Einsatz – Ihr Service direkt vor Ort.

ARNO®-Werkzeuge finden Sie überall auf der Welt. Uns ist es wichtig, nicht nur zentral von einem Punkt aus unsere Kunden zu betreuen. Vielmehr möchten wir Ihnen als Kunden einen lokalen Service bieten. Mit Vertriebspartnern und Niederlassungen in vielen Ländern der Welt sind wir für Sie einfach zu erreichen.

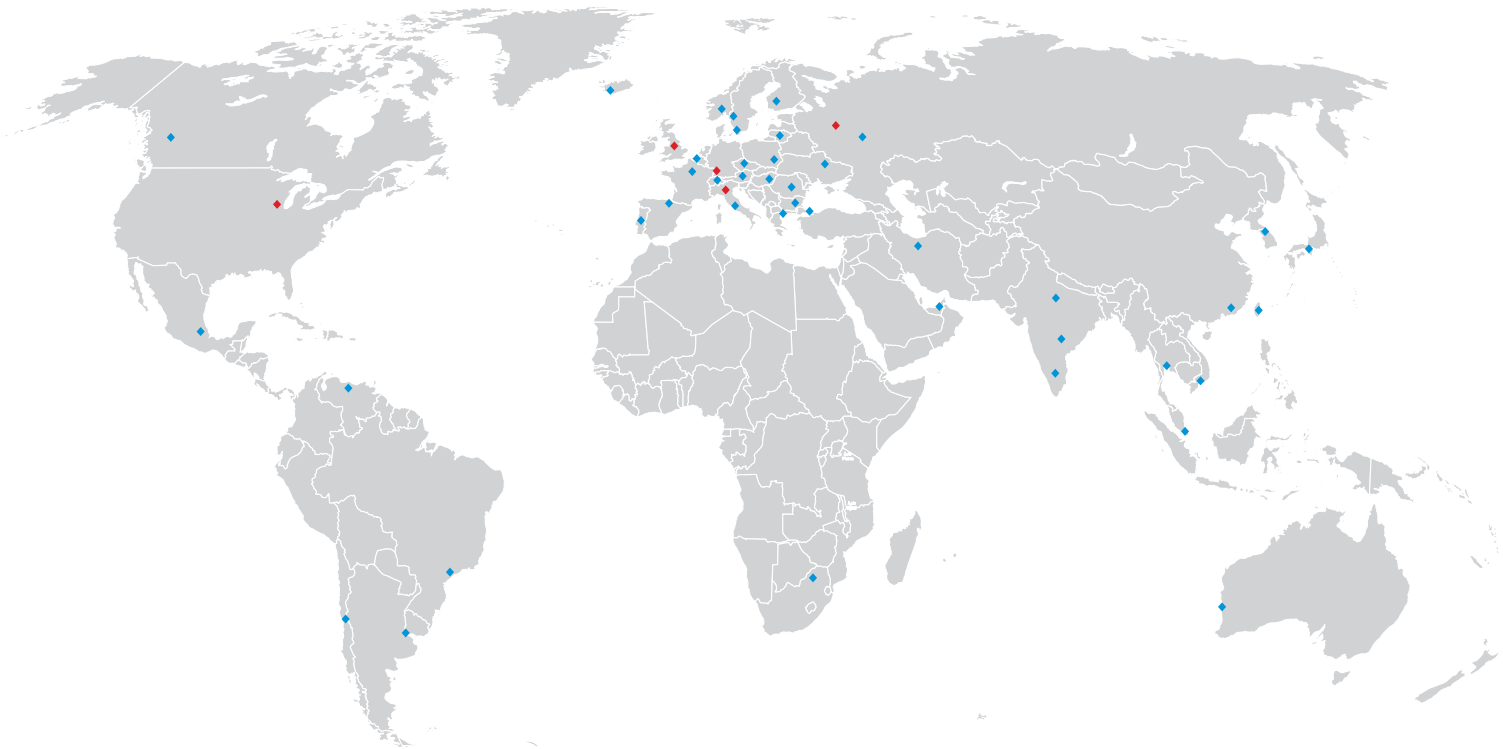

◆ Niederlassungen

◆ Vertriebspartner

Karl-Heinz Arnold GmbH
Karlsbader Str. 4
73760 Ostfildern

Tel.: +49 (0) 711/34 802-0
Fax: +49 (0) 711/34 802-130
bestellung@arno.de
anfrage@arno.de
www.arno.de

ARNO (UK) Limited | Unit 9, 10 & 11, Sugnall Business Centre | Sugnall, Eccleshall | Staffordshire | ST21 6NF
☎ +44 01785 850 072 | 📠 +44 01785 850 076 | sales@arno.de | www.arno-tools.co.uk

ARNO Italia S.r.l | Via J. F. Kennedy 19 | 20871 Vimercate (MB)
☎ +39 039 68 52 101 | 📠 +39 039 60 83 724 | info@arno-italia.it | www.arno-italia.it

ARNO-Werkzeuge USA LLC | 1101 W. Diggins St. | US-60033 Harvard, Illinois
☎ +1 815 943 4426 | 📠 +1 815 943 7156 | info@arnousa.com | www.arnousa.com

ARNO RU Ltd. | Krassnaja Ul. 38 | RU-600015 Vladimir
☎ / 📠 +7 4922 541125 | 📠 +7 4922 541135 | info@arnoru.ru | www.arnoru.ru

Abstechhalter und Direktaufnahmen

Höheneinstellbare Abstechhalter zur Aufnahme von MSA-Modulen und KSA-Abstechklingen.

ab Seite 445

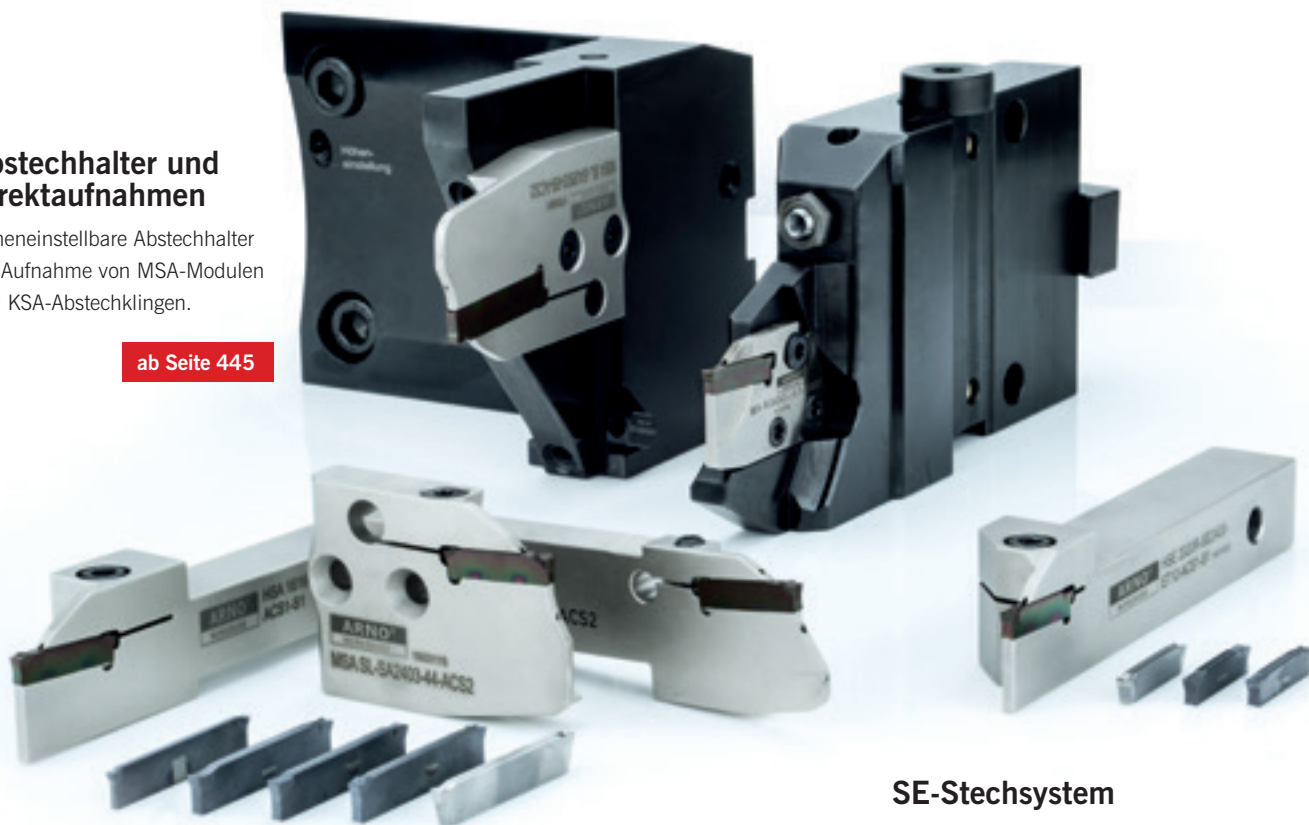

SA-Stechnsystem

Lösungen für das Einstechen und Abstechen bis Ø 140 mm vereint in verschiedenen Werkzeugausführungen.

ab Seite 45



ab Seite 199



ab Seite 279



ab Seite 305

SE-Stechnsystem

Monoblockhalter für zweischneidige Wendeschneidplatten zum Ein- und Abstechen und Kopierdrehen.

ab Seite 153

NC-Stechnsystem

Universal Stechnsystem für die Außen- und Innenbearbeitung beim Radialen, Axialen und Kontra Stechen.

SHORT-CUT

Der „Robuste“ für die grobe Zerspangung.

CLIP-GROOVE

Einstechsystem mit dreischneidiger Schneidplatte für die radiale oder axiale Bearbeitung.

Lassen Sie nie im Stich. ARNO-Stechnsysteme.

Profitieren Sie von einmaliger Vielseitigkeit:

Mit den modularen ARNO-Stechnsystemen entstehen aus nur einem Grundhalter verschiedenste Werkzeugvarianten – nur durch einfaches Austauschen der Unterstützplatte und Klemme. Dank der hohen Stabilität unserer Stechnwerkzeuge ist die Zerspanung und damit auch Verbundoperationen in alle drei Hauptschnittrichtungen möglich.

Mit den präzisionsgeschliffenen, zwei- bzw. dreischneidigen Schneideinsätzen in unterschiedlichsten Geometrien und Sorten haben Sie das optimale Werkzeug für jedes Ihrer Projekte.

Verschaffen Sie sich einen Überblick über unsere ARNO-Stechnsysteme.



ab Seite 337

PROFIL-CUT

Formeinstichsystem zur Eigenprofilierung der Schneidplatte.



ab Seite 351

ARNO®-Mini-System

AMS ist ein modulares System zur flexiblen Bohrungsbearbeitung ab Durchmesser 0,7 mm mit maximaler Bohrungstiefe bis zu 50 mm.



ab Seite 409

SIM – Bohrstangen

Stirnseitig geschraubtes Werkzeugsystem ab Bohrungsdurchmesser 6,7 mm.

ARNO[®]

WERKZEUGE

0



Tradition in precision.

“Local family business gains global position as a market leader.”

In 1941 Emil Arnold establishes “Lehrenbau” in Esslingen am Neckar. Initially manufacturing mainly measurement jigs and gauges. Because he always gave his customers exactly what they specified he established himself through the high quality of his products.

Together with his son Karl-Heinz Arnold they put their heart and soul into the company and were always open to new developments. He had a vision to be represented with his cutting tools in all industries all over the world. In 1962 his son forms the company Karl-Heinz Arnold GmbH which under the name ARNO®-Werkzeuge began focussing on sales of carbide tools. Both companies were constantly looking for market opportunities with the customers in mind.

In 1987 Klaus-Michael Arnold joined the company and became Managing Director in 1992. In 2002 Josef Storf became joint Managing Director. In the spirit of the company founder, the product portfolio is expanding and the search for new sales channels are constantly being explored. In 2004 ARNO (UK) Ltd becomes the first overseas subsidiary, followed by subsidiaries in Italy, Russia and the USA. In 2014 ARNO eventually opened a subsidiary in Singapore, in order to capture the East-Asian market. Due to the constant developments of the product range and the high level of service provided, today ARNO®-Werkzeuge is globally renowned for its high quality cutting tools.

ARNO[®]

WERKZEUGE

0

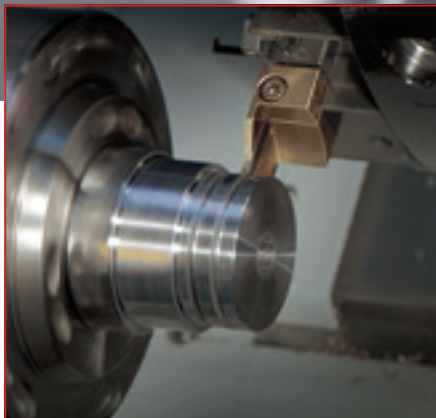

Grooving

Whether it is radial or axial grooving, parting-off, groove turning or internal grooving, you will find the ideal tool from ARNO[®]-Werkzeuge.



Drilling

From 1 mm to 114 mm diameter you will find a solid carbide drill or a solution with indexable inserts from our extensive product range.



Turning

ARNO[®]-Werkzeuge offers reliable tools utilizing various inserts for your most demanding internal or external machining applications as well as tools and inserts for threading.

Strength from experience, competence and development.

“For the future you need a partner with future.”

By working closely with partners inside and outside the company, we are very capable of satisfying individual requirements which often lead to special tooling. These tools are consistently improved and might find their way into our standard portfolio of catalogue tooling later.

New materials and expectations of constant improvement of machine time, motivate us to research and develop new tooling and cutting tool materials. That means developing modular tooling systems that are modified for each individual application. Our high performance but still affordable solutions include our extensive range of drilling systems, grooving systems, milling cutters and our huge range of indexable inserts (not just for turning) as well as tool holding and vending solutions.

Our technical support and advice follow any of our high quality tools. **Our highly competent team will support you with service even after you have made your decision to purchase.**



Milling

Face-mills, square shoulder-mills, chamfer-mills, milling cutters with round inserts, roughing cutters and solid carbide cutters. We have the right cutter for your application.



Tool Vending

Secure storage, monitoring and usage reporting guaranteed with our highly flexible StoreManager solution.



Work Holding Equipment

NC-Machine vice in various executions of number of jaws and widths ensure maximum component clamping for the modern manufacturing.

ARNO[®]

WERKZEUGE

0

Service to Size.

Individual solutions

Despite our wide range of standard tools which will cover a majority of applications, sometimes you may just need a solution for a specific request. ARNO can offer you a special tool which suits your application exactly. A perfect solution without any compromises.

Overnight delivery

When urgency is required ARNO is there to help. Place your order for standard tools by 3:30 PM CET and our tools could be on your machine the next day. For special solutions we need a little longer but then you will also be getting a high quality tool just for your application.

Everything under one roof

The high quality of our products is a result of having R&D, manufacturing and sales at one location. This also gives us the opportunity for testing, offering faster response time, better control and better prices.

Experienced external sales team

You are never left alone with an ARNO product. Our experienced external ARNO sales team is always available for service and support.

Our application engineers

When you have a problem with an application our application engineers will be available to advise you on technical issues.

Ordering hotline

Wherever you may be in the world you will be able to contact an ARNO representative. Take advantage of our competence, we look forward to being of service.

Globally available – Service where you need it.

ARNO®-Werkzeuge is represented worldwide. It is important to us that we can service you where you need it. Our distributors and sister companies are always local and easy to contact.

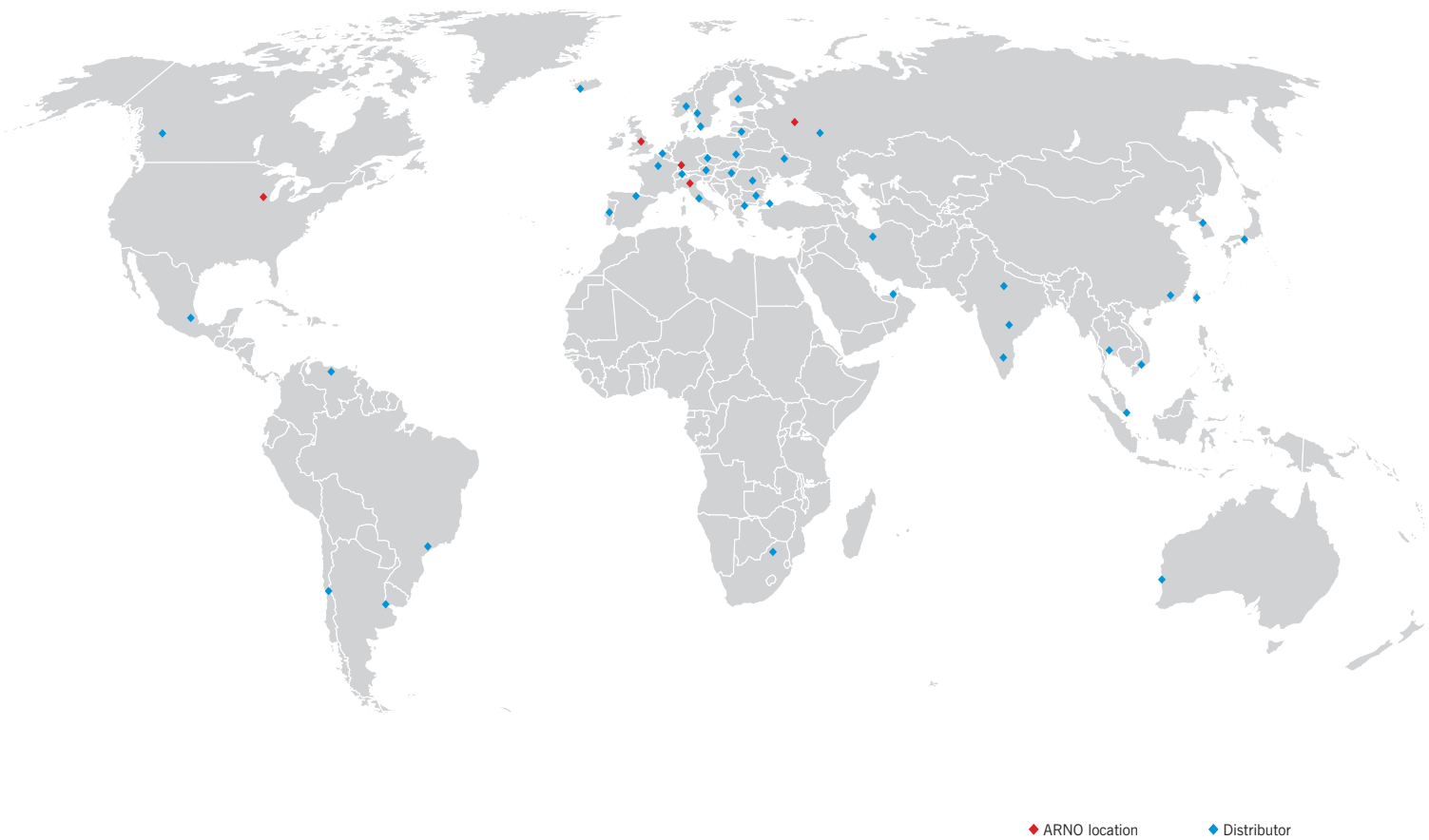

Karl-Heinz Arnold GmbH
Karlsbader Str. 4
73760 Ostfildern

Tel.: +49 (0) 711/34 802-0
Fax: +49 (0) 711/34 802-130
info@arno.de
www.arno.de

ARNO (UK) Limited | Unit 9, 10 & 11, Sugnall Business Centre | Sugnall, Eccleshall | Staffordshire | ST21 6NF
☎ +44 01785 850 072 | 📠 +44 01785 850 076 | sales@arno.de | www.arno-tools.co.uk

ARNO Italia S.r.l | Via J. F. Kennedy 19 | 20871 Vimercate (MB)
☎ +39 039 68 52 101 | 📠 +39 039 60 83 724 | info@arno-italia.it | www.arno-italia.it

ARNO-Werkzeuge USA LLC | 1101 W. Diggins St. | US-60033 Harvard, Illinois
☎ +1 815 943 4426 | 📠 +1 815 943 7156 | info@arnousa.com | www.arnousa.com

ARNO RU Ltd. | Krassnaja Ul. 38 | RU-600015 Vladimir
☎ / 📠 +7 4922 541125 | 📞 +7 4922 541135 | info@arnoru.ru | www.arnoru.ru

Part-off holders and flange mounted holders

Height adjustable holder for MSA-Modules and KSA part-off blades.

Page 445

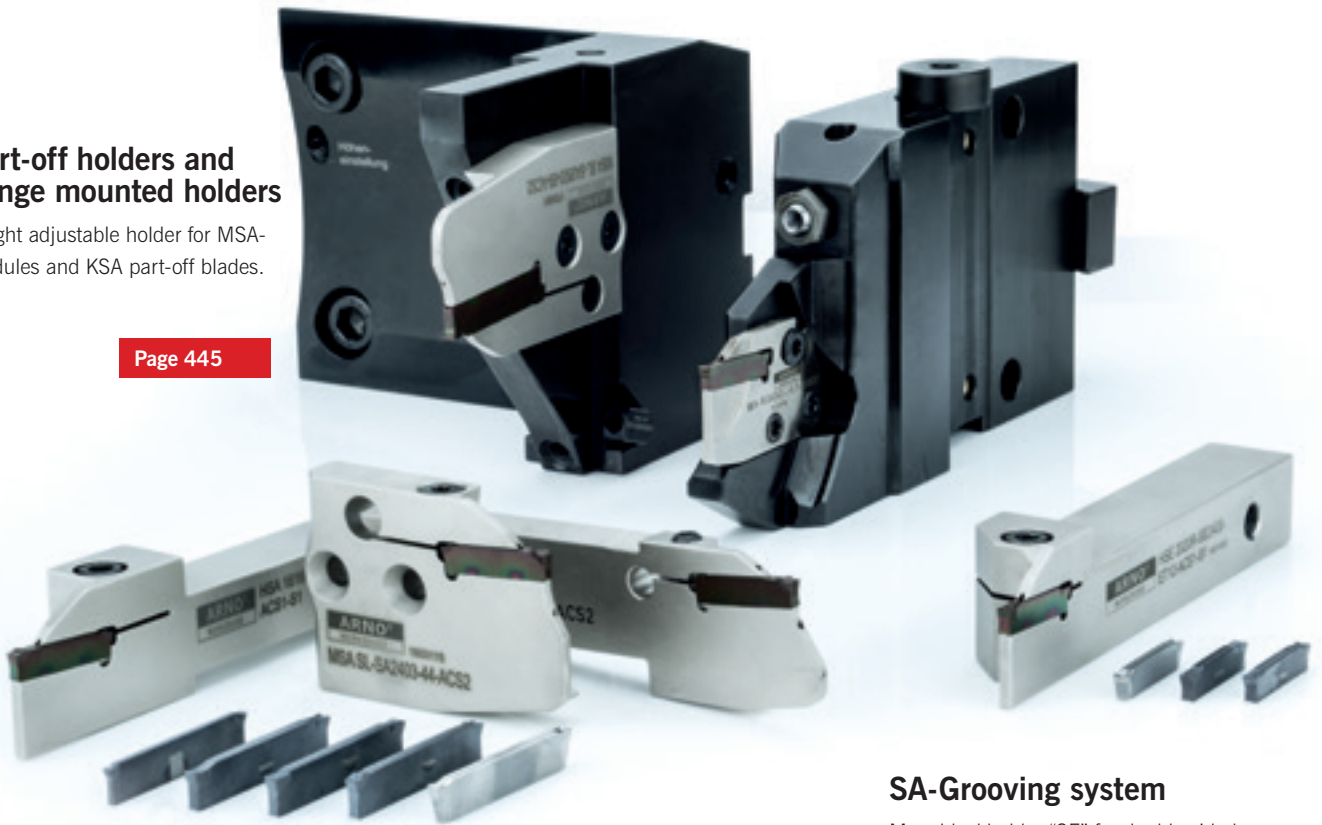

SA-Grooving system

Solutions for part-off and grooving up to 140 mm diameter, with a number of different tooling designs.

Page 45



Page 199

NC-Groove turning system

External and internal groove turning system for radial, axial and "Contra" grooving applications.



Page 279

SHORT-CUT

The rigid system for grooving and copy-turning with one tool.



Page 305

CLIP-GROOVE

Form grooving system for radial or axial application with 3-edged insert.

SA-Grooving system

Monoblockholder "SE" for double sided inserts for grooving, part-off and copy turning.

Page 153

Get into the Groove. ARNO-Grooving tools and inserts.

Take advantage of ARNO's unique versatility:

A modular grooving system with a single basic tool holder turns into different tool variants by simply changing the support blade and clamp.

Thanks to their stability, the grooving tools offers chip removal in all 3 main cutting directions, enabling combined operations with just one tool.

Precision-ground two- or three-edged cutting inserts in various designs, different shapes and types, give the best cutting performance in respect of chip forming, cutting speed and efficiency.



PROFIL-CUT

Grooving system for creating customer specific grooves in one plunge.



ARNO®-Mini-System

AMS is a modular boring system starting at Dmin 0.7 mm with a maximum reach of 50 mm.



SIM – Boring Bars

Mini boring system for minimum bore diameter from 6.7 mm.

ARNO[®]

WERKZEUGE

0



Tradizione e precisione.

“Da un’impresa familiare a impresa a livello mondiale.”

1941 Emil Arnold fonda l’azienda ad Esslingen am Neckar. La produzione iniziale è dedicata alla costruzione di strumenti di misura e controllo. L’azienda è riconosciuta per la qualità dei propri prodotti e per la soddisfazione presso i propri clienti.

Insieme al figlio Karl-Heinz Arnold alla continua ricerca di innovazioni e sviluppi. Ha l’obiettivo di vendere i suoi utensili in tutti i Paesi e in tutti i rami dell’industria. Nel 1962 suo figlio fonda la Karl-Heinz Arnold GmbH che successivamente col nome di ARNO®-Werkzeuge si dedicherà al commercio di gli utensili in metallo duro.

1987 Klaus-Michael Arnold inizia la sua esperienza in azienda e nel 1992 ne acquisisce la proprietà. Insieme a Josef Storf, nominato amministratore nel 2002, si pone nuovi obiettivi e definisce le basi per lo sviluppo di nuovi prodotti. Nel 2004 viene aperta la prima filiale in Inghilterra. Subito dopo seguono Italia, Stati Uniti e Russia. Nell’anno 2014 abbiamo aperto la nostra azienda in Sinwgapore per anche seguire il mercato sudest asiatico. La distribuzione dei prodotti viene oggi garantita in tutto il mondo grazie ad una capillare distribuzione e ad un efficiente servizio.

ARNO®

WERKZEUGE

0



Scanalatura

Con ARNO®-Werkzeuge troverete il giusto utensile per ogni tipo di scanalatura: radiale, assiale, interna.

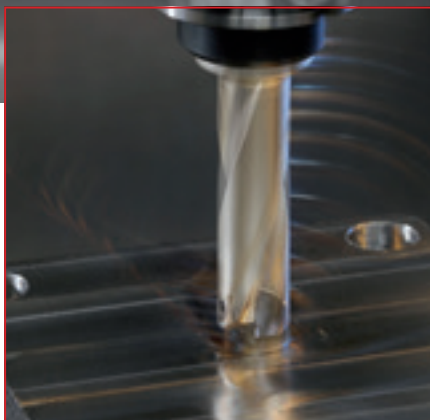

Foratura

Nella nostra gamma prodotti troverete punte in HSS, Metallo duro, ad inserti e a cuspidi per diametri da 1 mm a 114 mm.



Tornitura

ARNO®-Werkzeuge offre utensili affidabili con diversi inserti per le migliori prestazioni di lavorazione interna od esterna.

Forza grazie all'esperienza, competenza e sviluppo.

“Per il futuro avete bisogno di un partner con un futuro.”

Grazie all'intensiva collaborazione dentro e fuori dall'azienda siamo in grado di esaudire ogni richiesta del cliente. Per questo siamo alla ricerca continua di prodotti da sviluppare da aggiungere alla nostra ampia gamma prodotti.

Nuovi materiali e nuove condizioni di lavorazione ci spingono a sviluppare nuovi prodotti da lanciare sul mercato come utensili modulari che possono essere adattati alle singole esigenze. La nostra gamma di prodotti spazia dalla foratura, alla scanalatura e fresatura, tornitura ad inserti, oltre a sistemi di bloccaggio e distributori automatici di utensili.

Oltre ai prodotti di qualità offriamo anche competenza e consulenza. Il nostro team esaudirà le vostre richieste e vi guiderà nella scelta.



Fresatura

Fresatura piana, circolare, sgrassatura anche per queste applicazioni abbiamo l'utensile giusto.



Distributori di utensili

Lo StoreManager garantisce sicurezza e flessibilità.



Bloccaggio utensili

Morse NC semplici o doppie per un bloccaggio ottimale del pezzo.

ARNO[®]

WERKZEUGE

0

Servizio di qualità.

Soluzioni speciali individuali

Con la nostra vasta gamma di prodotti siamo attrezzati per ogni richiesta. Avete bisogno di un utensile particolare per una lavorazione particolare? Rivolgetevi a noi e vi forniremo un prodotto studiato su misura per voi. Risultati perfetti senza limiti!

Consegna in 24 ore

Avete fretta? Nessun problema, poiché se riceviamo i vostri ordini entro le 15:30 garantiamo la consegna il giorno successivo. Le situazioni di disponibilità dei prodotti standard sono visibili da tutti i nostri clienti tramite un innovativo accesso WEB.

Tutto sotto lo stesso tetto

L'elevata qualità dei nostri prodotti è garantita dal fatto che la progettazione, la produzione e la distribuzione avvengono in un unico posto. Ciò permette tempistiche veloci, miglior controllo prezzo favorevole.

Un grande team

Non vi lasciamo soli. Il nostro team vi visiterà regolarmente e vi supporterà nella scelta del prodotto più adatto a voi.

I nostri tecnici

Avete una domanda o problemi di lavorazione? I nostri tecnici vi visiteranno e risponderanno ad ogni vostro quesito.

Ordini Hot Line

Avete la possibilità di raggiungere un collaboratore ARNO in tutto il mondo. Approfittate del nostro help desk telefonico. Tecnici professionali sono a vostra completa disposizione.

Utilizzati nel mondo, assistenza sul posto.

Potete trovare gli utensili ARNO in tutto il mondo. Per noi è importante offrire un servizio localizzato e grazie alle filiali e i vari partner commerciali siamo in grado di raggiungervi in tutto il mondo.

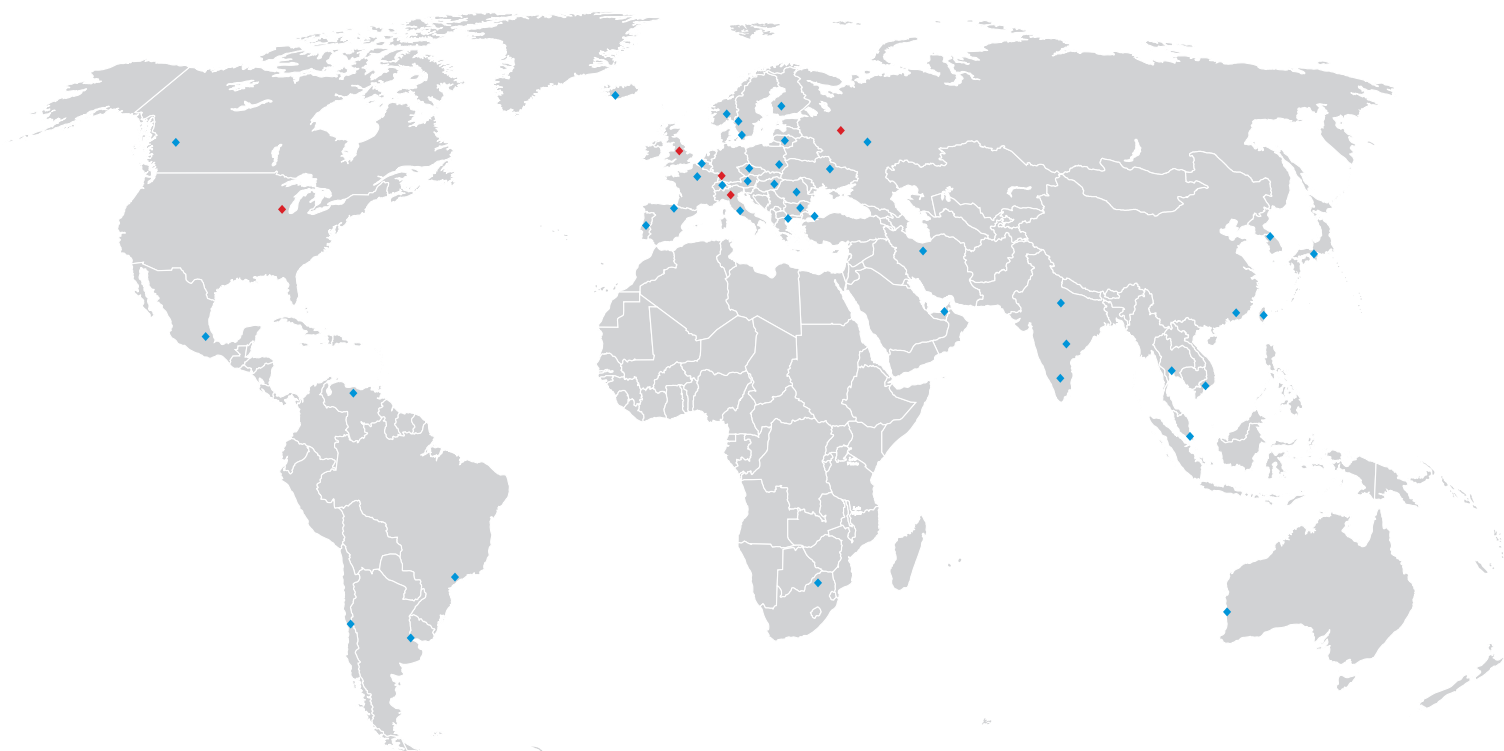

◆ Filiali

◆ Partner commerciali

Karl-Heinz Arnold GmbH
Karlsbader Str. 4
73760 Ostfildern

Tel.: +49 (0) 711/34 802-0
Fax: +49 (0) 711/34 802-130
bestellung@arno.de
anfrage@arno.de
www.arno.de

ARNO (UK) Limited | Unit 9, 10 & 11, Sugnall Business Centre | Sugnall, Eccleshall | Staffordshire | ST21 6NF
☎ +44 01785 850 072 | 📠 +44 01785 850 076 | sales@arno.de | www.arno-tools.co.uk

ARNO Italia S.r.l. | Via J. F. Kennedy 19 | 20871 Vimercate (MB)
☎ +39 039 68 52 101 | 📠 +39 039 60 83 724 | info@arno-italia.it | www.arno-italia.it

ARNO-Werkzeuge USA LLC | 1101 W. Diggins St. | US-60033 Harvard, Illinois
☎ +1 815 943 4426 | 📠 +1 815 943 7156 | info@arnousa.com | www.arnousa.com

ARNO RU Ltd. | Krassnaja Ul. 38 | RU-600015 Vladimir
☎ / 📠 +7 4922 541125 | 📞 +7 4922 541135 | info@arnoru.ru | www.arnoru.ru

Adattatori di troncatura e attacchi base

Registrabili in altezza per moduli MSA e lame KSA.

Pagina 445



SA-Sistema di troncatura

Soluzioni di troncatura fino a Ø 140 mm in diverse combinazioni stelo/modulo/lama.

Pagina 45



Pagina 199

Sistema di scanalatura e copiatura

Sistema di scanalatura universale per lavorazione interna ed esterna radiale, assiale e kontra.



Pagina 279

SHORT-CUT

Robusti per lavorazioni generiche e copiatura.



Pagina 305

CLIP-GROOVE

Sistema di scanalatura con inserti a tre taglienti per lavorazioni assiali o radiali.

SE-Sistema di troncatura

Steli monoblocco "SE" per inserti bitaglianti per scanalatura, troncatura e scanalatura di copiatura

Pagina 153

Massima affidabilità Sistemi di troncatura e scanalatura ARNO.

I vantaggi di un sistema versatile e unico. Con il sistema ARNO-NC assemblare la forma di utensile richiesta è semplice: un attacco base da cui partire e una infinità di opzioni e di ricambi per ottenere utensili per gole radiali, assiali, inclinate.

Moduli specifici di troncatura completano ulteriormente le possibilità di utilizzo. Grazie all'elevata stabilità di assemblaggio, la lavorazione e le operazioni composte sono quindi possibili in tutte e tre le direzioni principali di taglio. La precisione degli inserti rettificati e non, a due o tre taglienti in una varietà di geometrie e qualità giuste per ognuno dei vostri progetti.

Questo catalogo Vi illustrerà una panoramica dei nostri sistemi di scanalatura ARNO.



Pagina 337

PROFIL-CUT

Sistema per profilo ad inserti.



Pagina 351

ARNO®-Mini-Sistema

AMS è un sistema modulare per una lavorazione flessibile da diametri di 0,7 mm o con profondità del foro massima fino a 50 mm.



Pagina 409

SIM – Barenì

Sistema di utensili con vite frontale per lavorazioni in diametro del foro a partire da 6,7 mm.

0

Innenkühlung / Through tool coolant / Adduzione interna del refrigerante

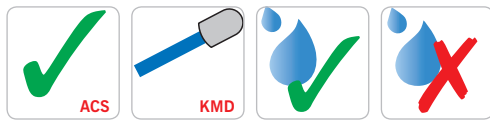

mit Kühlmitteldüse
with coolant jet
con ugello refrigerante

Ausführung Rechts / Links / Überkopf

Execution Right-hand / Left-hand / Upside down
Versione Destra / Sinistra / Rovesciati

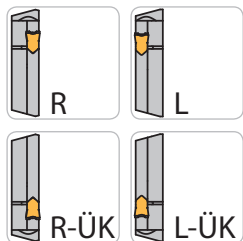
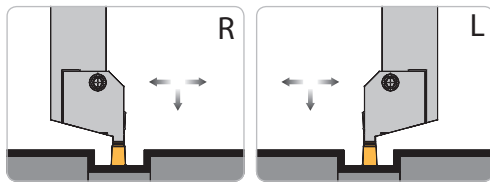

Schaftausführung / Holder design / Tipo di stelo

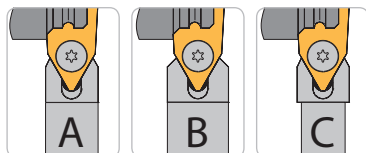

Sonstige / Other / Altro



SA-Steichsystem**SA-Grooving system****SA-Sistema di troncatura****Ein- und Abstechsystem***Grooving and parting system*

Sistema di troncatura e scanalatura

• Systemvorstellung	• <i>Introduction</i>	• Caratteristiche del sistema	46 – 55
• Monoblockhalter	• <i>Monoblock holders</i>	• Utensili monoblocco	56 – 93
– Werkzeugauswahl	– <i>Tool shank options</i>	– Tipologie di corpo utensile	56
– Bezeichnungssystem	– <i>Designation system</i>	– Sistema di identificazione	57
– Monoblockhalter	– <i>Monoblock holders</i>	– Utensili monoblocco	58 – 93
• Stechklingen	• <i>Blades</i>	• Lame da taglio	94 – 113
– Werkzeugauswahl	– <i>Tool shank options</i>	– Tipologie di corpo utensile	94
– Bezeichnungssystem	– <i>Designation system</i>	– Sistema di identificazione	95
– Stechklingen	– <i>Blades</i>	– Lame da taglio	96 – 111
– Spannblöcke	– <i>Clamping blocks</i>	– Blocchi portalama	112 – 113
• Module	• <i>Modules</i>	• Moduli	114 – 128
– Werkzeugauswahl	– <i>Tool shank options</i>	– Tipologie di corpo utensile	114
– Bezeichnungssystem	– <i>Designation system</i>	– Sistema di identificazione	115
– Halter für SA-Module (MSA)	– <i>Tool holders for SA-Modules (MSA)</i>	– Steli per moduli SA (MSA)	116 – 117
– Module	– <i>Modules</i>	– Moduli	122 – 128
• Schneideinsätze	• <i>Inserts</i>	• Inserti	129 – 141
– Geometrie	– <i>Geometry</i>	– Geometria	129
– Sortenbeschreibung	– <i>Grade description</i>	– Descrizione delle Qualità	130 – 131
– Schneideinsätze	– <i>Inserts</i>	– Inserti	132 – 141
• Ersatzteile und Zubehör	• <i>Spare parts and accessories</i>	• Ricambi e accessori	142
• Schnittwerte	• <i>Cutting data</i>	• Parametri di taglio	144 – 149
• Anwendungshinweise	• <i>Application reference</i>	• Suggestimenti tecnici	150 – 151



1

Lösungen für das Einstechen und Abstechen bis Ø 140 mm vereint in verschiedenen Werkzeugausführungen

Solutions for part-off and grooving up-to 140 mm diameter, with a number of different tooling designs

Soluzioni di troncatura e scanalatura fino a Ø 140 mm in diverse combinazioni di utensili

Monoblockhalter

8 × 8 bis 32 x 32 mm

Monoblock holders

8 × 8 to 32 x 32 mm

Utensili monoblocco

da 8 × 8 a 32 x 32 mm



Stechklingen

in den Größen 26 und 32

Blades

in sizes 26 and 32

Lame da taglio

nei formati 26 e 32



Module

Modules

Moduli



Systemvorstellung

Monoblockhalter

- Schäfte von 8 x 8 bis 32 x 32 mm
- Stechbreiten 1,5 bis 10 mm

Stechklingen

- In Größen 26 und 32
- Stechbreiten 1,5 bis 4 mm

Module

- Einstechtiefe ET_{max} 10,0 – 70,0 mm
- Stechbreiten 1,5 bis 4 mm
- ACS-Modul mit Innenkühlung

Fakten

- **Monoblockausführung**
– Anwendungssicher, einfaches Handling – nur ein Ersatzteil
- **Aktive Schneidplattenklemmung mit Fixanschlag**
– Genaue Schneidenpositionierung
– Kein Herausziehen des Schneideinsatzes möglich
- **Zweischneidige Schneideinsätze**
– Hohe Wirtschaftlichkeit
- **Direkt gepresste Schneideinsätze mit speziellen Geometrien**
– Kostengünstige und optimale Lösung für sichere Stechprozesse

1

Introduction

Monoblock holders

- Shank sizes from 8 x 8 to 32 x 32 mm
- Groove widths from 1.5 to 10 mm

Blades

- Sizes 26 and 32 mm
- Groove widths from 1.5 to 4 mm

Modules

- Grooving depth ET_{max} 10.0 – 70.0 mm
- Groove widths from 1.5 to 4 mm
- ACS-Module with through tool coolant

Features

- **Monoblock design**
– Reliable and user friendly – only one spare part
- **Active insert clamping with fixed stop**
– Accurate insert positioning. Pulling out the insert is not possible
- **Double edged inserts**
– High productivity
- **Directly pressed inserts with dedicated geometries**
– Cost efficient and optimum solution for reliable groove production

Descrizione

Utensili monoblocco

- Steli da 8 x 8 fino a 32 x 32 mm
- Larghezza di taglio da 1,5 a 10 mm

Lame da taglio

- In dimensioni 26 e 32 mm
- Larghezze di taglio da 1,5 a 4 mm

Moduli

- Profondità di taglio ET_{max} 10,0 – 70,0 mm
- Larghezze di taglio da 1,5 a 4 mm
- ACS-Modulo con adduzione interna

Caratteristiche

- **Monoblocco**
– Sicuro e di semplice utilizzo – senza ricambi
- **Bloccaggio assiale con fermo**
– Posizionamento preciso e sicuro dell' inserto impossibile lo spostamento in sede
- **Bi-tagliente**
– Economico
- **Inserti con geometrie specifiche**
– Forme specifiche per materiali e per una lavorazione affidabile

ARNO-ACS cooling system®

Patentierter Kühlung durch Unterspülung

Coolant under the swarf

Refrigerante sotto il truciolo

ACS1

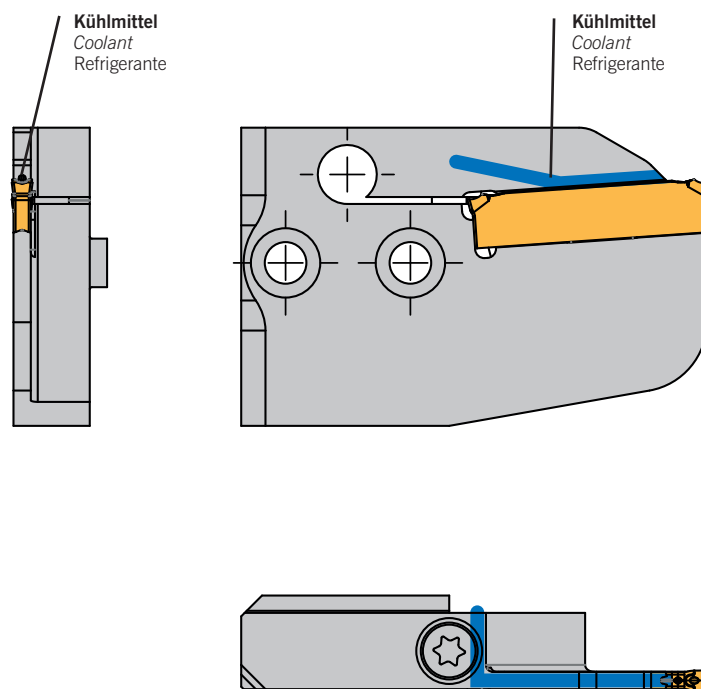

Neue Technologie für Stechmodule, Klingen und Monoblockhalter. Spezielles Kühlungssystem sichert die Unterspülung des Spanes und verbessert Standzeiten deutlich.

Bisher gibt es am Markt externe sowie interne Kühlungsvarianten, die jedoch oft einen erheblichen Streuungsverlust bis zur Schneidkante aufweisen. Besonders bei tieferen Ein- und Abstichen reduziert sich dadurch der Kühlungseffekt enorm und der Abtransport der Späne wird erschwert.

ARNO®-Werkzeuge hat diese Probleme erkannt und mittels neu entwickelter Technik, dem ARNO-ACS cooling system® (ACS), erfolgreich beseitigt. Dieses innovative System ermöglicht die optimale Kühlung der Stechplatte während der Bearbeitung. Es stehen zwei Kühlvarianten zur Verfügung: ACS1 mit einem Kühlmittelkanal sowie ACS2 mit zwei Kühlmittelkanälen.

New technology for modules, blades and monoblock holders. The special coolant system ensures the flow is directed under the swarf and thereby improves tool life considerably.

The market place has already seen many coolant variations which often loses much of efficiency due to poor accuracy from the spray jet to the cutting edge and especially in applications with a deeper groove depth the desired coolant effect and swarf evacuation suffers from only little or no improvement.

ARNO®-Werkzeuge has realised this problem area and by developing the ARNO®-Cooling-System (ACS) solved the problem. This innovative design ensures optimum coolant to the cutting edge during machining. It comes in two variations: ACS1, with one coolant hole and ACS2 with two coolant holes.

Nuova tecnologia per moduli, lame e steli integrali. Lo speciale passaggio del refrigerante assicura di raggiungere il punto più vicino possibile alla zona di taglio riducendo le temperature e incrementando la vita inserto considerevolmente.

Il mercato offre oggi innumerevoli sistemi di adduzione che però perdono la loro efficienza con la distanza dal punto di taglio o per la bassa precisione del getto. Nei casi di gole molto profonde questo ha un significato importantissimo anche per una migliore evacuazione truciolo.

ARNO®-Werkzeuge ha identificato queste problematiche e su queste focalizzato la ricerca e sviluppo che con il nuovo sistema di refrigerazione ARNO® ACS ha eliminato con successo. Questo sistema innovativo consente un raffreddamento ottimale del tagliente, degli utensili e del materiale durante la lavorazione. Due sono le opzioni di raffreddamento disponibili: ACS1 con un solo canale di refrigerazione e ACS2 con due canali di refrigerazione.

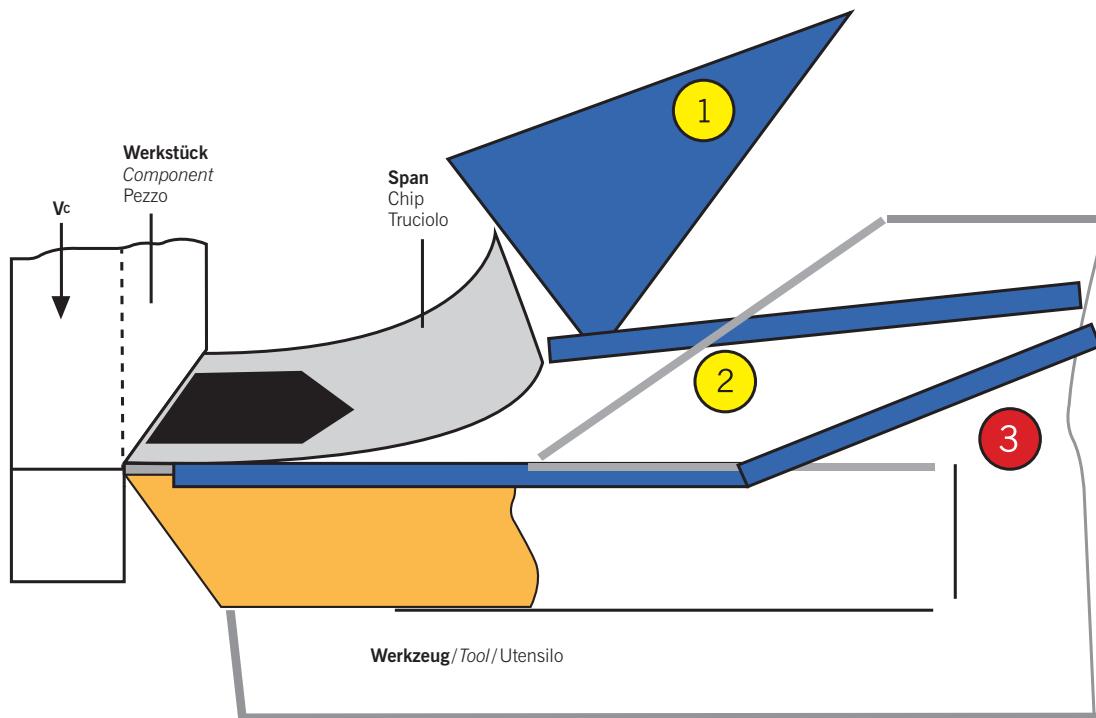

- 1 „Externe Kühlung“ über Spritzdüse/External coolant from coolant jet/Refrigerazione “estesa” dei sistemi tradizionali (su truciolo)
- 2 „Interne Kühlung“ über Halter oder Spannpratze/Through tool coolant/Refrigerazione direzionata tramite adduzioni interne classiche (su truciolo)
- 3 Neue „ACS-Kühlung“ direkt durch den Plattensitz/New ACS-coolant through the insert seat/Nuovo ACS ARNO-Cooling-System direttamente sul filo tagliente



ARNO-ACS cooling system®

ACS2 – doppelt ist noch besser

ACS2 – 2 is better than 1

ACS2 – 2 è meglio di 1

ACS2

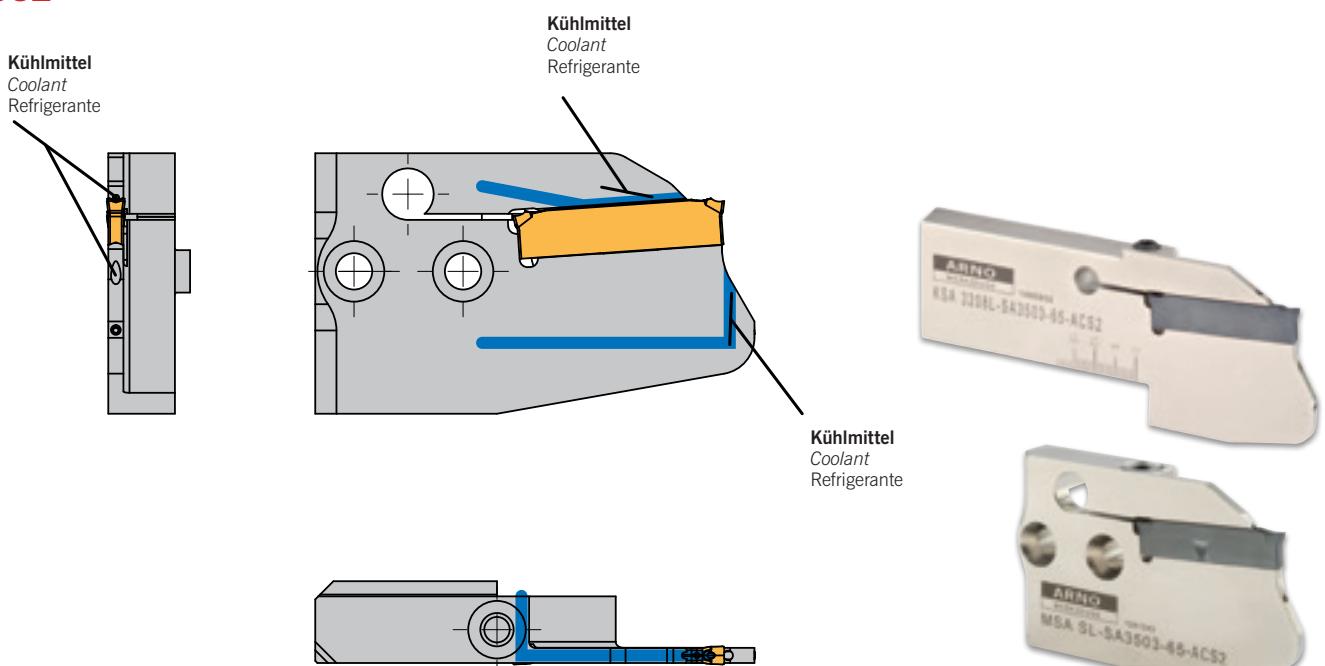

Zusätzliche Kühlung durch einen zweiten Kühlmittelstrahl direkt auf die Freifläche.

Der Kühlmittelstrahl wird direkt durch den Plattensitz geleitet und trifft somit zielgerichtet auf die Schnittzone. Ein Wirkungsverlust wie bei anderen Methoden ist dabei ausgeschlossen, stattdessen wird auch bei tiefen Einstichen optimal an der Schnittstelle gekühlt.

Die konstruktive Auslegung des Strahls verursacht dabei eine Unterspülung des Spanes und sichert so optimale Zerspanungsbedingungen direkt an der Wirkstelle. Zusätzlich werden die Bildung einer Aufbauschneide und die Gefahr von Ausbrüchen an der Schneidkante weitgehend verhindert.

Beim ACS2 wird zusätzlich die Freifläche der Stechplatte von unten gekühlt. Gegenüber herkömmlichen Kühlungen sind dadurch höhere Schnittparameter und bessere Standzeiten möglich.

With an additional coolant hole you get the coolant right to the tool flank.

The coolant hole is going through the insert seat and aims directly at the cutting edge, even in the deepest groove the cutting edge is kept cool and any loss of effectivity, as seen in other systems, is prevented.

The coolant gets underneath the swarf and guarantees optimum cutting conditions. Additional benefits are the reduction of build-up edges and breakouts of the cutting edge.

With the additional coolant hole of the ACS2 system we offer higher cutting parameters and better tool life.

Attraverso un secondo canale di refrigerazione, il getto raggiunge direttamente il filo di taglio dalla spoglia inferiore.

Il getto raggiunge il punto più vicino possibile alla zona di taglio passando internamente all'utensile. La perdita di efficacia che si verifica nei sistemi concorrenti non si verifica invece nel sistema ARNO® ACS. Anche la più profonda delle scanalature o delle troncature verrà refrigerata a dovere riducendo le temperature e incrementando la vita inserto considerevolmente.

Ulteriori benefici si possono ottenere grazie alla riduzione del tagliente di riporto e relative scheggiature dei taglianti. Il sistema ACS2 ha un ulteriore canale di adduzione del refrigerante che raggiunge il tagliente dalla parte sottostante garantendo il raggiungimento del punto di contatto col materiale riducendo al massimo le temperature.

ARNO®

WERKZEUGE

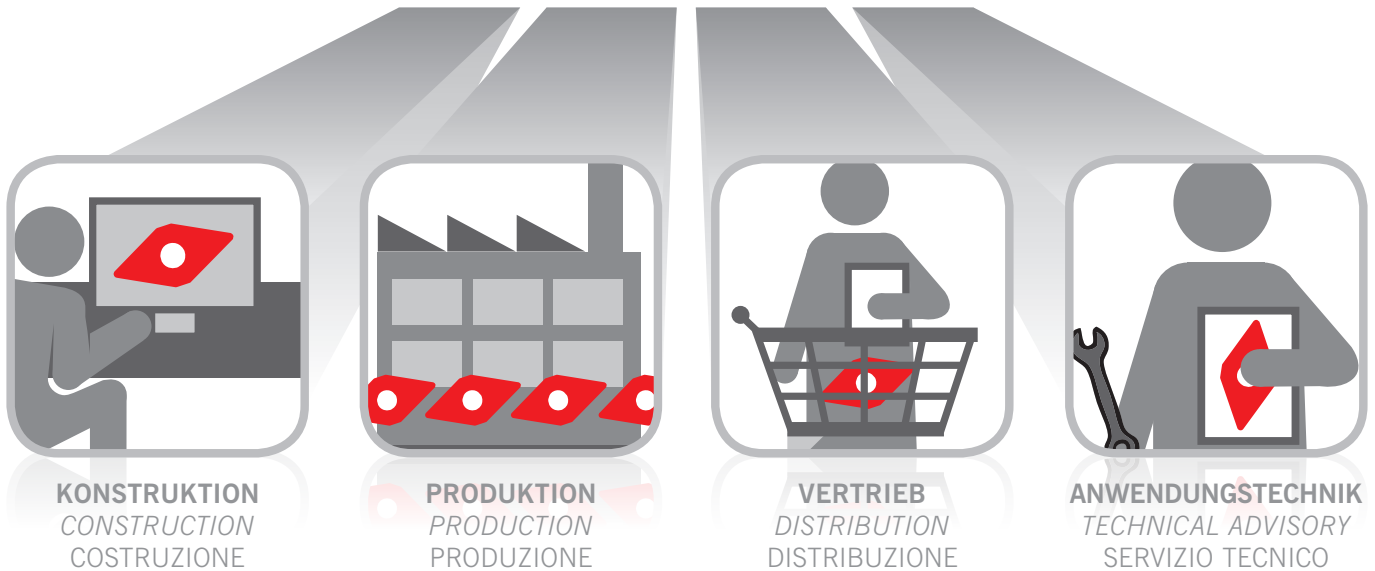

Schnell, flexibel und individuell.

Quick, flexible and individual.

Veloce, flessibile e individuale.

Konstruktion, Produktion und Vertrieb unter einem Dach.

Das ist die perfekte Verbindung um Ihnen Standard- und Sonderprodukte schnell und hochwertig anbieten zu können.

95% der Standardprodukte sind sofort verfügbar: Bei Bestellung bis 18 Uhr erhalten Sie Ihre Produkte bereits am nächsten Tag.

Mit großer fachlicher Kompetenz betreut Sie unser Außendienst-Team, unsere Anwendungstechniker helfen Ihnen mit Spezial-Wissen gerne auch vor Ort.

To have design, production and service all under one roof

is the perfect way of providing standard and special products.

95% of the standard programme is available from stock. Order received before 18.00 CET are dispatched the very same day and in most cases supplied next day.

Our competent team of technical sales engineers will be available to support you on site.

Costruzione, Produzione e Distribuzione sotto un unico tetto.

La sequenza perfetta per garantire un servizio di supporto cliente su prodotti Standard e Speciali di alta qualità.

Il 95% dei prodotti Standard sono disponibili a stock; con ordini entro le 18:00 garantiamo la consegna il giorno successivo.

Il nostro team di vendita altamente qualificato si offre come supporto alla produzione presso i nostri clienti direttamente sul territorio.

Weitere Informationen finden Sie unter:

For more information see:

Altre informazioni su:

www.arno.de

ARNO-ACS cooling system®

Gegen zu hohe Temperaturen an der Schneide

Solving the problem of high temperatures at the cutting edge

Risolve problemi legati allo sviluppo di elevate temperature sul tagliente

Ohne ACS – externe Kühlung

Without ACS – external coolant

Senza ACS – refrigerazione esterna

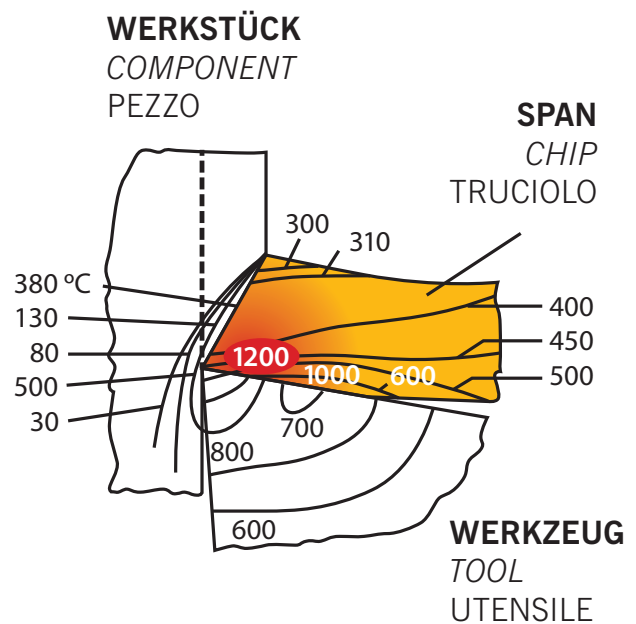
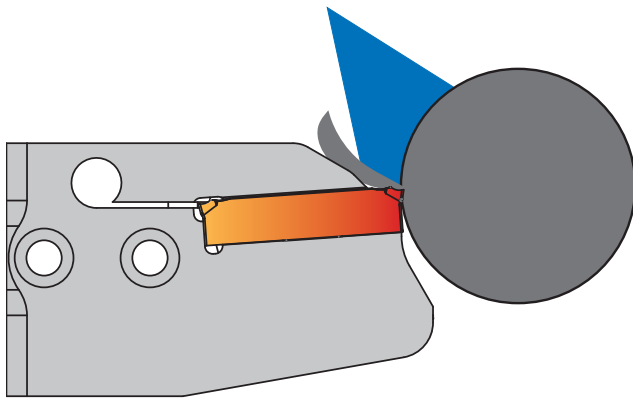

Mit dem ARNO-ACS cooling system® des SA- (Einstechen und Abstechen) Programmes haben Sie ein Werkzeugsystem an der Hand, das gegenüber den Wettbewerbern herausragende Leistungen bietet. Als einziger Anbieter auf dem Zerspanungsmarkt, bekommen Sie bei ARNO® ein System, das den Kühlmittelstrahl direkt durch den Plattensitz leitet und so ohne Hindernisse direkt in die Schnittzone gelangt.

Vorteile:

- Höchste V_c und Vorschübe möglich
- Reduzierung der Aufbauschneidenbildung, Verringerung der Kammissbildung durch die Vermeidung von Thermoschocks
- Kontrollierter Spanbruch
- Beste Oberflächenqualität
- Hervorragende Parallelität
- Alle Halter sind mit ihrer vernickelten Oberfläche bestens vor Korrosion geschützt
- Kein Aus- bzw. Einrichten der Kühlmitteldüsen notwendig – Reduzierung der Rüstzeit

Die zweiseitigen Schneidplatten sind für Werkzeuge mit ACS Innenkühlung in den Stechbreiten von 2 bis 6 mm und für Stechtiefen bis 105 mm erhältlich. Sieben Hartmetall-Sorten und sechs Spanleitstufen (teilweise bis 15° Schräge geschliffen) bieten Ihnen eine umfangreiche Auswahl für nahezu alle gängigen Werkstoffe.

Mit den passenden Abstechhaltern und Direktaufnahmen steht Ihnen ein durchgängig abgestimmtes Konzept von der Maschinenschnittstelle bis in die Schnittzone zur Verfügung.

With the ARNO-ACS cooling system® on the SA- (part-off and grooving) system we have a highly competitive solution against any competitor system. Unique to our ACS system, we offer through tool coolant directly and totally unhindered to the cutting edge.

Advantages:

- Maximum speed and feed possible
- Reduction of build up edge and thermal cracking by avoiding thermal shocks
- Well controlled chip breaking
- Superb surface finish
- Excellent flatness
- All holders are nickel plated and therefore protected against corrosion
- Reduced set-up time as there is no requirement for adjusting coolant jet

Mit ACS – Kühlung durch Unterspülung

With ACS – coolant under the swarf

Con ACS – refrigerante sotto il truciolo

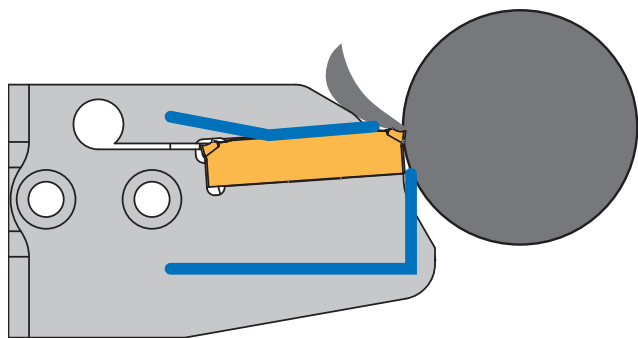

The ACS cooling system is available for double sided inserts from groove width 2 to 6mm and groove depth up to 105mm. By offering 6 carbide grades and 5 chip breakers (including inserts ground with a 15° angle) we offer a solution for nearly all materials.

With the correct tool and flange mounted holder you will get the maximum performance out of your machines capability.

Il Sistema ARNO-ACS Cooling System® applicato sulla linea prodotti SA (troncatura e scanalatura) garantisce soluzioni di utensili dalle massime prestazioni rispetto alla concorrenza. Una soluzione tecnica unica del suo genere che raggiunge con la massima precisione il tagliente senza ostacoli, garantendo la massima efficacia di raffreddamento nella zona di taglio.

Vantaggi:

- Massimi avanzamenti e velocità di taglio
- Riduzione della formazione del tagliente di riporto
- Riduzione dell shock termico
- Migliorato controllo truciolo
- Migliorata formazione e rottura del truciolo
- Ottima finitura superficiale
- Eccellente planarità delle superfici
- Utensili nickelati resistenti alla corrosione
- Ridotti tempi di setup non avendo ugelli direzionabili

WERKSTÜCK

COMPONENT

PEZZO

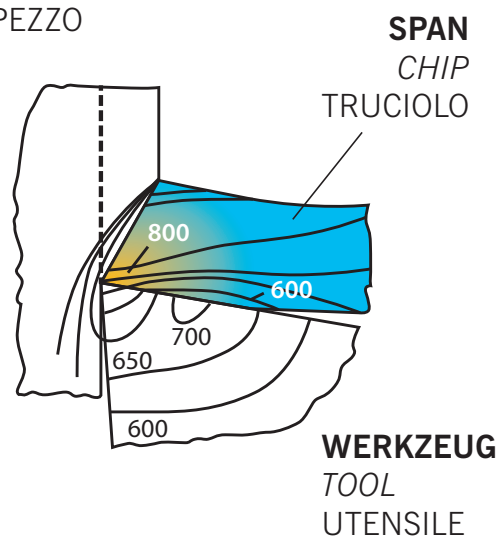

Il sistema ARNO-ACS Cooling System è disponibile con inserto bi-tagliente per larghezze di taglio da 2 a 6mm e per una profondità massima di 105mm. Con 6 differenti gradi di metallo duro e 5 diverse geometrie di rompitrucciolo (più varianti con angoli frontali fino a 15°) offriamo una soluzione alla lavorazione di tutti i materiali.

Con la giusta composizione di utensile ed attacco diretto sulla torretta si ottiene il sistema più rigido, compatto e performante per la desiderata operazione di taglio.

ARNO-ACS cooling system®

Aus der Praxis für die Praxis

Practical examples

Dalla pratica, per la pratica

1

Praxistest 1 / Cutting trial 1 / Esempio 1

Düse / Jet / Raccordo	
<p>Abstechen mit ARNO®-Modul ACS2 Bearbeitungslänge 15 mm Stechbreite 3 mm</p> <p>$V_c = 120 \text{ m/min}$ $f_n = 0,12 \text{ mm/U}$</p> <p>Modul: MSA-SL-SA3503-65-ACS2 Schneidplatte: SA35-3003N-S1 AM5040</p> <p><i>Part-off with ARNO®-ACS2 module</i> <i>Application length 15 mm</i> <i>Part-off width 3 mm</i></p> <p>$V_c = 120 \text{ m/min}$ $f_n = 0.12 \text{ mm/U}$</p> <p><i>Module: MSA-SL-SA3503-65-ACS2</i> <i>Insert: SA35-3003N-S1 AM5040</i></p> <p>Troncatura con modulo ARNO® ACS2 Profondità di gola 15 mm Larghezza taglio 3 mm</p> <p>$V_c = 120 \text{ m/min}$ $f_n = 0,12 \text{ mm/U}$</p> <p>Modulo: MSA-SL-SA3503-65-ACS2 Inserto: SA35-3003N-S1 AM5040</p>	
<p align="center">ARNO® – ohne / without / senza ACS</p>	<p align="right">120 Teile / parts / pezzi</p>
<p align="center">ARNO®-ACS</p>	<p align="right">300 Teile / parts / pezzi</p>
<p>Kommentar:</p> <ul style="list-style-type: none"> • Material: X6CrNiMoTi17-12-2 (rost-, säure- und hitzebeständige Stähle) • Erhöhung der Standmenge um über 100 % • Ruhige und prozesssichere Bearbeitung <p><i>Information:</i></p> <ul style="list-style-type: none"> • <i>Material: stainless steel</i> • <i>Increase in productivity of over 100 %</i> • <i>Controlled and secure machining</i> <p>Informazioni:</p> <ul style="list-style-type: none"> • Materiale: Acciaio INOX • Incremento della produttività superiore al 100 % • Produzione affidabile e sicura 	

Introduction

Caratteristiche del sistema

Das patentierte ARNO-ACS cooling system® (ACS) verlängert durch die neue, innovative Kühlungstechnologie die Standzeiten um ein Vielfaches. Die Schneide wird optimal an der Schnittzone gekühlt, der Span wird unterspült und – auch bei tiefen Einstichen – optimal ausgeleitet. In mehreren Testversuchen, direkt beim Kunden, konnten wir mit den neuen ACS-Werkzeugen die Produktivität erheblich steigern.

The patented ARNO-ACS cooling system® (ACS) increases tool life significantly due to the new and innovative cooling technology. The cutting edge is kept cool while the chip is guided out of the groove, even in deep grooves. Multiple test at customers proved that the new ACS tools are increasing productivity significantly.

Il sistema brevettato ARNO®-Cooling-System (ACS) incrementa la vita inserto considerevolmente grazie alla innovativa tecnologia di adduzione del refrigerante. Il tagliente viene refrigerato fino al filo di taglio ed il truciolo lubrificato ed evacuato anche dalle più profonde troncature. Innumerevoli test sul campo hanno permesso, grazie al sistema ARNO® ACS, di ridurre notevolmente i costi di produzione.

1

Praxistest 2 Cutting trial 2 / Esempio 2

Buchse / Bush / Bussola	
<p>Abstechen mit ARNO®-Modul ACS2 Bearbeitungslänge ca. 8 mm Stechbreite 4 mm</p> <p>$V_c = 250 \text{ m/min}$ $f_n = 0,09 \text{ mm/U}$</p> <p>Modul: MSA-SL-SA3504-80-ACS2 Schneidplatte: SA35-4004N-ALU AN1015</p> <p><i>Part-off with ARNO®-ACS2 module</i> <i>Application length 8 mm</i> <i>Part-off width 4 mm</i></p> <p>$V_c = 250 \text{ m/min}$ $f_n = 0.09 \text{ mm/U}$</p> <p><i>Module: MSA-SL-SA3504-80-ACS2</i> <i>Insert: SA35-4004N-ALU AN1015</i></p> <p>Troncatura con modulo ARNO® ACS2 Profondità di gola 8 mm Larghezza taglio 4 mm</p> <p>$V_c = 250 \text{ m/min}$ $f_n = 0,09 \text{ mm/U}$</p> <p>Modulo: MSA-SL-SA3504-80-ACS2 Inserto: SA35-4004N-ALU AN1015</p>	
ARNO® – ohne / without / senza ACS	500 Teile / parts / pezzi
ARNO®-ACS	1.500 Teile / parts / pezzi
<p>Kommentar:</p> <ul style="list-style-type: none"> • Material: AlCuMgPb/AlCu4PbMgMn (Aluminium- und Magnesiumlegierungen) • Erhöhung der Standmenge um 300 % • Es wird auf eine Bohrung (Ø 24,5 mm) abgestochen <p><i>Information:</i></p> <ul style="list-style-type: none"> • <i>Material: Aluminium-Magnesium alloy</i> • <i>Productivity increase of around 300 %</i> • <i>Component has a 24.5 mm bore</i> <p>Informazioni:</p> <ul style="list-style-type: none"> • Materiale: Lega Alluminio Magnesio • Incremento della produttività attorno al 300 % • Il particolare ha un foro di 24,5 mm 	

1



Monoblockhalter / Monoblock holders / Utensili monoblocco

Seite/Page/Pagina **58 – 78**

 **ARNO®** SpecialDesign

Seite/Page/Pagina **68 / 75 / 80**



HSA-Werkzeughalter (VDI) / HSA-Holders (VDI) / Adattatore KMH (VDI)

Seite/Page/Pagina **84 – 93**



Schneideinsätze / Inserts / Inserti

Seite/Page/Pagina **132 – 141**

Monoblockhalter / Monoblock holders / Utensili monoblocco



Ausführung -S abgebildet
Design -S shown
Versione -S in figura

1

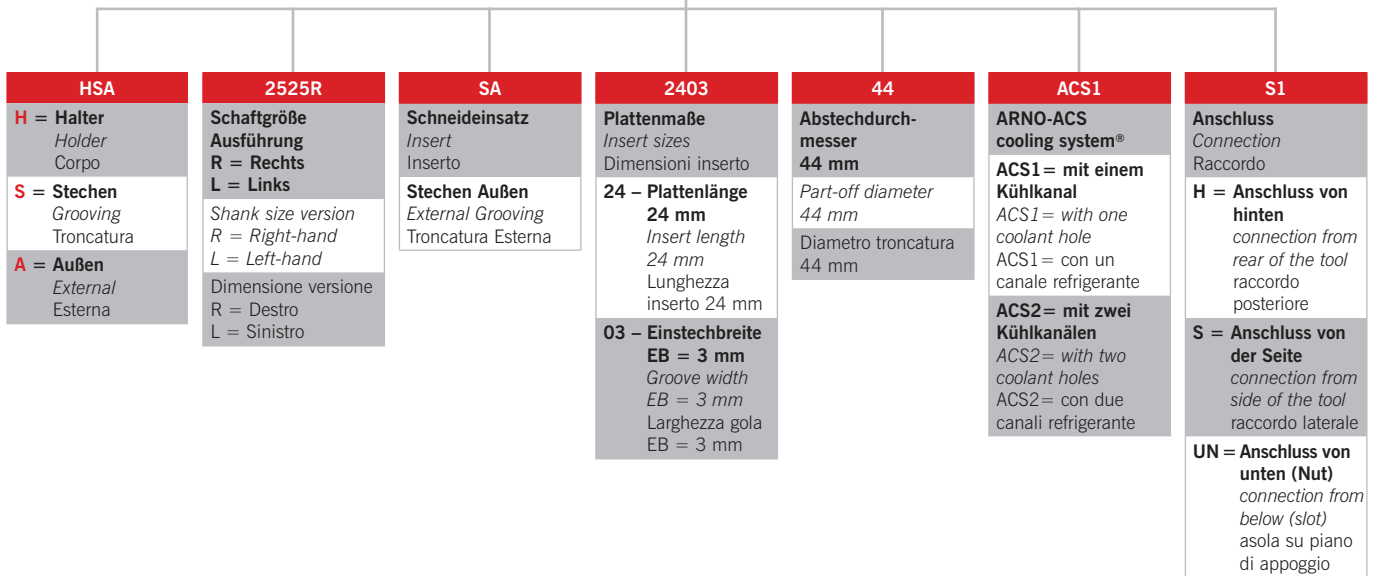

Schneideinsätze / Inserts / Inserti

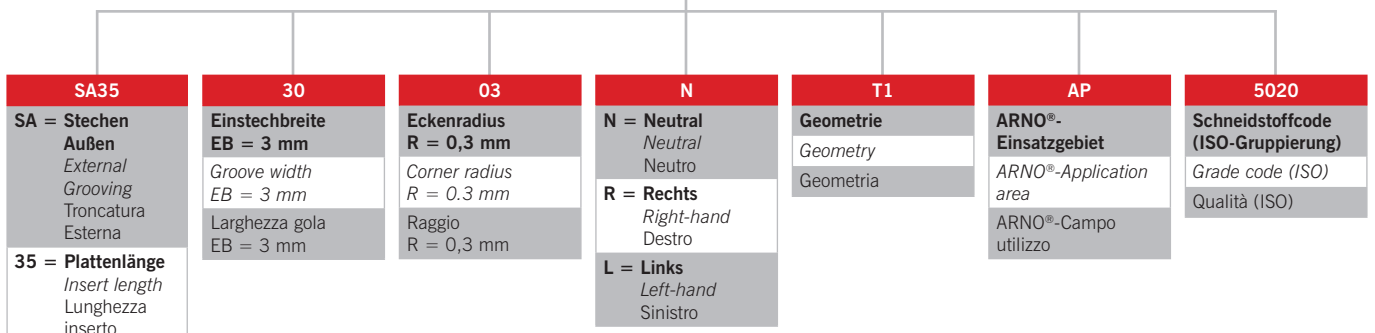

HSA-U

Für Langdrehautomaten (mit Klemmung von unten)

For sliding head auto lathes (with clamping from below)

Per fantina mobile (con bloccaggio da sotto)

1

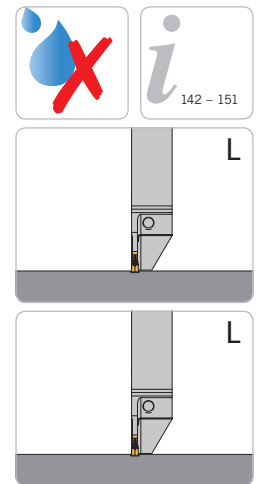
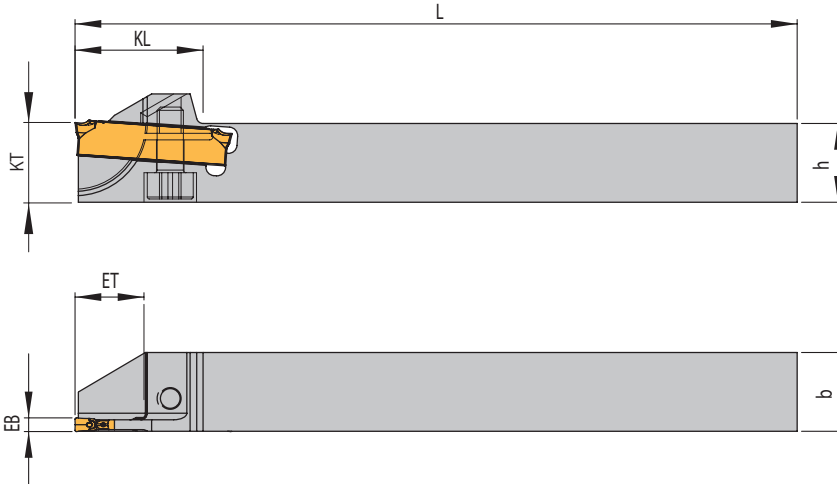

Rechte Ausführung abgebildet
Right-hand execution shown
Versione destra in figura

Trägerwerkzeuge / Holders / Utensili

Bezeichnung Designation Articolo	EB	ET	D _{max}	h	b	L	KL	KT	PG 37	Schneideinsatz Insert Inserto
HSA 1212U-L/R-SA16015-20	1,5	10	20	12	12	110	19,5	12	●	SA16-15...
HSA 1212U-L/R-SA24015-20	1,5	10	20	12	12	110	19,5	12	●	SA 24-15...
HSA 1212U-R-SA2402-06	2,0	3	6	12	12	110	19,5	12	●	SA 24-20...
HSA 1212U-L/R-SA2402-12	2,0	6	12	12	12	110	19,5	12	●	SA 24-20...
HSA 1212U-L/R-SA2402-20	2,0	10	20	12	12	110	19,5	12	●	SA 24-20...
HSA 1616U-L/R-SA2402-32	2,0	16	32	16	16	110	25,5	16	●	SA 24-20...

D_{max} = Maximaler Durchmesser bei Vollmaterial
D_{max} = Maximum diameter in solid
D_{max} = Diametro massimo lavorazione dal pieno

Ersatzteile / Spare Parts / Ricambi

Trägerwerkzeug Holder Utensile	Schraube Screw Vite	Schlüssel Key Chiave
HSA 1212U..	DIN912-M4X10-12.9	KP 1111
HSA 1616U..	DIN912-M4X14-12.9	KP 1111

HSA-UD

Monoblockhalter - Spannung von oben und unten

Monoblock holder - Locking from top and bottom

Utensile monoblocco - Bloccaggio da sopra e sotto

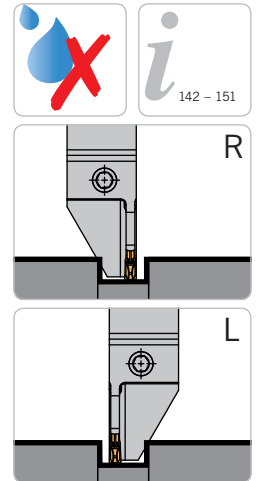
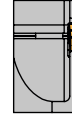
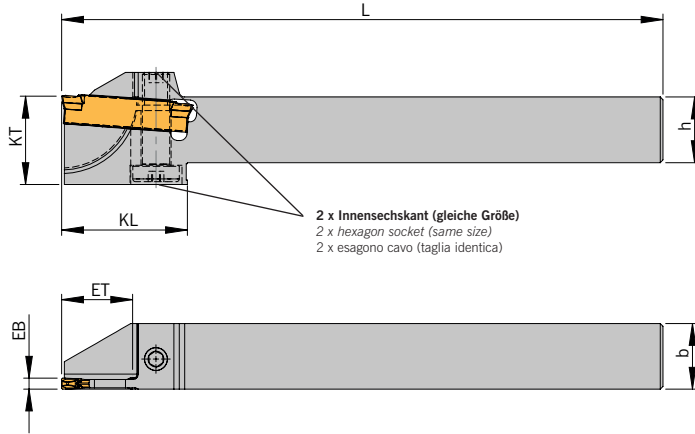

1

N NEU/NEW/NUOVO

Rechte Ausführung abgebildet
Right-hand execution shown
Versione destra in figura

Trägerwerkzeuge / Holders / Utensili

Bezeichnung Designation Articolo	EB	ET	D _{max}	h	b	L	KL	KT	PG 37	Schneideinsatz Insert Inserto
HSA 1212UD-L/R-SA2402-26 N	2	13	26	12	12	110	23	16	●	SA 24-20...

D_{max} = Maximaler Durchmesser bei Vollmaterial

D_{max} = Maximum diameter in solid

D_{max} = Diametro massimo lavorazione dal pieno

Ersatzteile / Spare Parts / Ricambi

Trägerwerkzeug Holder Utensile	Schraube Screw Vite	Schlüssel Key Chiave
HSA 1212UD..	AS 0084	KP 3111

HSA

Für Langdrehautomaten / For sliding head auto lathes / Per fantina mobile

1

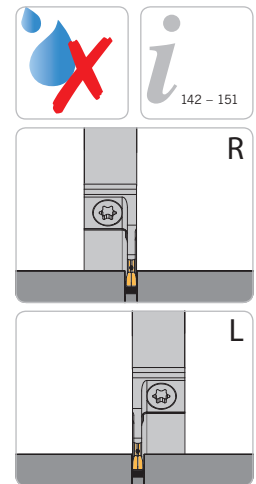
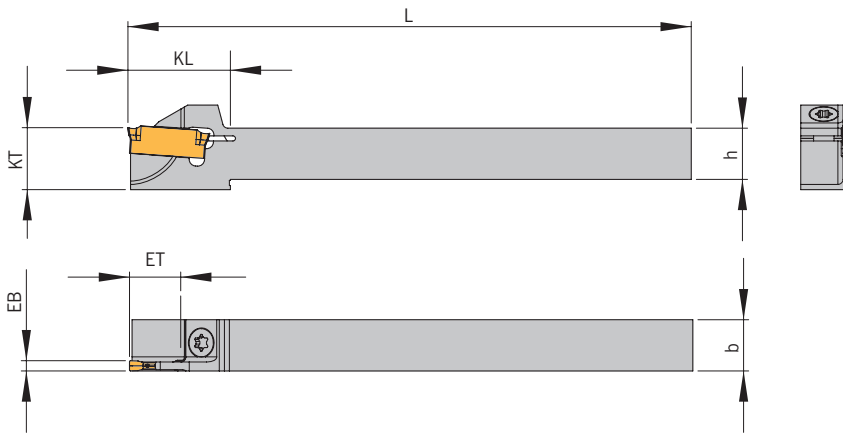

Rechte Ausführung abgebildet
Right-hand execution shown
Versione destra in figura

N NEU/NEW/
NUOVO

Trägerwerkzeuge / Holders / Utensili

Bezeichnung Designation Articolo	EB	ET	D _{max}	h	b	L	KL	KT	PG 37	Schneideinsatz Insert Inserto
HSA 0808L/R-SA16015-12	1,5	6	12	8	8	110	16,0	10	●	SA16-15...
HSA 0808L/R-SA16015-16	1,5	8	16	8	8	110	18,0	10	●	SA16-15...
HSA 0808L/R-SA24015-12	1,5	6	12	8	8	110	16,0	10	●	SA24-15...
HSA 0808L/R-SA24015-16	1,5	8	16	8	8	110	18,0	10	●	SA24-15...
HSA 1010L/R-SA16015-20	1,5	10	20	10	10	110	20,0	12	●	SA16-15...
HSA 1010L/R-SA1602-20	2,0	10	20	10	10	110	20,0	12	●	SA16-20...
HSA 1010L/R-SA24015-20	1,5	10	20	10	10	110	20,0	12	●	SA24-15...
HSA 1010L/R-SA2402-20	2,0	10	20	10	10	110	20,0	12	●	SA24-20...
HSA 1212L/R-SA16015-20	1,5	10	20	12	12	110	19,5	-	●	SA16-15...
HSA 1212L/R-SA1602-20	2,0	10	20	12	12	110	-	-	●	SA16-20...
HSA 1212L/R-SA1603-26	3,0	13	26	12	12	110	-	-	●	SA16-30...
HSA 1212L/R-SA24015-20	1,5	10	20	12	12	110	-	-	●	SA24-15...
HSA 1212L/R-SA24015-26	1,5	13	26	12	12	110	22,5	-	●	SA24-15...
HSA 1212L/R-SA24015-32	1,5	16	32	12	12	110	26,0	16	●	SA24-15...
HSA 1212L/R-SA2402-20	2,0	10	20	12	12	110	-	-	●	SA24-20...
HSA 1212L/R-SA2402-26	2,0	13	26	12	12	110	-	-	●	SA24-20...
HSA 1212L/R-SA2402-32	2,0	16	32	12	12	110	26,0	16	●	SA24-20...
HSA 1212L/R-SA24025-26	2,5	13	26	12	12	110	22,5	-	●	SA24-25...
HSA 1212L/R-SA24025-32	2,5	16	32	12	12	110	26,0	16	●	SA24-25...
HSA 1616L/R-SA1602-20	2,0	10	20	16	16	110	-	-	●	SA16-20...
HSA 1616L/R-SA1602-26	2,0	13	26	16	16	110	-	-	●	SA16-20...
HSA 1616L/R-SA1603-26	3,0	13	26	16	16	110	-	-	●	SA16-30...
HSA 1616L/R-SA24015-32	1,5	16	32	16	16	110	-	-	●	SA24-15...
HSA 1616L/R-SA2402-26	2,0	13	26	16	16	110	-	-	●	SA24-20...
HSA 1616L/R-SA2402-32	2,0	16	32	16	16	110	-	-	●	SA24-20...
HSA 1616L/R-SA24025-32	2,5	16	32	16	16	110	-	-	●	SA24-25...
HSA 1616L/R-SA2403-20	3,0	10	20	16	16	110	-	-	●	SA24-30...
HSA 1616L/R-SA2403-26	3,0	13	26	16	16	110	-	-	●	SA24-30...
HSA 1616L/R-SA2403-32	3,0	16	32	16	16	110	-	-	●	SA24-30...
HSA 2020L/R-SA1603-26	3,0	13	26	20	20	110	22,5	-	●	SA16-30...
HSA 2020L/R-SA2402-20	2,0	10	20	20	20	110	-	-	●	SA24-20...
HSA 2020L/R-SA2402-32	2,0	16	32	20	20	110	25,5	20	●	SA24-20...
HSA 2020L/R-SA24025-26 N	2,5	13	26	20	20	110	23,0	20	●	SA24-25...
HSA 2020L/R-SA24025-32 N	2,5	16	32	20	20	110	26,0	20	●	SA24-25...
HSA 2020L/R-SA2403-32	3,0	16	32	20	20	110	-	-	●	SA24-30...

D_{max} = Maximaler Durchmesser bei Vollmaterial

D_{max} = Maximum diameter in solid

D_{max} = Diametro massimo lavorazione dal pieno

Ersatzteile / Spare Parts / Ricambi

Trägerwerkzeug Holder Utensile	Schraube Screw Vite	Schlüssel Key Chiave
HSA 0808..	AS 0022-12	T5215-IP
HSA 1010.. -HSA 2020..	AS 0022	T5215-IP

HSA

Für Traub TNL12 / For Traub TNL12 / Per Traub TNL12

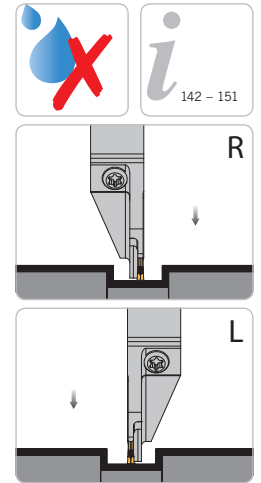
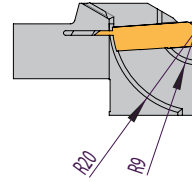
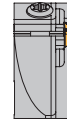
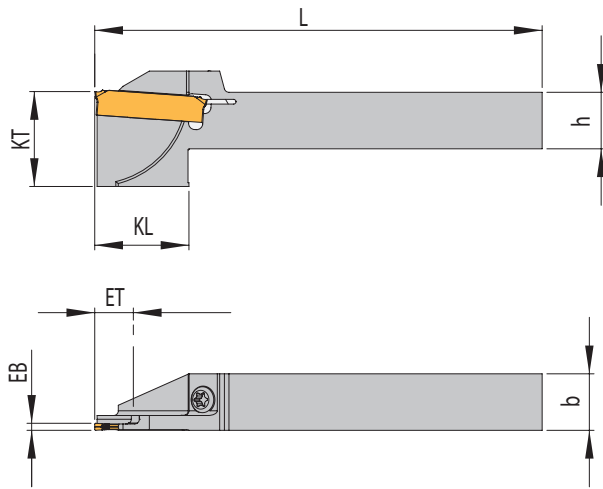

1

Rechte Ausführung abgebildet
Right-hand execution shown
Versione destra in figura

Trägerwerkzeuge / Holders / Utensili

Bezeichnung Designation Articolo	EB	ET	D _{max}	h	b	L	KL	KT	PG 37	Schneideinsatz Insert Inserto
HSA 1212R-SA24015-S1-16	1,5	8	16	12	12	95	20	12	●	SA24-15...

Ersatzteile / Spare Parts / Ricambi

Trägerwerkzeug Holder Utensile	Schraube Screw Vite	Schlüssel Key Chiave
HSA 1212.. -SA24015..	AS 0022	T5215-IP

HSA

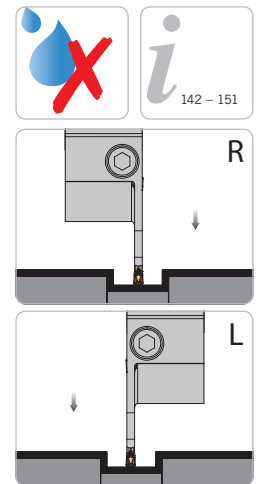
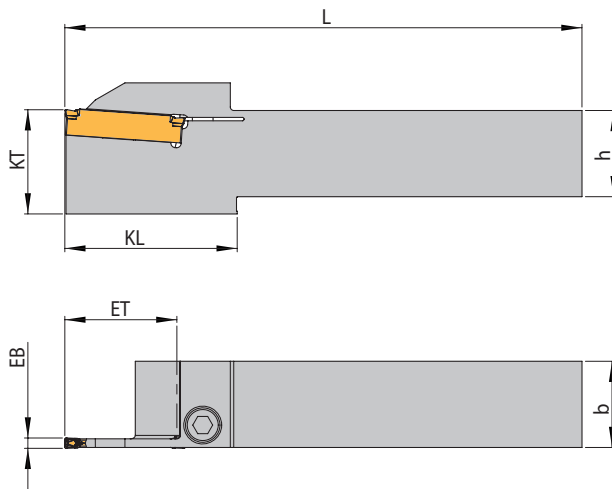

Rechte Ausführung abgebildet
Right-hand execution shown
Versione destra in figura

Trägerwerkzeuge / Holders / Utensili

Bezeichnung Designation Articolo	EB	ET	D _{max}	D _R	h	b	L	KL	KT	PG 37	Schneideinsatz Insert Inserto
HSA 1616L/R-SA24015-44	1,5	22,0	44	61	16	16	125	40	20	●	SA 24-15...
HSA 1616L/R-SA2402-44	2,0	22,0	44	61	16	16	125	40	20	●	SA 24-20...
HSA 1616L/R-SA2403-44	3,0	22,0	44	61	16	16	125	40	20	●	SA 24-30...
HSA 2020L/R-SA24015-44	1,5	22,0	44	61	20	20	125	-	-	●	SA 24-15...
HSA 2020L/R-SA2402-44	2,0	22,0	44	61	20	20	125	-	-	●	SA 24-20...
HSA 2020L/R-SA24025-44	2,5	22,0	44	61	20	20	125	-	-	●	SA 24-25...
HSA 2020L/R-SA2403-44	3,0	22,0	44	61	20	20	125	-	-	●	SA 24-30...
HSA 2020L/R-SA2404-44	4,0	22,0	44	61	20	20	125	-	-	●	SA 24-40...
HSA 2020L/R-SA3502-52	2,0	26,0	52	68	20	20	150	44	30	●	SA 35-20...
HSA 2020L/R-SA3502-65	2,0	32,5	65	80	20	20	150	50	30	●	SA 35-20...
HSA 2020L/R-SA3503-52	3,0	26,0	52	68	20	20	150	44	30	●	SA 35-30...
HSA 2020L/R-SA3503-65	3,0	32,5	65	80	20	20	150	50	30	●	SA 35-30...
HSA 2020L/R-SA3504-52	4,0	26,0	52	68	20	20	150	44	30	●	SA 35-40...
HSA 2020L/R-SA3504-65	4,0	32,5	65	80	20	20	150	50	30	●	SA 35-40...
HSA 2020L/R-SA3506-65	6,0	32,5	65	80	20	20	150	50	30	●	SA 35-60...
HSA 2525L/R-SA2402-44	2,0	22,0	44	61	25	25	150	-	-	●	SA 24-20...
HSA 2525L/R-SA2403-44	3,0	22,0	44	61	25	25	150	-	-	●	SA 24-30...
HSA 2525L/R-SA2404-44	4,0	22,0	44	61	25	25	150	-	-	●	SA 24-40...
HSA 2525L/R-SA2405-44	5,0	22,0	44	61	25	25	150	-	-	●	SA 24-50...
HSA 2525L/R-SA3502-52	2,0	26,0	52	68	25	25	150	44	30	●	SA 35-20...
HSA 2525L/R-SA3502-65	2,0	32,5	65	80	25	25	150	50	30	●	SA 35-20...
HSA 2525L/R-SA3503-52	3,0	26,0	52	68	25	25	150	44	30	●	SA 35-30...
HSA 2525L/R-SA3503-65	3,0	32,5	65	80	25	25	150	50	30	●	SA 35-30...
HSA 2525L/R-SA3504-52	4,0	26,0	52	68	25	25	150	44	30	●	SA 35-40...
HSA 2525L/R-SA3504-65	4,0	32,5	65	80	25	25	150	50	30	●	SA 35-40...
HSA 2525L/R-SA3506-65	6,0	32,5	65	80	25	25	150	50	30	●	SA 35-60...
HSA 2525L/R-SA3508-65	8,0	32,5	65	80	25	25	170	50	30	●	SA 35-80...
HSA 3225L/R-SA2403-44	3,0	22,0	44	61	32	25	170	-	-	●	SA 24-30...
HSA 3225L/R-SA2404-44	4,0	22,0	44	61	32	25	170	-	-	●	SA 24-40...
HSA 3225L/R-SA3503-65	3,0	32,5	65	80	32	25	170	50	32	●	SA 35-30...
HSA 3225L/R-SA3504-65	4,0	32,5	65	80	32	25	170	-	-	●	SA 35-40...
HSA 3232L/R-SA3506-65	6,0	32,5	65	80	32	32	170	-	-	●	SA 35-60...
HSA 3232L/R-SA3508-65	8,0	32,5	65	80	32	32	170	-	-	●	SA 35-80...
HSA 3232L/R-SA4010-75	10,0	37,5	75	90	32	32	170	-	-	●	SA 40-100...

D_{max} = Maximaler Durchmesser bei Vollmaterial, D_R = Maximaler Stechdurchmesser bei Rohren

D_{max} = Maximum diameter in solid, D_R = Maximum diameter for tube material

D_{max} = Diametro massimo lavorazione dal pieno, D_R = Diametro massimo da tubo

Ersatzteile / Spare Parts / Ricambi

Trägerwerkzeug Holder Utensile	Schraube Screw Vite	Schlüssel Key Chiave
HSA 1616.. -HSA 3225.. -SA24.. -44	DIN912 M5X16-12.9	KP 1321
HSA 2020.. -HSA 3232.. -SA35.. -52/65	DIN912 M6X20-12.9	KP 5421
HSA 3232.. -SA40.. -75	DIN912 M6X20-12.9	KP 5421

Holders for SA-Modules (MSA)
Adattatore per moduli SA (MSA)

HSA...7... – ohne ACS
HSA...7... – without ACS
HSA...7... – senza ACS

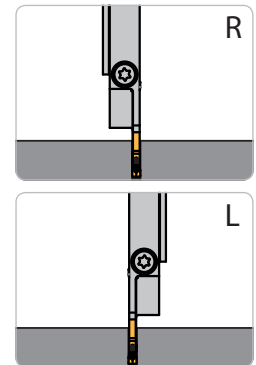
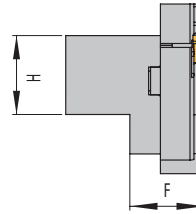
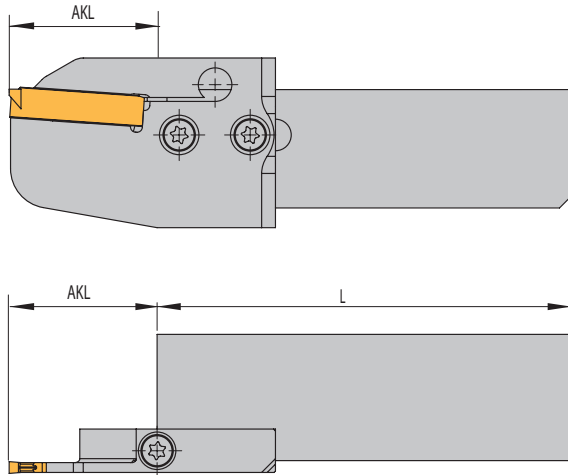

Rechter Halter und
rechtes Modul montiert
Right holder and right module shown
Adattatore destro e
modulo destro in figura

1

Halter für SA-Module (MSA) / Holders for SA-Modules (MSA) / Adattatore per moduli SA (MSA)

Bezeichnung Designation Articolo	H	L	PG 37
HSA 72032L	20	105	●
HSA 72032R	20	105	●
HSA-72536L	25	120	●
HSA-72536R	25	120	●

Hinweis: Halter HSA...7... werden mit Schraube und Schlüssel geliefert, jedoch ohne Modul.

Remark: Holders HSA-7... are supplied with screw and key, but without modules.

Nota: Adattatori HSA-7 sono forniti con vite e chiave, ma senza modulo.

Passende Module finden Sie ab Seite 122.

KMH-Werkzeughalter (VDI) finden Sie auf den Seiten 458 bis 477.

Suitable modules can be found starting on page 122

KMH holders (VDI) can be found on pages 458 to 477.

Per moduli compatibili vedere de pagina 122.

Adattatori KMH (VDI) vedere pagine 458 a 477.

Modul Designation Articolo	AKL	F
MSA-...-32	22,0	19,0
MSA-...-44	27,0	
MSA-...-52	37,5	
MSA-...-65	37,5	
MSA-...-80	45,0	
MSA-...-105	58,0	
MSA-...-125	68,0	
MSA-...-140	75,5	

HSA-S-ACS1-S2/S2G

Monoblockhalter mit Innenkühlung ACS1 von der Seite für Langdrehautomaten

Monoblock holder with through tool coolant (ACS1) access from the side for swiss type machines

Utensile monoblocco con adduzione interna ACS1 laterale per fantina mobile

1

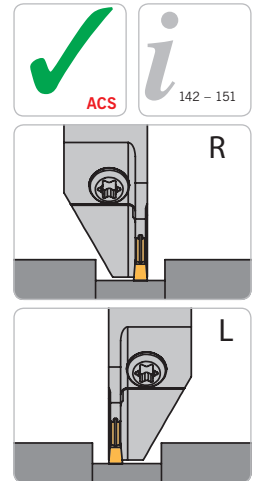
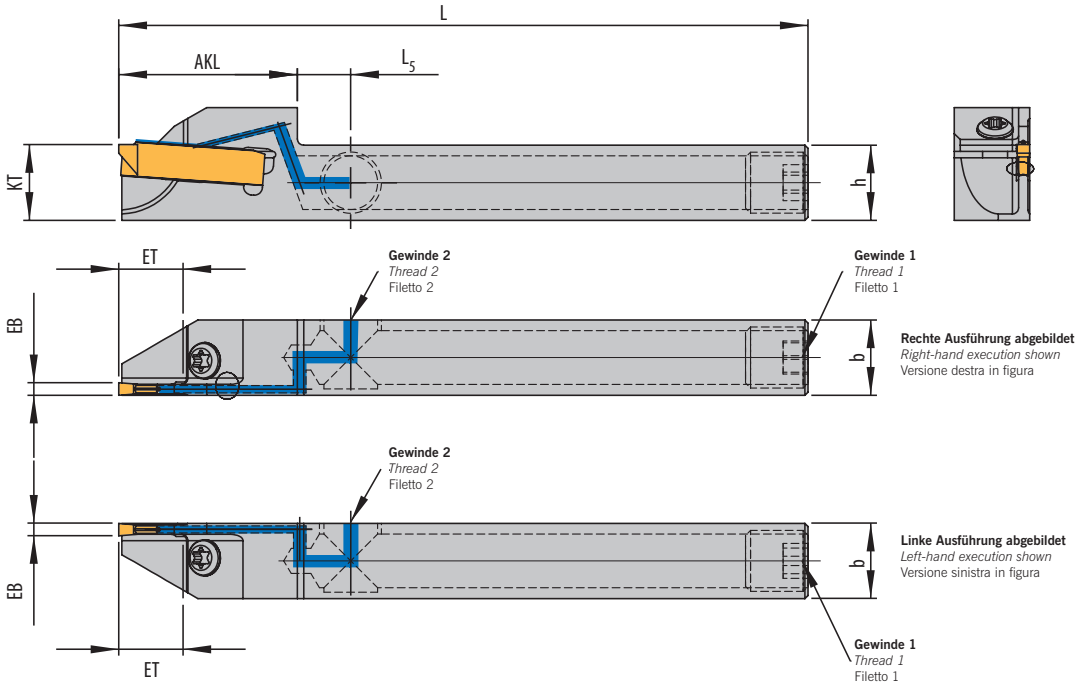

Trägerwerkzeuge / Holders / Utensili

Linke Ausführung, Kühlmittelanschluss auf der Seite der Schneide / Left hand execution, coolant access from the side of the cutting edge / Esecuzione sinistra, adduzione laterale da lato inserto

Bezeichnung Designation Articolo	EB	ET	D _{max}	h	b	L	L ₅	AKL	KT	Gewinde 1 Thread 1 Filetto 1	Gewinde 2 Thread 2 Filetto 2	PG 37	Schneideinsatz Insert Inserto
HSA 1212S-L-SA2402-20-ACS1-H2-S2	2,0	10	20	12	12	110	8,5	28,5	12	G 1/8"	G 1/8"	●	SA 24-20...
HSA 1212S-L-SA2402-26-ACS1-H2-S2	2,0	13	26	12	12	110	8,5	31,5	12	G 1/8"	G 1/8"	●	SA 24-20...
HSA 1616S-L-SA2402-32-ACS1-H2-S2	2,0	16	32	16	16	110	8,5	34,5	16	G 1/8"	G 1/8"	●	SA 24-20...
HSA 1616S-L-SA2402-36-ACS1-H2-S2	2,0	18	36	16	16	110	8,5	36,5	16	G 1/8"	G 1/8"	●	SA 24-20...
HSA 1616S-L-SA24025-32-ACS1-H2-S2	2,5	16	32	16	16	110	8,5	34,5	16	G 1/8"	G 1/8"	●	SA 24-25...
HSA 1616S-L-SA24025-36-ACS1-H2-S2	2,5	18	36	16	16	110	8,5	36,5	16	G 1/8"	G 1/8"	●	SA 24-25...
HSA 1616S-L-SA2403-32-ACS1-H2-S2	3,0	16	32	16	16	110	8,5	36,5	16	G 1/8"	G 1/8"	●	SA 24-30...
HSA 1616S-L-SA2403-36-ACS1-H2-S2	3,0	18	36	16	16	110	8,5	36,5	16	G 1/8"	G 1/8"	●	SA 24-30...

D_{max} = Maximaler Durchmesser bei Vollmaterial

D_{max} = Maximum diameter in solid

D_{max} = Diametro massimo lavorazione dal pieno

Rechte Ausführung, Kühlmittelanschluss auf der gegenüberliegenden Seite der Schneide / Right hand execution, coolant access from the opposite side of the cutting edge / Esecuzione destra, adduzione laterale dal lato opposto all'inserto

Bezeichnung Designation Articolo	EB	ET	D _{max}	h	b	L	L ₅	AKL	KT	Gewinde 1 Thread 1 Filetto 1	Gewinde 2 Thread 2 Filetto 2	PG 37	Schneideinsatz Insert Inserto
HSA 1212S-R-SA2402-20-ACS1-H2-S2G	2,0	10	20	12	12	110	8,5	28,5	12	G 1/8"	G 1/8"	●	SA 24-20...
HSA 1212S-R-SA2402-26-ACS1-H2-S2G	2,0	13	26	12	12	110	8,5	31,5	12	G 1/8"	G 1/8"	●	SA 24-20...
HSA 1616S-R-SA2402-32-ACS1-H2-S2G	2,0	16	32	16	16	110	8,5	34,5	16	G 1/8"	G 1/8"	●	SA 24-20...
HSA 1616S-R-SA2402-36-ACS1-H2-S2G	2,0	18	36	16	16	110	8,5	36,5	16	G 1/8"	G 1/8"	●	SA 24-20...
HSA 1616S-R-SA24025-32-ACS1-H2-S2G	2,5	16	32	16	16	110	8,5	34,5	16	G 1/8"	G 1/8"	●	SA 24-25...
HSA 1616S-R-SA24025-36-ACS1-H2-S2G	2,5	18	36	16	16	110	8,5	36,5	16	G 1/8"	G 1/8"	●	SA 24-25...

HSA-S-ACS1-S2/S2G

Rechte Ausführung, Kühlmittelschluss auf der gegenüberliegenden Seite der Schneide / Right hand execution, coolant access from the opposite side of the cutting edge / Esecuzione destra, adduzione laterale dal lato opposto all'inserto

Bezeichnung Designation Articolo	EB	ET	D _{max}	h	b	L	L ₅	AKL	KT	Gewinde 1 Thread 1 Filetto 1	Gewinde 2 Thread 2 Filetto 2	PG 37	Schneideinsatz Insert Inserto
HSA 1616S-R-SA2403-32-ACS1-H2-S2G	3,0	16	32	16	16	110	8,5	36,5	16	G 1/8"	G 1/8"	●	SA 24-30...
HSA 1616S-R-SA2403-36-ACS1-H2-S2G	3,0	18	36	16	16	110	8,5	36,5	16	G 1/8"	G 1/8"	●	SA 24-30...

D_{max} = Maximaler Durchmesser bei Vollmaterial

D_{max} = Maximum diameter in solid

D_{max} = Diametro massimo lavorazione dal pieno

ARNO® SpecialDesign

Diese Monoblockhalter bekommen Sie mit Ihren spezifischen Kühllanschlüssen. Ein Anfrageblatt hierzu finden Sie auf Seite 68 oder im Internet unter: www.arno.de/service/downloads

The coolant inlet can be supplied to your specification, please complete enquiry sheet on page 68 or download this from: www.arno.de/service/downloads

Questi corpi utensile sono fornibili con specifiche connessioni del refrigerante, Vedere modulo richiesta a Pag. 68 o download del modulo da: www.arno.de/service/downloads

Ersatzteile / Spare Parts / Ricambi

Trägerwerkzeug Holder Utensile	Schraube Screw Vite	Schlüssel Key Chiave
HSA 1212S.. -HSA1616S.. -SA24.. -ACS1..	AS 0022	T5215-IP

Zubehör / Accessories / Accessori

Bezeichnung Designation Articolo	A	B
KA 001 Kühlmittelschluss – gerade Coolant supply – straight Raccordo – dritto	M8x1	Ø 6 mm
KA 002	1/8"	Ø 6 mm
KA 003	1/4"	Ø 10 mm
KA 004 Kühlmittelschluss – winklig, fest Coolant supply – angled and fixed Raccordo – angolato	M8x1	Ø 6 mm
KA 005	1/8"	Ø 6 mm
KA 006 Schwenkverschraubung Swivelling screw-fitting Raccordo – orientabile	M8x1	Ø 6 mm
KA 007	1/8"	Ø 6 mm
KA 008	1/4"	Ø 10 mm

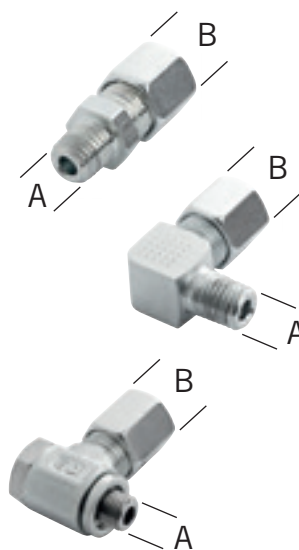

HSA-S-ACS1-S4/S4G

Monoblockhalter mit Innenkühlung ACS1 von der Seite für Langdrehautomaten

Monoblock holder with through tool coolant (ACS1) access from the side for swiss type machines
Utensile monoblocco con adduzione interna ACS1 laterale per fantina mobile

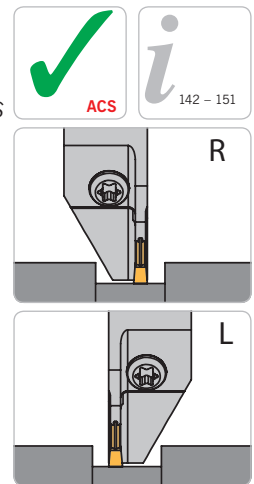

1

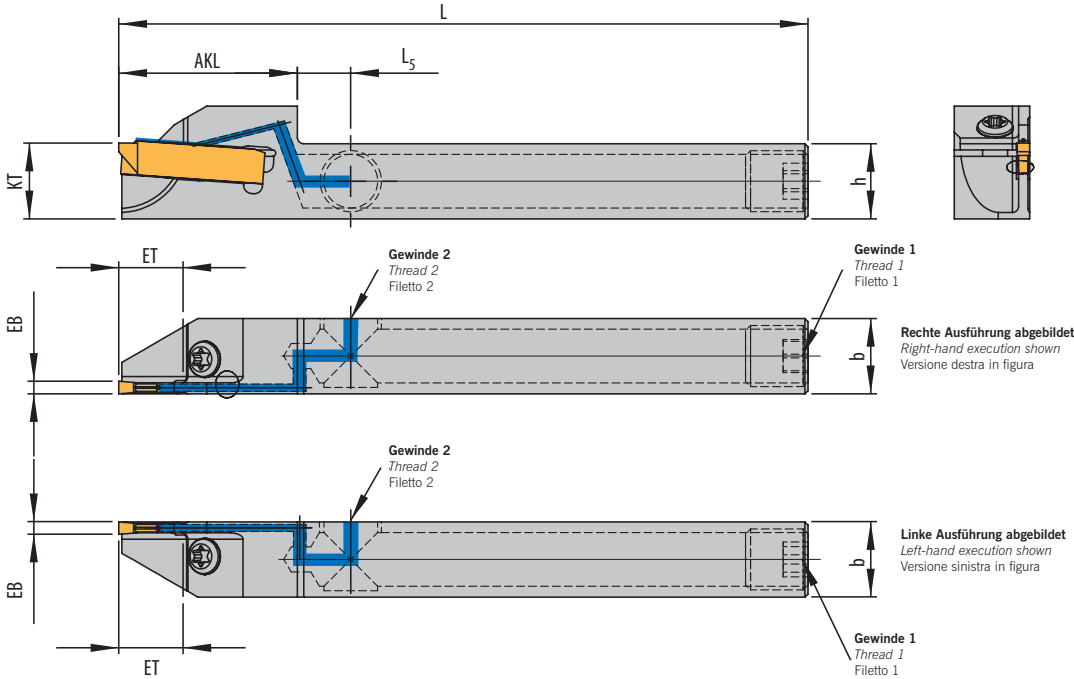

N NEU/NEW/NUOVO

Trägerwerkzeuge / Holders / Utensili

Linke Ausführung, Kühlmittelanschluss auf der Seite der Schneide / Left hand execution, coolant access from the side of the cutting edge / Esecuzione sinistra, adduzione laterale da lato inserto

Bezeichnung Designation Articolo	EB	ET	D _{max}	h	b	L	L ₅	AKL	KT	Gewinde 1 Thread 1 Filetto 1	Gewinde 2 Thread 2 Filetto 2	PG 37	Schneideinsatz Insert Inserto
HSA 1010S-L-SA2402-12-ACS1-H4-S4	2	6	12	10	10	110	8,5	24,5	10	UNF 5/16"x24	UNF 5/16"x24	●	SA 24-20...
HSA 1010S-L-SA2402-16-ACS1-H4-S4	2	8	16	10	10	110	8,5	26,5	10	UNF 5/16"x24	UNF 5/16"x24	●	SA 24-20...

D_{max} = Maximaler Durchmesser bei Vollmaterial
D_{max} = Maximum diameter in solid
D_{max} = Diametro massimo lavorazione dal pieno

Rechte Ausführung, Kühlmittelanschluss auf der gegenüberliegenden Seite der Schneide / Right hand execution, coolant access from the opposite side of the cutting edge / Esecuzione destra, adduzione laterale dal lato opposto all'inserto

Bezeichnung Designation Articolo	EB	ET	D _{max}	h	b	L	L ₅	AKL	KT	Gewinde 1 Thread 1 Filetto 1	Gewinde 2 Thread 2 Filetto 2	PG 37	Schneideinsatz Insert Inserto
HSA 1010S-R-SA2402-12-ACS1-H4-S4G	2	6	12	10	10	110	8,5	24,5	10	UNF 5/16"x24	UNF 5/16"x24	●	SA 24-20...
HSA 1010S-R-SA2402-16-ACS1-H4-S4G	2	8	16	10	10	110	8,5	26,5	10	UNF 5/16"x24	UNF 5/16"x24	●	SA 24-20...

D_{max} = Maximaler Durchmesser bei Vollmaterial
D_{max} = Maximum diameter in solid
D_{max} = Diametro massimo lavorazione dal pieno

Ersatzteile / Spare Parts / Ricambi

Trägerwerkzeug Holder Utensile	Schraube Screw Vite	Schlüssel Key Chiave
HSA 1010S.. -SA24.. -ACS1..	AS 0022	T5215-IP

HSA-UD-ACS1-S./S.G.

Monoblockhalter mit Innenkühlung ACS1 von der Seite - Spannung von oben und unten

Monoblock holder with through tool coolant (ACS1) access from the side - Locking from top and bottom

Utensile monoblocco con adduzione interna ACS1 laterale - Bloccaggio da sopra e sotto

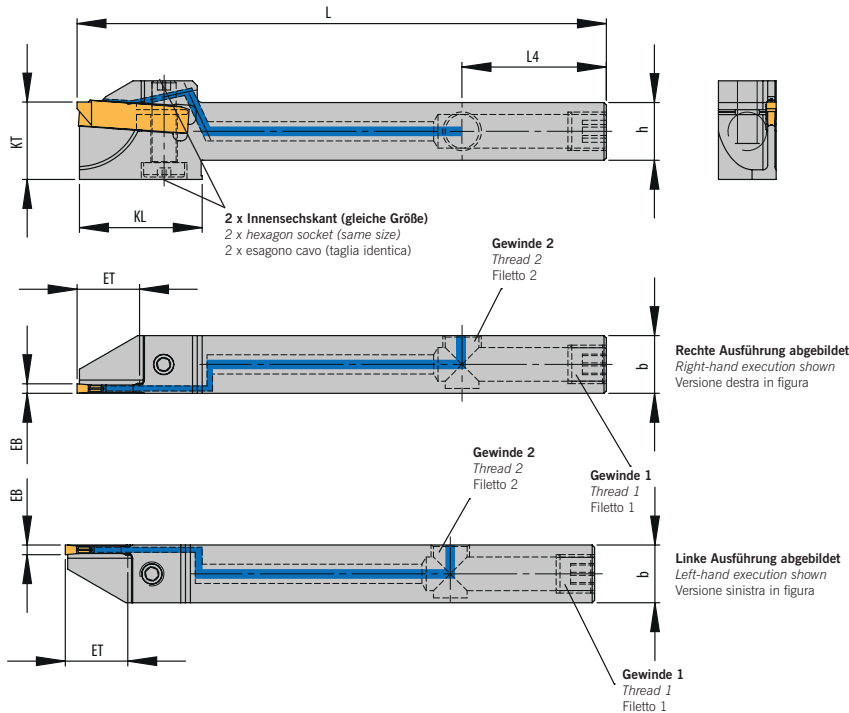
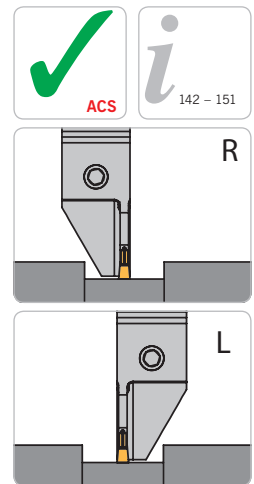

Trägerwerkzeuge / Holders / Utensili

Linke Ausführung, Kühlmittelanschluss auf der Seite der Schneide / Left hand execution, coolant access from the side of the cutting edge /
Esecuzione sinistra, adduzione laterale da lato inserto

Bezeichnung Designation Articolo	EB	ET	D _{max}	h	b	L	L ₄	KL	KT	Gewinde 1 Thread 1 Filetto 1	Gewinde 2 Thread 2 Filetto 2	PG 37	Schneideinsatz Insert Inserto
HSA 1212UD-L-SA2402-26-ACS1-S1	2	13	26	12	12	110	30	26	16	M8x1	M8x1	●	SA 24-20...
HSA 1212UD-L-SA2402-26-ACS1-S2	2	13	26	12	12	110	30	26	16	M8x1	G 1/8"	●	SA 24-20...

D_{max} = Maximaler Durchmesser bei Vollmaterial
D_{max} = Maximum diameter in solid
D_{max} = Diametro massimo lavorazione dal pieno

Rechte Ausführung, Kühlmittelanschluss auf der gegenüberliegenden Seite der Schneide / Right hand execution, coolant access from the opposite side of the cutting edge /
Esecuzione destra, adduzione laterale dal lato opposto all'inserto

Bezeichnung Designation Articolo	EB	ET	D _{max}	h	b	L	L ₄	KL	KT	Gewinde 1 Thread 1 Filetto 1	Gewinde 2 Thread 2 Filetto 2	PG 37	Schneideinsatz Insert Inserto
HSA 1212UD-R-SA2402-26-ACS1-S1G	2	13	26	12	12	110	30	26	16	M8x1	M8x1	●	SA 24-20...
HSA 1212UD-R-SA2402-26-ACS1-S2G	2	13	26	12	12	110	30	26	16	M8x1	G 1/8"	●	SA 24-20...

D_{max} = Maximaler Durchmesser bei Vollmaterial
D_{max} = Maximum diameter in solid
D_{max} = Diametro massimo lavorazione dal pieno

Ersatzteile / Spare Parts / Ricambi

Trägerwerkzeug Holder Utensile	Schraube Screw Vite	Schlüssel Key Chiave
HSA 1212UD..	AS 0084	KP 3111

Kühlmittelanschlüsse finden Sie auf Seite 65
Coolant supply can be found on page 65
Raccordo vedere pagina 65

Monoblockhalter mit Innenkühlung von hinten und Spannung von oben und unten



1

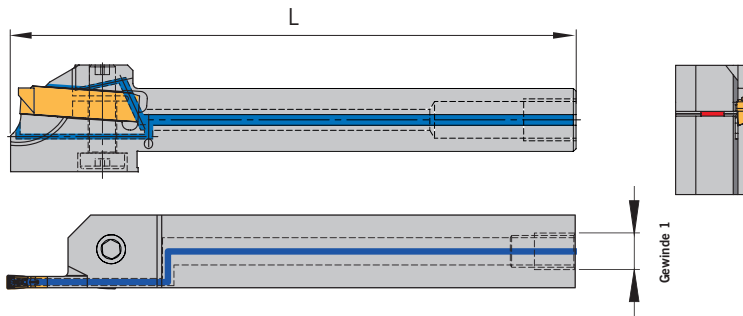

Aus Halter	M8 x1	G1/8"	G1/4"	L
------------	-------	-------	-------	---

Diese Halter fertigen wir Ihnen zum Preis des Standardwerkzeuges.

Monoblockhalter mit Innenkühlung von der Seite und Spannung von oben und unten

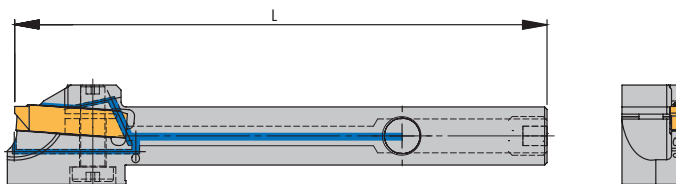

Ausführung S1. – Das Gewinde 2 ist auf der gleichen Seite wie die Schneide
– Spannung von oben und unten

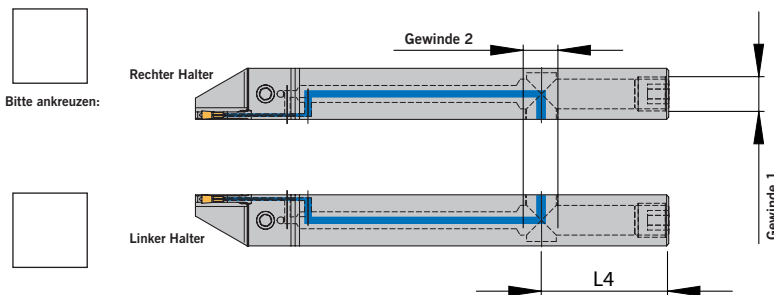

Ausführung S1G. – Das Gewinde 2 ist gegenüber der Schneide
– Spannung von oben und unten

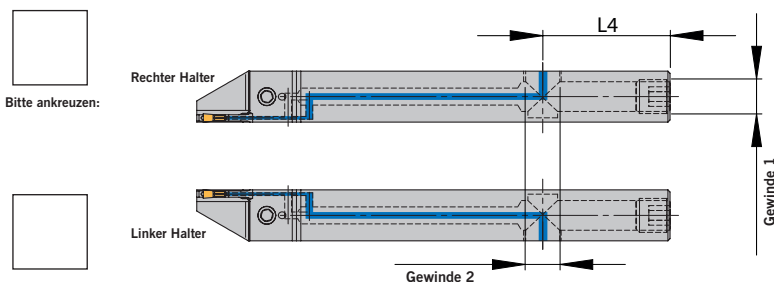

Aus Halter	M8 x1	G1/8"	M8 x1	G1/8"	L ₄	L
------------	-------	-------	-------	-------	----------------	---

Download dieses Formulares unter: www.arno.de/service/downloads

Monoblock holder with through tool coolant access from the back and locking from top and bottom

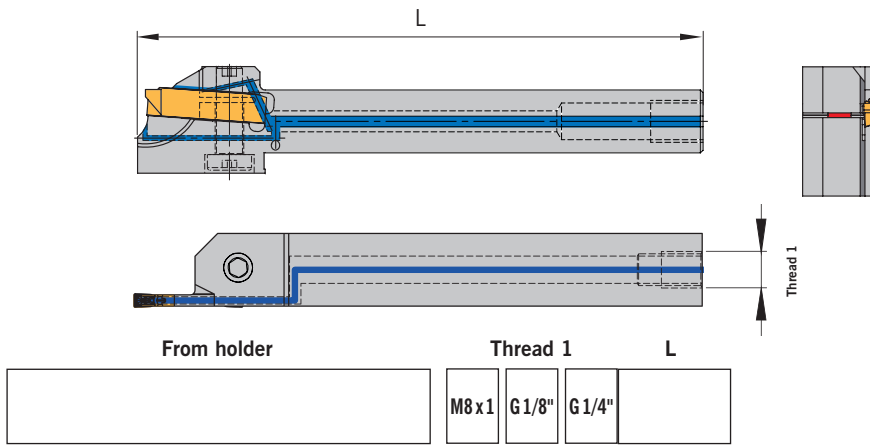

Monoblock holder with through tool coolant access from the side and locking from top and bottom

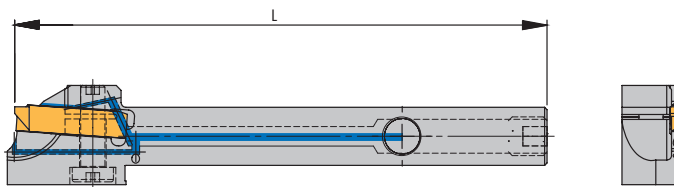

Design S1. – Thread 2 is on the same side as the cutting edge
– Locking from top and bottom

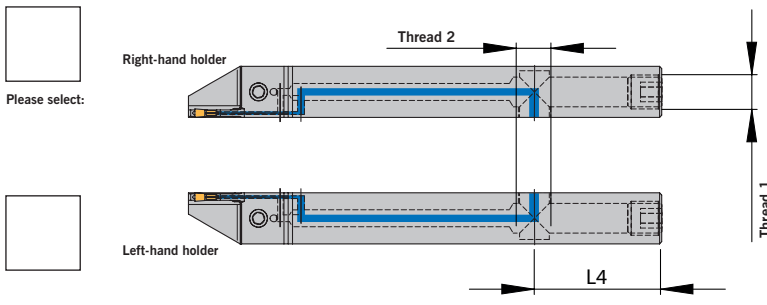

Design S1G. – Thread 2 is on the opposite side of the cutting edge
– Locking from top and bottom

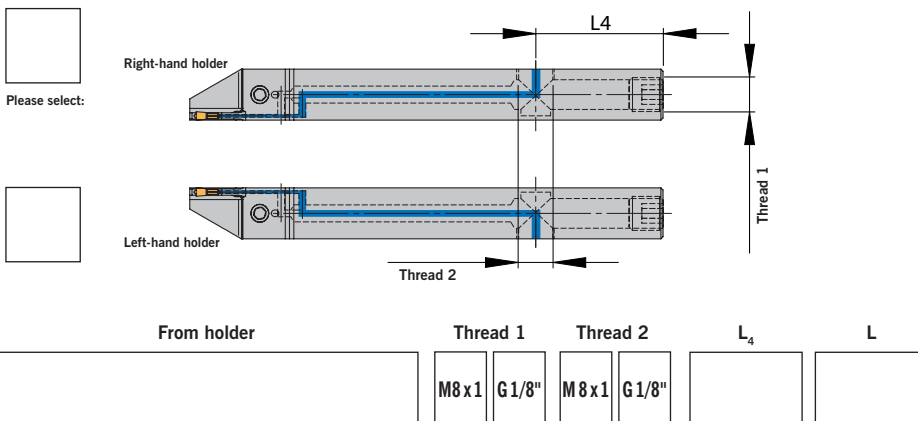

Download this form from: www.arno.de/service/downloads



1

This tool we produce to the price of the standard tool.

Utensile monoblocco con adduzione interna e bloccaggio da sopra e sotto



1

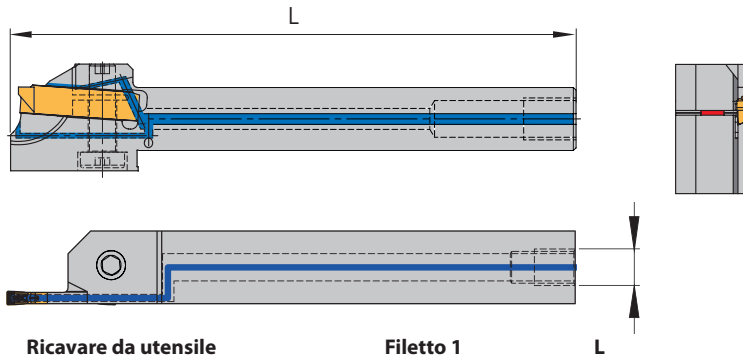

Questi utensili vengono realizzati al prezzo dello standard.

Ricavare da utensile	Filetto 1	L
<input type="text"/>	M8x1 G1/8" G1/4"	<input type="text"/>

Utensile monoblocco con adduzione laterale e bloccaggio da sopra e sotto

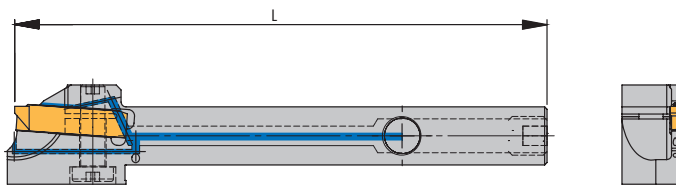

Versione S1. – Filettatura 2 sul medesimo lato dell'inserto
– Bloccaggio da sopra e sotto

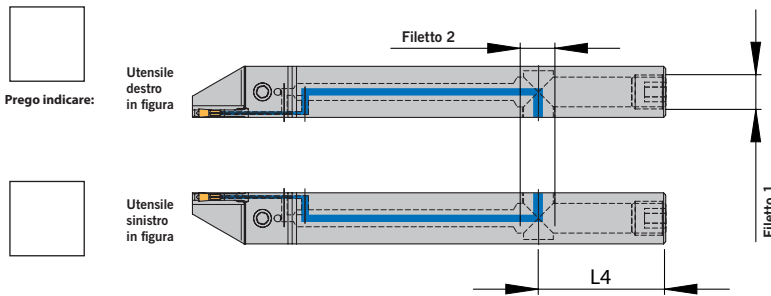

Versione S1G. – Filettatura 2 sul lato opposto l'inserto
– Bloccaggio da sopra e sotto

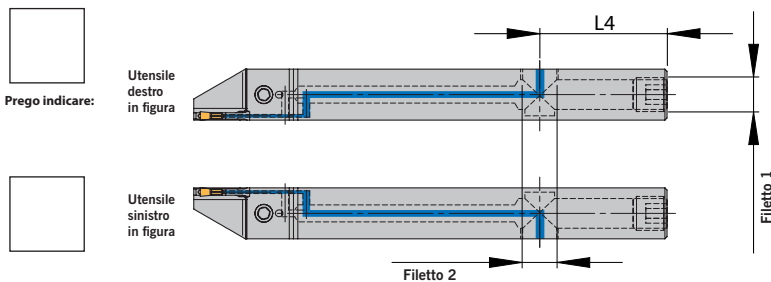

Ricavare da utensile	Filetto 1	Filetto 2	L ₄	L
<input type="text"/>	M8x1 G1/8"	M8x1 G1/8"	<input type="text"/>	<input type="text"/>

Download del modulo da: www.arno.de/service/downloads

HSA-ACS1-S.

Monoblockhalter mit Innenkühlung ACS1 von der Seite

Monoblock holder with through tool coolant (ACS1) access from the side
Utensile monoblocco con adduzione interna ACS1 laterale

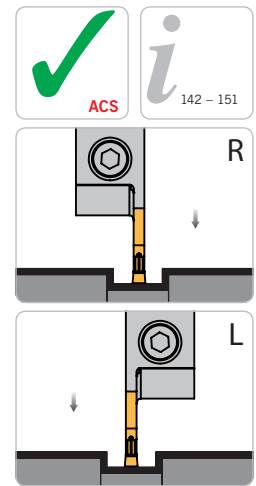
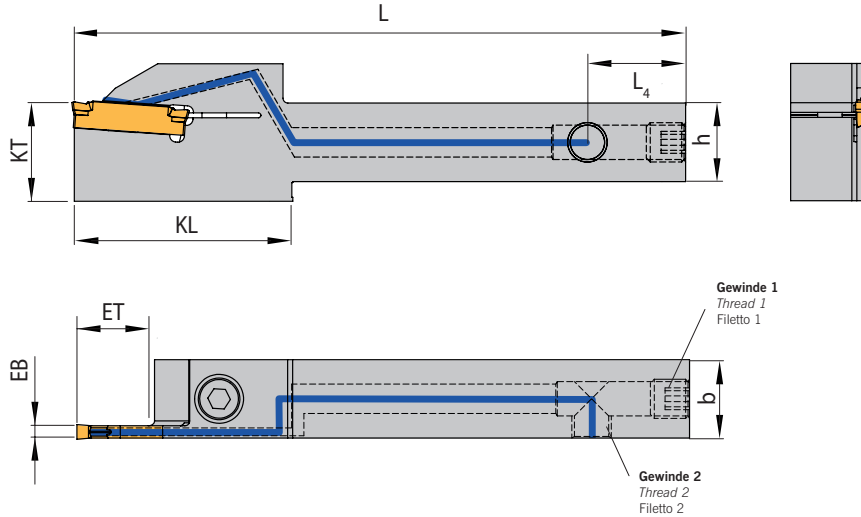

1

Rechte Ausführung abgebildet
Right-hand execution shown
Versione destra in figura

Trägerwerkzeuge / Holders / Utensili

Ausführung S1 = Gewinde 1: M8x1, Gewinde 2: M8x1 / Execution S1 = Thread 1 M8x1, Thread 2 M8x1 /
Esecuzione S1 = filetto 1 M8x1, filetto 2 M8x1

Bezeichnung Designation Articolo	EB	ET	D _{max}	D _R	h	b	L	L ₄	KL	KT	Gewinde 1 Thread 1 Filetto 1	Gewinde 2 Thread 2 Filetto 2	PG 37	Schneideinsatz Insert Inserto
HSA 1616L/R-SA2402-32-ACS1-S1	2,0	16,0	32	-	16	16	125	-	38	20	M8x1	M8x1	●	SA 24-20...
HSA 1616L/R-SA2403-32-ACS1-S1	3,0	16,0	32	-	16	16	125	20	38	20	M8x1	M8x1	●	SA 24-30...
HSA 1616L/R-SA2403-44-ACS1-S1	3,0	22,0	44	61	16	16	125	20	45	20	M8x1	M8x1	●	SA 24-30...
HSA 2020L/R-SA24025-44-ACS1-S1	2,5	22,0	44	61	20	20	125	-	-	-	M8x1	M8x1	●	SA 24-25...
HSA 2020L/R-SA2403-32-ACS1-S1	3,0	16,0	32	-	20	20	125	20	-	-	M8x1	M8x1	●	SA 24-30...
HSA 2020L/R-SA2403-44-ACS1-S1	3,0	22,0	44	61	20	20	125	20	-	-	M8x1	M8x1	●	SA 24-30...
HSA 2020L/R-SA3503-52-ACS1-S1	3,0	26,0	52	68	20	20	150	20	44	30	M8x1	M8x1	●	SA 35-30...
HSA 2020L/R-SA3503-65-ACS1-S1	3,0	32,5	65	80	20	20	150	20	50	30	M8x1	M8x1	●	SA 35-30...
HSA 2525L/R-SA2403-44-ACS1-S1	3,0	22,0	44	61	25	25	150	20	-	-	M8x1	M8x1	●	SA 24-30...
HSA 2525L/R-SA3503-52-ACS1-S1	3,0	26,0	52	68	25	25	150	20	44	30	M8x1	M8x1	●	SA 35-30...
HSA 2525L/R-SA3503-65-ACS1-S1	3,0	32,5	65	80	25	25	150	20	50	30	M8x1	M8x1	●	SA 35-30...

D_{max} = Maximaler Durchmesser bei Vollmaterial, D_R = Maximaler Stechdurchmesser bei Rohren

D_{max} = Maximum diameter in solid, D_R = Maximum diameter for tube material

D_{max} = Diametro massimo lavorazione dal pieno, D_R = Diametro massimo da tubo

Hinweis: Zubehör muss separat bestellt werden, s. Seite 142.

Remark: Accessories must be ordered separately, please see page 142.

Nota: Gli accessori devono essere ordinati separatamente, vedere pagina 142.

Ausführung S2 = Gewinde 1: M8x1, Gewinde 2: G1/8" / Execution S2 = Thread 1: M8x1, Thread 2: G1/8" /
Esecuzione S2 = filetto 1: M8x1, filetto 2: G1/8"

Bezeichnung Designation Articolo	EB	ET	D _{max}	D _R	h	b	L	L ₄	KL	KT	Gewinde 1 Thread 1 Filetto 1	Gewinde 2 Thread 2 Filetto 2	PG 37	Schneideinsatz Insert Inserto
HSA 1616L/R-SA2402-32-ACS1-S2	2,0	16,0	32	-	16	16	125	-	38	20	M8x1	G1/8"	●	SA 24-20...
HSA 1616L/R-SA2403-32-ACS1-S2	3,0	16,0	32	-	16	16	125	20	38	20	M8x1	G1/8"	●	SA 24-30...
HSA 1616L/R-SA2403-44-ACS1-S2	3,0	22,0	44	61	16	16	125	20	45	20	M8x1	G1/8"	●	SA 24-30...
HSA 2020L/R-SA24025-44-ACS1-S2	2,5	22,0	44	61	20	20	125	-	-	-	M8x1	G1/8"	●	SA 24-25...
HSA 2020L/R-SA2403-32-ACS1-S2	3,0	16,0	32	-	20	20	125	20	-	-	M8x1	G1/8"	●	SA 24-30...
HSA 2020L/R-SA2403-44-ACS1-S2	3,0	22,0	44	61	20	20	125	20	-	-	M8x1	G1/8"	●	SA 24-30...
HSA 2020L/R-SA3503-52-ACS1-S2	3,0	26,0	52	68	20	20	150	20	44	30	M8x1	G1/8"	●	SA 35-30...

HSA-ACS1-S.

Ausführung S2 = Gewinde 1: M8x1, Gewinde 2: G1/8" / Execution S2 = Thread 1: M8x1, Thread 2: G1/8" /
Esecuzione S2 = filetto 1: M8x1, filetto 2: G1/8"

Bezeichnung Designation Articolo	EB	ET	D _{max}	D _R	h	b	L	L ₄	KL	KT	Gewinde 1 Thread 1 Filetto 1	Gewinde 2 Thread 2 Filetto 2	PG 37	Schneideinsatz Insert Inserto
HSA 2020L/R-SA3503-65-ACS1-S2	3,0	32,5	65	80	20	20	150	20	50	30	M8x1	G1/8"	●	SA 35-30...
HSA 2525L/R-SA2403-44-ACS1-S2	3,0	22,0	44	61	25	25	150	20	-	-	M8x1	G1/8"	●	SA 24-30...
HSA 2525L/R-SA3503-52-ACS1-S2	3,0	26,0	52	68	25	25	150	20	44	30	M8x1	G1/8"	●	SA 35-30...
HSA 2525L/R-SA3503-65-ACS1-S2	3,0	32,5	65	80	25	25	150	20	50	30	M8x1	G1/8"	●	SA 35-30...

ARNO® SpecialDesign

Diese Monoblockhalter bekommen Sie mit Ihren spezifischen Kühllanschlüssen. Ein Anfrageblatt hierzu finden Sie auf Seite 75 oder im Internet unter: www.arno.de/service/downloads

The coolant inlet can be supplied to your specification, please complete enquiry sheet on page 75 or download this from: www.arno.de/service/downloads

Questi corpi utensile sono fornibili con specifiche connessioni del refrigerante, Vedere modulo richiesta a Pag. 75 o download del modulo da: www.arno.de/service/downloads

Ersatzteile / Spare Parts / Ricambi

Trägerwerkzeug Holder Utensile	Schraube Screw Vite	Schlüssel Key Chiave
HSA 1616.. -HSA 2525.. -SA24.. -ACS1..	DIN912 M5X16-12.9	KP 1321
HSA 2020.. -HSA 2525.. -SA35.. -ACS1..	DIN912 M6X20-12.9	KP 5421

Zubehör / Accessories / Accessori

Bezeichnung Designation Articolo	A	B
KA 001 Kühlmittelanschluss – gerade Coolant supply – straight Raccordo – dritto	M8x1	Ø 6 mm
KA 002	1/8"	Ø 6 mm
KA 003	1/4"	Ø 10 mm
KA 004 Kühlmittelanschluss – winklig, fest Coolant supply – angled and fixed Raccordo – angolato	M8x1	Ø 6 mm
KA 005	1/8"	Ø 6 mm
KA 006 Schwenkverschraubung Swivelling screw-fitting Raccordo – orientabile	M8x1	Ø 6 mm
KA 007	1/8"	Ø 6 mm
KA 008	1/4"	Ø 10 mm

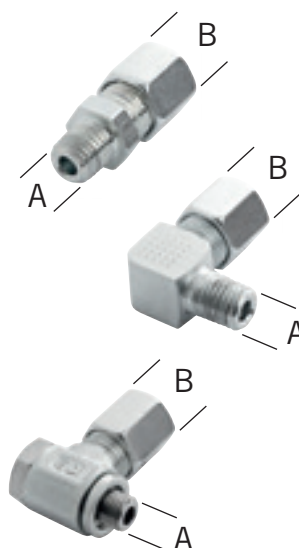

HSA-ACS1-H.

Monoblockhalter mit Innenkühlung ACS1 von hinten

Monoblock holder with through tool coolant (ACS1) access from the back
Utensile monoblocco con adduzione interna ACS1 posteriore

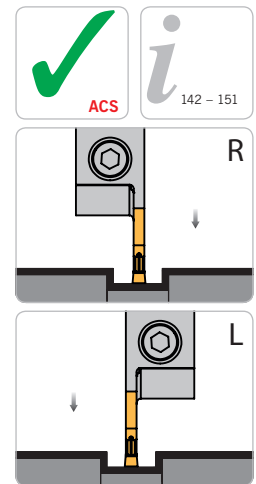
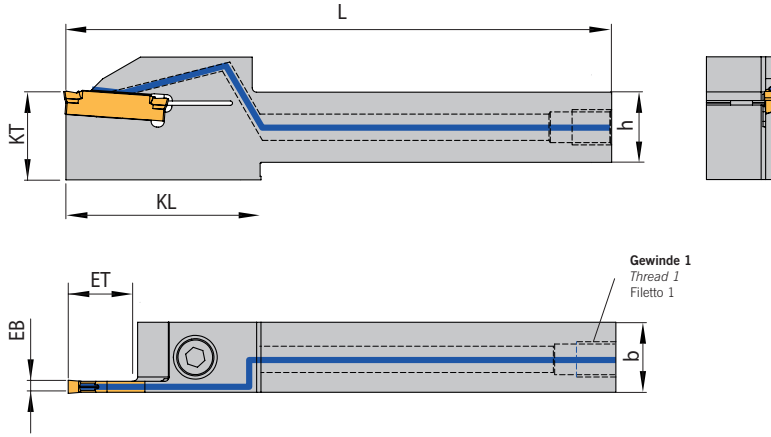

1

Rechte Ausführung abgebildet
Right-hand execution shown
Versione destra in figura



Trägerwerkzeuge / Holders / Utensili

Ausführung H1 = Gewinde M8x1 / Execution H1 = Thread M8x1 / Esecuzione H1 = filetto M8x1

Bezeichnung Designation Articolo	EB	ET	D _{max}	D _R	h	b	L	KL	KT	Gewinde 1 Thread 1 Filetto 1	PG 37	Schneideinsatz Insert Inserto
HSA 1616L/R-SA2402-32-ACS1-H1	2,0	16,0	32	-	16	16	125	38	20	M8x1	●	SA 24-20...
HSA 1616L/R-SA2403-32-ACS1-H1	3,0	16,0	32	-	16	16	125	38	20	M8x1	●	SA 24-30...
HSA 1616L/R-SA2403-44-ACS1-H1	3,0	22,0	44	61	16	16	125	45	20	M8x1	●	SA 24-30...
HSA 2020L/R-SA24025-32-ACS1-H1	2,5	16,0	32	-	20	20	125	36	20	M8x1	●	SA24-25...
HSA 2020L/R-SA24025-44-ACS1-H1	2,5	22,0	44	61	20	20	125	-	-	M8x1	●	SA24-25...
HSA 2020L/R-SA2403-32-ACS1-H1	3,0	16,0	32	-	20	20	125	-	-	M8x1	●	SA 24-30...
HSA 2020L/R-SA2403-44-ACS1-H1	3,0	22,0	44	61	20	20	125	-	-	M8x1	●	SA 24-30...
HSA 2020L/R-SA3503-52-ACS1-H1	3,0	26,0	52	68	20	20	150	44	30	M8x1	●	SA 35-30...
HSA 2020L/R-SA3503-65-ACS1-H1	3,0	32,5	65	80	20	20	150	50	30	M8x1	●	SA 35-30...
HSA 2525L/R-SA2403-44-ACS1-H1	3,0	22,0	44	61	25	25	150	-	-	M8x1	●	SA 24-30...
HSA 2525L/R-SA3503-52-ACS1-H1	3,0	26,0	52	68	25	25	150	44	30	M8x1	●	SA 35-30...
HSA 2525L/R-SA3503-65-ACS1-H1	3,0	32,5	65	80	25	25	150	50	30	M8x1	●	SA 35-30...

D_{max} = Maximaler Durchmesser bei Vollmaterial, D_R = Maximaler Stechdurchmesser bei Rohren

D_{max} = Maximum diameter in solid, D_R = Maximum diameter for tube material

D_{max} = Diametro massimo lavorazione dal pieno, D_R = Diametro massimo da tubo

Hinweis: Zubehör muss separat bestellt werden, s. Seite 142.

Remark: Accessories must be ordered separately, please see page 142.

Nota: Gli accessori devono essere ordinati separatamente, vedere pagina 142.

Ausführung H2 = Gewinde G1/8" / Execution H2 = Thread G1/8" / Esecuzione H2 = filetto G1/8"

Bezeichnung Designation Articolo	EB	ET	D _{max}	D _R	h	b	L	KL	KT	Gewinde 1 Thread 1 Filetto 1	PG 37	Schneideinsatz Insert Inserto
HSA 1616L/R-SA2402-32-ACS1-H2	2,0	16,0	32	-	16	16	125	38	20	G 1/8"	●	SA 24-20...
HSA 1616L/R-SA2403-32-ACS1-H2	3,0	16,0	32	-	16	16	125	38	20	G1/8"	●	SA 24-30...
HSA 1616L/R-SA2403-44-ACS1-H2	3,0	22,0	44	61	16	16	125	45	20	G1/8"	●	SA 24-30...
HSA 2020L/R-SA24025-44-ACS1-H2	2,5	22,0	44	61	20	20	125	-	-	G 1/8"	●	SA 24-25...
HSA 2020L/R-SA2403-32-ACS1-H2	3,0	16,0	32	-	20	20	125	-	-	G1/8"	●	SA 24-30...
HSA 2020L/R-SA2403-44-ACS1-H2	3,0	22,0	44	61	20	20	125	-	-	G1/8"	●	SA 24-30...
HSA 2020L/R-SA3503-52-ACS1-H2	3,0	26,0	52	68	20	20	150	44	30	G1/8"	●	SA 35-30...
HSA 2020L/R-SA3503-65-ACS1-H2	3,0	32,5	65	80	20	20	150	50	30	G1/8"	●	SA 35-30...
HSA 2525L/R-SA2403-44-ACS1-H2	3,0	22,0	44	61	25	25	150	-	-	G1/8"	●	SA 24-30...
HSA 2525L/R-SA3503-52-ACS1-H2	3,0	26,0	52	68	25	25	150	44	30	G1/8"	●	SA 35-30...
HSA 2525L/R-SA3503-65-ACS1-H2	3,0	32,5	65	80	25	25	150	50	30	G1/8"	●	SA 35-30...

D_{max} = Maximaler Durchmesser bei Vollmaterial, D_R = Maximaler Stechdurchmesser bei Rohren

D_{max} = Maximum diameter in solid, D_R = Maximum diameter for tube material

D_{max} = Diametro massimo lavorazione dal pieno, D_R = Diametro massimo da tubo

HSA-ACS1-H.

Ausführung H3 = Gewinde G1/4" / Execution H3 = Thread G1/4" / Esecuzione H3 = filetto G1/4"

Bezeichnung Designation Articolo	EB	ET	D _{max}	D _R	h	b	L	KL	KT	Gewinde 1 Thread 1 Filetto 1	PG 37	Schneideinsatz Insert Inserto
HSA 1616L/R-SA2402-32-ACS1-H3	2,0	16,0	32	-	16	16	125	38	20	G 1/4"	●	SA 24-20...
HSA 1616L/R-SA2403-32-ACS1-H3	3,0	16,0	32	-	16	16	125	38	20	G1/4"	●	SA 24-30...
HSA 1616L/R-SA2403-44-ACS1-H3	3,0	22,0	44	61	16	16	125	45	20	G1/4"	●	SA 24-30...
HSA 2020L/R-SA24025-44-ACS1-H3	2,5	22,0	44	61	20	20	125	-	-	G 1/4"	●	SA 24-25...
HSA 2020L/R-SA2403-32-ACS1-H3	3,0	16,0	32	-	20	20	125	-	-	G1/4"	●	SA 24-30...
HSA 2020L/R-SA2403-44-ACS1-H3	3,0	22,0	44	61	20	20	125	-	-	G1/4"	●	SA 24-30...
HSA 2020L/R-SA3503-52-ACS1-H3	3,0	26,0	52	68	20	20	150	44	30	G1/4"	●	SA 35-30...
HSA 2020L/R-SA3503-65-ACS1-H3	3,0	32,5	65	80	20	20	150	50	30	G1/4"	●	SA 35-30...
HSA 2525L/R-SA2403-44-ACS1-H3	3,0	22,0	44	61	25	25	150	-	-	G1/4"	●	SA 24-30...
HSA 2525L/R-SA3503-52-ACS1-H3	3,0	26,0	52	68	25	25	150	44	30	G1/4"	●	SA 35-30...
HSA 2525L/R-SA3503-65-ACS1-H3	3,0	32,5	65	80	25	25	150	50	30	G1/4"	●	SA 35-30...

D_{max} = Maximaler Durchmesser bei Vollmaterial, D_R = Maximaler Stechdurchmesser bei Rohren

D_{max} = Maximum diameter in solid, D_R = Maximum diameter for tube material

D_{max} = Diametro massimo lavorazione dal pieno, D_R = Diametro massimo da tubo

Hinweis: Zubehör muss separat bestellt werden.

Remark: Accessories must be ordered separately.

Nota: Gli accessori devono essere ordinati separatamente.

ARNO® SpecialDesign

Diese Monoblockhalter bekommen Sie mit Ihren spezifischen Kühllanschlüssen. Ein Anfrageblatt hierzu finden Sie auf Seite 75 oder im Internet unter: www.arno.de/service/downloads

The coolant inlet can be supplied to your specification, please complete enquiry sheet on page 75 or download this from: www.arno.de/service/downloads

Questi corpi utensile sono fornibili con specifiche connessioni del refrigerante, Vedere modulo richiesta a Pag. 75 o download del modulo da: www.arno.de/service/downloads

Ersatzteile / Spare Parts / Ricambi

Trägerwerkzeug Holder Utensile	Schraube Screw Vite	Schlüssel Key Chiave
HSA 1616.. -HSA 2525.. -SA24.. -ACS1..	DIN912 M5X16-12.9	KP 1321
HSA 2020.. -HSA 2525.. -SA35.. -ACS1..	DIN912 M6X20-12.9	KP 5421

Zubehör / Accessories / Accessori

Bezeichnung Designation Articolo	A	B
KA 001	M8x1	Ø 6 mm
KA 002	1/8"	Ø 6 mm
KA 003	1/4"	Ø 10 mm
KA 004	M8x1	Ø 6 mm
KA 005	1/8"	Ø 6 mm
KA 006	M8x1	Ø 6 mm
KA 007	1/8"	Ø 6 mm
KA 008	1/4"	Ø 10 mm

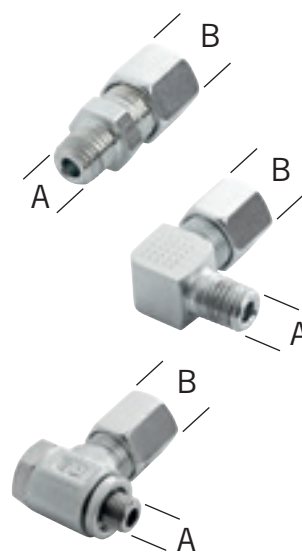

Monoblockhalter mit Innenkühlung ACS1 von hinten

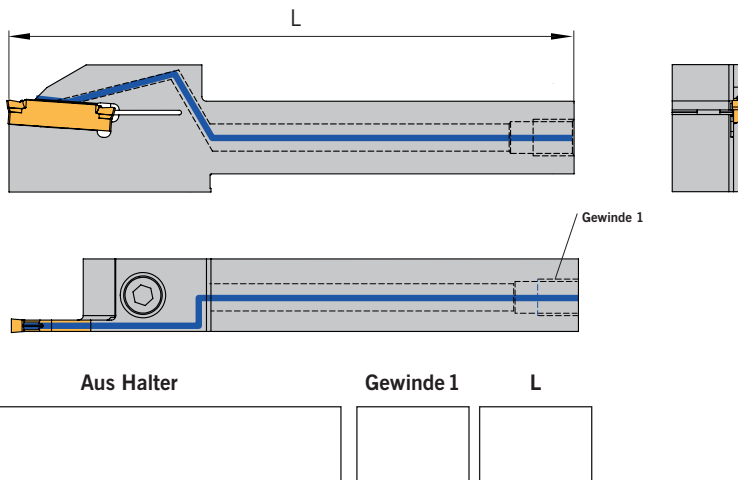

1

Diese Halter fertigen wir Ihnen zum Preis des Standardwerkzeuges.

Monoblockhalter mit Innenkühlung ACS1 von der Seite

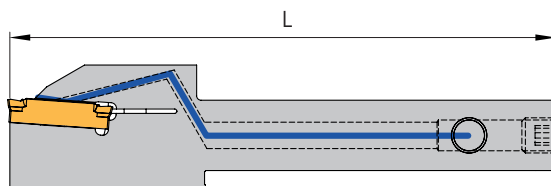

Bitte ankreuzen:

Ausführung S. – Das Gewinde 2 ist auf der gleichen Seite wie die Schneide

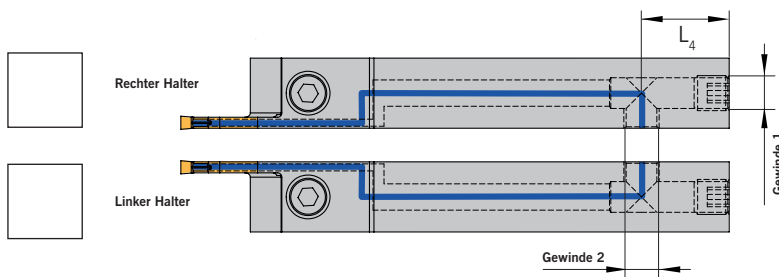

Ausführung SG. – Das Gewinde 2 ist gegenüber der Schneide

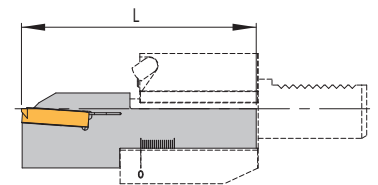
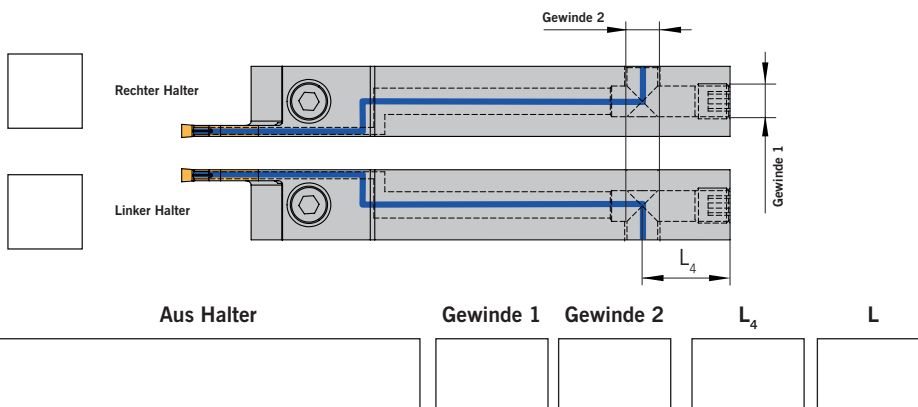

Hinweis bei Verwendung auf KMH-Werkzeughalter (VDI) Form C

Beim Einsatz der Halter in VDI-Aufnahmen Form C bitte die Gesamtlänge (L) nach folgender Maximallänge festlegen:

Bezeichnung	L
HSA 1616L-SA2403-32-ACS1-..	92,0
HSA 1616R-SA2403-32-ACS1-..	92,0
HSA 1616L-SA2403-44-ACS1-..	99,0
HSA 1616R-SA2403-44-ACS1-..	99,0
HSA 2020L-SA2403-32-ACS1-..	96,0
HSA 2020R-SA2403-32-ACS1-..	96,0
HSA 2020L-SA2403-44-ACS1-..	103,0
HSA 2020R-SA2403-44-ACS1-..	103,0
HSA 2020L-SA3503-52-ACS1-..	113,0
HSA 2020R-SA3503-52-ACS1-..	113,0
HSA 2020L-SA3503-65-ACS1-..	119,0
HSA 2020R-SA3503-65-ACS1-..	119,0
HSA 2525L-SA2403-44-ACS1-..	115,5
HSA 2525R-SA2403-44-ACS1-..	115,5
HSA 2525L-SA3503-52-ACS1-..	128,0
HSA 2525R-SA3503-52-ACS1-..	128,0
HSA 2525L-SA3503-65-ACS1-..	134,0
HSA 2525R-SA3503-65-ACS1-..	134,0

Download dieses Formulares unter: www.arno.de/service/downloads

Monoblock holder with through tool coolant access from the back



1

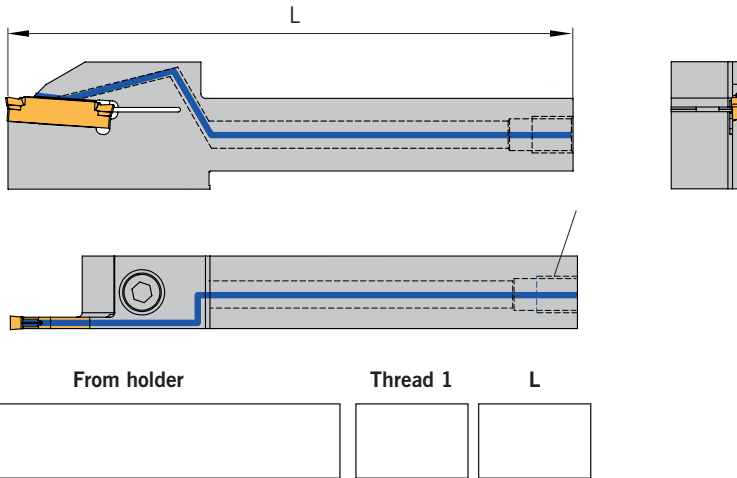

This tool we produce to the price of the standard tool.

Monoblock holder with through tool coolant access from the side

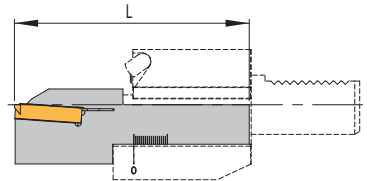

Remark by using the KMH holders (VDI) Form C

When using VDI holders Form C, please set overall length (L) by following maximum lengths:

Please select:

Design S. – Thread 2 is on the same side as the cutting edge

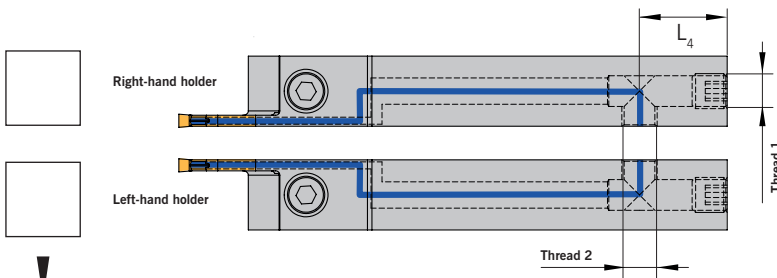

Design SG. – Thread 2 is on the opposite side of the cutting edge

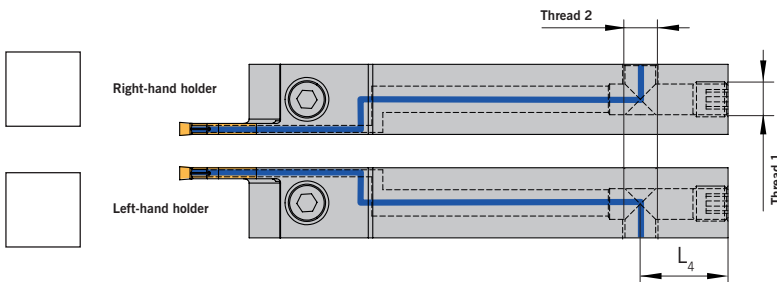

From holder Thread 1 Thread 2 L₄ L

--	--	--	--	--	--

Designation	L
HSA 1616L-SA2403-32-ACS1-..	92.0
HSA 1616R-SA2403-32-ACS1-..	92.0
HSA 1616L-SA2403-44-ACS1-..	99.0
HSA 1616R-SA2403-44-ACS1-..	99.0
HSA 2020L-SA2403-32-ACS1-..	96.0
HSA 2020R-SA2403-32-ACS1-..	96.0
HSA 2020L-SA2403-44-ACS1-..	103.0
HSA 2020R-SA2403-44-ACS1-..	103.0
HSA 2020L-SA3503-52-ACS1-..	113.0
HSA 2020R-SA3503-52-ACS1-..	113.0
HSA 2020L-SA3503-65-ACS1-..	119.0
HSA 2020R-SA3503-65-ACS1-..	119.0
HSA 2525L-SA2403-44-ACS1-..	115.5
HSA 2525R-SA2403-44-ACS1-..	115.5
HSA 2525L-SA3503-52-ACS1-..	128.0
HSA 2525R-SA3503-52-ACS1-..	128.0
HSA 2525L-SA3503-65-ACS1-..	134.0
HSA 2525R-SA3503-65-ACS1-..	134.0

Download this form from: www.arno.de/service/downloads

Utensile monoblocco con adduzione interna ACS1



1

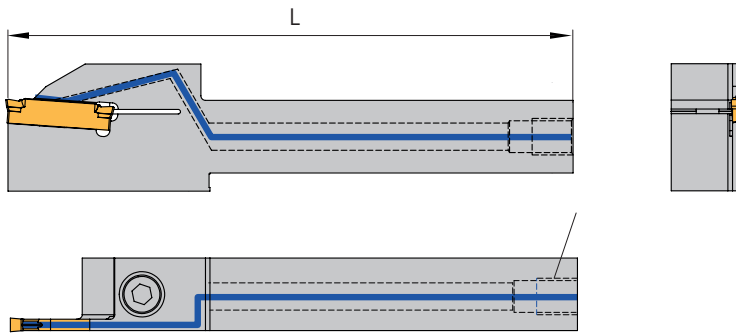

Ricavare da utensile

Filetto 1

L

--	--	--

Questi utensili vengono realizzati al prezzo dello standard.

Utensile monoblocco con adduzione interna ACS1 laterale

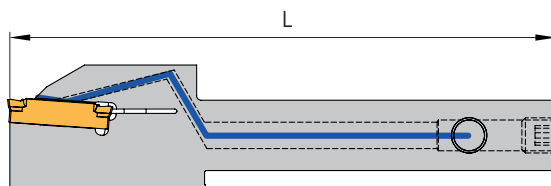

Prego indicare:

Versione S. – Filettatura 2 sul medesimo lato dell'inserto

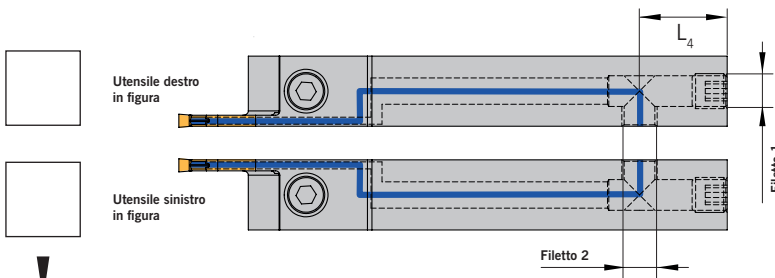

Versione SG. – Filettatura 2 sul lato opposto l'inserto

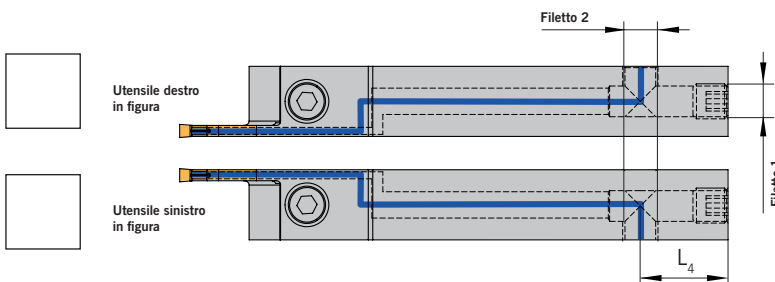

Ricavare da utensile

Filetto 1

Filetto 2

L₄

L

--	--	--	--	--

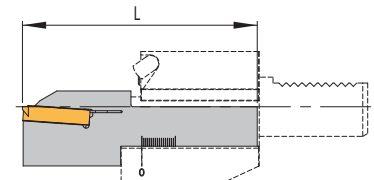

Nota sull'utilizzo adattatori KMH (VDI) Forma C

Con l'utilizzo di adattatori VDI forma C impostare la lunghezza totale (L) secondo la seguente tabella:

Articolo	L
HSA 1616L-SA2403-32-ACS1-..	92,0
HSA 1616R-SA2403-32-ACS1-..	92,0
HSA 1616L-SA2403-44-ACS1-..	99,0
HSA 1616R-SA2403-44-ACS1-..	99,0
HSA 2020L-SA2403-32-ACS1-..	96,0
HSA 2020R-SA2403-32-ACS1-..	96,0
HSA 2020L-SA2403-44-ACS1-..	103,0
HSA 2020R-SA2403-44-ACS1-..	103,0
HSA 2020L-SA3503-52-ACS1-..	113,0
HSA 2020R-SA3503-52-ACS1-..	113,0
HSA 2020L-SA3503-65-ACS1-..	119,0
HSA 2020R-SA3503-65-ACS1-..	119,0
HSA 2525L-SA2403-44-ACS1-..	115,5
HSA 2525R-SA2403-44-ACS1-..	115,5
HSA 2525L-SA3503-52-ACS1-..	128,0
HSA 2525R-SA3503-52-ACS1-..	128,0
HSA 2525L-SA3503-65-ACS1-..	134,0
HSA 2525R-SA3503-65-ACS1-..	134,0

Download del formula da: www.arno.de/service/downloads

HSA-UD-ACS2-S./S.G.

Monoblockhalter mit Innenkühlung ACS2 von der Seite – Spannung von oben und unten

Monoblock holder with through tool coolant (ACS2) access from the side - Locking from top and bottom

Utensile monoblocco con adduzione interna ACS2 laterale - Bloccaggio da sopra e sotto

1

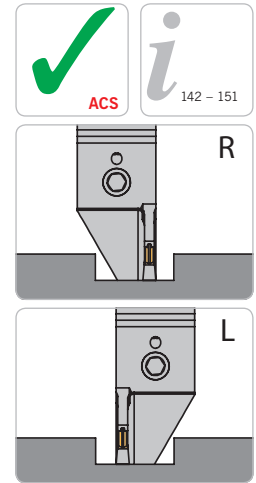
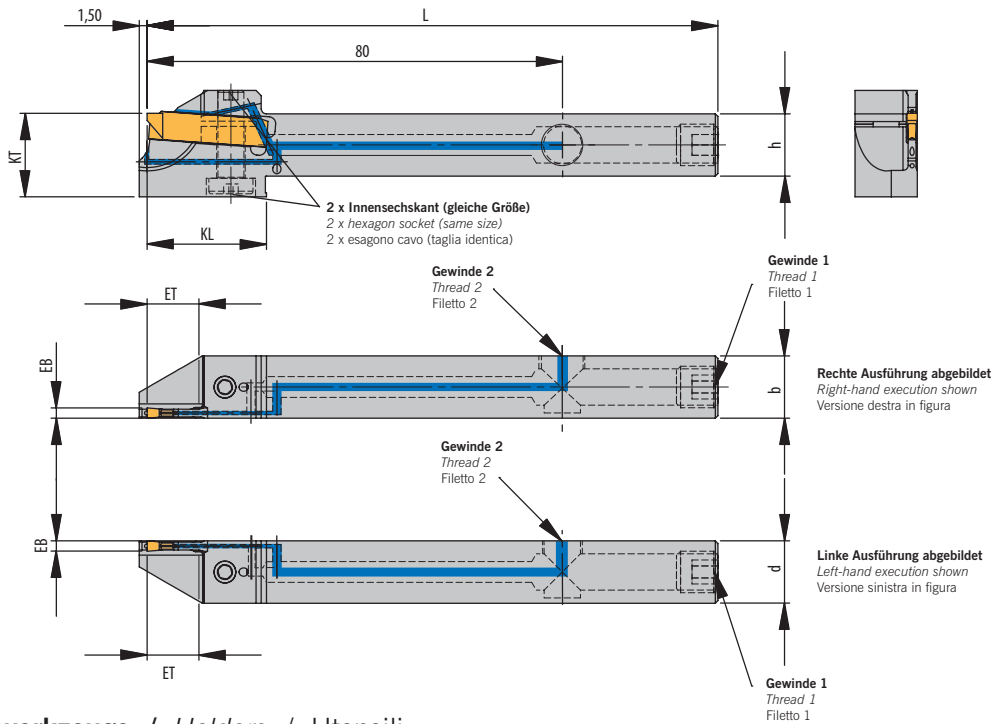

Trägerwerkzeuge / Holders / Utensili

Linke Ausführung, Kühlmittelanschluss auf der Seite der Schneide / Left hand execution, coolant access from the side of the cutting edge /
Esecuzione sinistra, adduzione laterale da lato inserto

Bezeichnung Designation Articolo	EB	ET	D _{max}	h	b	L	KL	KT	Gewinde 1 Thread 1 Filetto 1	Gewinde 2 Thread 2 Filetto 2	PG 37	Schneideinsatz Insert Inserto
HSA 1212UD-L-SA2402-20-ACS2-S1	2	10	20	12	12	110	23	16	M8x1	M8x1	●	SA 24-20...

D_{max} = Maximaler Durchmesser bei Vollmaterial
D_{max} = Maximum diameter in solid
D_{max} = Diametro massimo lavorazione dal pieno

Rechte Ausführung, Kühlmittelanschluss auf der gegenüberliegenden Seite der Schneide / Right hand execution, coolant access from the opposite side of the cutting edge /
Esecuzione destra, adduzione laterale dal lato opposto all'inserto

Bezeichnung Designation Articolo	EB	ET	D _{max}	h	b	L	KL	KT	Gewinde 1 Thread 1 Filetto 1	Gewinde 2 Thread 2 Filetto 2	PG 37	Schneideinsatz Insert Inserto
HSA 1212UD-R-SA2402-20-ACS2-S1G	2	10	20	12	12	110	23	16	M8x1	M8x1	●	SA 24-20...

D_{max} = Maximaler Durchmesser bei Vollmaterial
D_{max} = Maximum diameter in solid
D_{max} = Diametro massimo lavorazione dal pieno

Ersatzteile / Spare Parts / Ricambi

Trägerwerkzeug Holder Utensile	Schraube Screw Vite	Schlüssel Key Chiave
HSA 1212UD..	AS 0084	KP 3111

Kühlmittelanschlüsse finden Sie auf Seite 74
Coolant supply can be found on page 74
Raccordo vedere pagina 74

Holders for SA-Modules (MSA)
 Adattatore per moduli SA (MSA)

HSA...7... – mit ACS von hinten
HSA...7... – with ACS from the back
 HSA...7... – con ACS posteriore

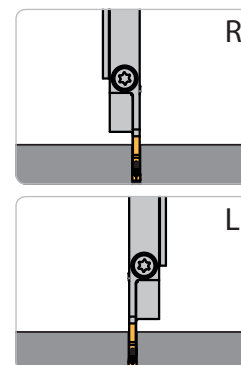
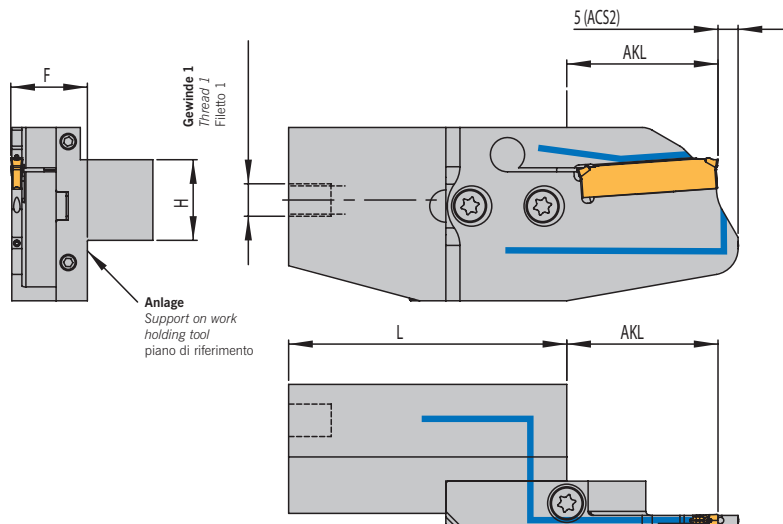

Linker Halter und linkes Modul montiert
 Left holder and left module shown
 Adattatore sinistra e modulo sinistra in figura

1

Halter für SA-Module (MSA) / Holders for SA-Modules (MSA) / Adattatore per moduli SA (MSA)

mit Innenkühlung ACS von hinten / with internal coolant (ACS) from the back / con adduzione interna (ACS) posteriore

Bezeichnung Designation Articolo	H	L	Gewinde 1 Thread 1 Filetto 1	PG 37
HSA-71629L-ACS-H1	16	54	M8 x 1	●
HSA-71629R-ACS-H1	16	54	M8 x 1	●
HSA-72032L-ACS-H1	20	69	M8 x 1	●
HSA-72032R-ACS-H1	20	69	M8 x 1	●
HSA-72536L-ACS-H1	25	84	M8 x 1	●
HSA-72536R-ACS-H1	25	84	M8 x 1	●
HSA-71629L-ACS-H2	16	54	G1/8"	●
HSA-71629R-ACS-H2	16	54	G1/8"	●
HSA-72032L-ACS-H2	20	69	G1/8"	●
HSA-72032R-ACS-H2	20	69	G1/8"	●
HSA-72536L-ACS-H2	25	84	G1/8"	●
HSA-72536R-ACS-H2	25	84	G1/8"	●
HSA-71629L-ACS-H3	16	54	G1/4"	●
HSA-71629R-ACS-H3	16	54	G1/4"	●
HSA-72032L-ACS-H3	20	69	G1/4"	●
HSA-72032R-ACS-H3	20	69	G1/4"	●
HSA-72536L-ACS-H3	25	84	G1/4"	●
HSA-72536R-ACS-H3	25	84	G1/4"	●

Modul Designation Articolo	AKL	F
MSA-...-32-ACS	22,0	19,0
MSA-...-44-ACS	27,0	
MSA-...-52-ACS	37,5	
MSA-...-65-ACS	37,5	
MSA-...-69-ACS	39,5	
MSA-...-80-ACS	45,0	
MSA-...-90-ACS	50,0	
MSA-...-105-ACS	58,0	

Hinweis: Halter HSA...7... werden mit Schraube und Schlüssel geliefert, jedoch ohne Modul.

Remark: Holders HSA-7... are supplied with screw and key, but without modules.

Nota: Adattatori HSA-7 sono forniti con viti e chiave, ma senza modulo.

Passende Module finden Sie ab Seiten 122.

KMH-Werkzeughalter (VDI) finden Sie auf den Seiten 458 bis 477.

Suitable modules can be found starting on page 122.

KMH holders (VDI) can be found on pages 458 to 477.

Per moduli compatibili vedere de pagina 122 e 128.

Adattatori KMH (VDI) vedere pagine 458 a 477.

Kühlmittelanschlüsse finden Sie auf Seite 74

Coolant supply can be found on page 74

Raccordo vedere pagina 74



Diese Monoblockhalter bekommen Sie mit Ihren spezifischen Kühlan schlüssen. Ein Anfrageblatt hierzu finden Sie auf Seite 80 oder im Internet unter: www.arno.de/service/downloads

The coolant inlet can be supplied to your specification, please complete enquiry sheet on page 80 or download this from: www.arno.de/service/downloads

Questi corpi utensile sono fornibili con specifiche connessioni del refrigerante, Vedere modulo richiesta a Pag. 80 o download del modulo da: www.arno.de/service/downloads

Halter HSA...7...ACS mit Innenkühlung ACS von hinten



1

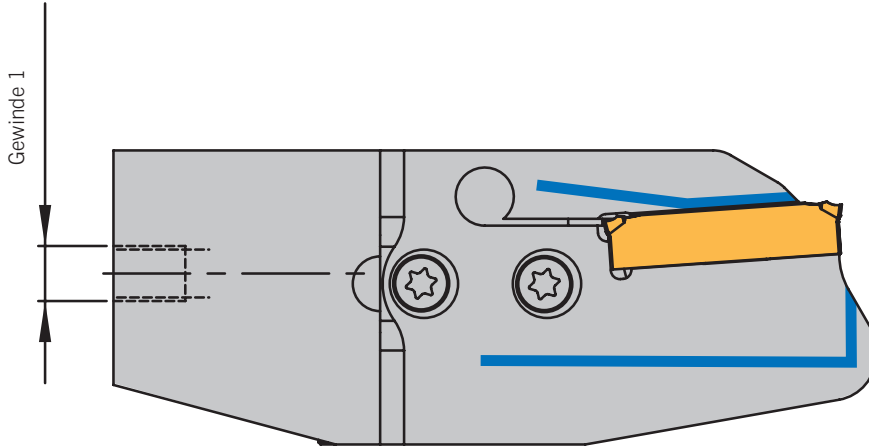

Diese Halter fertigen wir Ihnen zum Preis des Standardwerkzeuges.

Aus Halter

Gewinde 1



Download dieses Formulares unter: www.arno.de/service/downloads

Holder HSA-7 with internal coolant ACS from the back



1

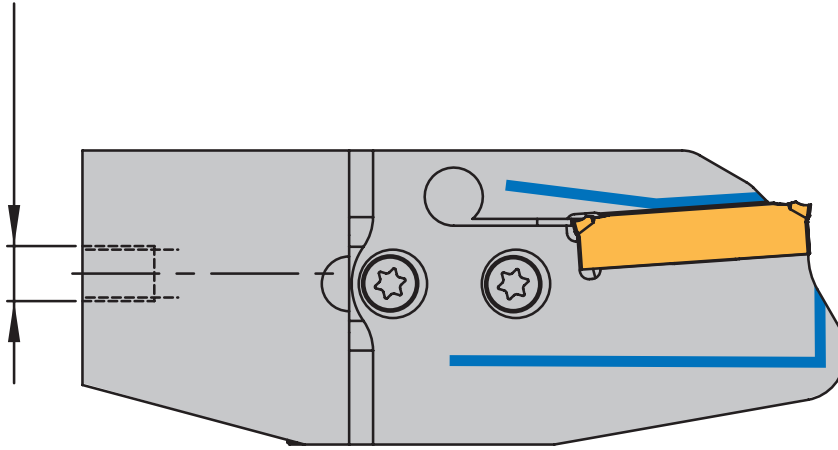

This tool we produce to the price of the standard tool.

From holder

Thread 1

Download this form from: www.arno.de/service/downloads

Adattatore HSA...7... per moduli MSA con refrigerazione interna posteriore

ARNO® SpecialDesign

1

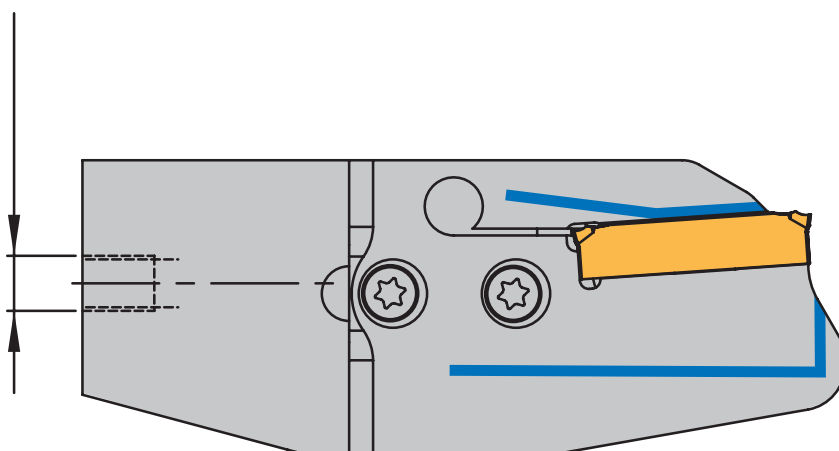

La modificazione del filetto posteriore per il attacco ACS del adattatore HSA ...7... é incluso nel prezzo standard

Ricavare da utensile

Filetto 1

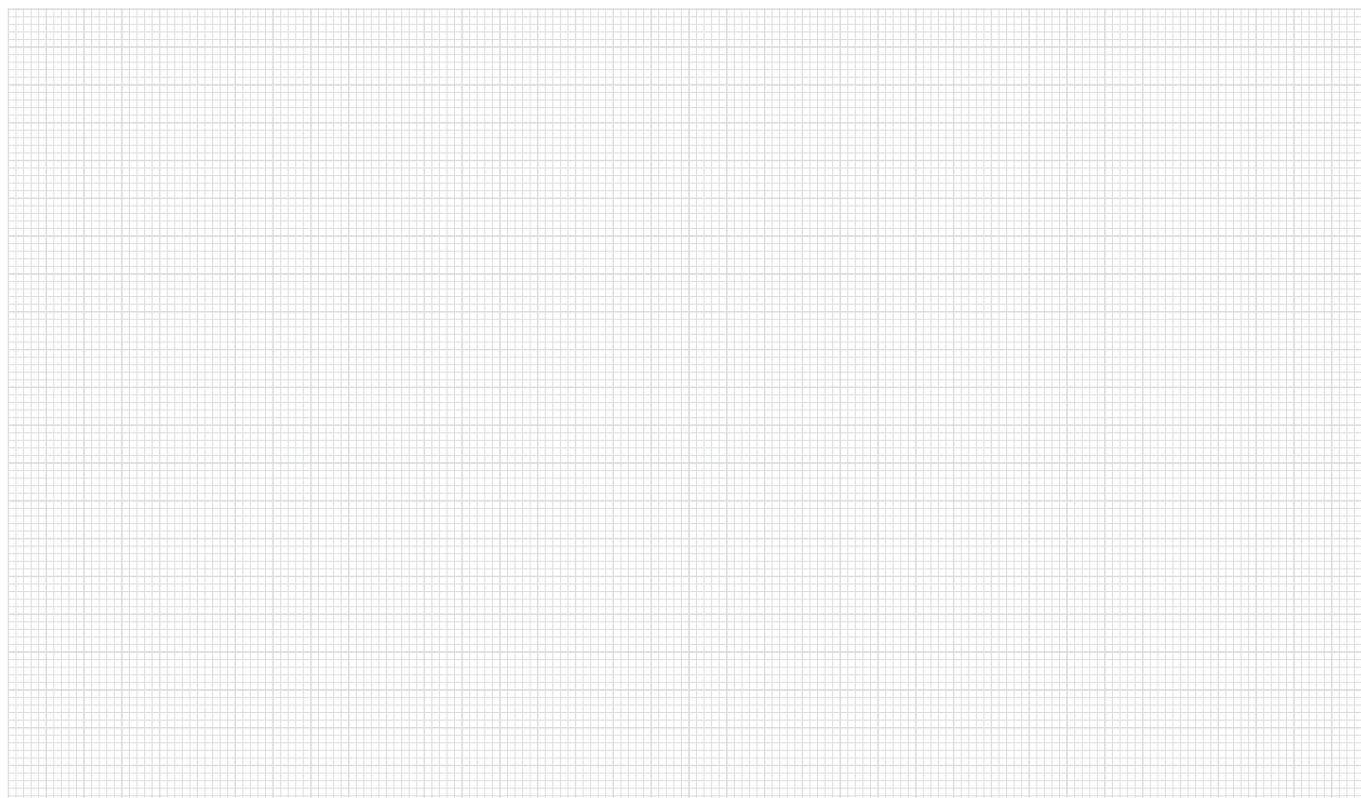

Download del formula da: www.arno.de/service/downloads

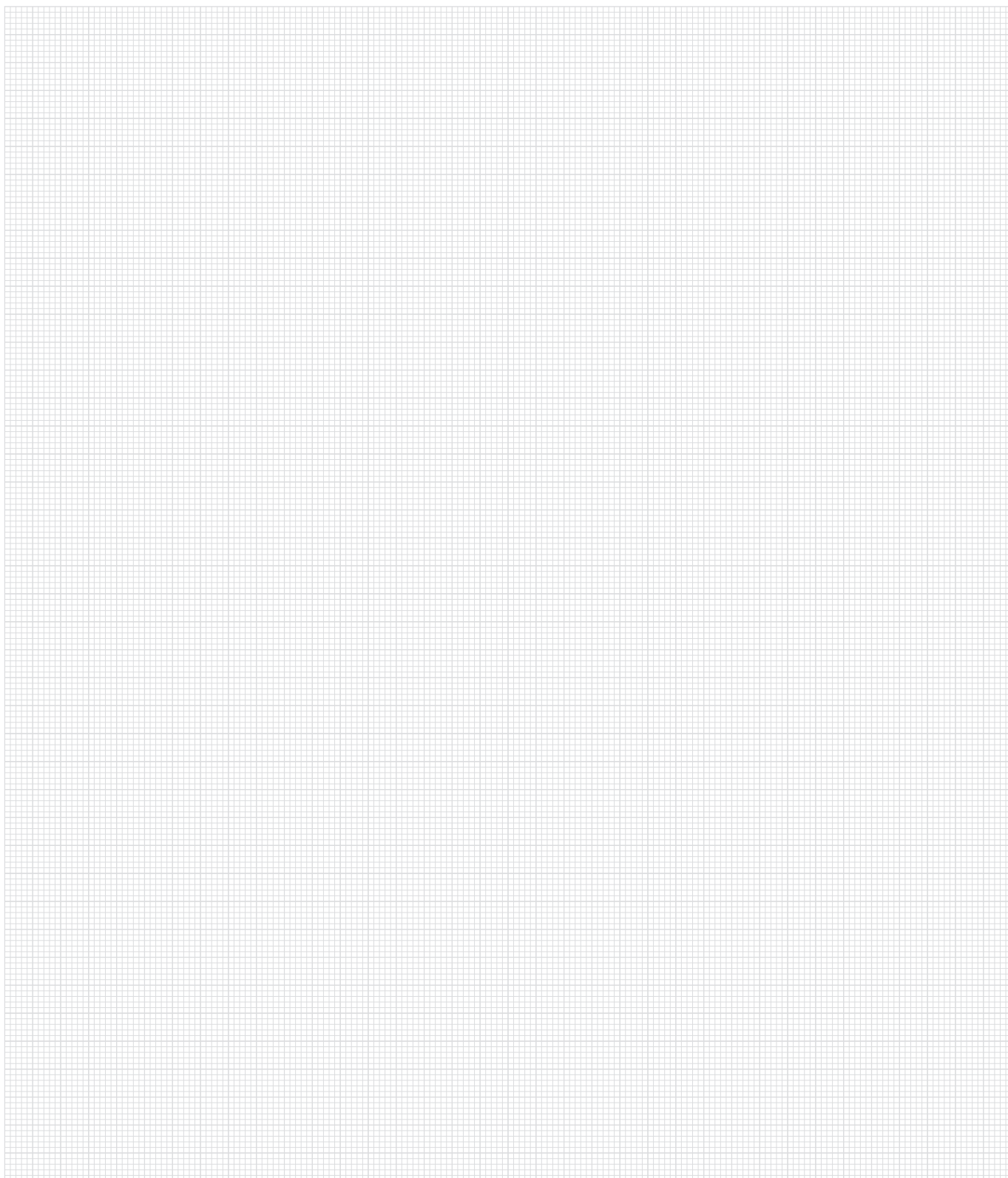

Weitere Informationen finden Sie unter:

For more information see:

Per maggiori informazioni visita il sito:

www.arno.de

1



KMH-Werkzeugaufnahmen für Monoblockhalter ACS1-UN

KMH holder for monoblock holders ACS1-UN

Adattatore KMH per utensili monoblocco ACS1-UN

VDI 25, 30, 40 – **Form B** / *Form B* / *Forma B*

Seite/Page/Pagina **86**



KMH-Werkzeugaufnahmen für Monoblockhalter ACS1-UN

KMH holder for monoblock holders ACS1-UN

Adattatore KMH per utensili monoblocco ACS1-UN

VDI 25, 30, 40 – **Form C** / *Form C* / *Forma C*

Seite/Page/Pagina **88**

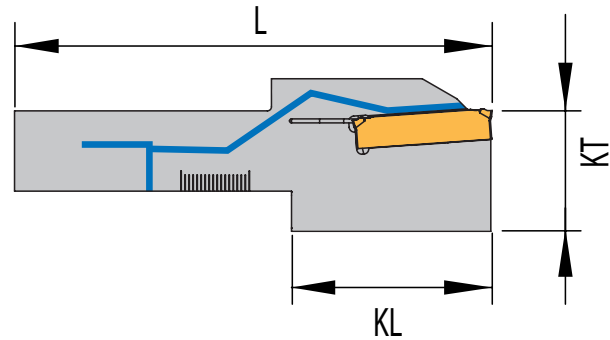

Monoblockhalter -UN

Monoblock holder -UN

Utensile monoblocco -UN

Mit Innenkühlung ACS1 von unten (Nut) 16 x 16, 20 x 20, 25 x 25

With through tool coolant ACS1 from the bottom (notch) 16 x 16, 20 x 20, 25 x 25

Con refrigerante interno ACS1 da sotto (asola) 16 x 16, 20 x 20, 25 x 25



KMH-Werkzeugaufnahmen für Halter HSA...7...

KMH holder for holder HSA...7...

Adattatore KMH per utensili monoblocco HSA...7...

VDI 25, 30, 40 – **Form B** / *Form B* / *Forma B*

SA-Module auf HSA-7-ACS-UN Mit Innenkühlung ACS2 von unten (Nut)

SA-module on HAS-7-ACS-UN with through tool coolant ACS2 from the bottom (notch)

Modulo SA su HSA-7-ACS-UN con refrigerante interno ACS2 da sotto (asola)

Seite/Page/Pagina **90**

1



KMH-Werkzeugaufnahmen für Halter HSA...7...

KMH holder for holder HSA...7...

Adattatore KMH per utensili monoblocco HSA...7...

VDI 25, 30, 40 – **Form C** / *Form C* / *Forma C*

SA-Module auf HSA-7-ACS-UN mit Innenkühlung ACS2 von unten (Nut)

SA-module on HAS-7-ACS-UN with through tool coolant ACS2 from the bottom (notch)

Modulo SA su HSA-7-ACS-UN con refrigerante interno ACS2 da sotto (asola)

Seite/Page/Pagina **92**

Halter HSA...7...ACS

Folder HSA...7...ACS

Adattatore HSA...7...ACS

– mit Innenkühlung ACS von hinten / – mit Innenkühlung ACS von unten (Nut)

– with internal coolant ACS from the back / – with internal coolant ACS from the bottom (notch)

– con adduzione interna (ACS) posteriore / – con adduzione interna (ACS) da sotto (asola)

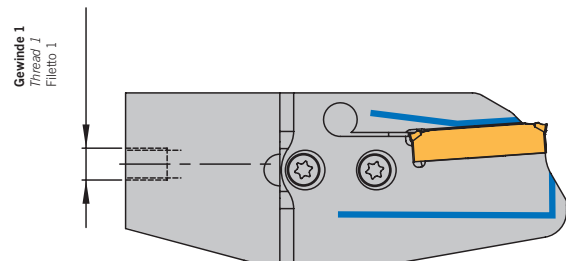

Seite/Page/Pagina **79**

Monoblock holders with KMH holder (VDI)
Adattatore KMH (VDI) per utensili monoblocco

HSA-ACS1-UN auf KMH01 – Form B HSA-ACS1-UN with KMH01 – Form B HSA-ACS1-UN con adattatore KMH01 – Forma B

1

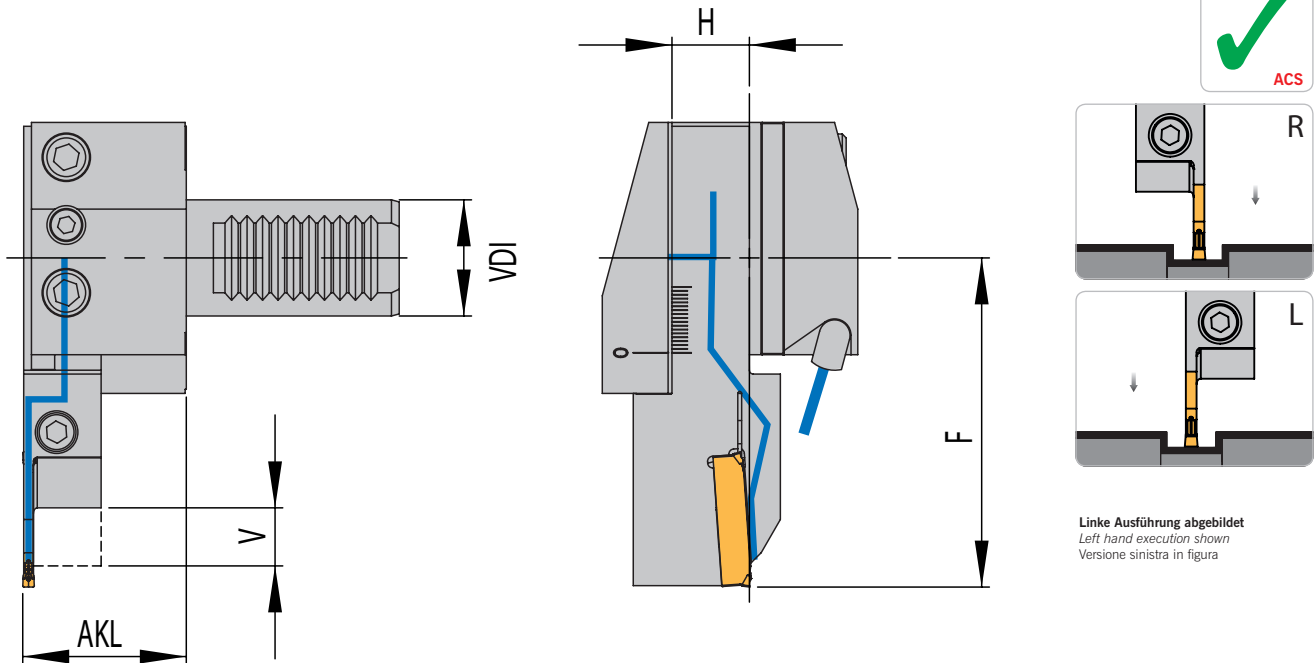

Handling: In Tabelle 1 den benötigten KMH-Werkzeughalter (VDI) und den Halter-Typ auswählen. Entsprechend dem Halter-Typ den benötigten Monoblockhalter und die Schneidplatte mit Tabelle 2 bestimmen.

HANDLING: Please select the KMH holder (VDI) and holder type from table 1. According to holder type please select suitable monoblock holder and insert from table 2.

GUIDA ALLA LETTURA: Scegliere l'adattatore KMH (VDI) e tipologia di forma dalla tabella 1. Dalla tabella 2 scegliere il relativo utensile ed inserto.

KMH-Werkzeugaufnahme / KMH holder / Adattatore KMH

Form B für HSA...ACS1-UN / Form B for HSA...ACS1-UN / Forma B per HSA...ACS1-UN

	Form Form Forma	VDI	H _{Schaft} Stelo	AKL	V*	KMH-Werkzeugaufnahme (VDI)	PG 47	Monoblockhalter
						KMH holder (VDI) Adattatore KMH (VDI)		Monoblock holder Utensili monoblocco
Tabelle 1 / Table 1 / Tabella 1	B1	25	16	32,3	15	KMH01-B1-25x16x30-IK	●	HSA 1616 L ...
		30	20	42,3	17	KMH01-B1-30x20x40-IK	●	HSA 2020 L ...
		40	25	47,3	22	KMH01-B1-40x25x44-IK	●	HSA 2525 L ...
	B2	25	16	32,3	15	KMH01-B2-25x16x30-IK	●	HSA 1616 R ...
		30	20	42,3	17	KMH01-B2-30x20x40-IK	●	HSA 2020 R ...
		40	25	47,3	22	KMH01-B2-40x25x44-IK	●	HSA 2525 R ...
	B3	25	16	32,3	15	KMH01-B3-25x16x30-IK	●	HSA 1616 R ...
		30	20	42,3	17	KMH01-B3-30x20x40-IK	●	HSA 2020 R ...
		40	25	47,3	22	KMH01-B3-40x25x44-IK	●	HSA 2525 R ...
	B4	25	16	32,3	15	KMH01-B4-25x16x30-IK	●	HSA 1616 L ...
		30	20	42,3	17	KMH01-B4-30x20x40-IK	●	HSA 2020 L ...
		40	25	47,3	22	KMH01-B4-40x25x44-IK	●	HSA 2525 L ...

* Der Halter kann um den Wert „V“ in der VDI-Aufnahme nach vorne geschoben werden.

* The tool holder can be extended by dimension „V“ in the VDI holder.

* L'utensile può essere estratto dal portautensile del valore „V“ massimo.

Ersatzteile wie Kühlmitteldüse und Schraube für Kühlmitteldüse finden Sie auf Seite 458 – 468

Spare parts like coolant jet and screw for coolant jet can be found on page 458 – 468

Ricambi come ugello refrigerante e vite per ugello refrigerante vedere pagina 458 – 468

Monoblock holders with KMH holder (VDI)
Adattatore KMH (VDI) per utensili monoblocco

HSA... -ACS1-UN.. für KMH-Werkzeugaufnahmen (VDI) / HSA... -ACS1-UN.. for KMH holder (VDI) / HSA...-ACS1-UN.. per adattatori KMH (VDI)

Monoblockhalter mit Innenkühlung ACS1 von unten (Nutm) / Monoblock holder with coolant supply from the bottom (Notch) / Utensili monoblocco con refrigerazione interna ACS1 da sotto (Asola)

	Monoblockhalter Monoblock holder Tipo utensile	D _{max}	EB	ET	Bezeichnung Designation Articolo	F	D _R	PG 37	H	Schneideinsatz Insert Inserto
Tabelle 2 / Table 2 / Tabella 2	HSA 1616 L ...	32	3	16	HSA 1616L-SA2403-32-ACS1-UN	68	-	●	16	SA 24-30...
		44	3	22	HSA 1616L-SA2403-44-ACS1-UN	75	61	●		
	HSA 1616 R ...	32	3	16	HSA 1616R-SA2403-32-ACS1-UN	68	-	●	16	SA 24-30...
		44	3	22	HSA 1616R-SA2403-44-ACS1-UN	75	61	●		
	HSA 2020 L ...	32	3	16	HSA 2020L-SA2403-32-ACS1-UN	62	-	●	20	SA 24-30...
		44	3	22	HSA 2020L-SA2403-44-ACS1-UN	68,5	61	●		
		52	3	26	HSA 2020L-SA3503-52-ACS1-UN	79	68	●		
	HSA 2020 R ...	32	3	16	HSA 2020R-SA2403-32-ACS1-UN	62	-	●	20	SA 24-30...
		44	3	22	HSA 2020R-SA2403-44-ACS1-UN	68,5	61	●		
		52	3	26	HSA 2020R-SA3503-52-ACS1-UN	79	68	●		
	HSA 2525 L ...	44	3	22	HSA 2525L-SA2403-44-ACS1-UN	74	61	●	25	SA 24-30...
		52	3	26	HSA 2525L-SA3503-52-ACS1-UN	86,5	68	●		
		65	3	32,5	HSA 2525L-SA3503-65-ACS1-UN	92,5	80	●		
	HSA 2525 R ...	44	3	22	HSA 2525R-SA2403-44-ACS1-UN	74	61	●	25	SA 24-30...
		52	3	26	HSA 2525R-SA3503-52-ACS1-UN	86,5	68	●		
		65	3	32,5	HSA 2525R-SA3503-65-ACS1-UN	92,5	80	●		

Die Kühlmittelversorgung ist innerhalb des Verstellwegs sichergestellt. Das „AKL“-Maß ändert sich entsprechend.
The coolant supply is guaranteed within the adjustment range. Dimension "AKL" changes accordingly.
L'alimentazione del refrigerante è assicurato all'interno del campo di registrazione. La dimensione "AKL" cambia di conseguenza.

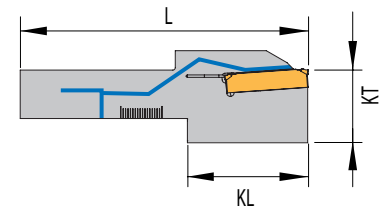

Ersatzteile / Spare Parts / Ricambi

Trägerwerkzeug Holder Utensile	Schraube Screw Vite	Schlüssel Key Chiave
HSA 1616... - HSA 2525...-SA24...-ACS1...	DIN912 M5x16-12.9	KP 1321
HSA 2020... - HSA 2525...-SA35...-52-ACS1...	DIN912 M6x20-12.9	KP 5421
HSA 2020... - HSA 2525...-SA35...-65-ACS1...	DIN912 M6x20-12.9	KP 5421

Einbaumöglichkeiten / Assembly options / Combinazioni di montaggio

Halter KMH01-B ... mit linkem Monoblockhalter Holder KMH01-B ... with left-hand monoblock holder Adattatore KMH01-B ... con utensile monoblocco sinistro		Halter KMH01-B ... mit rechtem Monoblockhalter Holder KMH01-B ... with right-hand monoblock holder Adattatore KMH01-B ... con utensile monoblocco destro	
KMH01-B1 ...	KMH01-B4 ...	KMH01-B2 ...	KMH01-B3 ...
Einbaulage normal Normal assembly Montaggio normale	Einbaulage Überkopf Upside down assembly Montaggio invertito	Einbaulage normal Normal assembly Montaggio normale	Einbaulage Überkopf Upside down assembly Montaggio invertito

Monoblock holders with KMH holder (VDI)
Adattatore KMH (VDI) per utensili monoblocco

HSA-ACS1-UN auf KMH01 – Form C HSA-ACS1-UN with KMH01 – Form C HSA-ACS1-UN con adattatore KMH01 – Forma C

1

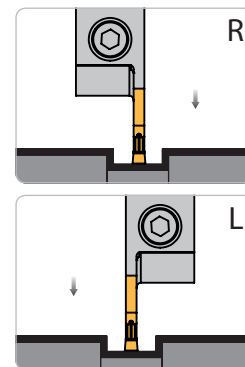

Linke Ausführung abgebildet
Left-hand execution shown
Versione sinistra in figura

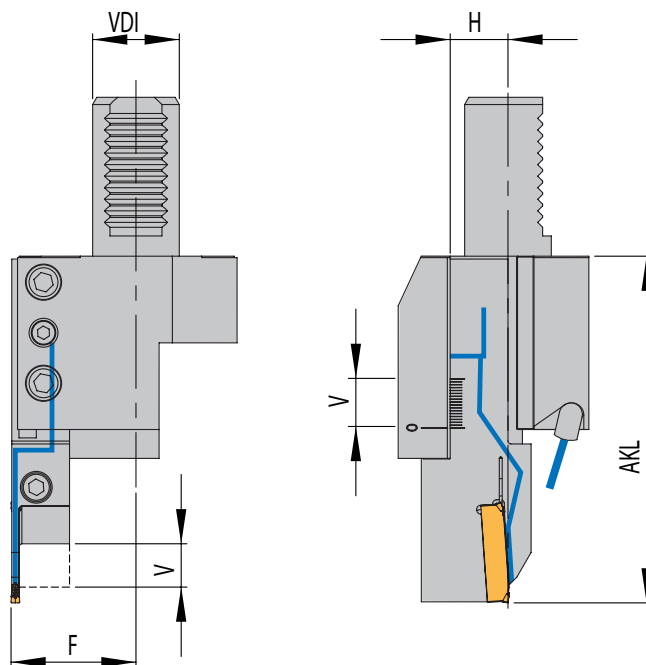

N NEU/NEW/NUOVO

Handling: In Tabelle 1 den benötigten KMH-Werkzeughalter (VDI) und den Halter-Typ auswählen. Entsprechend dem Halter-Typ den benötigten Monoblockhalter und die Schneidplatte mit Tabelle 2 bestimmen.
HANDLING: Please select the KMH holder (VDI) and holder type from table 1. According to holder type please select suitable monoblock holder and insert from table 2.
GUIDA ALLA LETTURA: Scegliere l'adattatore KMH (VDI) e tipologia di forma dalla tabella 1. Dalla tabella 2 scegliere il relativo utensile ed inserto.

KMH-Werkzeugaufnahme / KMH holder / Adattatore KMH

Form C für HSA...ACS1-UN / Form C for HSA...ACS1-UN / Forma C per HSA...ACS1-UN

Form Form Forma	VDI	H _{Schaft Stelo}	AKL	V*	KMH-Werkzeugaufnahme (VDI) KMH holder (VDI) Adattatore KMH (VDI)	PG 47	Monoblockhalter Monoblock holder Utensili monoblocco
C1	25	16	35,3	15	KMH01-C1-25x16x55-IK	●	HSA 1616 R
	30	20	37,3	17	KMH01-C1-30x20x70-IK	●	HSA 2020 R
	40	25	46,3	22	KMH01-C1-40x25x85-IK	●	HSA 2525 R
C2	25	16	35,3	15	KMH01-C2-25x16x55-IK	●	HSA 1616 L
	30	20	37,3	17	KMH01-C2-30x20x70-IK	●	HSA 2020 L
	40	25	46,3	22	KMH01-C2-40x25x85-IK	●	HSA 2525 L
C3	25	16	35,3	15	KMH01-C3-25x16x55-IK	●	HSA 1616 L
	30	20	37,3	17	KMH01-C3-30x20x70-IK	●	HSA 2020 L
	40	25	46,3	22	KMH01-C3-40x25x85-IK	●	HSA 2525 L
C4	25	16	35,3	15	KMH01-C4-25x16x55-IK	●	HSA 1616 R
	25	20	39,3	17	KMH01-C4-25x20x70-IK	●	HSA 2020 R
	30	20	37,3	17	KMH01-C4-30x20x70-IK	●	HSA 2020 R
	40	25	46,3	22	KMH01-C4-40x25x85-IK	●	HSA 2525 R

* Der Halter kann um den Wert „V“ in der VDI-Aufnahme nach vorne geschoben werden.
* The tool holder can be extended by dimension „V“ in the VDI holder.
* L'utensile può essere estratto dal portautensile del valore „V“ massimo.

Ersatzteile wie Kühlmitteldüse und Schraube für Kühlmitteldüse finden Sie auf Seite 470 – 477
Spare parts like coolant jet and screw for coolant jet can be found on page 470 – 477
Ricambi come ugello refrigerante e vite per ugello refrigerante vedere pagina 470 – 477

Monoblock holders with KMH holder (VDI)
Adattatore KMH (VDI) per utensili monoblocco

HSA...-ACS1-UN.. für KMH-Werkzeugaufnahmen (VDI) / HSA...-ACS1-UN.. for KMH holder (VDI) / HSA...-ACS1-UN..per adattatori KMH (VDI)

Monoblockhalter mit Innenkühlung ACS1 von unten (Nutm) / Monoblock holder with coolant supply from the bottom (Notch) / Utensili monoblocco con refrigerazione interna ACS1 da sotto (Asola)

	Monoblockhalter Monoblock holder Tipo utensile	D _{max}	EB	ET	Bezeichnung Designation Articolo	AKL	D _R	PG 37	H	Schneideinsatz Insert Inserto
	Tabelle 2 / Table 2 / Tabella 2	HSA 1616 L ...	32	3	16	HSA 1616L-SA2403-32-ACS1-UN	93,0	–	●	16
44			3	22	HSA 1616L-SA2403-44-ACS1-UN	100,0	61	●		
HSA 1616 R ...		32	3	16	HSA 1616R-SA2403-32-ACS1-UN	93,0	–	●	16	SA 24-30...
		44	3	22	HSA 1616R-SA2403-44-ACS1-UN	100,0	61	●		
HSA 2020 L ...		32	3	16	HSA 2020L-SA2403-32-ACS1-UN	97,0	–	●	20	SA 24-30...
		44	3	22	HSA 2020L-SA2403-44-ACS1-UN	104,0	61	●		
		52	3	26	HSA 2020L-SA3503-52-ACS1-UN	114,0	68	●		
HSA 2020 R ...		32	3	16	HSA 2020R-SA2403-32-ACS1-UN	97,0	–	●	20	SA 24-30...
		44	3	22	HSA 2020R-SA2403-44-ACS1-UN	104,0	61	●		
		52	3	26	HSA 2020R-SA3503-52-ACS1-UN	114,0	68	●		
HSA 2525 L ...		44	3	22	HSA 2525L-SA2403-44-ACS1-UN	116,5	61	●	25	SA 24-30...
		52	3	26	HSA 2525L-SA3503-52-ACS1-UN	129,0	68	●		
		65	3	32,5	HSA 2525L-SA3503-65-ACS1-UN	135,0	80	●		
HSA 2525 R ...		44	3	22	HSA 2525R-SA2403-44-ACS1-UN	116,5	61	●	25	SA 24-30...
		52	3	26	HSA 2525R-SA3503-52-ACS1-UN	129,0	68	●		
		65	3	32,5	HSA 2525R-SA3503-65-ACS1-UN	135,0	80	●		

Die Kühlmittelversorgung ist innerhalb des Verstellwegs sichergestellt. Das „AKL“-Maß ändert sich entsprechend.
The coolant supply is guaranteed within the adjustment range. Dimension "AKL" changes accordingly.
L'alimentazione del refrigerante è assicurata all'interno del campo di registrazione. La dimensione "AKL" cambia di conseguenza.

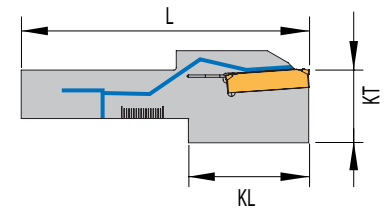

Ersatzteile / Spare Parts / Ricambi

Trägerwerkzeug Holder Utensile	Schraube Screw Vite	Schlüssel Key Chiave
HSA 1616... - HSA 2525...-SA24...-ACS1...	DIN912 M5x16-12.9	KP 1321
HSA 2020... - HSA 2525...-SA35...-52-ACS1...	DIN912 M6x20-12.9	KP 5421
HSA 2020... - HSA 2525...-SA35...-65-ACS1...	DIN912 M6x20-12.9	KP 5421

Einbaumöglichkeiten / Assembly options / Combinazioni di montaggio

Halter KMH01-C ... mit linkem Monoblockhalter Holder KMH01-C ... with left-hand monoblock holder Adattatore KMH01-C ... con utensile monoblocco sinistro		Halter KMH01-C ... mit rechtem Monoblockhalter Holder KMH01-C ... with right-hand monoblock holder Adattatore KMH01-C ... con utensile monoblocco destro	
KMH01-C2 ...	KMH01-C3 ...	KMH01-C1 ...	KMH01-C4 ...
Einbaulage normal Normal assembly Montaggio normale	Einbaulage Überkopf Upside down assembly Montaggio invertito	Einbaulage normal Normal assembly Montaggio normale	Einbaulage Überkopf Upside down assembly Montaggio invertito

Holder for SA-Modules HSA-7... for KMH holder (VDI)

Adattatori per moduli SA con adattatore KMH (VDI)

HSA...7...ACS-UN auf KMH01 – Form B

HSA...7...ACS-UN with KMH01 – Form B

HSA...7...ACS-UN con adattatore KMH01 – Forma B

1

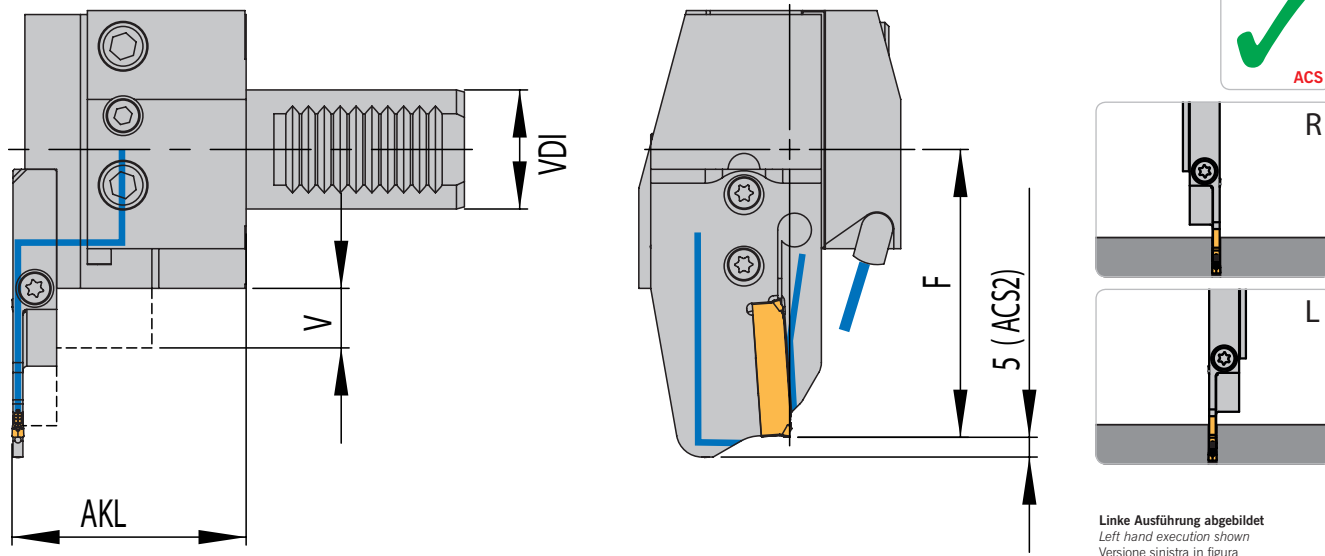

Handling:

In Tabelle 1 den gewünschten KMH-Werkzeughalter (VDI) und den passenden Halter auswählen. Anhand Tabelle 2 dann – entsprechend dem Modul-Typ – das passende Modul (ab Seite 122) und den Schneideinsatz (ab Seite 132) bestimmen.

HANDLING:

Please select the KMH holder (VDI) and suitable holder from table 1. According to module type, please find suitable modules (starting page 122) and insert (starting page 132) from table 2.

GUIDA ALLA LETTURA:

Scegliere l'adattatore KMH (VDI) e tipologia di adattatore tabella 1. Dalla tabella 2 scegliere il relativo modulo (da pagina 122 in poi) ed inserto (da pagina 132 in poi).

KMH-Werkzeugaufnahme / KMH holder / Adattatore KMH

Form B für HSA-7-ACS-UN / Form B for HSA-7-ACS-UN / Forma B per HSA-7-ACS-UN

Form Form Forma	VDI	H _{Schaft} Shank Stelo	AKL	V*	KMH-Werkzeugaufnahme (VDI) KMH holder (VDI) Adattatore KMH (VDI)	PG 47	Halter SA-Module Holder SA-Module Adattatore per modulo SA	PG 37	Modul-Typ Module type Tipo Modulo
B1	25	16	49,0	15	KMH01-B1-25x16x55-IK	●	HSA 71629L-ACS-UN	●	MSA-SL-..
	30	20	59,0	17	KMH01-B1-30x20x70-IK	●	HSA 72032L-ACS-UN	●	
	40	25	63,0	22	KMH01-B1-40x25x85-IK	●	HSA 72536L-ACS-UN	●	
B2	25	16	49,0	15	KMH01-B2-25x16x55-IK	●	HSA 71629R-ACS-UN	●	MSA-SR-..
	30	20	59,0	17	KMH01-B2-30x20x70-IK	●	HSA 72032R-ACS-UN	●	
	40	25	63,0	22	KMH01-B2-40x25x85-IK	●	HSA 72536R-ACS-UN	●	
B3	25	16	49,0	15	KMH01-B3-25x16x55-IK	●	HSA 71629R-ACS-UN	●	MSA-SR-..
	30	20	59,0	17	KMH01-B3-30x20x70-IK	●	HSA 72032R-ACS-UN	●	
	40	25	63,0	22	KMH01-B3-40x25x85-IK	●	HSA 72536R-ACS-UN	●	
B4	25	16	49,0	15	KMH01-B4-25x16x55-IK	●	HSA 71629L-ACS-UN	●	MSA-SL-..
	30	20	59,0	17	KMH01-B4-30x20x70-IK	●	HSA 72032L-ACS-UN	●	
	40	25	63,0	22	KMH01-B4-40x25x85-IK	●	HSA 72536L-ACS-UN	●	

* Der Halter kann um den Wert „V“ in der VDI-Aufnahme nach vorne geschoben werden.

Die Kühlmittelversorgung ist innerhalb des Verstellwegs durch eine mechanische Begrenzung sichergestellt. Das „AKL“-Maß ändert sich entsprechend.

Hinweis: Halter HSA...7... werden ohne Module geliefert.

* The tool holder can be extended by dimension „V“ in the VDI holder.

The coolant supply is guaranteed within the adjustment range by a mechanical limitation. Dimension „F“ changes accordingly.

Remark: Holders HSA-7... are supplied without modules.

* L'utensile può essere estratto dal portautensile del valore „V“ massimo.

L'adduzione del refrigerante è garantita tramite un fermo. Dimensione „F“ cambia in relazione.

Nota: Adattatori HSA-7 sono forniti senza modulo.

Ersatzteile wie Kühlmitteldüse und Schraube für Kühlmitteldüse finden Sie auf Seite 458 – 468

Spare parts like coolant jet and screw for coolant jet can be found on page 458 – 468

Ricambi come ugello refrigerante e vite per ugello refrigerante vedere pagina 458 – 468

Holder for SA-Modules HSA-7... for KMH holder (VDI)
 Adattatori per moduli SA con adattatore KMH (VDI)

Modul MSA-... / Module MSA-... / Modulo MSA-...

	Modul-Typ Module type Tipo Modulo	F _{VDI25}	F _{VDI30}	F _{VDI40}
Tabelle 2 / Table 2 / Tabella 2	MSA-...-32-ACS	52,0	57,0	64,5
	MSA-...-44-ACS	57,0	62,0	69,5
	MSA-...-52-ACS	67,5	72,5	80,0
	MSA-...-65-ACS	67,5	72,5	80,0
	MSA-...-69-ACS	69,5	74,5	82,0
	MSA-...-80-ACS	75,0	80,0	87,5
	MSA-...-90-ACS	80,0	85,0	92,5
	MSA-...-105-ACS	88,0	93,0	100,5

1

Einbaumöglichkeiten / Assembly options / Combinazioni di montaggio

Halter KMH01-B ... mit linkem Monoblockhalter und linkem Modul <i>Holder KMH01-B ...</i> <i>with left-hand Monoblockholder and left module</i> Adattatore KMH01-B ... con utensile monoblocco sinistro e modulo sinistro		Halter KMH01-B ... mit rechtem Monoblockhalter und rechtem Modul <i>Holder KMH01-B ...</i> <i>with right-hand Monoblockholder and right module</i> Adattatore KMH01-B ... con utensile monoblocco destro e modulo destro	
KMH01-B1 ...	KMH01-B4 ...	KMH01-B2 ...	KMH01-B3 ...
Einbaulage normal <i>Normal assembly</i> Montaggio normale	Einbaulage Überkopf <i>Upside down assembly</i> Montaggio invertito	Einbaulage normal <i>Normal assembly</i> Montaggio normale	Einbaulage Überkopf <i>Upside down assembly</i> Montaggio invertito

Zusätzliche Kühlung / Additional coolant / Ugello refrigerante prolungato

Ist eine zusätzliche Kühlung durch die externe Kühlmitteldüse erwünscht, bitte folgende Kühlmitteldüse verwenden:

If additional coolant is needed from external coolant jet, please use following part number:

In caso di assemblaggio con adattatori portamodulo sostituire l'ugello standard con quello prolungato:

VDI	Kühlmitteldüse Coolant jet Ugello prolungato
25	KMD 0540
30	KMD 0845
40	KMD 0845

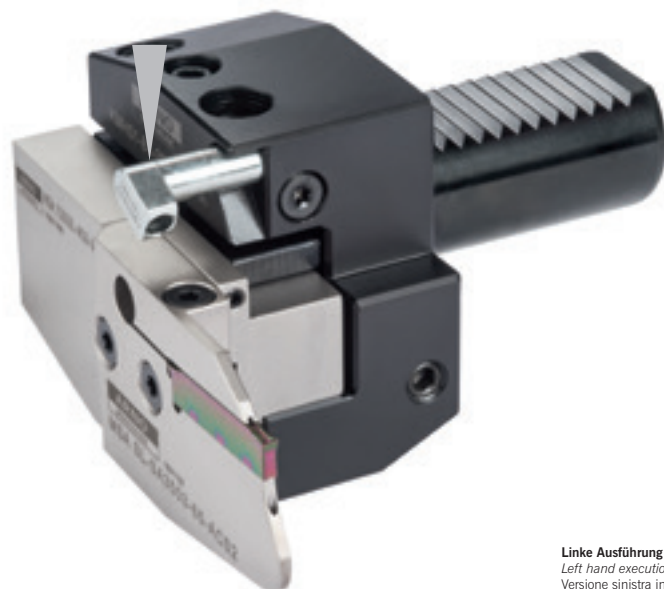

Nicht im Lieferumfang enthalten.
 Not included in the delivery.
 Non incluso.

Linke Ausführung abgebildet
 Left hand execution shown
 Versione sinistra in figura

Holder for SA-Modules HSA-7... for KMH holder (VDI)

Adattatori per moduli SA con adattatore KMH (VDI)

HSA...7...ACS-UN auf KMH01 – Form C

HSA...7...ACS-UN with KMH01 – Form C

HSA...7...ACS-UN con adattatore KMH01 – Forma C

1

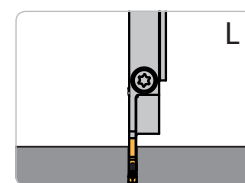
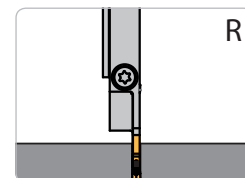

Linke Ausführung abgebildet
Left-hand execution shown
Versione sinistra in figura

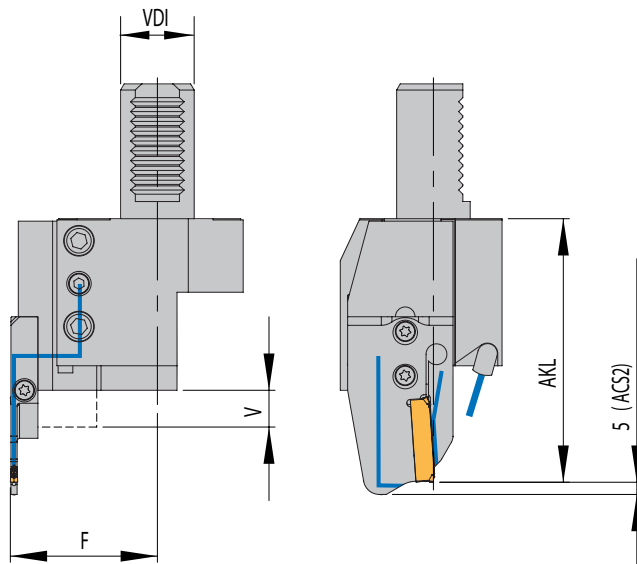

N NEU/NEW/NUOVO

Handling:

In Tabelle 1 den gewünschten KMH-Werkzeughalter (VDI) und den passenden Halter auswählen. Anhand Tabelle 2 dann – entsprechend dem Modul-Typ – das passende Modul (ab Seite 122) und den Schneideinsatz (ab Seite 132) bestimmen.

HANDLING:

Please select the KMH holder (VDI) and suitable holder from table 1. According to module type, please find suitable modules (starting page 122) and insert (starting page 132) from table 2.

GUIDA ALLA LETTURA:

Scegliere l'adattatore KMH (VDI) e tipologia di adattatore tabella 1. Dalla tabella 2 scegliere il relativo modulo (da pagina 122 in poi) ed inserto (da pagina 132 in poi).

KMH-Werkzeugaufnahme / KMH holder / Adattatore KMH

Form C für HSA-7-ACS-UN / Form C for HSA-7-ACS-UN / Forma C per HSA-7-ACS-UN

Form Forma	VDI	H _{Schaft} Shank Stelo	F	V*	KMH-Werkzeugaufnahme (VDI) KMH holder (VDI) Adattatore KMH (VDI)	PG 47	Halter SA-Module Holder SA-Module Adattatore per modulo SA	PG 37	Modul-Typ Module type Tipo Modulo
C1	25	16	52,0	15	KMH01-C1-25X16X55-IK	●	HSA 71629R-ACS-UN	●	MSA-SR..
	30	20	60,0	17	KMH01-C1-30X20X70-IK	●	HSA 72032R-ACS-UN	●	
	40	25	66,5	22	KMH01-C1-40X25X85-IK	●	HSA 72536R-ACS-UN	●	
C2	25	16	52,0	15	KMH01-C2-25X16X55-IK	●	HSA 71629L-ACS-UN	●	MSA-SL..
	30	20	60,0	17	KMH01-C2-30X20X70-IK	●	HSA 72032L-ACS-UN	●	
	40	25	66,5	22	KMH01-C2-40X25X85-IK	●	HSA 72536L-ACS-UN	●	
C3	25	16	52,0	15	KMH01-C3-25X16X55-IK	●	HSA 71629L-ACS-UN	●	MSA-SL..
	30	20	60,0	17	KMH01-C3-30X20X70-IK	●	HSA 72032L-ACS-UN	●	
	40	25	66,5	22	KMH01-C3-40X25X85-IK	●	HSA 72536L-ACS-UN	●	
C4	25	16	52,0	15	KMH01-C4-25X16X55-IK	●	HSA 71629R-ACS-UN	●	MSA-SR..
	25	20	56	17	KMH01-C4-25x20x70-IK	●	HSA72032R-ACS-UN	●	
	30	20	60,0	17	KMH01-C4-30X20X70-IK	●	HSA 72032R-ACS-UN	●	
	40	25	66,5	22	KMH01-C4-40X25X85-IK	●	HSA 72536R-ACS-UN	●	

* Der Halter kann um den Wert „V“ in der VDI-Aufnahme nach vorne geschoben werden.
Die Kühlmittelversorgung ist innerhalb des Stellbereichs durch eine mechanische Begrenzung sichergestellt. Das „AKL“-Maß ändert sich entsprechend.

Hinweis: Halter HSA...7... werden ohne Module geliefert.

* The tool holder can be extended by dimension „V“ in the VDI holder.
The coolant supply is guaranteed within the adjustment range by a mechanical limitation. Dimension „AKL“ changes accordingly.

Remark: Holders HSA-7... are supplied without modules.

* L'utensile può essere estratto dal portautensile del valore „V“ massimo.
L'adduzione del refrigerante è garantita tramite un fermo. Dimensione „AKL“ cambia in relazione.

Nota: Adattatori HSA-7 sono forniti senza modulo.

Ersatzteile wie Kühlmitteldüse und Schraube für Kühlmitteldüse finden Sie auf Seite 470 – 477

Spare parts like coolant jet and screw for coolant jet can be found on page 470 – 477

Ricambi come ugello refrigerante e vite per ugello refrigerante vedere pagina 470 – 477

Holder for SA-Modules HSA-7... for KMH holder (VDI)
 Adattatori per moduli SA con adattatore KMH (VDI)

Modul MSA-... / Module MSA-... / Modulo MSA-...

Modul-Typ Module type Tipo Modulo	AKL _{VDI25}	AKL _{VDI30}	AKL _{VDI40}
MSA-...-32-ACS	77.0	92.0	107.0
MSA-...-44-ACS	82.0	97.0	112.0
MSA-...-52-ACS	92.5	107.5	122.5
MSA-...-65-ACS	92.5	107.5	122.5
MSA-...-69-ACS	94,5	109,5	124,5
MSA-...-80-ACS	100,0	115,0	130,0
MSA-...-90-ACS	105,0	120,0	135,0
MSA-...-105-ACS	113,0	128,0	143,0

Tabelle 2 / Table 2 / Tabella 2

1

Einbaumöglichkeiten / Assembly options / Combinazioni di montaggio

Halter KMH01-C ... mit linkem Monoblockhalter und linkem Modul <i>Holder KMH01-C ...</i> <i>with left-hand Monoblockholder and left module</i> Adattatore KMH01-C ... con utensile monoblocco sinistro e modulo sinistro		Halter KMH01-C ... mit rechtem Monoblockhalter und rechtem Modul <i>Holder KMH01-C ...</i> <i>with right-hand Monoblockholder and right module</i> Adattatore KMH01-C ... con utensile monoblocco destro e modulo destro	
KMH01-C2 ...	KMH01-C3 ...	KMH01-C1 ...	KMH01-C4 ...
Einbaulage normal Normal assembly Montaggio normale	Einbaulage Überkopf Upside down assembly Montaggio invertito	Einbaulage normal Normal assembly Montaggio normale	Einbaulage Überkopf Upside down assembly Montaggio invertito

Zusätzliche Kühlung / Additional coolant / Ugello refrigerante prolungato

Ist eine zusätzliche Kühlung durch die externe Kühlmitteldüse erwünscht, bitte folgende Kühlmitteldüse verwenden:

If additional coolant is needed from external coolant jet, please use following part number:

In caso di assemblaggio con adattatori portamodulo sostituire l'ugello standard con quello prolungato:

VDI	Kühlmitteldüse Coolant jet Ugello prolungato
25	KMD 0540
30	KMD 0845
40	KMD 0845

Nicht im Lieferumfang enthalten.
 Not included in the delivery.
 Non incluso.

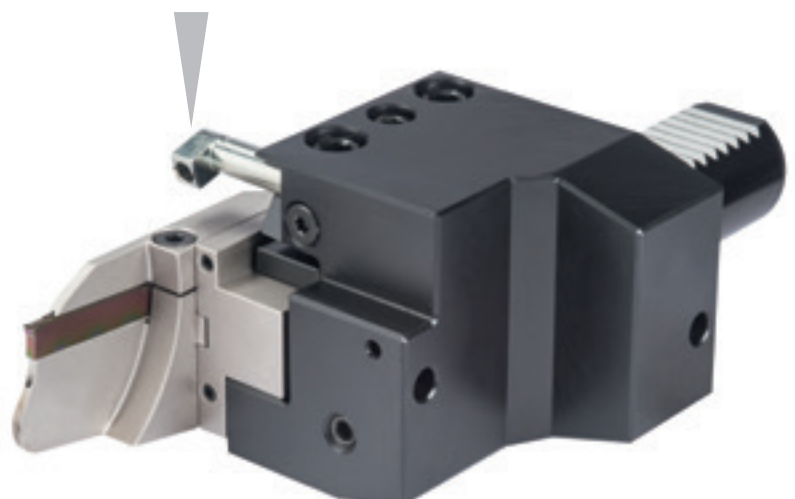

Linke Ausführung abgebildet
 Left-hand execution shown
 Versione sinistra in figura

1



Stechklingen / Part-off blades / Lame da taglio

Seite/Page/Pagina 96 – 111

 **ARNO® SpecialDesign** Seite/Page/Pagina 105 – 107



Spannblöcke / Clamping blocks / Blocchi portalama

Seite/Page/Pagina 112 – 113



Schneideinsätze / Inserts / Inserti

Seite/Page/Pagina 132 – 141

Stechklingen / Blades / Lame da taglio



1

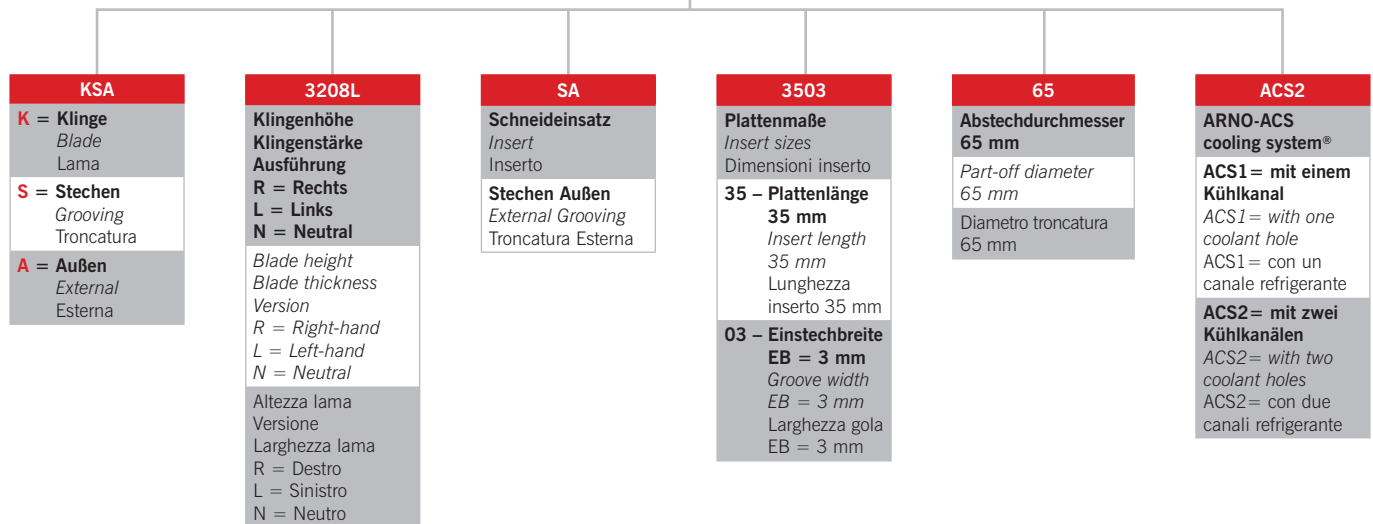

Schneideinsätze / Inserts / Inserti

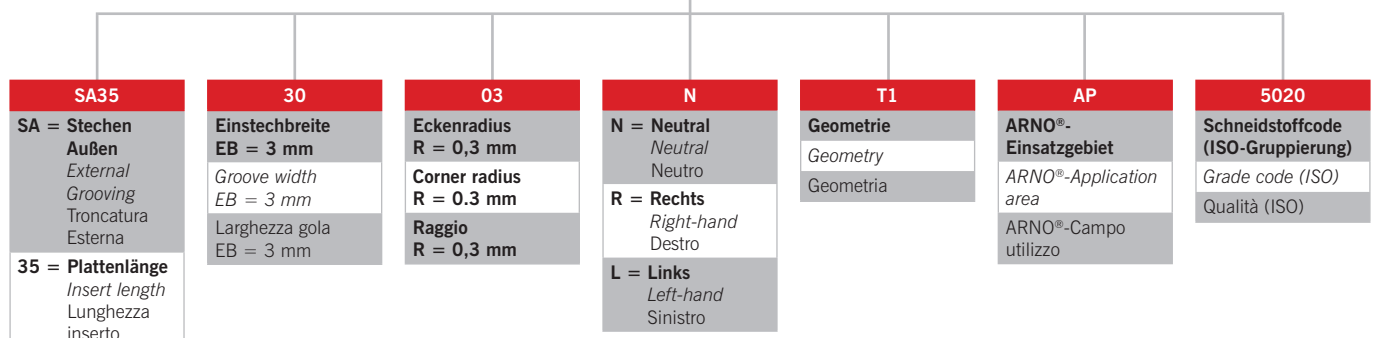

KSA-N

Selbstklemmende Stechklinge / Self-clamping blades / Lame a fissaggio elastico

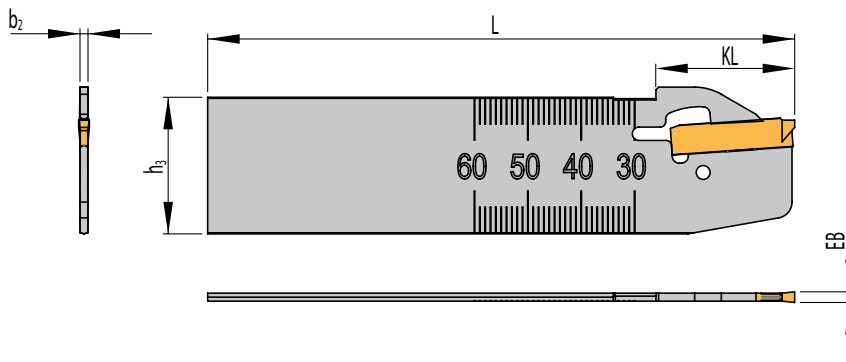

N NEU/NEW/NUOVO

Trägerwerkzeuge / Holders / Utensili

Bezeichnung Designation Articolo	EB	h ₃	b ₂	L	KL	PG 37	Schneideinsatz Insert Inserto
KSA 26025N	2,5	26	2,0	110	26	●	SA24-25...
KSA 2602N	2,0	26	1,5	110	26	●	SA24E-2002... / SA24-20...
KSA 2603N	3,0	26	2,5	110	26	●	SA24E-3003... / SA24-30...
KSA 32025N	2,5	32	2,0	110	-	●	SA24-25...
KSA 3202N	2,0	32	1,5	110	-	●	SA24E-2002... / SA24-20...
KSA 3203N	3,0	32	2,5	110	-	●	SA24E-3003... / SA24-30...
KSA 3203N-150	3,0	32	2,5	150	-	●	SA 24E-3003... / SA 24-30... / SE24-30...
KSA 3203N-SA35	3,0	32	2,5	150	-	●	SA35-30...
KSA 3204N-SA35	4,0	32	3,5	150	-	●	SA35-40...

Schlüssel ist hier NICHT im Lieferumfang enthalten.

Key is NOT included.

La chiave NON è inclusa.

Ersatzteile / Spare Parts / Ricambi

Trägerwerkzeug Holder Utensile	Schlüssel Key Chiave
KSA ..N..	S-KSA



Hinweis: Montageanleitung siehe Seite 151.

Remark: For assembly instructions please see page 151.

Nota: Istruzioni di montaggio a pagina 151.

KSA-N..-2

Selbstklemmende Stechklinge - zweiseitig / Self-clamping blade - double-sided /

Lame a bloccaggio elastico - bilaterale

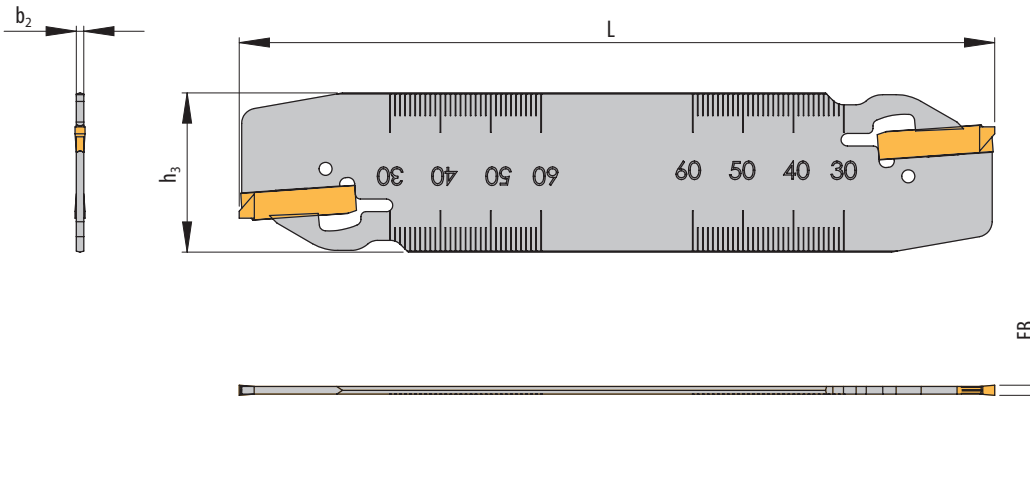

1

Trägerwerkzeuge / Holders / Utensili

Bezeichnung Designation Articolo	EB	h ₃	b ₂	L	PG 37	Schneideinsatz Insert Inserto
KSA 3202N-SA24-2	2	32	1,5	150	●	SA24E-20.. / SA24-20..
KSA 3203N-SA24-2	3	32	2,5	150	●	SA24E-30.. / SA24-30..

Schlüssel ist hier NICHT im Lieferumfang enthalten.

Key is NOT included.

La chiave NON è inclusa.

Ersatzteile / Spare Parts / Ricambi

Trägerwerkzeug Holder Utensile	Schlüssel Key Chiave
KSA ..N-2	S-KSA

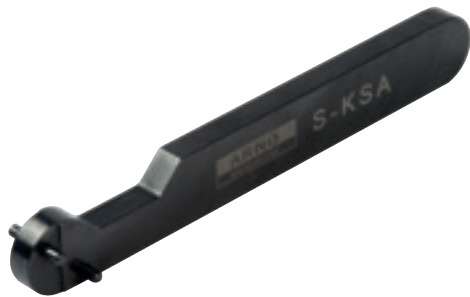

Hinweis: Montageanleitung siehe Seite 151.

Remark: For assembly instructions please see page 151.

Nota: Istruzioni di montaggio a pagina 151.

Part-off blades
Lame da taglio

KSA - Überkopf / KSA - Upside down / KSA - Rovesciata

Selbstklemmende Stechklinge in verstärkter Ausführung / Self-clamping blades in reinforced design / Lama a fissaggio elastico in versione rinforzata



1

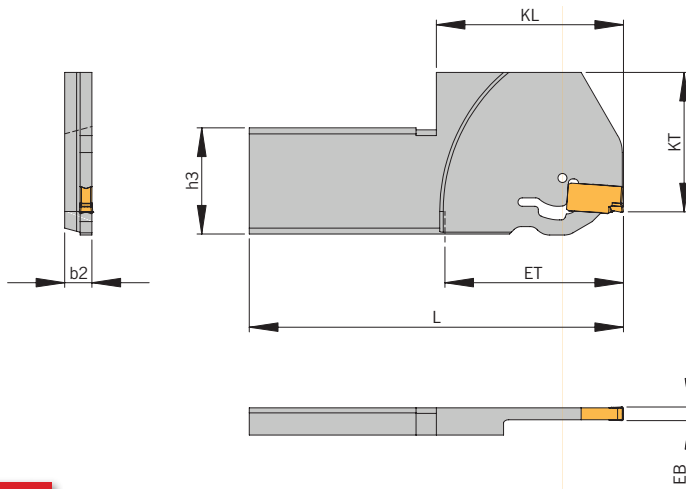

Rechte Ausführung Überkopf abgebildet.
Right-hand execution upside down shown.
Versione destra rovesciata in figura.

N NEU/NEW/NUOVO

Trägerwerkzeuge / Holders / Utensili

Bezeichnung Designation Articolo	EB	ET	D _{max}	h ₃	b ₂	L	KL	KT	PG 37	Schneideinsatz Insert Inserto
KSA 3208R-SA1704-105-ÜK ^N	4	52,5	105	32	8,0	110	55	41	●	SA 17-40...

D_{max} = Maximaler Durchmesser bei Vollmaterial

D_{max} = Maximum diameter in solid

D_{max} = Diametro massimo lavorazione dal pieno

Hinweis: Klinge passt auf die Direktaufnahme HVDI 30L-7-38-KSA-32LX

Remark: Part-off-blade suit to the flange mounted holder HVDI 30L-7-38-KSA-32LX

Nota: Queste lame sono predisposte per montaggio su attacchi base HVDI-30L-7-38-KSA-32LX

Schlüssel ist hier NICHT im Lieferumfang enthalten.

Key is NOT included.

La chiave NON è inclusa.

Ersatzteile / Spare Parts / Ricambi

Trägerwerkzeug Holder Utensile	Schlüssel Key Chiave
KSA 3208..-ÜK	S-KSA

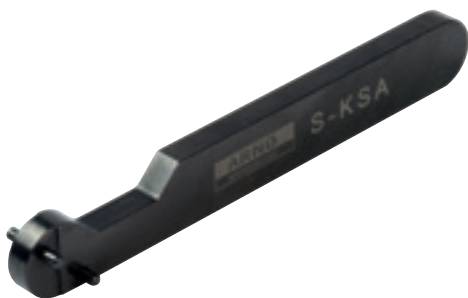

Hinweis: Montageanleitung siehe Seite 151.

Remark: For assembly instructions please see page 151.

Nota: Istruzioni di montaggio a pagina 151.

Part-off blades
Lame da taglio

KSA

Für EMCO-/Index-/Traub-Maschinen

For EMCO /Index /Traub Machines

Per macchine utensili tipo EMCO /Index /Traub

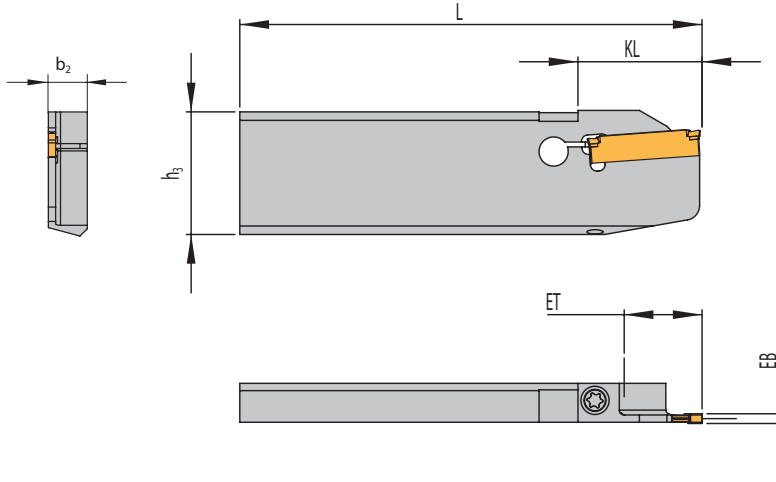
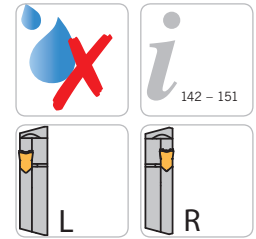

Linke Ausführung abgebildet
Left-hand execution shown
Versione sinistra in figura

Trägerwerkzeuge / Holders / Utensili

Bezeichnung Designation Articolo	EB	ET	D _{max}	D _R	h ₃	b ₂	L	KL	PG 37	Schneideinsatz Insert Inserto
KSA 260895L/R-SA1602-20	2,0	10	20	-	26	8,0	95	19,5	●	SA 16-20...
KSA 260895L-SA24015-20	1,5	10	20	-	26	8,0	95	19,5	●	SA 24-15...
KSA 260895L/R-SA2402-32	2,0	16	32	-	26	8,0	95	25,5	●	SA 24-20...
KSA 260895L/R-SA2403-32	3,0	16	32	-	26	8,0	95	25,5	●	SA 24-30...
KSA 260895L/R-SA2403-44	3,0	22	44	61	26	8,0	95	31,5	●	SA 24-30...
KSA 260895R-SA24015-32	1,5	16	32	-	26	8,0	95	25,5	●	SA 24-15...
KSA 320895L/R-SA2402-44	2,0	22	44	61	32	8,0	95	31,5	●	SA 24-20...
KSA 320895L/R-SA2403-44	3,0	22	44	61	32	8,0	95	31,5	●	SA 24-30...

D_{max} = Maximaler Durchmesser bei Vollmaterial, D_R = Maximaler Stechdurchmesser bei Rohren

D_{max} = Maximum diameter in solid, D_R = Maximum diameter for tube material

D_{max} = Diametro massimo lavorazione dal pieno, D_R = Diametro massimo da tubo

Ersatzteile / Spare Parts / Ricambi

Trägerwerkzeug Holder Utensile	Schraube Screw Vite	Schlüssel Key Chiave
KSA 260895.. - KSA 320895..	AS 0022	T5115-IP

Part-off blades
Lame da taglio

KSA - Überkopf / KSA - Upside down / KSA - Rovesciata

Stechklingen einsetzbar auf EMCO- / Index- / Traub-Maschinen

Part-off blades suitable for EMCO / Index / Traub Machines

Lame da taglio per macchine utensili tipo EMCO / Index / Traub

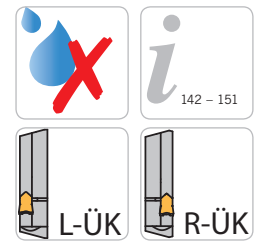

1

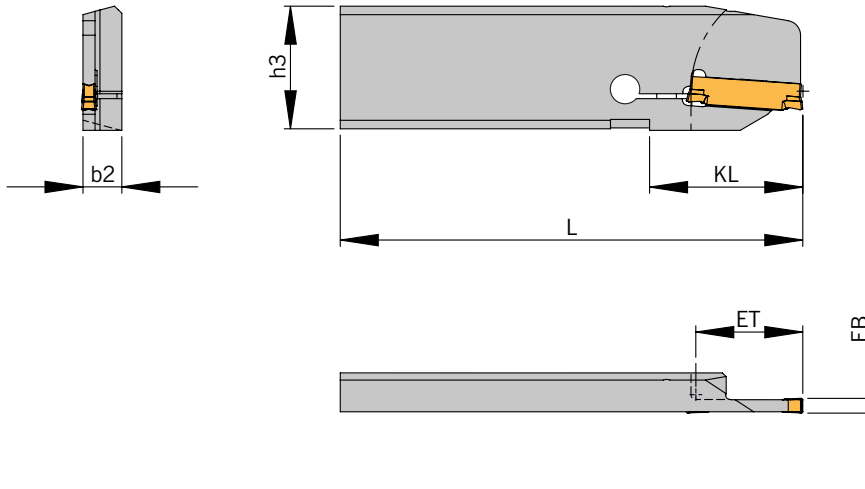

Linke Ausführung Überkopf abgebildet.
Left-hand execution upside down shown.
Versione sinistra rovesciata in figura.

Trägerwerkzeuge / Holders / Utensili

Bezeichnung Designation Articolo	EB	ET	D _{max}	D _R	h ₃	b ₂	L	KL	PG 37	Schneideinsatz Insert Inserto
KSA 260895R-SA24015-20-ÜK	1,5	10	20	-	26	8,0	95	19,5	●	SA 24-15...
KSA 260895R-SA24015-32-ÜK	1,5	16	32	-	26	8,0	95	25,5	●	SA 24-15...
KSA 260895L/R-SA24015-44-ÜK	1,5	22	44	61	26	8,0	95	31,5	●	SA 24-15...
KSA 260895L/R-SA2403-32-ÜK	3,0	16	32	-	26	8,0	95	25,5	●	SA 24-30...
KSA 260895L/R-SA2403-44-ÜK	3,0	22	44	61	26	8,0	95	31,5	●	SA 24-30...
KSA 320895L/R-SA2402-44-ÜK	2,0	22	44	61	32	8,0	95	31,5	●	SA 24-20...
KSA 320895L/R-SA2403-44-ÜK	3,0	22	44	61	32	8,0	95	31,5	●	SA 24-30...

D_{max} = Maximaler Durchmesser bei Vollmaterial, D_R = Maximaler Stechdurchmesser bei Rohren

D_{max} = Maximum diameter in solid, D_R = Maximum diameter for tube material

D_{max} = Diametro massimo lavorazione dal pieno, D_R = Diametro massimo da tubo

Ersatzteile / Spare Parts / Ricambi

Trägerwerkzeug Holder Utensile	Schraube Screw Vite	Schlüssel Key Chiave
KSA 260895.. - KSA 320895..	AS 0022	T5115-IP

Part-off blades
Lame da taglio

KSA

Stechklingen einsetzbar auf Traub TNK36 / TNL32 / TNL26K und Index MS 18C - verstärkte Ausführung

Part-off blades suitable for Traub TNK36 / TNL32 / TNL26K and Index MS 18C - Reinforced blade design

Lame de taglio per macchine Traub TNK36 / TNL32 / TNL26K e Index MS 18C - Lama rinforzata da taglio

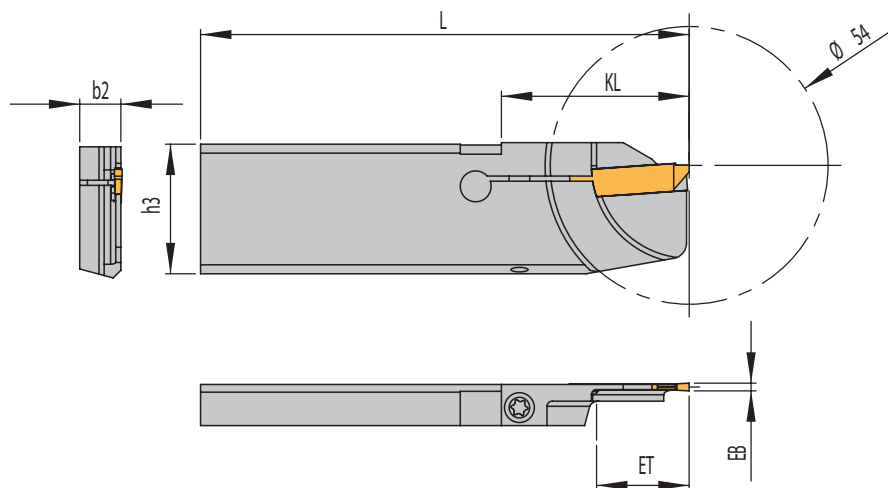
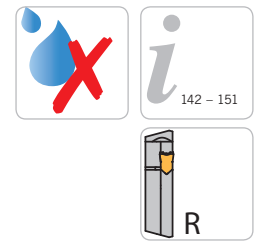

Rechte Ausführung abgebildet.
Right-hand execution shown.
Versione destra in figura.

Trägerwerkzeuge / Holders / Utensili

Bezeichnung Designation Articolo	EB	ET	D _{max}	h ₃	b ₂	L	KL	PG 37	Schneideinsatz Insert Inserito
KSA 260895R-SA24015-S1-36	1,5	18	36	26	8,0	95	36,5	●	SA 24-15...
KSA 260895R-SA2402-S1-36	2,0	18	36	26	8,0	95	36,5	●	SA 24-20...

D_{max} = Maximaler Durchmesser bei Vollmaterial

D_{max} = Maximum diameter in solid

D_{max} = Diametro massimo lavorazione dal pieno

Ersatzteile / Spare Parts / Ricambi

Trägerwerkzeug Holder Utensile	Schraube Screw Vite	Schlüssel Key Chiave
KSA 260895..	AS 0022	T5115-IP

KSA

Stechklinge / Part-off blade / Lama de taglio

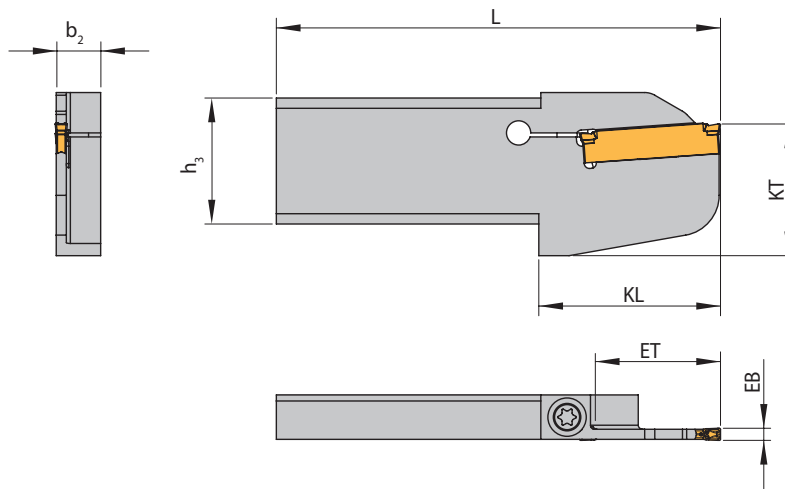
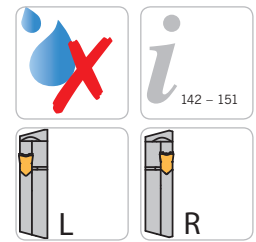

Linke Ausführung abgebildet
Left-hand execution shown
Versione sinistra in figura

Trägerwerkzeuge / Holders / Utensili

Bezeichnung Designation Articolo	EB	ET	D _{max}	D _R	h ₃	b ₂	L	KL	KT	PG 37	Schneideinsatz Insert Inserto
KSA 2608L/R-SA24015-20	1,5	10,0	20	-	26	8,0	110	-	-	●	SA 24-15...
KSA 2608L-SA24015-32	1,5	16,0	32	-	26	8,0	110	-	-	●	SA 24-15...
KSA 2608L/R-SA24015-44	1,5	22,0	44	61	26	8,0	110	-	-	●	SA 24-15...
KSA 2608L/R-SA2402-32	2,0	16,0	32	-	26	8,0	110	-	-	●	SA 24-20...
KSA 2608L/R-SA2402-44	2,0	22,0	44	61	26	8,0	110	-	-	●	SA 24-20...
KSA 2608L/R-SA2403-26	3,0	13,0	26	-	26	8,0	110	-	-	●	SA 24-30...
KSA 2608L/R-SA3502-65	2,0	32,5	65	80	26	8,0	110	45	29,0	●	SA 35-20...
KSA 2608L/R-SA3503-65	3,0	32,5	65	80	26	8,0	110	45	29,0	●	SA 35-30...
KSA 2611L/R-SA3503-65	3,0	32,5	65	80	26	11,0	110	45	29,0	●	SA 35-30...
KSA 3208L/R-SA2402-44	2,0	22,0	44	61	32	8,0	110	-	-	●	SA 24-20...
KSA 3208L/R-SA3502-65	2,0	32,5	65	80	32	8,0	110	45	32,5	●	SA 35-20...
KSA 3208L/R-SA3503-65	3,0	32,5	65	80	32	8,0	110	45	32,5	●	SA 35-30...
KSA 3208L/R-SA3504-65	4,0	32,5	65	80	32	8,0	110	45	32,5	●	SA 35-40...
KSA 3211L/R-SA3503-65	3,0	32,5	65	80	32	11,0	110	45	32,5	●	SA 35-30...

D_{max} = Maximaler Durchmesser bei Vollmaterial, D_R = Maximaler Stechdurchmesser bei Rohren

D_{max} = Maximum diameter in solid, D_R = Maximum diameter for tube material

D_{max} = Diametro massimo lavorazione dal pieno, D_R = Diametro massimo da tubo

Ersatzteile / Spare Parts / Ricambi

Trägerwerkzeug Holder Utensile	Schraube Screw Vite	Schlüssel Key Chiave
KSA ..08 R/L -SA24..	AS 0022	T5115-IP
KSA ..08 R/L -SA35..	AS 0045	T5220-IP
KSA ..11 R/L -SA35..	SA5T	T5220-IP

Part-off blades
Lame da taglio

KSA - Überkopf / KSA - Upside down / KSA - Rovesciata Stechklinge / Part-off blade / Lama de taglio

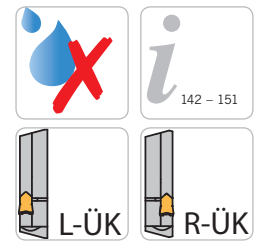
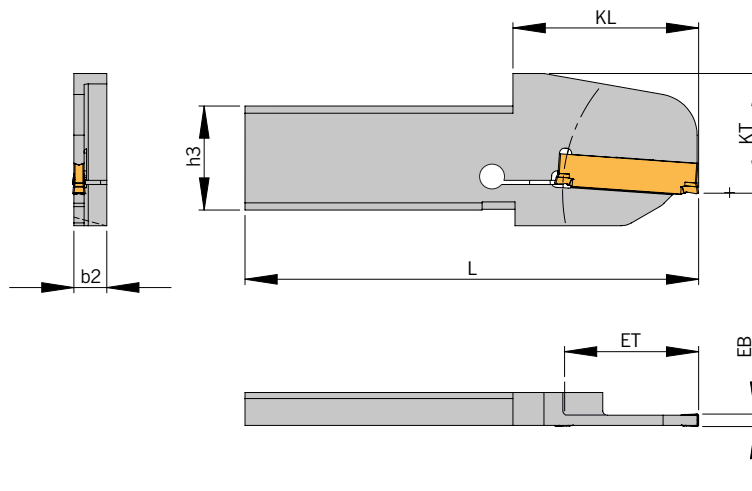

1

Linke Ausführung Überkopf abgebildet.
Left-hand execution upside down shown.
Versione sinistra rovesciata in figura.

Trägerwerkzeuge / Holders / Utensili

Bezeichnung Designation Articolo	EB	ET	D _{max}	D _R	h ₃	b ₂	L	KL	KT	PG 37	Schneideinsatz Insert Inserto
KSA 2608L-SA24015-32-ÜK	1,5	16,0	32	-	26	8,0	110	-	-	●	SA 24-15...
KSA 2608L/R-SA24015-44-ÜK	1,5	22,0	44	61	26	8,0	110	-	-	●	SA 24-15...
KSA 2608L/R-SA2402-32-ÜK	2,0	16,0	32	-	26	8,0	110	-	-	●	SA 24-20...
KSA 2608L/R-SA2402-44-ÜK	2,0	22,0	44	61	26	8,0	110	-	-	●	SA 24-20...
KSA 2608L/R-SA3502-65-ÜK	2,0	32,5	65	80	26	8,0	110	45	29,0	●	SA 35-20...
KSA 2608L/R-SA3503-65-ÜK	3,0	32,5	65	80	26	8,0	110	45	29,0	●	SA 35-30...
KSA 2611L/R-SA3503-65-ÜK	3,0	32,5	65	80	26	11,0	110	45	29,0	●	SA 35-30...
KSA 3208L/R-SA2402-44-ÜK	2,0	22,0	44	61	32	8,0	110	-	-	●	SA 24-20...
KSA 3208L/R-SA3502-65-ÜK	2,0	32,5	65	80	32	8,0	110	45	32,5	●	SA 35-20...
KSA 3208L/R-SA3503-65-ÜK	3,0	32,5	65	80	32	8,0	110	45	32,5	●	SA 35-30...
KSA 3208L/R-SA3504-65-ÜK	4,0	32,5	65	80	32	8,0	110	45	32,5	●	SA 35-40...
KSA 3211L/R-SA3503-65-ÜK	3,0	32,5	65	80	32	11,0	110	45	32,5	●	SA 35-30...
KSA 3211L/R-SA3504-65-ÜK	4,0	32,5	65	80	32	11,0	110	45	32,5	●	SA 35-40...

D_{max} = Maximaler Durchmesser bei Vollmaterial, D_R = Maximaler Stechdurchmesser bei Rohren

D_{max} = Maximum diameter in solid, D_R = Maximum diameter for tube material

D_{max} = Diametro massimo lavorazione dal pieno, D_R = Diametro massimo da tubo

Ersatzteile / Spare Parts / Ricambi

Trägerwerkzeug Holder Utensile	Schraube Screw Vite	Schlüssel Key Chiave
KSA ..08 R/L -SA24..	AS 0022	T5115-IP
KSA ..08 R/L -SA35..	AS 0045	T5220-IP
KSA ..11 R/L -SA35..	SA5T	T5220-IP

H-KSA-IK

Halbzeuge / Stechklingen mit Innenkühlung - verstärkte Ausführung

Blanks / Part-off blades with through tool coolant - Reinforced blade design

Semilavorato / Lame da taglio con adduzione interna - Lama rinforzata da taglio



1

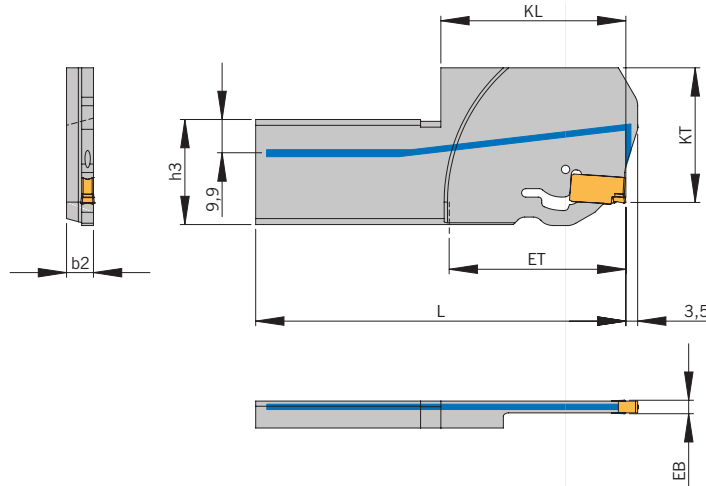

Halbzeuge für individuelle Kühlmittelübergabe.
Blanks for individual coolant access.
Semilavorati per il passaggio interno specifico del refrigerante.

Rechte Ausführung Überkopf abgebildet.
Right-hand execution upside down shown.
Versione destra rovesciata in figura.

NEU/NEW/NUOVO

Trägerwerkzeuge / Holders / Utensili

Bezeichnung Designation Articolo	EB	ET	D _{max}	h ₃	b ₂	L	KL	KT	PG 37	Schneideinsatz Insert Inserto
H-KSA 3208R-SA1703-105-ÜK-IK	3	52,5	105	32	8,0	110	55	40	●	SA 17-30... / HVDI 30..LX
H-KSA 3208R-SA1704-105-ÜK-IK	4	52,5	105	32	8,0	100	55	40	●	SA 17-40... / HVDI 30..LX

D_{max} = Maximaler Durchmesser bei Vollmaterial

D_{max} = Maximum diameter in solid

D_{max} = Diametro massimo lavorazione dal pieno

Hinweis: Klingen passen auf die Direktaufnahme HVDI30...LX

Remark: Part-off-blades suit to the flange mounted holder HVDI30...LX

Nota: Queste lame sono predisposte per montaggio su attacchi base HVDI30...LX

Ersatzteile / Spare Parts / Ricambi

Trägerwerkzeug Holder Utensile	Schlüssel Key Chiave
H-KSA 3208.. -ÜK-IK	S-KSA

ARNO® SpecialDesign

Diese Stechklinge bekommen Sie mit Ihren spezifischen Maßen der Kühlmittelübergabe. Ein Anfrageblatt hierzu finden Sie auf der nächsten Seite oder im Internet unter: www.arno.de/service/downloads

The coolant inlet can be supplied to your specification, please complete enquiry sheet on the next page or download this from: www.arno.de/service/downloads

Il passaggio interno del refrigerante può essere predisposto in base alle specifiche esigenze del cliente, completare il modulo alla pagina seguente oppure scaricarlo da www.arno.de/service/downloads

Halbzeuge / Stechklingen mit Innenkühlung - verstärkte Ausführung

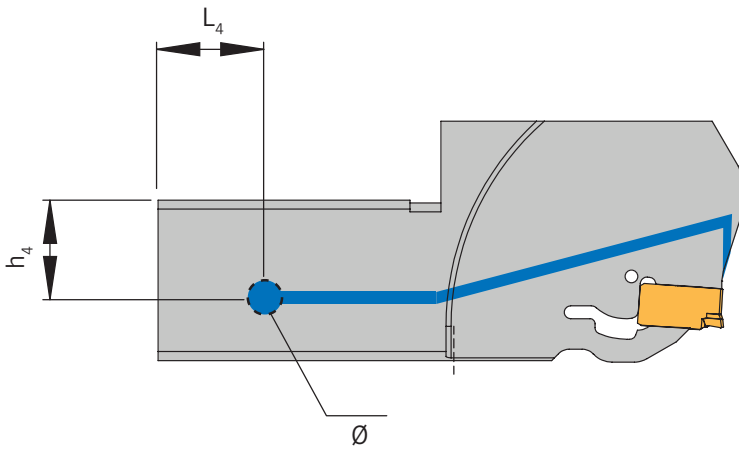

1

Preis auf Anfrage.

Bezeichnung	L_4	h_4	\varnothing
<input type="text"/>	<input type="text"/>	<input type="text"/>	<input type="text"/>

Download dieses Formulares unter: www.arno.de/service/downloads

Blanks / Part-off blades with through tool coolant - Reinforced blade design

 **ARNO®** SpecialDesign

1

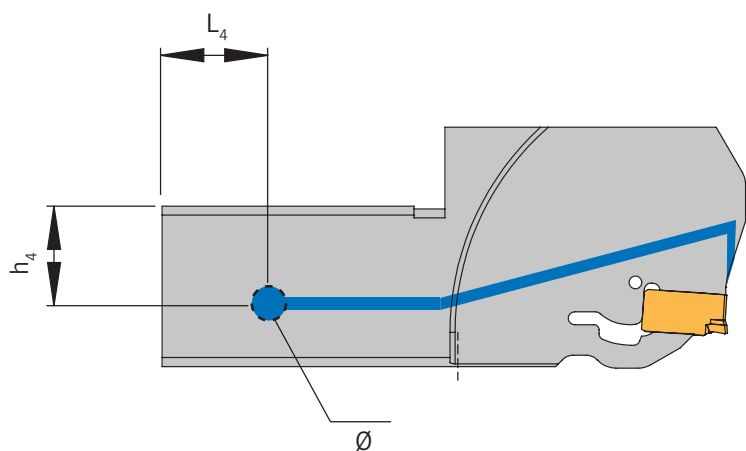

Price on request.

Designation	L_4	h_5	\emptyset
<input type="text"/>	<input type="text"/>	<input type="text"/>	<input type="text"/>

Download this form from: www.arno.de/service/downloads

Semilavorato / Lame da taglio con adduzione interna -
Lama rinforzata da taglio

ARNO® SpecialDesign

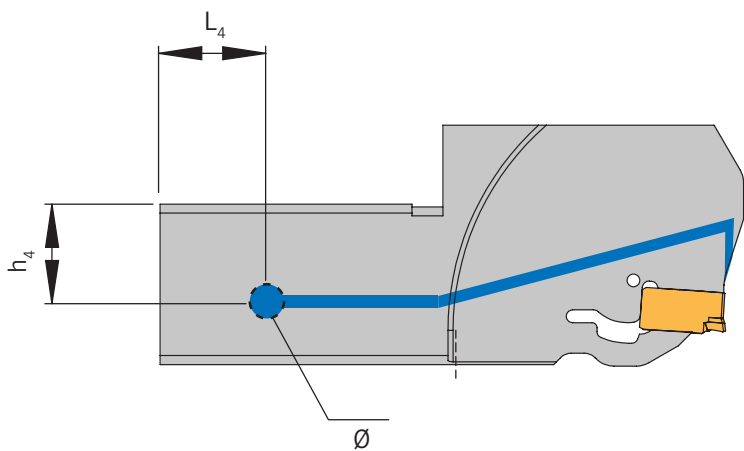

1

Prezzi su richiesta.

Articolo	L_4	h_5	\emptyset
<input type="text"/>	<input type="text"/>	<input type="text"/>	<input type="text"/>

Download del formula da: www.arno.de/service/downloads

KSA-ACS2

Stechklinge einsetzbar auf Traub TNL26 / TNL32 und TNK36 - mit ACS

Part-off blade suitable for Traub TNL26 / TNL32 and TNK36 - with ACS

Lama da taglio per macchine Traub TNL26 / TNL32 e TNK36 - con ACS

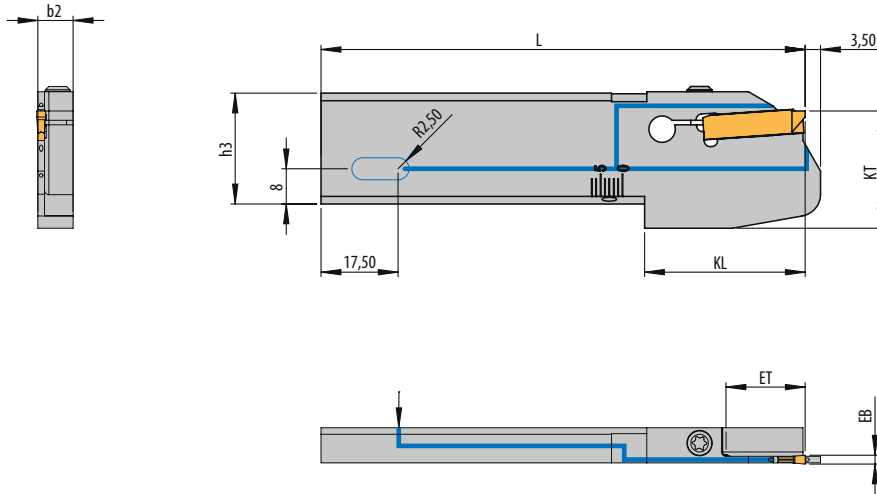
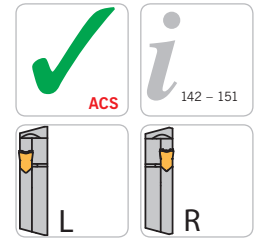

Linke Ausführung abgebildet
Left-hand execution shown
Versione sinistra in figura

Trägerwerkzeuge / Holders / Utensili

Bezeichnung Designation Articolo	EB	ET	D _{max}	D _R	h ₃	b ₂	L	KL	KT	PG 37	Schneideinsatz Insert Inserto
KSA 2608R-SA2402-28-ACS2	2	14	28	28	26	8,0	110	36,5	26,6	●	SA 24-20...
KSA 2608L-SA2402-36-ACS2	2	18	36	36	26	8,0	110	36,5	26,6	●	SA 24-20...
KSA 2608L-SA2403-44-ACS2	3	22	44	61	26	8,0	110	36,5	26,6	●	SA 24-30...

D_{max} = Maximaler Durchmesser bei Vollmaterial, D_R = Maximaler Stechdurchmesser bei Rohren

D_{max} = Maximum diameter in solid, D_R = Maximum diameter for tube material

D_{max} = Diametro massimo lavorazione dal pieno, D_R = Diametro massimo da tubo

Ersatzteile / Spare Parts / Ricambi

Trägerwerkzeug Holder Utensile	Schraube Screw Vite	Schlüssel Key Chiave
KSA ..08.. -SA24..	AS 0022	T5215-IP

KSA-TR-ACS2

Steckklinge einsetzbar auf Traub TNL26 / TNL32 und TNK36 - mit ACS

Part-off blade suitable for Traub TNL26 / TNL32 and TNK36 - with ACS

Lama da taglio per macchine Traub TNL26 / TNL32 e TNK36 - con ACS

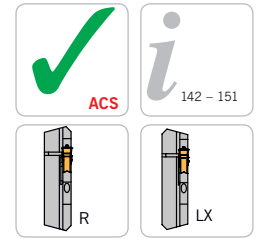
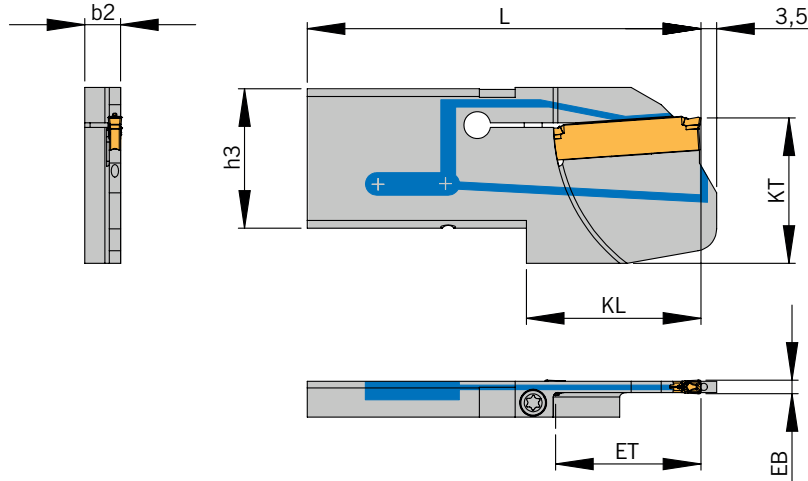

1

Rechte Ausführung abgebildet
Right-hand execution shown
Versione destra in figura

N NEU/NEW/NUOVO

Trägerwerkzeuge / Holders / Utensili

Bezeichnung Designation Articolo	EB	ET	D _{max}	D _R	h ₃	b ₂	L	KL	KT	PG 37	Schneideinsatz Insert Inserto
KSA-TR-2608R-SA2402-36-ACS2** N	2	18,0	36	36	26	8,0	74	25	26,6	●	SA 24-20...
KSA-TR-2608R-SA2403-44-ACS2** N	3	22,0	44	61	26	8,0	78	29	26,6	●	SA 24-30...
KSA-TR-3208LX-SA2403-44-ACS2* N	3	22,0	44	61	32	8,0	100	31	32,5	●	SA 24-30...
KSA-TR-3208LX-SA3503-65-ACS2* N	3	32,5	65	80	32	8,0	110	41	32,5	●	SA 35-30...
KSA-TR-3208R-SA3503-65-ACS2*** N	3	32,5	65	80	32	8,0	88	39	32,5	●	SA 35-30...

D_{max} = Maximaler Durchmesser bei Vollmaterial, D_R = Maximaler Stechdurchmesser bei Rohren

D_{max} = Maximum diameter in solid, D_R = Maximum diameter for tube material

D_{max} = Diametro massimo lavorazione dal pieno, D_R = Diametro massimo da tubo

* Klinge passt auf die Direktaufnahme HTR45-R-W7040098-KSA-32LX-ACS

* Part-off-blade suit to the flange mounted holder HTR45-R-W7040098-KSA-32LX-ACS

* Queste lame sono predisposte per montaggio su attacchi base HTR45-R-W7040098-KSA-32LX-ACS

** Klinge passt auf die Direktaufnahme W7040096

** Part-off-blade suit to the flange mounted holder W7040096

** Queste lame sono predisposte per montaggio su attacchi base W7040096

*** Klinge passt auf die Direktaufnahme W7040097

*** Part-off-blade suit to the flange mounted holder W7040097

*** Queste lame sono predisposte per montaggio su attacchi base W7040097

Ersatzteile / Spare Parts / Ricambi

Trägerwerkzeug Holder Utensile	Schraube Screw Vite	Schlüssel Key Chiave
KSA-TR ..08.. -ACS2	AS 0022	T5215-IP

KSA-TR-S1-ACS2

Stechklinge einsetzbar auf Traub TNL18 / TNL20 / TNL32 und Index MS22 - mit ACS
 Part-off blade suitable for Traub TNL18 / TNL20 / TNL32 and Index MS22 - with ACS
 Lama da taglio per macchine Traub TNL18 / TNL20 / TNL32 e Index MS22 - con ACS

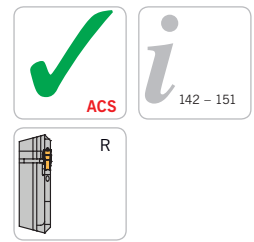

1

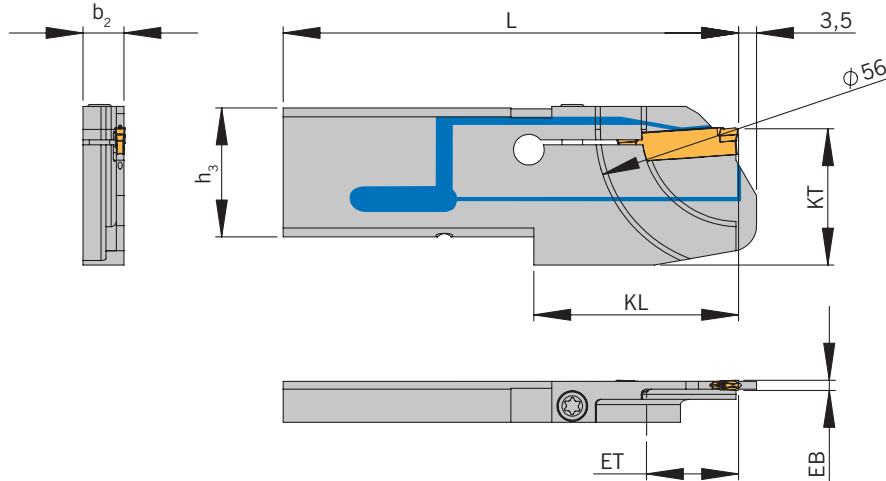

Rechte Ausführung abgebildet
 Right-hand execution shown
 Versione destra in figura

N NEU/NEW/NUOVO

Trägerwerkzeuge / Holders / Utensili

Bezeichnung Designation Articolo	EB	ET	D _{max}	D _R	h ₃	b ₂	L	KL	KT	PG 37	Schneideinsatz Insert Inserto
KSA-TR-2608R-SA2402-S1-36-ACS2	2	18,0	36	36	26	8,0	89	40	26,6	●	SA 24-20...

D_{max} = Maximaler Durchmesser bei Vollmaterial, D_R = Maximaler Stechdurchmesser bei Rohren

D_{max} = Maximum diameter in solid, D_R = Maximum diameter for tube material

D_{max} = Diametro massimo lavorazione dal pieno, D_R = Diametro massimo da tubo

Klinge passt auf die Direktaufnahme W7040096

Part-off-blade suit to the flange mounted holder W7040096

Queste lame sono predisposte per montaggio su attacchi base W7040096

Ersatzteile / Spare Parts / Ricambi

Trägerwerkzeug Holder Utensile	Schraube Screw Vite	Schlüssel Key Chiave
KSA-TR ..08.. -ACS2	AS 0022	T5215-IP

KSA-ACS2

Stechklinge mit ACS für VDI-Direktaufnahmen / Part-off blade with ACS for VDI flange mounted holders / Lama da taglio con ACS per attacchi base VDI

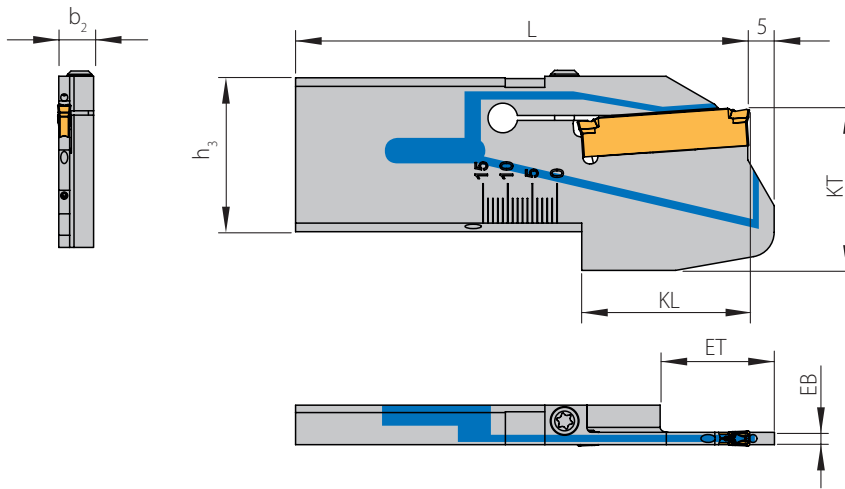
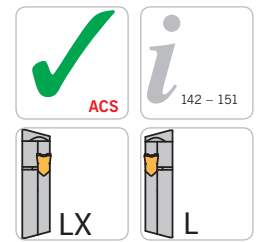

1

Trägerwerkzeuge / Holders / Utensili

Bezeichnung Designation Articolo	EB	ET	D _{max}	h ₃	b ₂	L	KL	KT	PG 37	Schneideinsatz Insert Inserto
KSA 3208L-SA2403-44-ACS2*	3	22,0	44	32	8,0	81,5	23,5	32,5	●	SA 24-30...
KSA 3208LX-SA2403-44-ACS2**	3	22,0	44	32	8,0	81,5	23,5	32,5	●	SA 24-30...
KSA 3208L-SA3503-65-ACS2*	3	32,5	65	32	8,0	92,0	34,0	32,5	●	SA 35-30...
KSA 3208LX-SA3503-65-ACS2**	3	32,5	65	32	8,0	92,0	34,0	32,5	●	SA 35-30...

D_{max} = Maximaler Durchmesser bei Vollmaterial

D_{max} = Maximum diameter in solid

D_{max} = Diametro massimo lavorazione dal pieno

* Klinge passt auf die Direktaufnahme HVDI-30R-7-38-KSA-32L und HVDI-30L-7-60-KSA-32L.

* Part-off-blade suit to the flange mounted holder HVDI-30R-7-38-KSA-32L and HVDI-30L-7-60-KSA-32L.

* Queste lame sono predisposte per montaggio su attacchi base HVDI-30R-7-38-KSA-32L e HVDI-30L-7-60-KSA-32L.

** Klinge passt auf die Direktaufnahme HVDI-30L-7-38-KSA-32LX und HVDI-30R-7-60-KSA-32LX.

** Part-off-blade suit to the flange mounted holder HVDI-30L-7-38-KSA-32LX and HVDI-30R-7-60-KSA-32LX.

** Queste lame sono predisposte per montaggio su attacchi base HVDI-30L-7-38-KSA-32LX e HVDI-30R-7-60-KSA-32LX.

Ersatzteile / Spare Parts / Ricambi

Trägerwerkzeug Holder Utensile	Schraube Screw Vite	Schlüssel Key Chiave
KSA 3208.. - ACS2	AS 0022	T5115-IP

SBN

Spannblock mit Kühlmitteldüse / Clamping block with coolant jet / Blocco portalama con ugello refrigerante

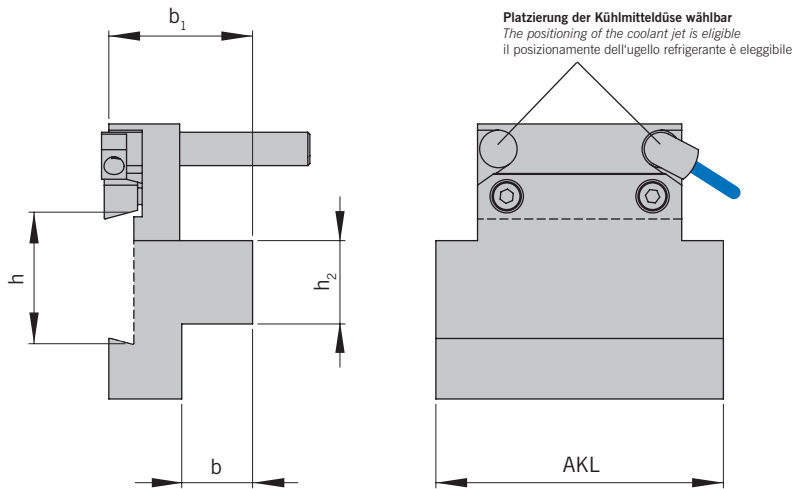

Trägerwerkzeuge / Holders / Utensili

Bezeichnung Designation Articolo	h_2	b	h_3	AKL	b_1	h	PG 37	Stechklinge Blade Lama
SBN-16-26	16	13	26	54	30,5	55	●	KSA 26...
SBN-16-32	16	13	32	54	30,5	61	●	KSA 32...
SBN-20-26	20	17	26	69	64,5	66	●	KSA 26...
SBN-20-32	20	17	32	69	34,5	66	●	KSA 32...
SBN-25-26	25	21	26	84	41,5	76	●	KSA 26...
SBN-25-32	25	21	32	84	41,5	76	●	KSA 32...
SBN-32-32	32	23.5	32	99	44,0	80	●	KSA 32...

Hinweis : In der Spitzenhöhe muss das Werkzeug auf 0 / $\pm 0,1$ mm eingesellt werden.Information : The tool should be setup in centre high to 0 / $\pm 0,1$ mm.

Indicazione : l'utensile deve essere regolato a 0 / -0,1 mm in rapporto all'altezza del centro.

SBN Spannblock mit radial und axial verstellbarer Kühlmitteldüse

SBN clamping block with radial and axial adjustable coolant jet

SBN blocco portalama con getto regolabile radiale e assiale

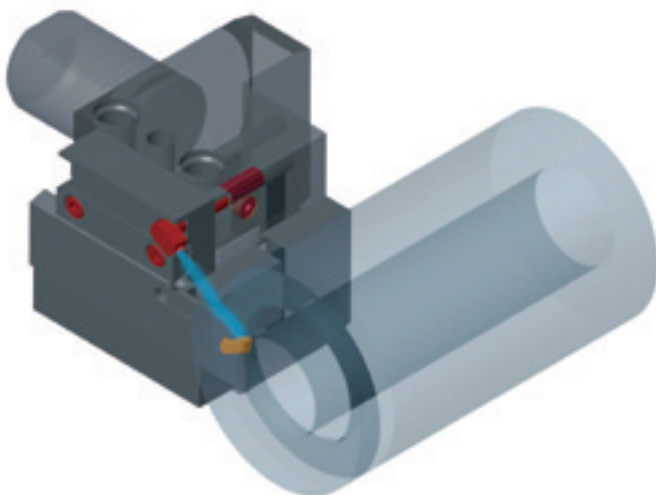

SBN

Spannblock / Clamping block / Blocco portalama

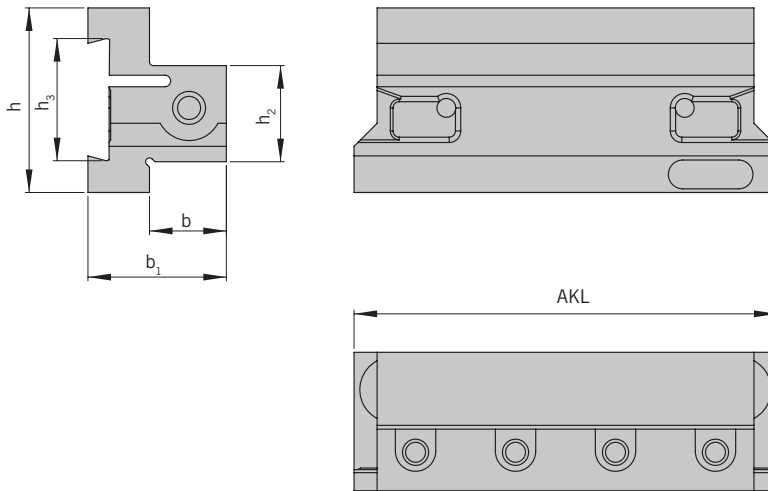

Trägerwerkzeuge / Holders / Utensili

Bezeichnung Designation Articolo	h_2	b	h_3	AKL	b_1	h	PG 37	Stechklinge Blade Lama
SBN 2020-26 K	20	20	26	90	33,0	39	●	KSA 26...
SBN 2520-32 K	25	20	32	110	36,0	48	●	KSA 32...
SBN 3229-32 K	32	29	32	120	44,5	48	●	KSA 32...

Hinweis : In der Spitzenhöhe muss das Werkzeug auf 0 / $\pm 0,1$ mm eingesellt werden.Information : The tool should be setup in centre high to 0 / $\pm 0,1$ mm.

Indicazione : l'utensile deve essere regolato a 0 / -0,1 mm in rapporto all'altezza del centro.

1



Halter für SA-Module (MSA) / Tool holders for SA-Modules (MSA) / Steli per moduli SA (MSA)

Seite/Page/Pagina **116 – 117**

 **ARNO® SpecialDesign** Seite/Page/Pagina **118**



Module / Modules / Moduli

Seite/Page/Pagina **122 – 128**



Schneideinsätze / Inserts / Inserti

Seite/Page/Pagina **132 – 141**

Module / Modules / Moduli



1

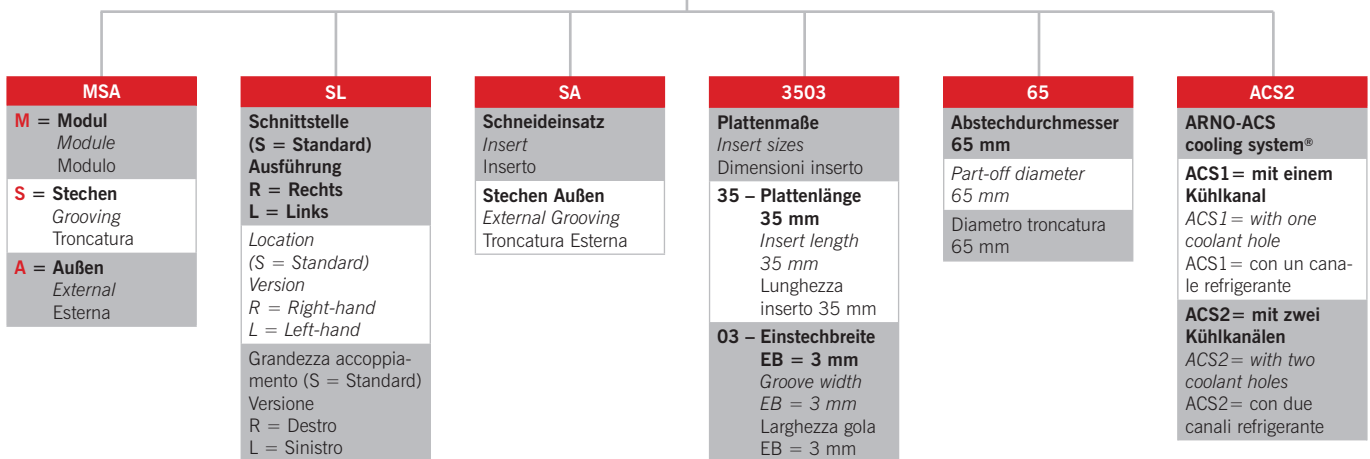

Schneideinsätze / Inserts / Inserti

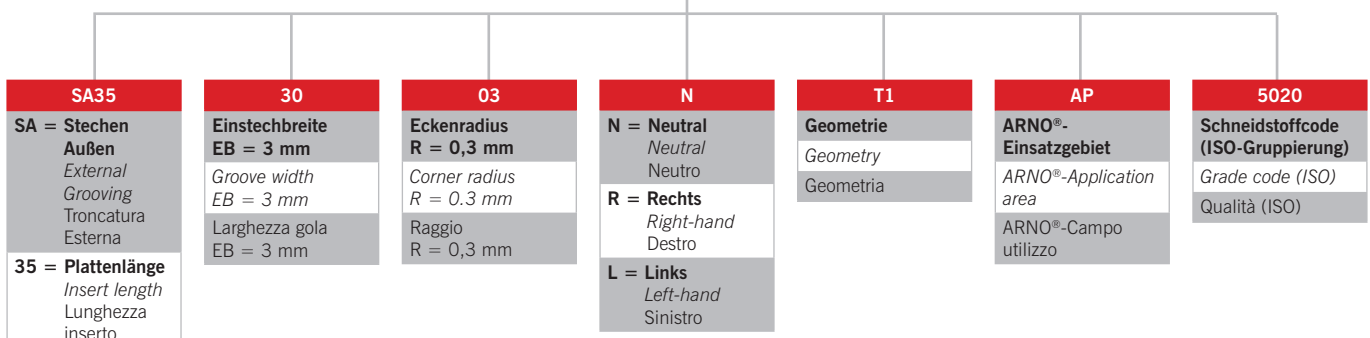

Holders for SA-Modules (MSA)
Adattatore per moduli SA (MSA)

HSA...7... – ohne ACS
HSA...7... – without ACS
HSA...7... – senza ACS

1

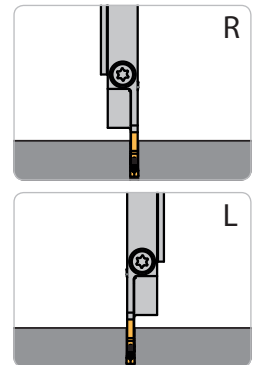
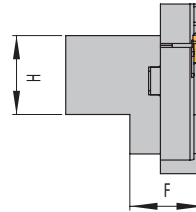
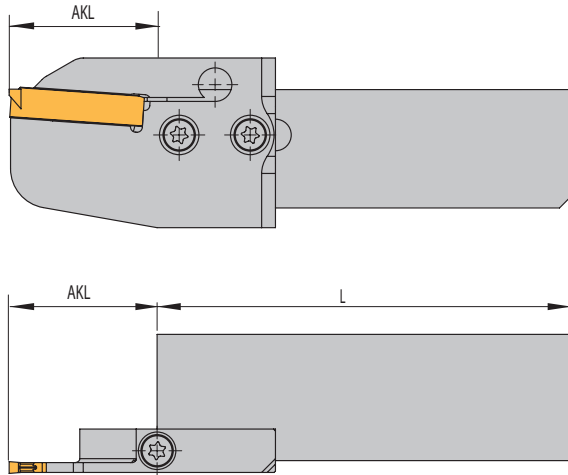

Rechter Halter und
rechtes Modul montiert
Right holder and right module shown
Adattatore destro e
modulo destro in figura

Halter für SA-Module (MSA) / Holders for SA-Modules (MSA) / Adattatore per moduli SA (MSA)

Bezeichnung Designation Articolo	H	L	PG 37
HSA 72032L	20	105	●
HSA 72032R	20	105	●
HSA-72536L	25	120	●
HSA-72536R	25	120	●

Hinweis: Halter HSA...7... werden mit Schraube und Schlüssel geliefert, jedoch ohne Modul.

Remark: Holders HSA-7... are supplied with screw and key, but without modules.

Nota: Adattatori HSA-7 sono forniti con viti e chiave, ma senza modulo.

Passende Module finden Sie ab Seite 122.

KMH-Werkzeughalter (VDI) finden Sie auf den Seiten 458 bis 477.

Suitable modules can be found starting on page 122.

KMH holders (VDI) can be found on pages 458 to 477

Per moduli compatibili vedere de pagina 122.

Adattatori KMH (VDI) vedere pagine 458 a 477.

Modul Designation Articolo	AKL	F
MSA-...-32	22,0	19,0
MSA-...-44	27,0	
MSA-...-52	37,5	
MSA-...-65	37,5	
MSA-...-80	45,0	
MSA-...-105	58,0	
MSA-...-125	68,0	
MSA-...-140	75,5	

Holder for SA-Modules (MSA)
Adattatore per moduli SA (MSA)

HSA...7... – mit ACS
HSA...7... – with ACS
HSA...7... – con ACS

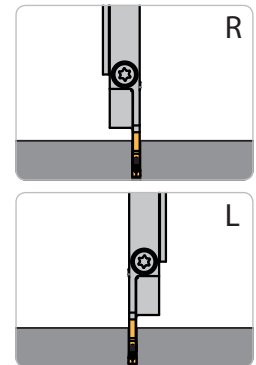
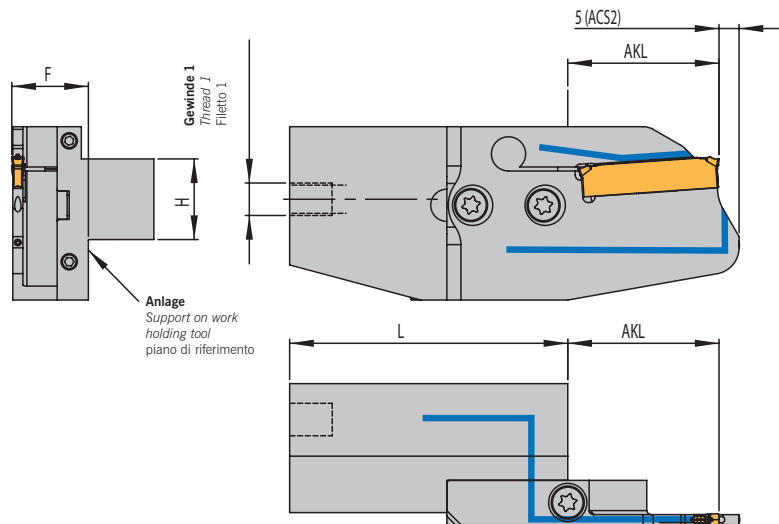

Linker Halter und linkes Modul montiert
Left holder and left module shown
Adattatore sinistra e modulo sinistra in figura

1

Halter für SA-Module (MSA) / Holder for SA-Modules (MSA) / Adattatore per moduli SA (MSA)

mit Innenkühlung ACS von hinten / with internal coolant (ACS) from the back / con adduzione interna (ACS) posteriore

Bezeichnung Designation Articolo	H	L	Gewinde 1 Thread 1 Filetto 1	PG 37
HSA-71629L-ACS-H1	16	54	M8 x 1	●
HSA-71629R-ACS-H1	16	54	M8 x 1	●
HSA-72032L-ACS-H1	20	69	M8 x 1	●
HSA-72032R-ACS-H1	20	69	M8 x 1	●
HSA-72536L-ACS-H1	25	84	M8 x 1	●
HSA-72536R-ACS-H1	25	84	M8 x 1	●
HSA-71629L-ACS-H2	16	54	G1/8"	●
HSA-71629R-ACS-H2	16	54	G1/8"	●
HSA-72032L-ACS-H2	20	69	G1/8"	●
HSA-72032R-ACS-H2	20	69	G1/8"	●
HSA-72536L-ACS-H2	25	84	G1/8"	●
HSA-72536R-ACS-H2	25	84	G1/8"	●
HSA-71629L-ACS-H3	16	54	G1/4"	●
HSA-71629R-ACS-H3	16	54	G1/4"	●
HSA-72032L-ACS-H3	20	69	G1/4"	●
HSA-72032R-ACS-H3	20	69	G1/4"	●
HSA-72536L-ACS-H3	25	84	G1/4"	●
HSA-72536R-ACS-H3	25	84	G1/4"	●

Modul Designation Articolo	AKL	F
MSA-...-32-ACS	22,0	19,0
MSA-...-44-ACS	27,0	
MSA-...-52-ACS	37,5	
MSA-...-65-ACS	37,5	
MSA-...-69-ACS	39,5	
MSA-...-80-ACS	45,0	
MSA-...-90-ACS	50,0	
MSA-...-105-ACS	58,0	

Hinweis: Halter HSA...7... werden mit Schraube und Schlüssel geliefert, jedoch ohne Modul.

Remark: Holders HSA-7... are supplied with screw and key, but without modules.

Nota: Adattatori HSA-7 sono forniti con viti e chiave, ma senza modulo.

Passende Module finden Sie ab Seite 122.

KMH-Werkzeughalter (VDI) finden Sie auf den Seiten 458 bis 477.

Suitable modules can be found starting on page 122.

KMH holders (VDI) can be found on pages 458 to 477

Per moduli compatibili vedere da pagina 122.

Adattatori KMH (VDI) vedere pagine 458 a 477.

Kühlmittelanschlüsse finden Sie auf Seite 74

Coolant supply can be found on page 74

Raccordo vedere pagina 74



Diese Monoblockhalter bekommen Sie mit Ihren spezifischen Kühlan schlüssen. Ein Anfrageblatt hierzu finden Sie auf Seite 118 oder im Internet unter: www.arno.de/service/downloads

The coolant inlet can be supplied to your specification, please complete enquiry sheet on page 118 or download this from: www.arno.de/service/downloads

Questi corpi utensile sono fornibili con specifiche connessioni del refrigerante, Vedere modulo richiesta a Pag. 118 o download del modulo da: www.arno.de/service/downloads

Halter HSA...7...ACS mit Innenkühlung ACS von hinten



1

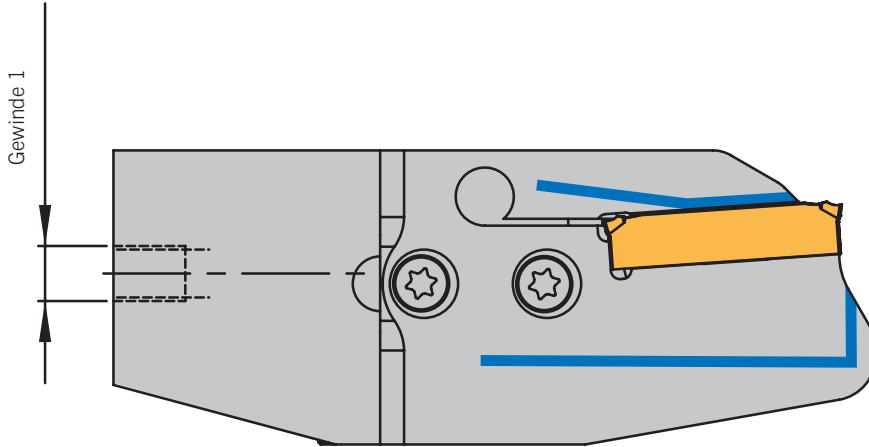

Diese Halter fertigen wir Ihnen zum Preis des Standardwerkzeuges.

Aus Halter

Gewinde 1



Download dieses Formulares unter: www.arno.de/service/downloads

Holder HSA-7 with internal coolant ACS from the back



1

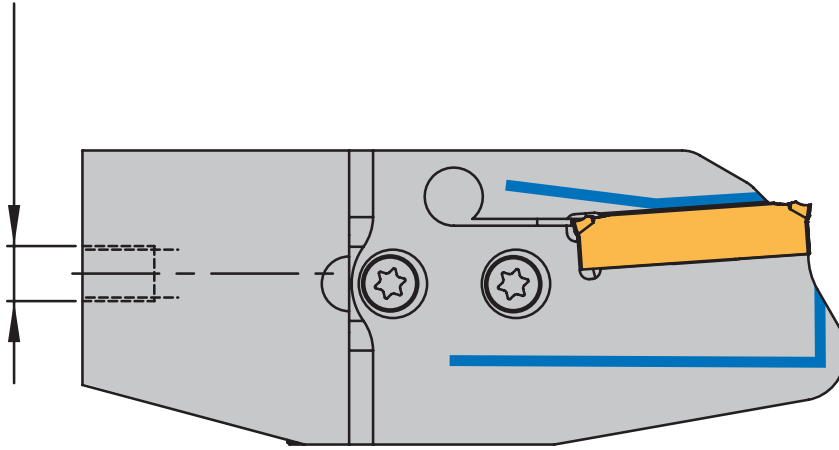

This tool we produce to the price of the standard tool.

From holder

Thread 1



Download this form from: www.arno.de/service/downloads

Adattatore HSA...7... per moduli MSA con refrigerazione interna posteriore

ARNO® SpecialDesign

1

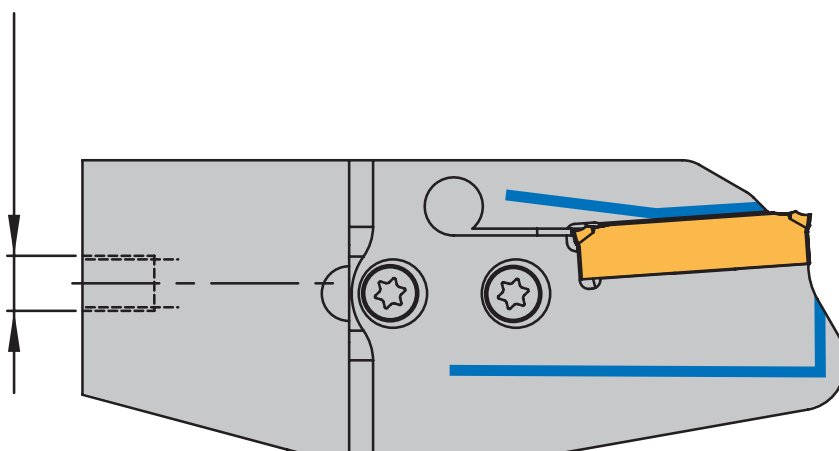

La modificazione del filetto posteriore per il attacco ACS del adattatore HSA ...7... é incluso nel prezzo standard

Ricavare da utensile

Filetto 1



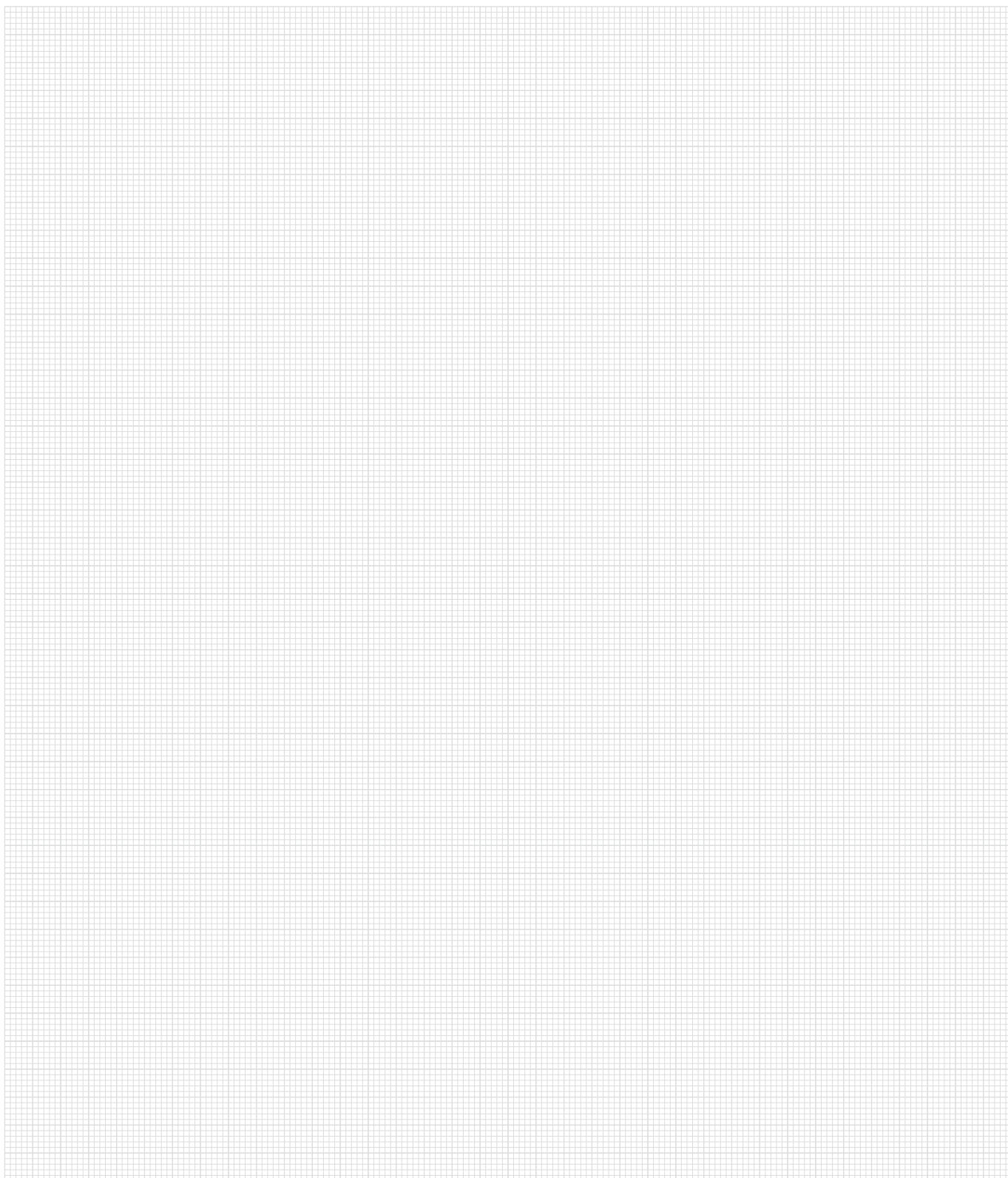

Weitere Informationen finden Sie unter:

For more information see:

Per maggiori informazioni visita il sito:

www.arno.de

MSA

Modul für einseitige Schneideinsätze / *Module for single-sided inserts* / Modulo per inserti monolaterali

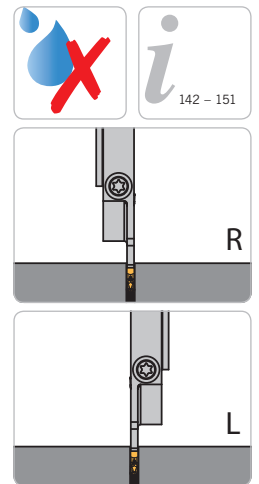

1

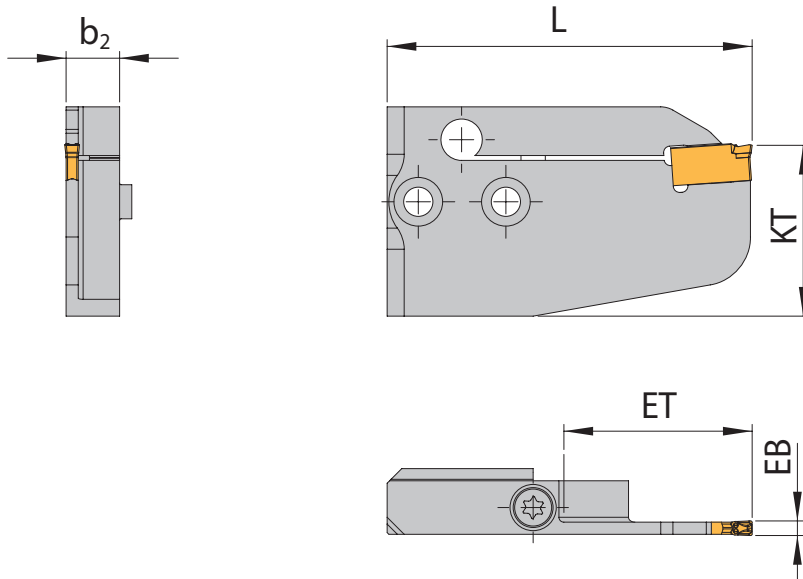

Linke Ausführung abgebildet
Left-hand execution shown
Versione sinistra in figura

Trägerwerkzeuge / *Holder* / Utensili

Bezeichnung Designation Articolo	EB	ET	D _{max}	D _R	b ₂	L	KT	PG 37	Schneideinsatz Insert Inserto
MSA-SL/R-SA1703-80	3	40,0	80	80	11	75	35	●	SA 17-30...
MSA-SL-SA1703-105	3	52,5	105	105	11	88	35	●	SA 17-30...
MSA-SL/R-SA1704-80	4	40,0	80	80	11	75	35	●	SA 17-40...
MSA-SL/R-SA1704-105	4	52,5	105	105	11	88	35	●	SA 17-40...

D_{max} = Maximaler Durchmesser bei Vollmaterial, D_R = Maximaler Stechdurchmesser bei Rohren

D_{max} = Maximum diameter in solid, D_R = Maximum diameter for tube material

D_{max} = Diametro massimo lavorazione dal pieno, D_R = Diametro massimo da tubo

Bei Modulen für Abstech- ϕ ab 105mm muss ein Drehmomentschlüssel verwendet werden. Anzugsmoment 3Nm.

When using part-off modules from 105mm diameter we recommend using a torque at torque setting of 3Nm

Con l'utilizzo di moduli di troncatura fino a 105mm, è necessario l'utilizzo di chiave dinamometrica tratta a 3Nm

Die Module passen auf alle Grundhalter in Standardausführung, auf die eine Unterstützplatte montiert werden kann.

The modules suit all the NC-holders in the standard design where a NC-module can be located

I Moduli sono associabili a tutti gli steli standard NC di scanalatura modulare ARNO.

Ersatzteile / *Spare Parts* / Ricambi

Trägerwerkzeug Holder Utensile	Schraube Screw Vite	Schlüssel Key Chiave
MSA-S R/L..	SA5T	T5220-IP

MSA

Modul für zweiseitige Schneideinsätze / Module for double sided inserts / Modulo per inserti bilaterale

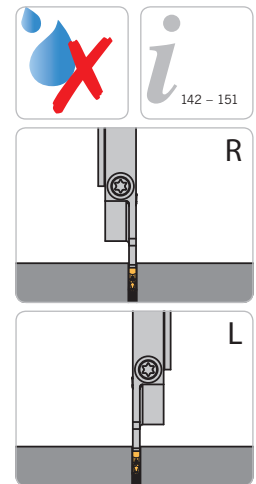
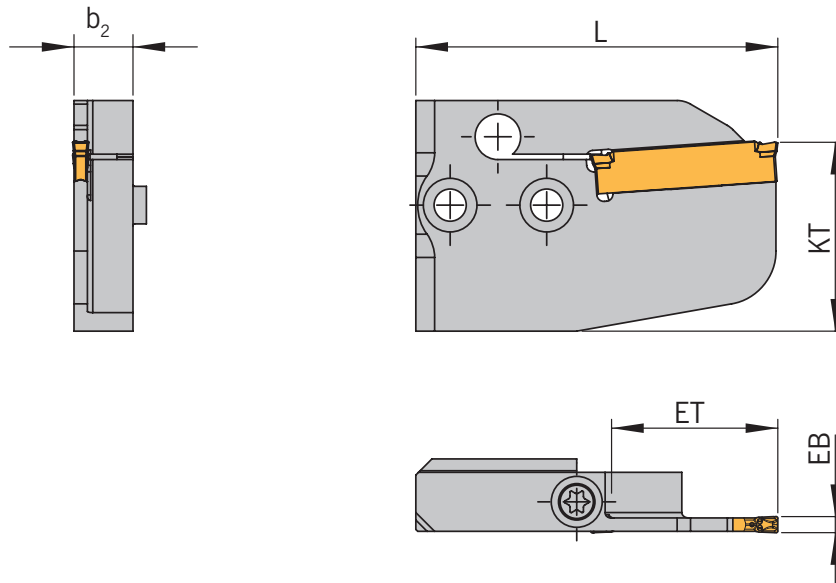

1

Linke Ausführung abgebildet
Left-hand execution shown
Versione sinistra in figura

Trägerwerkzeuge / Holders / Utensili

Bezeichnung Designation Articolo	EB	ET	D _{max}	D _R	b ₂	L	KT	PG 37	Schneideinsatz Insert Inserto
MSA-SL/R-SA24015-32	1,5	16,0	32	48	11	52,0	35,0	●	SA 24-15...
MSA-SL/R-SA24015-44	1,5	22,0	44	61	11	57,0	35,0	●	SA 24-15...
MSA-SL/R-SA2402-32	2,0	16,0	32	48	11	52,0	35,0	●	SA 24-20...
MSA-SL/R-SA2402-44	2,0	22,0	44	61	11	57,0	35,0	●	SA 24-20...
MSA-SL/R-SA2403-32	3,0	16,0	32	48	11	52,0	35,0	●	SA 24-30...
MSA-SL/R-SA2403-44	3,0	22,0	44	61	11	57,0	35,0	●	SA 24-30...
MSA-SL/R-SA2404-44	4,0	22,0	44	61	11	57,0	35,0	●	SA 24-40...
MSA-SL/R-SA3502-52	2,0	26,0	52	68	11	67,5	35,0	●	SA 35-20...
MSA-SL/R-SA3502-65	2,0	32,5	65	80	11	67,5	35,0	●	SA 35-20...
MSA-SL/R-SA3502-105	2,0	52,5	105	105	11	88,0	35,0	●	SA 35-20...
MSA-SL/R-SA3503-52	3,0	26,0	52	68	11	67,5	35,0	●	SA 35-30...
MSA-SL/R-SA3503-65	3,0	32,5	65	80	11	67,5	35,0	●	SA 35-30...
MSA-SL/R-SA3503-105	3,0	52,5	105	105	11	88,0	35,0	●	SA 35-30...
MSA-SL/R-SA3503-125	3,0	62,5	125	125	11	97,5	48,5	●	SA 35-30...
MSA-SR-SA3503-140	3,0	70,0	140	140	11	105,5	48,5	●	SA 35-30...
MSA-SL/R-SA3504-52	4,0	26,0	52	68	11	67,5	35,0	●	SA 35-40...
MSA-SL/R-SA3504-65	4,0	32,5	65	80	11	67,5	35,0	●	SA 35-40...
MSA-SL/R-SA3504-105	4,0	52,5	105	105	11	88,0	35,0	●	SA 35-40...

D_{max} = Maximaler Durchmesser bei Vollmaterial, D_R = Maximaler Stechdurchmesser bei Rohren
 D_{max} = Maximum diameter in solid, D_R = Maximum diameter for tube material
 D_{max} = Diametro massimo lavorazione dal pieno, D_R = Diametro massimo da tubo

Bei Modulen für Abstech- ϕ ab 105mm muss ein Drehmomentschlüssel verwendet werden. Anzugsmoment 3Nm.
 When using part-off modules from 105mm diameter we recommend using a torque at torque setting of 3Nm
 Con l'utilizzo di moduli di troncatura fino a 105mm, è necessario l'utilizzo di chiave dinamometrica trita a 3Nm

Die Module passen auf alle Grundhalter in Standardausführung, auf die eine Unterstützplatte montiert werden kann.
 The modules suit all the NC-holders in the standard design where a NC-module can be located
 I Moduli sono associabili a tutti gli steli standard NC di scanalatura modulare ARNO.

Ersatzteile / Spare Parts / Ricambi

Trägerwerkzeug Holder Utensile	Schraube Screw Vite	Schlüssel Key Chiave
MSA-S R/L..	SA5T	T5220-IP

MSA-ACS1

Modul mit Innenkühlung – ACS1

Module with through tool coolant - ACS1

Modulo con adduzione interna - ACS1

1

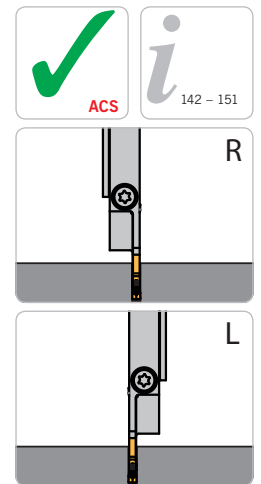
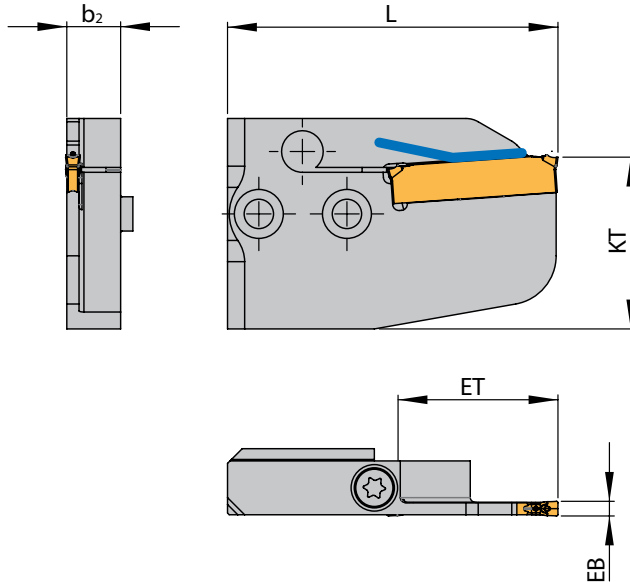

Linke Ausführung abgebildet
Left-hand execution shown
Versione sinistra in figura



Trägerwerkzeuge / Holders / Utensili

Bezeichnung Designation Articolo	EB	ET	D _{max}	D _R	b ₂	L	KT	PG 37	Schneideinsatz Insert Inserto
MSA-SL/R-SA2402-44-ACS1	2	22,0	44	61	11	57,0	35	●	SA 24-20...
MSA-SL/R-SA2403-44-ACS1	3	22,0	44	61	11	57,0	35	●	SA 24-30...
MSA-SL/R-SA3502-65-ACS1	2	32,5	65	80	11	67,5	35	●	SA 35-20...
MSA-SL/R-SA3502-90-ACS1	2	45,0	90	90	11	80,0	35	●	SA 35-20...
MSA-SL/R-SA3503-65-ACS1	3	32,5	65	80	11	67,5	35	●	SA 35-30...
MSA-SL/R-SA3503-105-ACS1	3	52,5	105	105	11	88,0	35	●	SA 35-30...
MSA-SL-SA3504-105-ACS1	4	52,5	105	105	11	88,0	35	●	SA 35-40...
MSA-SL-SA3506-65-ACS1	6	32,5	65	80	12	67,5	35	●	SA 35-60...
MSA-SL-SA3506-105-ACS1	6	52,5	105	105	12	88,0	35	●	SA 35-60...

D_{max} = Maximaler Durchmesser bei Vollmaterial, D_R = Maximaler Stechdurchmesser bei Rohren

D_{max} = Maximum diameter in solid, D_R = Maximum diameter for tube material

D_{max} = Diametro massimo lavorazione dal pieno, D_R = Diametro massimo da tubo

Bei Modulen für Abstech- ϕ ab 105mm muss ein Drehmomentschlüssel verwendet werden. Anzugsmoment 3Nm.

When using part-off modules from 105mm diameter we recommend using a torque at torque setting of 3NM

Con l'utilizzo di moduli di troncatura fino a 105mm, è necessario l'utilizzo di chiave dinamometrica tratta a 3Nm

Hinweis: Passende Direktaufnahmen finden Sie in Kapitel 9.

Remark: Suitable flange mounted holders with VDI can be found in chapter 9.

Nota: Per combinazioni attacco VDI vedere capitolo 9.

Ersatzteile / Spare Parts / Ricambi

Trägerwerkzeug Holder Utensile	Schraube Screw Vite	Schlüssel Key Chiave
MSA-S R/L..	SA5T	T5220-IP

MSA-ACS2

Modul mit Innenkühlung – ACS2

Module with through tool coolant – ACS2

Modulo con adduzione interna – ACS2

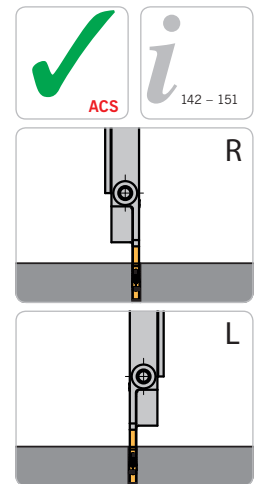
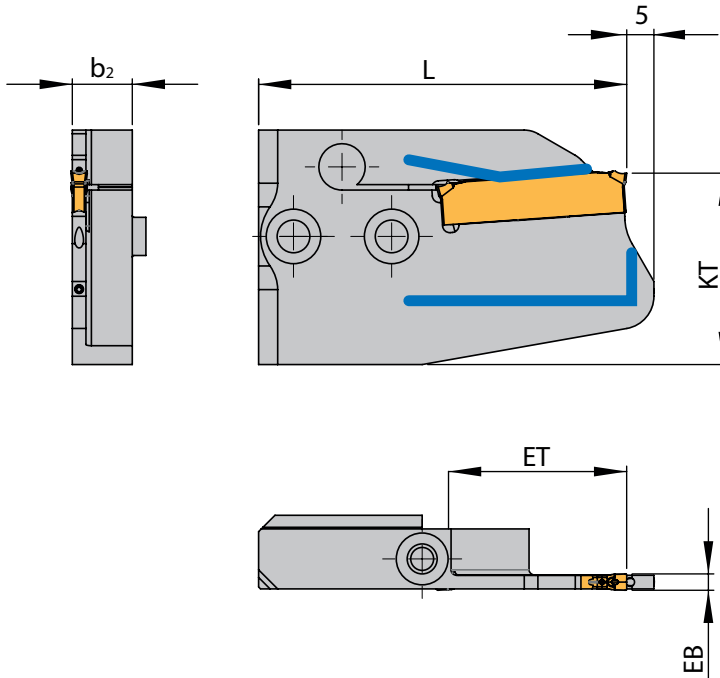

1

Linke Ausführung abgebildet
Left-hand execution shown
Versione sinistra in figura



Trägerwerkzeuge / Holders / Utensili

Bezeichnung Designation Articolo	EB	ET	D _{max}	D _R	b ₂	L	KT	PG 37	Schneideinsatz Insert Inserto
MSA-SL/R-SA2402-32-ACS2	2	16,0	32	48	11	52,0	35	●	SA 24-20...
MSA-SL/R-SA2402-44-ACS2	2	22,0	44	61	11	57,0	35	●	SA24-20..
MSA-SL/R-SA2403-32-ACS2	3	16,0	32	48	11	52,0	35	●	SA24-30..
MSA-SL/R-SA2403-44-ACS2	3	22,0	44	61	11	57,0	35	●	SA24-30..
MSA-SL/R-SA3503-52-ACS2	3	26,0	52	68	11	67,5	35	●	SA35-30..
MSA-SL/R-SA3503-65-ACS2	3	32,5	65	80	11	67,5	35	●	SA35-30..
MSA-SL/R-SA3503-69-ACS2	3	34,5	69	80	11	69,5	35	●	SA35-30..
MSA-SL/R-SA3503-80-ACS2	3	40,0	80	80	11	75,0	35	●	SA35-30..
MSA-SL/R-SA3503-90-ACS2	3	45,0	90	90	11	80,0	35	●	SA 35-30...
MSA-SL/R-SA3503-105-ACS2	3	52,5	105	105	11	88,0	35	●	SA35-30..
MSA-SL/R-SA3504-65-ACS2	4	32,5	65	80	11	67,5	35	●	SA35-40..
MSA-SL/R-SA3504-105-ACS2	4	52,5	105	105	11	88,0	35	●	SA35-40..

D_{max} = Maximaler Durchmesser bei Vollmaterial, D_R = Maximaler Stechdurchmesser bei Rohren
 D_{max} = Maximum diameter in solid, D_R = Maximum diameter for tube material
 D_{max} = Diametro massimo lavorazione dal pieno, D_R = Diametro massimo da tubo
Bei Modulen für Abstech- ϕ ab 105mm muss ein Drehmomentschlüssel verwendet werden. Anzugsmoment 3Nm.
 When using part-off modules from 105mm diameter we recommend using a torque at torque setting of 3Nm
 Con l'utilizzo di moduli di troncatura fino a 105mm, è necessario l'utilizzo di chiave dinamometrica tratta a 3Nm

Hinweis: Passende Direktaufnahmen finden Sie in Kapitel 9.
 Remark: Suitable flange mounted holders with VDI can be found in chapter 9.
 Nota: Per combinazioni attacco VDI vedere capitolo 9.

Ersatzteile / Spare Parts / Ricambi

Trägerwerkzeug Holder Utensile	Schraube Screw Vite	Schlüssel Key Chiave
MSA-S R/L..	SA5T	T5220-IP

MSA-IN

Module in neutraler Ausführung / Modules in neutral design / Modulo neutro di taglio

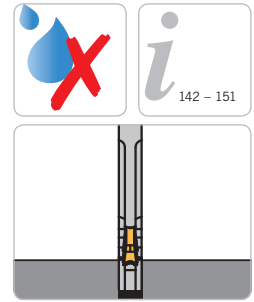

1

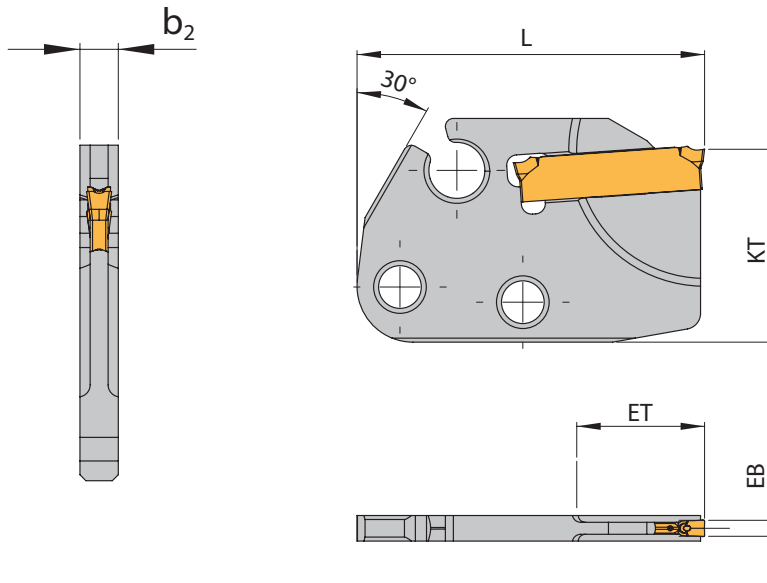

Trägerwerkzeuge / Holders / Utensili

Bezeichnung Designation Articolo	EB	ET	D _{max}	b ₂	L	KT	PG 37	Schneideinsatz Insert Inserto
MSA-IN-SA16015-L43,5-12	1,5	6	12	3,2	43,5	24	●	SA 16-15...
MSA-IN-SA16015-L43,5-16	1,5	8	16	3,2	43,5	24	●	SA 16-15...
MSA-IN-SA1602-20	2,0	10	20	3,2	35,5	24	●	SA 16-20...
MSA-IN-SA1602-26	2,0	13	26	3,2	35,5	24	●	SA 16-20...
MSA-IN-SA24015-20	1,5	10	20	3,2	43,5	24	●	SA 24-15...
MSA-IN-SA24015-32	1,5	16	32	3,2	43,5	24	●	SA 24-15...
MSA-IN-SA2402-20	2,0	10	20	3,2	43,5	24	●	SA 24-20...
MSA-IN-SA2402-26	2,0	13	26	3,2	43,5	24	●	SA 24-20...
MSA-IN-SA2402-32	2,0	16	32	3,2	43,5	24	●	SA 24-20...
MSA-IN-SA2402-L54-26	2,0	13	26	3,2	54,0	24	●	SA 24-20...
MSA-IN-SA2403-32	3,0	16	32	3,2	43,5	24	●	SA 24-30...
MSA-IN-SA3503-52	3,0	26	52	3,2	54,5	24	●	SA 35-30...

D_{max} = Maximaler Durchmesser bei Vollmaterial

D_{max} = Maximum diameter in solid

D_{max} = Diametro massimo lavorazione dal pieno

Neutrale Module können beidseitig montiert werden.

Neutral modules can be mounted both sides.

Moduli con montaggio Neutro possono essere montati su entrambe i lati.

Module werden ohne Schrauben ausgeliefert.

Holders are not supplied with screws.

Moduli sono forniti senza viti di montaggio.

Ersatzteile / Spare Parts / Ricambi

Trägerwerkzeug Holder Utensile	Schraube Screw Vite	Schlüssel Key Chiave
MSA-I ..	2 x AS 0049 / 1 x AS 0050*	T5220-IP

* Alternativ AS 0050D (doppelseitig IP20)

* Alternative AS 0050D (Double-sided IP20)

* Alternativa AS 0050D (doppio lato IP20)

MSA-IL/R...ACS1

Modul mit Innenkühlung – ACS1

Module with through tool coolant - ACS1

Modulo con adduzione interna - ACS1

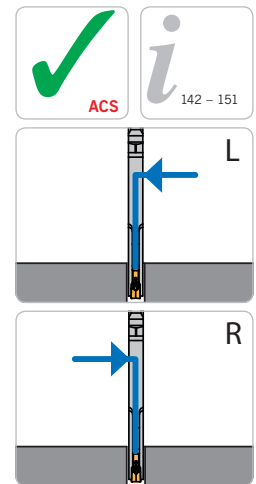
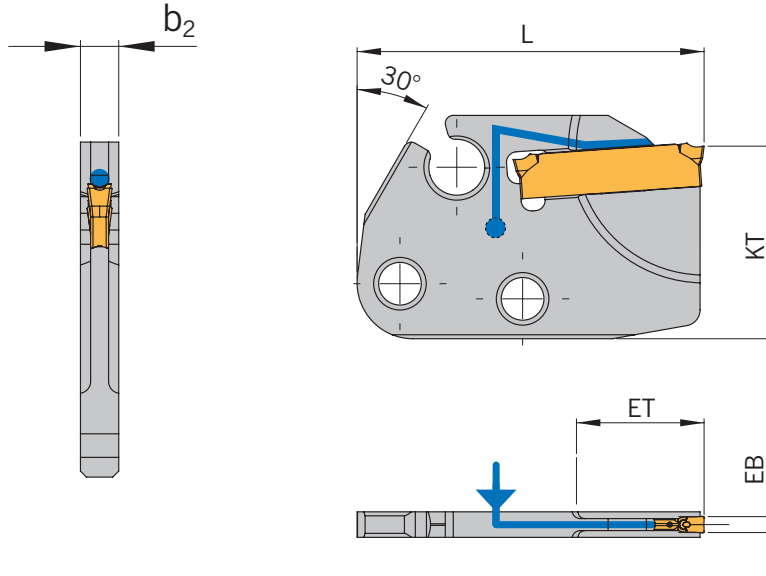

1

Linke Ausführung abgebildet
Left-hand execution shown
Versione sinistra in figura



Trägerwerkzeuge / Holders / Utensili

Bezeichnung Designation Articolo	EB	ET	D _{max}	b ₂	L	KT	PG 37	Schneideinsatz Insert Inserto
MSA-IL/R-SA1602-L37-20-ACS1	2	10	20	3,2	37,0	24	●	SA 16-20...
MSA-IL/R-SA1602-L41-20-ACS1	2	10	20	3,2	41,0	24	●	SA 16-20...
MSA-IL/R-SA1602-L43,5-26-ACS1	2	13	26	3,2	43,5	24	●	SA 16-20...
MSA-IL/R-SA1602-L45,5-22-ACS1	2	11	22	3,2	45,5	24	●	SA 16-20...
MSA-IL/R-SA2402-L44-46-ACS1	2	23	46	3,2	44,0	24	●	SA 24-20...
MSA-IL/R-SA2402-L45,5-32-ACS1	2	16	32	3,2	45,5	24	●	SA 24-20...
MSA-IL-SA2402-L48,5-20-ACS1 ^(N)	2	10	20	3,2	48,5	24	●	SA 24-20...
MSA-IL/R-SA2402-L48,5-42-ACS1	2	21	42	3,2	48,5	24	●	SA 24-20...
MSA-IL-SA2402-L56-32-ACS1 ^(N)	2	16	32	3,2	56,0	24	●	SA 24-20...
MSA-IL/R-SA2403-L45,5-32-ACS1	3	16	32	3,2	45,5	24	●	SA 24-30...
MSA-IL/R-SA2403-L48,5-42-ACS1	3	21	42	3,2	48,5	24	●	SA 24-30...
MSA-IL/R-SA3502-L55-52-ACS1	2	26	52	3,2	55,0	24	●	SA 35-20...
MSA-IL/R-SA3503-L55-52-ACS1	3	26	52	3,2	55,0	24	●	SA 35-30...

D_{max} = Maximaler Durchmesser bei Vollmaterial

D_{max} = Maximum diameter in solid

D_{max} = Diametro massimo lavorazione dal pieno

Hinweis: Passende Direktaufnahmen Tornos / Göltenbott und Index finden Sie in Kapitel 9.

Remark: Suitable flange mounted holders Tornos / Göltenbott and Index can be found in chapter 9.

Nota: Per combinazioni attacco VDI Tornos / Göltenbott e Index vedere capitolo 9.

Ersatzteile / Spare Parts / Ricambi

Trägerwerkzeug Holder Utensile	Schraube Screw Vite	Schlüssel Key Chiave
MSA-I ..	2 x AS 0049 / 1 x AS 0050*	T5220-IP

* Alternativ AS 0050D (doppelseitig IP20)

* Alternative AS 0050D (Double-sided IP20)

* Alternativa AS 0050D (doppio lato IP20)

MSA-ILL/IRR-ACS1

Modul mit Innenkühlung – ACS1

Module with through tool coolant - ACS1

Modulo con adduzione interna - ACS1

1

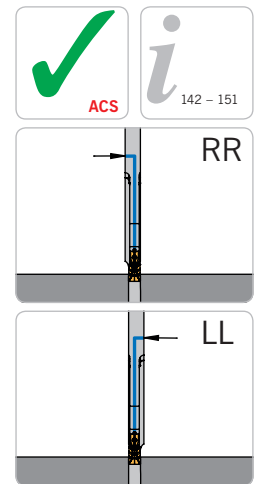
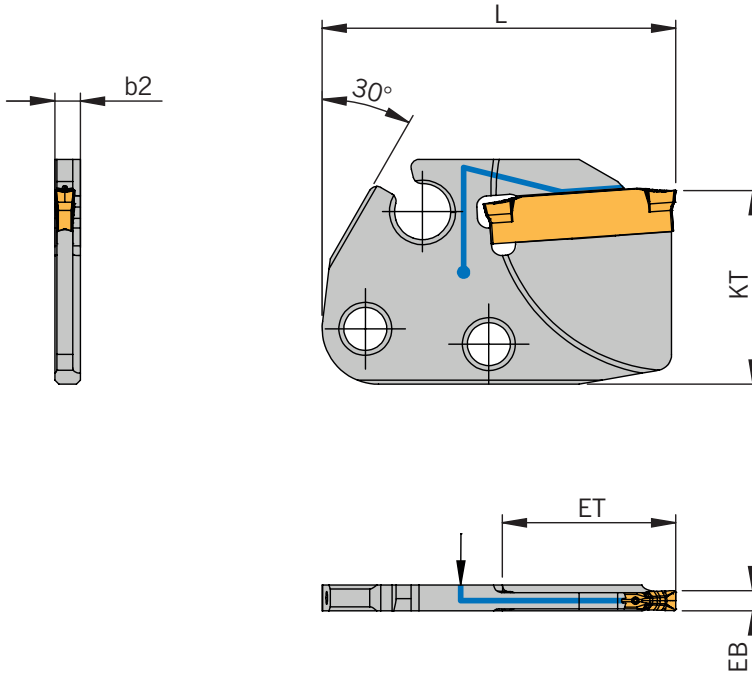

Linke Ausführung abgebildet
Left-hand execution shown
Versione sinistra in figura

N NEU/NEW/
NUOVO

Trägerwerkzeuge / Holders / Utensili

Bezeichnung Designation Articolo	EB	ET	D _{max}	b ₂	L	KT	PG 37	Schneideinsatz Insert Inserto
MSA-ILL-SA1602-L45,5-22-ACS1 N	2,0	11	22	3,2	45,5	24	●	SA 16-20...
MSA-ILL-SA24025-L44-44-ACS1 N	2,5	22	44	3,2	44,0	24	●	SA24-25...
MSA-IRR-SA24025-L44-44-ACS1 N	2,5	22	44	3,2	44,0	24	●	SA24-25...
MSA-ILL-SA24025-L51-46-ACS1 N	2,5	23	46	3,2	51,0	24	●	SA24-25...

D_{max} = Maximaler Durchmesser bei Vollmaterial

D_{max} = Maximum diameter in solid

D_{max} = Diametro massimo lavorazione dal pieno

Hinweis: Passende Direktaufnahmen Tornos / Göltenbodt und Index finden Sie in Kapitel 9.

Remark: Suitable flange mounted holders Tornos / Göltenbodt and Index can be found in chapter 9.

Nota: Per combinazioni attacco VDI Tornos / Göltenbodt e Index vedere capitolo 9.

Ersatzteile / Spare Parts / Ricambi

Trägerwerkzeug Holder Utensile	Schraube Screw Vite	Schlüssel Key Chiave
MSA-I RR/LL..	2 x AS 0049 / 1 x AS 0050*	T5220-IP

* Alternativ AS 0050D (doppelseitig IP20)

* Alternative AS 0050D (Double-sided IP20)

* Alternativa AS 0050D (doppio lato IP20)

**F1**

Sehr schneidfreudige Geometrie mit geringen Schnittkräften

- Für alle Werkstoffe im niedrigen bis mittleren Festigkeitsbereich
- Geringe Aufbauschnedenbildung
- Geeignet für dünnwandige Werkstücke

F1

Very soft cutting geometry

- *For low to medium strength materials with low built-up edge tendency*
- *Suitable for thin-walled components*

F1

La geometria per basse forze di taglio

- Per tutti materiali con durezza medio bassa
- Poca formazione di bava
- Adatto per pezzi sottili

**T1**

Sehr gute Spankontrolle und Einschnürung

- Für Stahl und Rostfreibearbeitung
- Universell einsetzbar – auch bei dünnwandigen Bauteilen

T1

Very good swarf control and formation

- *For steel and stainless steel*
- *Universal geometry machining, for thin-walled components*

T1

La geometria dall'ottimo controllo truciolo

- Per acciaio e materiali inossidabili
- Utilizzo universale, anche per pezzi sottili

**S1**

Weichschneidende Geometrie

- Spezielle Geometrie für rostfreie Stähle
- „Problemlöser“ bei der Stahlzerspanung

S1

Soft cutting geometry

- *Especially for stainless steel*
- *Problem solver for steel machining*

S1

Geometria di taglio dolce

- Geometria specifica per acciai inossidabili
- Il risolutore dei problemi nella lavorazione di acciaio

**M1**

Geometrie mit schmaler Negativfase

- Für Werkstoffe mit mittlerer bis hoher Festigkeit
- Universell einsetzbar bei Stahl (Rostfrei und Guss)
- Erste Wahl bei stabilen Verhältnissen

M1

Geometry with small negative chamfer

- *For medium to high strength materials*
- *Suitable for all steels (stainless and cast)*
- *First choice where cutting conditions are solid*

M1

La geometria robusta

- Per materiali con durezza medio alta
- Utilizzo universale per acciaio (anche inossidabile e ghisa)
- Prima scelta per condizioni stabili

**ALU**

Geometrie mit scharfer Schneide

- Erste Wahl für Aluminium und NE-Metalle
- Umseitig geschliffener Schneideinsatz
- Hochpositive Geometrie
- Polierte Spanflächen

ALU

Geometry with a sharp edge

- *First choice for aluminium and non-ferrous materials*
- *Periphery ground insert*
- *High positive design*
- *Polished chip breakers*

ALU

Geometria super positiva rettificata

- Prima scelta per Alluminio e materiali non ferrosi
- Inserto rettificato
- Spoglia di taglio molto positiva
- Vano truciolo lappato

Beschichtet / Coated / Rivestito

AM5040

PVD-beschichtete Hartmetallsorte

Eine zähe, universell einsetzbare Sorte für niedrige und mittlere Schnittgeschwindigkeiten. Hauptanwendungsbereich für rostfreie Stähle sowie für die Stahlbearbeitung. Gute Prozesssicherheit sowie beständig gegen Schneidkantenabrüche.

PVD coated carbide

A tough but universal grade for low to medium cutting speeds. The main application area being stainless steel and steel.

Metallo duro rivestito PVD

Qualità universale per velocità medio basse. Campo di applicazione principale acciai inossidabili, superleghe, acciai legati. Notevole robustezza e resistenza alla scheggiatura.

AP2220

CVD-Mehrlagenbeschichtung

Sorte mit ausgezeichneter Kombination von hoher Verschleißfestigkeit und guter Schneidkantenstabilität. Hauptanwendung für legierte Stahlwerkstoffe und Gusswerkstoffe. Nebenanwendung für rostfreien Stahl. Unter stabilen Bearbeitungsbedingungen bei mittleren bis hohen Schnittgeschwindigkeiten.

CVD-multilayer coating

Grade with excellent combination of wear resistance and cutting edge stability. Main application area is alloy steel and cast materials. But under stable conditions also suitable for stainless steel at medium to high cutting speeds.

Rivestimento multistrato CVD

Ottima resistenza all'usura e stabilità dei taglienti. Adatto per leghe d'acciaio e ghisa. Utilizzo secondario per acciaio inossidabile. Ideale in condizioni di lavoro stabili e elevate velocità di taglio.

AP2240

CVD-beschichtete Hartmetallsorte

Die AP2240 überzeugt mit großer Zähigkeit und hoher Wärmebeständigkeit und erreicht dadurch außerordentliche Standzeiten. Durch die stabilen Schneidkanten wird die Prozesssicherheit deutlich höher. Hauptanwendung dieser Sorte liegt in der Stahl- und Gussbearbeitung. In der Nebenanwendung ist sie auch für rostfreie Stähle zu empfehlen.

CVD coated carbide grade

The AP2240 provides more toughness and heat resistance and thereby even more tool life. The strong cutting edge improves the process reliability. Main application area is steel and cast iron machining. Can also be used for stainless steel machining.

Grado rivestito CVD

La qualità AP2240 offre maggiore tenacità e resistenza alle temperature incrementando la vita inserto. Il robusto tagliente incrementa l'affidabilità di lavorazione. Campo principale di impiego su acciaio e ghise acciaiose. Idoneo anche per alcuni acciai inox.

AP5020

PVD-beschichtete Hartmetallsorte

Eine sehr universell einsetzbare Sorte für niedrige und mittlere Schnittgeschwindigkeiten. Hauptanwendungsbereich für Stahl. Als Nebenanwendung geeignet für die Bearbeitung rostfreier Stähle und für das Ein- und Abstechen hochwarmfester Werkstoffe und NE-Metalle.

PVD coated carbide

A universal grade for low to medium cutting speed. Main application areas are steel and stainless steel, but also suitable for part-off and grooving of high temperature alloys and non-ferrous materials.

Metallo duro rivestito PVD

Qualità universale per velocità di taglio medie. Adatto principalmente per acciaio e secondariamente per acciaio inossidabile. Utilizzo secondario anche per metalli non ferrosi e refrattari.

AP5030

PVD-beschichtete Hartmetallsorte

Eine universell einsetzbare Sorte im Bereich P30-P35 für die Einstech- und Abstechbearbeitungen. Hauptanwendungsbereich für die Stahlbearbeitung, Nebenanwendung für rostfreie Stähle.

PVD coated carbide

A universal grade mainly for steel applications. The slightly tougher substrate (ISO P30-P35) makes it suitable also for stainless steel.

Metallo duro rivestito PVD

Qualità molto versatile su campo ISO P30-P35 per lavorazioni in sicurezza. Ottima per la lavorazione di acciai in condizioni non perfette di lavoro. Secondaria scelta per acciai inossidabili.

AP5820+

PVD-beschichtete Hartmetallsorte

Universelle Sorte mit hoher Verschleißfestigkeit. Hauptanwendungsbereich in der Stahlzerspannung sowie für hochwarmfeste Werkstoffe wie zum Beispiel Inconel. Nebenanwendung bei rostfreien Stählen. Geeignet auch für Kühlung mit Öl.

PVD coated carbide

Universal grade with high wear resistance. Main application area is steel machining, high temperature alloys such as inconel as well as stainless steel. Also suitable for coolant with oil.

Qualità di metallo duro con rivestimento PVD

Grado universale con elevata resistenza all'usura. Principali applicazioni in lavorazioni di leghe esotiche e ad alta temperatura come Inconel. Eccellente anche per acciai inossidabili. Adatto anche con refrigerante ad olio intero.

Unbeschichtet / Uncoated / Non rivestito

AN1015

Unbeschichtete Hartmetallsorte zum Schlichten und Schruppen von Aluminiumlegierungen und bei NE-Metallen in Verbindung mit geschliffenen Schneidkanten. Zur Reduzierung der Aufbauschniedenbildung ist die Spanfläche hochglanzpoliert.

Uncoated carbide grade which in connection with a ground cutting edge is for finishing and roughing of aluminium alloys and non-ferrous materials. In order to reduce build up edge problems the insert is also highly polished.

Grado di metallo duro micrograna per tutte le lavorazioni di materiali non ferrosi e Alluminio. Tagliente rettificato super positivo e spoglia lappata per ridurre tagliente di riporto.

AN8020

Polykristalliner Diamant mit Hartmetallunterlage, Mittelkorn, gute Schneidenschärfe und geringer Schnittdruck bei engen Toleranzen. Gute Verschleißfestigkeit und Zähigkeit. Schlichten bis Schruppen aller NE-Werkstoffe mit hoher Schnittgeschwindigkeit.

Polycrystalline, carbide reinforced diamond on medium grain carbide pad. Good cutting edge sharpness and low cutting forces allow small tolerance machining. Increased wear resistance and toughness. Finishing and general purpose machining of all non-ferrous metals at high cutting speeds.

Qualità di diamante policristallino a grana media rinforzata di carburi su base metallo duro. Buona stabilità del filo tagliente e ridotte forze di taglio assicurano esecuzioni a basse tolleranze. Incrementata resistenza all'usura e tenacità. Finitura e generiche applicazioni di metalli non ferrosi ad alte velocità di taglio.

1

Inserts
Inserti

SA16

1

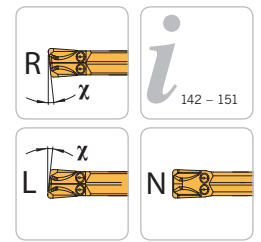
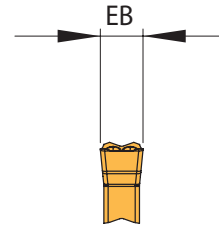
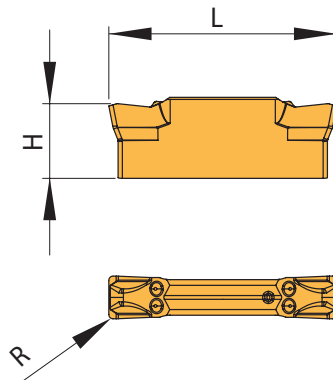

Gesinterte Ausführung / Sintered Execution / Esecuzione Sinterizzato

							PG 38		
							beschichtet coated rivestito		
Bezeichnung Designation Articolo	EB ± 0,04	H	L	R	χ	AM5040	AP2220	AP5020	
SA16-1502N-S1	1,5	5,5	16	0,2	0°			●	
SA16-2002N-F1	2,0	5,5	16	0,2	0°		●	●	
SA16-2002N-S1	2,0	5,5	16	0,2	0°	●		●	
SA16-2002N-T1	2,0	5,5	16	0,2	0°		●	●	
SA16-3003L/R-M1	3,0	5,5	16	0,3	6°		●	●	
SA16-3003L/R-S1	3,0	5,5	16	0,3	6°	●			
SA16-3003L/R-T1	3,0	5,5	16	0,3	6°			●	
SA16-3003N-M1	3,0	5,5	16	0,3	0°		●	●	
SA16-3003N-S1	3,0	5,5	16	0,3	0°	●		●	
SA16-3003N-T1	3,0	5,5	16	0,3	0°		●	●	

Hinweis: Bei linken und rechten Stechplatten muss ggf. das Trägerwerkzeug stirnseitig modifiziert werden.
Remark: When using left- or right-handed inserts the holder maybe needing modification.
Nota: Con l'utilizzo di inserti sinistri o destri può essere necessario modificare la lama.

P	○	●	●
M	●		○
K		●	
N			○
S			○
H			

● Hauptanwendung
Main application
Applicazione principale
○ Nebenanwendung
Secondary application
Applicazione secondaria

SA16

Geschliffene Ausführung / Ground execution / Esecuzione rettificato

							PG 38	
							beschichtet coated rivestito	
Bezeichnung Designation Articolo	EB - 0,15	H	L	R	χ	AM5040	AP5020	
SA16-1501R-S1-15	1,5	5,5	16	0,1	15°		●	
SA16-2001L/R-S1-12	2,0	5,5	16	0,1	12°	●		
SA16-2001L/R-T1-15	2,0	5,5	16	0,1	15°		●	
SA16-3002L/R-S1-12	3,0	5,5	16	0,2	12°	●		

Hinweis: Bei linken und rechten Stechplatten muss ggf. das Trägerwerkzeug stirnseitig modifiziert werden.
 Remark: When using left- or right-handed inserts the holder maybe needing modification.
 Nota: Con l'utilizzo di inserti sinistri o destri può essere necessario modificare la lama.

P	○	●
M	●	○
K		
N		○
S		○
H		

● Hauptanwendung
Main application
Applicazione principale
○ Nebenanwendung
Secondary application
Applicazione secondaria

1

Inserts
Inserti

SA17

1

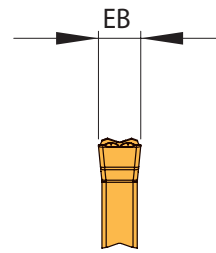
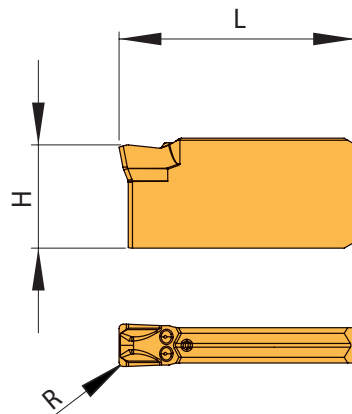

Gesinterte Ausführung / Sintered Execution / Esecuzione Sinterizzato

							PG 38		
							beschichtet coated rivestito		
Bezeichnung Designation Articolo	EB ± 0,04	H	L	R	χ	AM5040	AP2220	AP5020	
SA17-3003N-M1	3	7,5	16,75	0,3	0°		●	●	
SA17-3003N-T1	3	7,5	16,75	0,3	0°			●	
SA17-4004N-M1	4	7,5	16,75	0,4	0°		●	●	
SA17-4004N-S1	4	7,5	16,75	0,4	0°	●			

Hinweis: Bei linken und rechten Stechplatten muss ggf. das Trägerwerkzeug stirnseitig modifiziert werden.
Remark: When using left- or right-handed inserts the holder maybe needing modification.
Nota: Con l'utilizzo di inserti sinistri o destri può essere necessario modificare la lama.

Einseitige Schneideinsätze
Einseitige Schneideinsätze
Einseitige Schneideinsätze

P	○	●	●
M	●		○
K		●	
N			○
S			○
H			

● Hauptanwendung
Main application
Applicazione principale
○ Nebenanwendung
Secondary application
Applicazione secondaria

SA17

Präzisionsgeschliffene Ausführung / Precision ground execution / Esecuzione rettifica di precisione

							PG 38
							unbeschichtet uncoated non rivestito
Bezeichnung Designation Articolo	EB ± 0,02	H	L	R	χ	AN1015	
SA17-2001L/R-ALU-15	2	7,5	16,75	0,1	15°	●	
SA17-2002N-ALU	2	7,5	16,75	0,2	0°	●	
SA17-3002L/R-ALU-15	3	7,5	16,75	0,2	15°	●	
SA17-3003N-ALU	3	7,5	16,75	0,3	0°	●	

Hinweis: Bei linken und rechten Stechplatten muss ggf. das Trägerwerkzeug stirnseitig modifiziert werden.
 Remark: When using left- or right-handed inserts the holder maybe needing modification.
 Nota: Con l'utilizzo di inserti sinistri o destri può essere necessario modificare la lama.

Einseitige Schneideinsätze
 Einseitige Schneideinsätze
 Einseitige Schneideinsätze

P	
M	
K	○
N	●
S	○
H	

● Hauptanwendung
 Main application
 Applicazione principale
 ○ Nebenanwendung
 Secondary application
 Applicazione secondaria



SA24

1

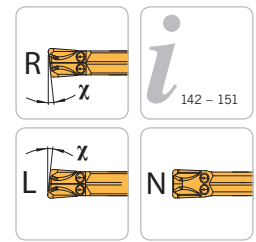
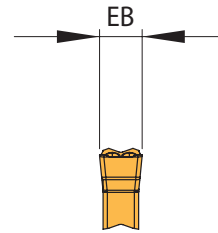
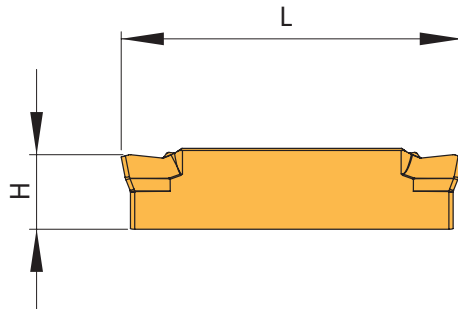

N NEU/NEW/
NUOVO

Gesinterte Ausführung / Sintered Execution / Esecuzione Sinterizzato

Bezeichnung Designation Articolo	EB ± 0,04	H	L	R	χ	PG 38					
						AM5040	AP2220	AP2240	AP5020	AP5030	AP5820+
SA24-1502N-S1	1,5	5,5	24	0,2	0°				●		
SA24-1502N-T1	1,5	5,5	24	0,2	0°				●		
SA24-2002N-F1	2,0	5,5	24	0,2	0°		●		●		
SA24-2002N-M1	2,0	5,5	24	0,2	0°		●	●	●		
SA24-2002N-S1	2,0	5,5	24	0,2	0°	●		●	●	●	
SA24-2002N-T1	2,0	5,5	24	0,2	0°	●	●	●	●		●
SA24-2502L/R-S1	2,5	5,5	24	0,2	6°	●			●		
SA24-2502L/R-T1	2,5	5,5	24	0,2	6°				●		
SA24-2502N-T1	2,5	5,5	24	0,2	0°						●
SA24-2503N-M1	2,5	5,5	24	0,3	0°				●		
SA24-2503N-S1	2,5	5,5	24	0,3	0°	●			●	●	
SA24-2503N-T1	2,5	5,5	24	0,3	0°				●	●	
SA24-3003L/R-M1	3,0	5,5	24	0,3	6°		●	●	●		
SA24-3003L/R-S1	3,0	5,5	24	0,3	6°	●					
SA24-3003L/R-T1	3,0	5,5	24	0,3	6°		●		●		
SA24-3003N-M1	3,0	5,5	24	0,3	0°		●		●		
SA24-3003N-S1	3,0	5,5	24	0,3	0°	●	●	●	●	●	
SA24-3003N-T1	3,0	5,5	24	0,3	0°	●	●	●	●	●	●
SA24-4004N-M1	4,0	5,5	24	0,4	0°		●		●		
SA24-4004N-S1	4,0	5,5	24	0,4	0°	●					
SA24-4004N-T1	4,0	5,5	24	0,4	0°				●		
SA24-5005N-M1	5,0	7,5	24	0,5	0°				●		
SA24-5005N-S1	5,0	7,5	24	0,5	0°				●		
SA24-5005N-T1	5,0	7,5	24	0,5	0°				●		

Hinweis: Bei linken und rechten Stechplatten muss ggf. das Trägerwerkzeug stirnseitig modifiziert werden.
Remark: When using left- or right-handed inserts the holder maybe needing modification.
Nota: Con l'utilizzo di inserti sinistri o destri può essere necessario modificare la lama.

P	○	●	●	●	●	●
M	●		○	○	○	○
K		●	●			
N				○		
S				○	○	●
H						

● Hauptanwendung
Main application
Applicazione principale
○ Nebenanwendung
Secondary application
Applicazione secondaria

SA24

Geschliffene Ausführung / Ground execution / Esecuzione rettificato

							PG 38	
							beschichtet coated rivestito	
Bezeichnung Designation Articolo	EB - 0,15	H	L	R	χ	AM5040	AP5020	
SA24-15005L/R-T1-15	1,5	5,5	24	0,05	15°		●	
SA24-1500L/R-S1-15	1,5	5,5	24	0,00	15°		●	
SA24-1501L/R-S1-15	1,5	5,5	24	0,10	15°		●	
SA24-2000R-T1-15	2,0	5,5	24	0,00	15°		●	
SA24-2001L/R-S1-12	2,0	5,5	24	0,10	12°	●		
SA24-2001L/R-S1-15	2,0	5,5	24	0,10	15°		●	
SA24-2001L/R-T1-15	2,0	5,5	24	0,10	15°		●	
SA24-2002L/R-S1-8	2,0	5,5	24	0,20	8°		●	
SA24-2502L/R-S1-8	2,5	5,5	24	0,20	8°		●	
SA24-3002L/R-S1-12	3,0	5,5	24	0,20	12°	●		
SA24-3002L-T1-15	3,0	5,5	24	0,20	15°		●	

Hinweis: Bei linken und rechten Stechplatten muss ggf. das Trägerwerkzeug stirnseitig modifiziert werden.
Remark: When using left- or right-handed inserts the holder maybe needing modification.
Nota: Con l'utilizzo di inserti sinistri o destri può essere necessario modificare la lama.

P	○	●
M	●	○
K		
N		○
S		○
H		

● Hauptanwendung
Main application
Applicazione principale
○ Nebenanwendung
Secondary application
Applicazione secondaria

Präzisionsgeschliffene Ausführung / Precision ground execution / Esecuzione rettifica di precisione

							PG 38 / 41 unbeschichtet uncoated non rivestito	
Bezeichnung Designation Articolo	EB ± 0,02	H	L	R	χ	AN8020 (PG 41)	AN1015 (PG 38)	
SA24-1502N	1,5	5,5	24	0,2	0°	●		
SA24-2001L/R-ALU-15	2,0	5,5	24	0,1	15°		●	
SA24-2002N	2,0	5,5	24	0,2	0°	●		
SA24-2002N-ALU	2,0	5,5	24	0,2	0°		●	
SA24-2002R-20	2,0	5,5	24	0,2	20°	●		
SA24-3002L/R-ALU-15	3,0	5,5	24	0,2	15°		●	
SA24-3003N-ALU	3,0	5,5	24	0,3	0°		●	

Hinweis: Bei linken und rechten Stechplatten muss ggf. das Trägerwerkzeug stirnseitig modifiziert werden.
Remark: When using left- or right-handed inserts the holder maybe needing modification.
Nota: Con l'utilizzo di inserti sinistri o destri può essere necessario modificare la lama.

P		
M		
K		○
N	●	●
S	○	○
H		

● Hauptanwendung
Main application
Applicazione principale
○ Nebenanwendung
Secondary application
Applicazione secondaria

Inserts
Inserti

SA24E



1

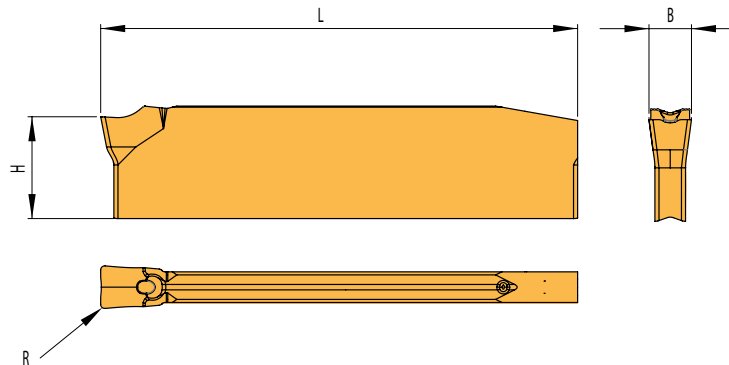

Gesinterte Ausführung / Sintered Execution / Esecuzione Sinterizzato

							PG 38
							beschichtet coated rivestito
Bezeichnung Designation Articolo	EB ± 0,04	H	L	R	χ	AP5020	
SA24E-2002N-S1	2	5,5	24	0,2	0°	●	
SA24E-3003N-S1	3	5,5	24	0,3	0°	●	

Hinweis: Bei linken und rechten Stechplatten muss ggf. das Trägerwerkzeug stirnseitig modifiziert werden.
Remark: When using left- or right-handed inserts the holder may need modification.
Nota: Con l'utilizzo di inserti sinistri o destri può essere necessario modificare la lama.

Schneideinsätze für selbstklemmende Klängen
Inserts for self-clamping blades
Inserti per lame a fissaggio

P	●
M	○
K	
N	○
S	○
H	

● Hauptanwendung
Main application
Applicazione principale
○ Nebenanwendung
Secondary application
Applicazione secondaria

Inserts
Inserti

SA35

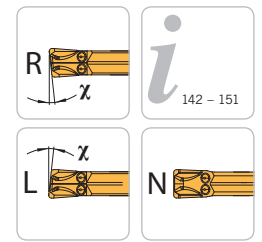
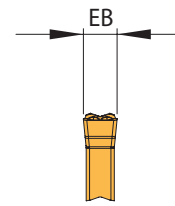
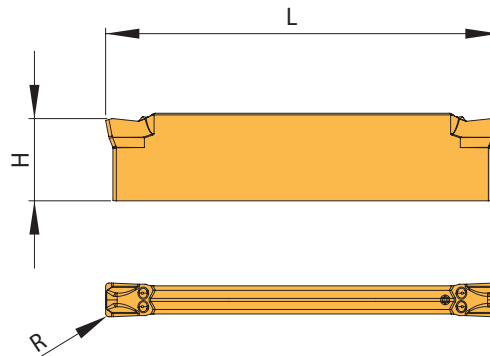

1

N NEU/NEW/
NUOVO

Gesinterte Ausführung / Sintered Execution / Esecuzione Sinterizzato

						PG 38				
						beschichtet coated rivestito				
Bezeichnung Designation Articolo	EB ± 0,04	H	L	R	χ	AM5040	AP2220	AP2240	AP5020	AP5030
SA35-2002L/R-M1	2	7,5	35	0,2	6°				●	
SA35-2002N-F1	2	7,5	35	0,2	0°		●		●	
SA35-2002N-M1	2	7,5	35	0,2	0°				●	
SA35-2002N-S1	2	7,5	35	0,2	0°	●		●	●	
SA35-2002N-T1	2	7,5	35	0,2	0°		●		●	
SA35-3003L/R-M1	3	7,5	35	0,3	6°		●	●	●	
SA35-3003L/R-S1	3	7,5	35	0,3	6°				●	
SA35-3003L/R-T1	3	7,5	35	0,3	6°		●		●	
SA35-3003N-M1	3	7,5	35	0,3	0°	●	●	●	●	
SA35-3003N-S1	3	7,5	35	0,3	0°	●		●	●	●
SA35-3003N-T1	3	7,5	35	0,3	0°	●	●	●	●	
SA35-4004N-M1	4	7,5	35	0,4	0°		●	●	●	
SA35-4004N-S1	4	7,5	35	0,4	0°	●				
SA35-4004N-T1	4	7,5	35	0,4	0°				●	
SA35-5005N-M1	5	7,5	35	0,5	0°				●	
SA35-6006N-M1	6	7,5	35	0,6	0°				●	

Hinweis: Bei linken und rechten Stechplatten muss ggf. das Trägerwerkzeug stirnseitig modifiziert werden.
Remark: When using left- or right-handed inserts the holder maybe needing modification.
Nota: Con l'utilizzo di inserti sinistri o destri può essere necessario modificare la lama.

P	○	●	●	●	●
M	●		○	○	○
K		●	●		
N				○	
S				○	○
H					

● Hauptanwendung
Main application
Applicazione principale
○ Nebenanwendung
Secondary application
Applicazione secondaria

SA35

Geschliffene Ausführung / Ground execution / Esecuzione rettificato

1

							PG 38	
							beschichtet coated rivestito	
Bezeichnung Designation Articolo	EB - 0,15	H	L	R	χ	AM5040	AP5020	
SA35-2001L/R-S1-12	2	7,5	35	0,1	12°	●		
SA35-2002L/R-S1-12 N	2	7,5	35	0,2	12°	●	●	
SA35-3002R-S1-12	3	7,5	35	0,2	12°	●	●	

Hinweis: Bei linken und rechten Stechplatten muss ggf. das Trägerwerkzeug stirnseitig modifiziert werden.
Remark: When using left- or right-handed inserts the holder maybe needing modification.
Nota: Con l'utilizzo di inserti sinistri o destri può essere necessario modificare la lama.

P	○	●
M	●	○
K		
N		○
S		○
H		

● Hauptanwendung
Main application
Applicazione principale

○ Nebenanwendung
Secondary application
Applicazione secondaria

Präzisionsgeschliffene Ausführung / Precision ground execution / Esecuzione rettifica di precisione

							PG 38 / 41	
							unbeschichtet uncoated non rivestito	
Bezeichnung Designation Articolo	EB ± 0,02	H	L	R	χ	AN8020 (PG 41)	AN1015 (PG 38)	
SA35-2000L/R-ALU-15	2	7,5	35	0,0	15°		●	
SA35-2001L/R-ALU-15	2	7,5	35	0,1	15°		●	
SA35-2002N-ALU	2	7,5	35	0,2	0°		●	
SA35-2002R-20 N	2	7,5	35	0,2	20°	●		
SA35-3002L/R-ALU-15	3	7,5	35	0,2	15°		●	
SA35-3002L/R-ALU-6 N	3	7,5	35	0,2	6°		●	
SA35-3003N-ALU	3	7,5	35	0,3	0°		●	
SA35-4004N-ALU	4	7,5	35	0,4	0°		●	

Hinweis: Bei linken und rechten Stechplatten muss ggf. das Trägerwerkzeug stirnseitig modifiziert werden.
Remark: When using left- or right-handed inserts the holder maybe needing modification.
Nota: Con l'utilizzo di inserti sinistri o destri può essere necessario modificare la lama.

P		
M		
K		○
N	●	●
S	○	○
H		

● Hauptanwendung
Main application
Applicazione principale

○ Nebenanwendung
Secondary application
Applicazione secondaria

SA35/SA40

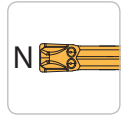
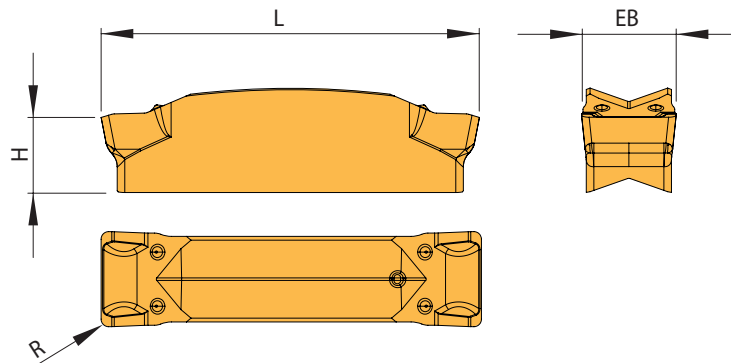

1

Gesinterte Ausführung / Sintered Execution / Esecuzione Sinterizzato

Bezeichnung Designation Articolo	EB ± 0,06	H	L	R	χ	PG 38	
						beschichtet coated rivestito	unbeschichtet uncoated non rivestito
SA35-8008N-M1	8	8,0	35	0,8	0°	●	
SA35-8040N-AEC	8	8,0	35	4,0	0°		●
SA40-10008N-M1	10	8,5	40	0,8	0°	●	

P	●	
M	○	
K		●
N	○	●
S	○	○
H		

● Hauptanwendung
Main application
Applicazione principale

○ Nebenanwendung
Secondary application
Applicazione secondaria

Spare parts and accessories
Ricambi e accessori

1

Artikel / Item / Articolo	PG 11
Schraube / Screw / Vite	
DIN912-M4x10-12.9	●
AS 0084	●
AS 0022-12	●
AS 0022	●
DIN912 M5X16-12.9	●
DIN912 M6X20-12.9	●
AS 0045	●
SA5T	●
AS 0049	●
AS 0050	●
Schlüssel / Key / Chiave	
KP 1111	●
KP 3111	●
T5215-IP	●
KP 1321	●
KP 5421	●
S-KSA	●
T5115-IP	●
T5220-IP	●
Kühlmittelschluss – gerade / Coolant supply – straight / Raccordo – dritto	
KA001	●
KA002	●
KA003	●
Kühlmittelschluss – winklig, fest / Coolant supply – angled and fixed / Raccordo – angolato	
KA004	●
KA005	●
Schwenkverschraubung / Swivelling screw-fitting / Raccordo – orientabile	
KA 006	●
KA 007	●
KA 008	●

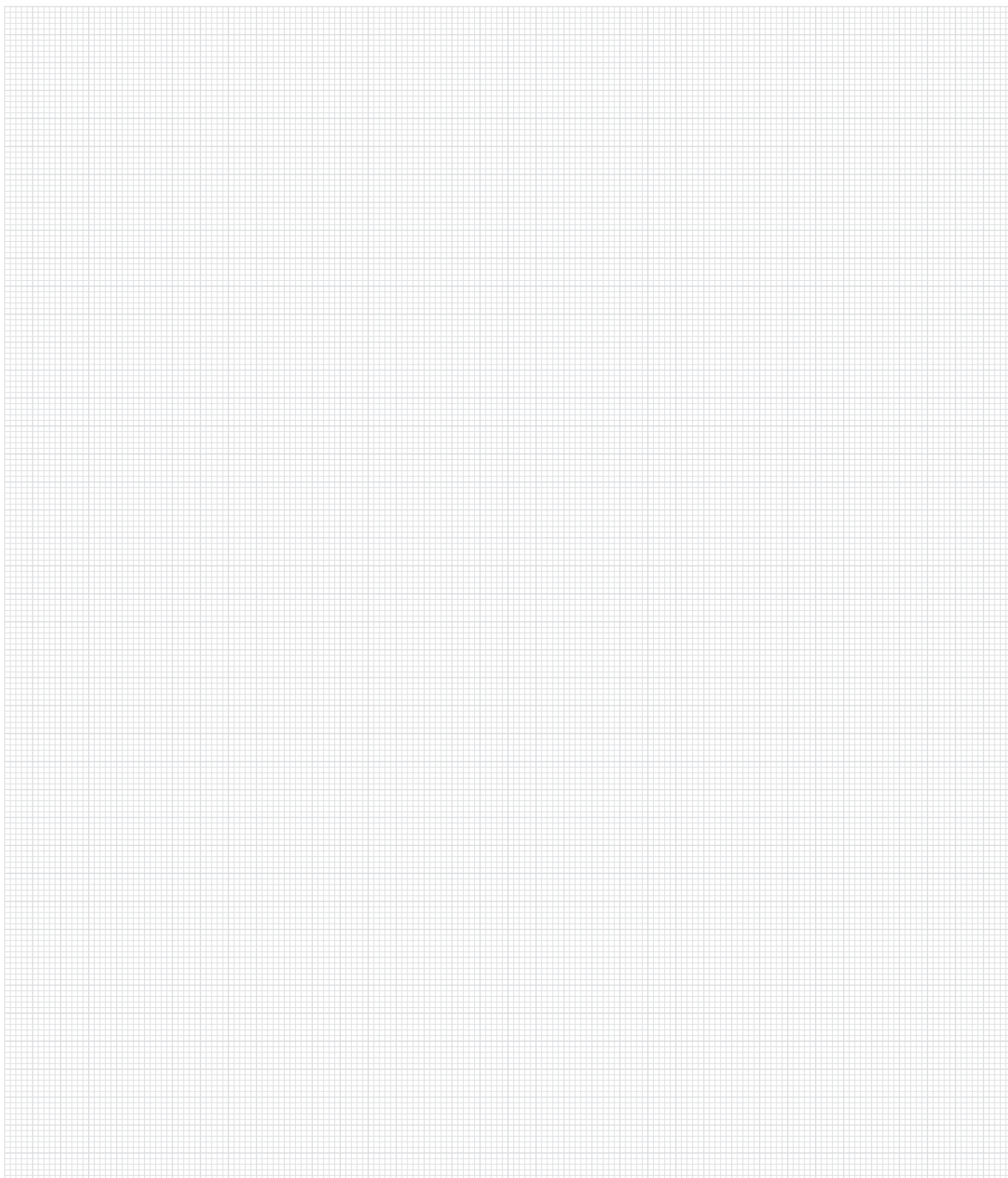

Weitere Informationen finden Sie unter:

For more information see:

Per maggiori informazioni visita il sito:

www.arno.de

Empfohlene Schnittwerte

1

Werkstoff- gruppe	Gliederung der Werkstoffhauptgruppen und Kennbuchstaben		Brinell-Härte	Zugfestigkeit (N/mm ²)	Zerspanungsgruppe	Schnittgeschwindigkeit V _c (m/min)			
						beschichtet			
						AM5040	AP2220	AP2240	
P	Unlegierter Stahl	C ≤ 0,25 % geglüht	125	428	P1	120 - 150 - 180	130 - 155 - 180	130 - 155 - 180	
		C > 0,25 ... ≤ 0,55 % geglüht	190	639	P2	80 - 115 - 150	110 - 145 - 180	110 - 145 - 180	
		C > 0,25 ... ≤ 0,55 % vergütet	210	708	P3	60 - 100 - 140	70 - 110 - 150	70 - 120 - 170	
		C > 0,55 % geglüht	190	639	P4	80 - 115 - 150	110 - 145 - 180	110 - 145 - 180	
		C > 0,55 % vergütet	300	1013	P5	60 - 100 - 140	70 - 110 - 150	70 - 120 - 170	
		Automatenstahl (kurzspanend) geglüht	220	745	P6	80 - 115 - 150	110 - 145 - 180	110 - 145 - 180	
	Niedrig legierter Stahl	geglüht	175	591	P7	80 - 120 - 160	120 - 150 - 180	120 - 150 - 180	
		vergütet	300	1013	P8	60 - 95 - 130	110 - 130 - 150	110 - 145 - 180	
		vergütet	380	1282	P9	60 - 95 - 130	110 - 130 - 150	110 - 145 - 180	
		vergütet	430	1477	P10	60 - 90 - 120	70 - 100 - 130	70 - 110 - 150	
Hochlegierter Stahl und hochlegierter Werkzeugstahl	geglüht	200	675	P11	80 - 110 - 140	90 - 115 - 140	90 - 130 - 170		
	gehärtet und angelassen	300	1013	P12	50 - 85 - 120	70 - 100 - 130	70 - 115 - 160		
	gehärtet und angelassen	400	1361	P13	50 - 85 - 120	70 - 100 - 130	70 - 115 - 160		
Nichtrostender Stahl	ferritisch / martensitisch, geglüht	200	675	P14	60 - 110 - 160	110 - 155 - 200	120 - 150 - 180		
	martensitisch, vergütet	330	1114	P15	50 - 75 - 100	60 - 95 - 130	60 - 80 - 100		
M	Nichtrostender Stahl	austenitisch, abgeschreckt	200	675	M1	60 - 90 - 120	-	100 - 110 - 120	
		austenitisch, ausscheidungsgehärtet (PH)	300	1013	M2	50 - 70 - 90	-	60 - 75 - 90	
		austenitisch-ferritisch, Duplex	230	778	M3	40 - 60 - 80	-	40 - 60 - 80	
K	Temperguss	ferritisch	200	675	K1	-	90 - 135 - 180	100 - 150 - 200	
		perritisch	260	867	K2	-	-	80 - 115 - 150	
	Grauguss	niedrige Festigkeit	180	602	K3	-	100 - 130 - 160	100 - 150 - 200	
		hohe Festigkeit / austenitisch	245	825	K4	-	110 - 145 - 180	90 - 135 - 180	
	Gusseisen mit Kugelgraphit	ferritisch	155	518	K5	-	100 - 130 - 160	100 - 130 - 160	
		perritisch	265	885	K6	-	120 - 170 - 220	70 - 105 - 140	
	GGV (CGI)		200	675	K7	-	90 - 135 - 180	100 - 150 - 200	
N	Aluminium-Knetlegierungen	nicht aushärtbar	30	-	N1	-	-	-	
		aushärtbar, ausgehärtet	100	343	N2	-	-	-	
		≤ 12 % Si, nicht aushärtbar	75	260	N3	-	-	-	
	Aluminium-Gusslegierungen	≤ 12 % Si, aushärtbar, ausgehärtet	90	314	N4	-	-	-	
		> 12 % Si, nicht aushärtbar	130	447	N5	-	-	-	
	Magnesiumlegierungen		70	250	N6	-	-	-	
	Kupfer und Kupferlegierungen (Bronze / Messing)	unlegiert, Elektrolytkupfer	100	343	N7	-	-	-	
		Messing, Bronze, Rotguss	90	314	N8	-	-	-	
		Cu-Legierung, kurzspanend	110	382	N9	-	-	-	
		hochfest, Ampco	300	1013	N10	-	-	-	
Nichtmetallische Werkstoffe	Thermoplaste (ohne abrasive Füllstoffe)	-	-	N11	-	-	-		
	Duroplaste (ohne abrasive Füllstoffe)	-	-	N12	-	-	-		
	Kunststoff glasfaserverstärkt GFRP	-	-	N13	-	-	-		
	Kunststoff kohlefaserverstärkt CFRP	-	-	N14	-	-	-		
	Kunststoff aramidfaserverstärkt AFRP	-	-	N15	-	-	-		
	Graphit (technisch)	80 Shore	-	N16	-	-	-		
S	Warmfeste Legierungen	Fe-Basis geglüht	200	675	S1	-	-	-	
		ausgehärtet	280	943	S2	-	-	-	
		geglüht	250	839	S3	-	-	-	
		Ni- oder Co-Basis ausgehärtet	350	1177	S4	-	-	-	
		gegossen	320	1076	S5	-	-	-	
	Titanlegierungen	Reintitan	200	675	S6	-	-	-	
		α- und β-Legierungen, ausgehärtet	375	1262	S7	-	-	-	
		β-Legierungen	410	1396	S8	-	-	-	
	Wolframlegierungen		300	1013	S9	-	-	-	
	Molybdänlegierungen		300	1013	S10	-	-	-	
H	Gehärteter Stahl	gehärtet und angelassen	50 HRC	-	H1	-	-	-	
		gehärtet und angelassen	55 HRC	-	H2	-	-	-	
		gehärtet und angelassen	60 HRC	-	H3	-	-	-	
	Gehärtetes Gusseisen	gehärtet und angelassen	55 HRC	-	H4	-	-	-	

Die Tabellenwerte sind Richtwerte.
Es kann notwendig sein, die Werte den jeweiligen Bearbeitungsumständen anzupassen.

			unbeschichtet			
	AP5020	AP5030	AP5820+	AK1015	AN1015	AN1015
	120 - 150 - 180	120 - 150 - 180	120 - 150 - 180	-	-	-
	80 - 115 - 150	80 - 115 - 150	80 - 115 - 150	-	-	-
	60 - 100 - 140	60 - 100 - 140	60 - 100 - 140	-	-	-
	80 - 115 - 150	80 - 115 - 150	80 - 115 - 150	-	-	-
	60 - 100 - 140	60 - 100 - 140	60 - 100 - 140	-	-	-
	80 - 115 - 150	80 - 115 - 150	80 - 115 - 150	-	-	-
	80 - 125 - 170	80 - 125 - 170	80 - 125 - 170	-	-	-
	60 - 95 - 130	60 - 95 - 130	60 - 95 - 130	-	-	-
	60 - 95 - 130	60 - 95 - 130	60 - 95 - 130	-	-	-
	60 - 90 - 120	60 - 90 - 120	60 - 90 - 120	-	-	-
	80 - 110 - 140	80 - 110 - 140	80 - 110 - 140	-	-	-
	50 - 85 - 120	50 - 85 - 120	50 - 85 - 120	-	-	-
	50 - 85 - 120	50 - 85 - 120	50 - 85 - 120	-	-	-
	60 - 115 - 170	60 - 115 - 170	60 - 115 - 170	-	-	-
	50 - 75 - 100	50 - 75 - 100	50 - 75 - 100	-	-	-
	60 - 90 - 120	60 - 90 - 120	60 - 90 - 120	-	-	-
	50 - 70 - 90	50 - 70 - 90	50 - 70 - 90	-	-	-
	50 - 70 - 90	45 - 65 - 85	50 - 70 - 90	-	-	-
	-	-	-	100 - 150 - 200	140 - 170 - 200	-
	-	-	-	80 - 120 - 160	120 - 140 - 160	-
	-	-	-	120 - 140 - 160	120 - 140 - 160	-
	-	-	-	100 - 120 - 140	100 - 125 - 150	-
	-	-	-	90 - 120 - 150	130 - 150 - 170	-
	-	-	-	100 - 140 - 180	90 - 110 - 130	-
	-	-	-	100 - 150 - 200	140 - 170 - 200	-
	100 - 300 - 500	-	-	100 - 450 - 800	300 - 400 - 500	2000-2250-2500
	100 - 200 - 300	-	-	80 - 440 - 800	200 - 250 - 300	2000-2250-2500
	100 - 300 - 500	-	-	80 - 290 - 500	100 - 300 - 500	1500-2000-2500
	100 - 200 - 300	-	-	-	100 - 200 - 300	1500-2000-2500
	100 - 150 - 200	-	-	-	100 - 150 - 200	800-1150-1500
	-	-	-	-	-	-
	100 - 200 - 300	-	-	130 - 215 - 300	150 - 275 - 300	-
	100 - 300 - 500	-	-	200 - 350 - 500	200 - 350 - 500	-
	100 - 200 - 300	-	-	130 - 215 - 300	150 - 275 - 300	-
	-	-	-	-	-	-
	80 - 130 - 180	-	-	100 - 300 - 500	80 - 130 - 180	-
	80 - 130 - 180	-	-	100 - 300 - 500	80 - 130 - 180	-
	60 - 105 - 150	-	-	80 - 115 - 150	60 - 105 - 150	-
	60 - 105 - 150	-	-	80 - 115 - 150	60 - 105 - 150	-
	60 - 105 - 150	-	-	80 - 115 - 150	60 - 105 - 150	-
	-	-	-	-	-	-
	20 - 35 - 50	20 - 35 - 50	30 - 45 - 55	-	30 - 40 - 45	-
	20 - 30 - 40	20 - 30 - 40	30 - 40 - 50	-	20 - 30 - 35	-
	15 - 20 - 25	15 - 20 - 25	25 - 30 - 35	-	15 - 20 - 25	-
	10 - 15 - 20	10 - 15 - 20	15 - 20 - 25	-	10 - 15 - 20	-
	10 - 15 - 20	10 - 15 - 20	15 - 20 - 25	-	10 - 15 - 20	-
	50 - 85 - 120	50 - 85 - 120	50 - 85 - 120	80 - 105 - 130	60 - 90 - 120	-
	30 - 40 - 50	30 - 40 - 50	35 - 55 - 60	40 - 55 - 70	30 - 40 - 50	-
	25 - 35 - 45	25 - 35 - 45	30 - 50 - 55	35 - 50 - 65	25 - 35 - 45	-
	-	-	-	-	-	-
	-	-	-	-	-	-
	-	-	-	-	-	-
	-	-	-	-	-	-
	-	-	-	-	-	-
	-	-	-	-	-	-

Recommended cutting data

1

Material group	Structure of the material groups and identification letters		Brinell hardness HB	Tensile strength Rm (N/mm ²)	Chipping group	Cutting speed V _c (m/min)			
						coated			
						AM5040	AP2220	AP2240	
P	Unalloyed steel	C ≤ 0.25 % annealed	125	428	P1	120 - 150 - 180	130 - 155 - 180	130 - 155 - 180	
		C > 0.25 ... ≤ 0.55 % annealed	190	639	P2	80 - 115 - 150	110 - 145 - 180	110 - 145 - 180	
		C > 0.25 ... ≤ 0.55 % hardened and tempered	210	708	P3	60 - 100 - 140	70 - 110 - 150	70 - 120 - 170	
		C > 0.55 % annealed	190	639	P4	80 - 115 - 150	110 - 145 - 180	110 - 145 - 180	
		C > 0.55 % hardened and tempered	300	1013	P5	60 - 100 - 140	70 - 110 - 150	70 - 120 - 170	
		Machining steel (short-chipping) tempered	220	745	P6	80 - 115 - 150	110 - 145 - 180	110 - 145 - 180	
	Low alloyed steel	annealed	175	591	P7	80 - 120 - 160	120 - 150 - 180	120 - 150 - 180	
		hardened and tempered	300	1013	P8	60 - 95 - 130	110 - 130 - 150	110 - 145 - 180	
		hardened and tempered	380	1282	P9	60 - 95 - 130	110 - 130 - 150	110 - 145 - 180	
		hardened and tempered	430	1477	P10	60 - 90 - 120	70 - 100 - 130	70 - 110 - 150	
	High alloyed steel and high alloyed tool steel	annealed	200	675	P11	80 - 110 - 140	90 - 115 - 140	90 - 130 - 170	
		hardened	300	1013	P12	50 - 85 - 120	70 - 100 - 130	70 - 115 - 160	
		hardened	400	1361	P13	50 - 85 - 120	70 - 100 - 130	70 - 115 - 160	
	Stainless steel	ferritic / martensitic, annealed	200	675	P14	60 - 110 - 160	110 - 155 - 200	120 - 150 - 180	
		martensitic, hardened and tempered	330	1114	P15	50 - 75 - 100	60 - 95 - 130	60 - 80 - 100	
M	Stainless steel	austenitic, chilled	200	675	M1	60 - 90 - 120	-	100 - 110 - 120	
		austenitic, precipitation-hardened (PH)	300	1013	M2	50 - 70 - 90	-	60 - 75 - 90	
		austenitic-ferritic, Duplex	230	778	M3	40 - 60 - 80	-	40 - 60 - 80	
K	Malleable cast iron	ferritic	200	675	K1	-	90 - 135 - 180	100 - 150 - 200	
		pearlitic	260	867	K2	-	-	80 - 115 - 150	
	Cast iron	low tensile strength	180	602	K3	-	100 - 130 - 160	100 - 150 - 200	
		high tensile strength / austenitic	245	825	K4	-	110 - 145 - 180	90 - 135 - 180	
	Cast iron with nodular graphite	ferritic	155	518	K5	-	100 - 130 - 160	100 - 130 - 160	
		pearlitic	265	885	K6	-	120 - 170 - 220	70 - 105 - 140	
	GGV (CGI)		200	675	K7	-	90 - 135 - 180	100 - 150 - 200	
N	Aluminium alloys long chipping	not heat treatable	30	-	N1	-	-	-	
		heat treatable, heat treated	100	343	N2	-	-	-	
		≤ 12 % Si, not heat treatable	75	260	N3	-	-	-	
	Casted aluminium alloys	≤ 12 % Si, aushärtbar, ausgehärtet	90	314	N4	-	-	-	
		> 12 % Si, not heat treatable	130	447	N5	-	-	-	
	Magnesium alloys		70	250	N6	-	-	-	
	Copper and copper alloys (Brass / Bronze)	Unalloyed, elektrolyte copper	100	343	N7	-	-	-	
		Brass, Bronze	90	314	N8	-	-	-	
		Cu-alloys, short-chipping	110	382	N9	-	-	-	
		High-tensile, Ampco	300	1013	N10	-	-	-	
	Non-ferrous materials	Lead alloys (without abrasive filling material)	-	-	N11	-	-	-	
Duroplastic (without abrasive filling material)		-	-	N12	-	-	-		
Plastic glas fibre reinforced GFRP		-	-	N13	-	-	-		
Plastic carbon fibre reinforced CFRP		-	-	N14	-	-	-		
Plastic aramid fibre reinforced AFRP		-	-	N15	-	-	-		
Graphite (tech.)			80 Shore	-	N16	-	-	-	
S	High temperature resistant alloys	Fe-Basis	annealed	200	675	S1	-	-	-
			heat treated	280	943	S2	-	-	-
		Ni- or Co-alloyed	annealed	250	839	S3	-	-	-
			heat treated	350	1177	S4	-	-	-
			casting	320	1076	S5	-	-	-
	Titanium alloys	Pure titan	200	675	S6	-	-	-	
		α- and β-alloys, heat treated	375	1262	S7	-	-	-	
		β-alloys	410	1396	S8	-	-	-	
	Wolfram alloys		300	1013	S9	-	-	-	
	Molybdän alloys		300	1013	S10	-	-	-	
H	Hardened steel	hardened	50 HRC	-	H1	-	-	-	
		hardened	55 HRC	-	H2	-	-	-	
		hardened	60 HRC	-	H3	-	-	-	
	Hardened cast iron	hardened	55 HRC	-	H4	-	-	-	

The recommended cutting data are only approximate values. It may be necessary to adjust them to each individual machining application.

			uncoated			
	AP5020	AP5030	AP5820+	AK1015	AN1015	AN8020
	120 - 150 - 180	120 - 150 - 180	120 - 150 - 180	-	-	-
	80 - 115 - 150	80 - 115 - 150	80 - 115 - 150	-	-	-
	60 - 100 - 140	60 - 100 - 140	60 - 100 - 140	-	-	-
	80 - 115 - 150	80 - 115 - 150	80 - 115 - 150	-	-	-
	60 - 100 - 140	60 - 100 - 140	60 - 100 - 140	-	-	-
	80 - 115 - 150	80 - 115 - 150	80 - 115 - 150	-	-	-
	80 - 125 - 170	80 - 125 - 170	80 - 125 - 170	-	-	-
	60 - 95 - 130	60 - 95 - 130	60 - 95 - 130	-	-	-
	60 - 95 - 130	60 - 95 - 130	60 - 95 - 130	-	-	-
	60 - 90 - 120	60 - 90 - 120	60 - 90 - 120	-	-	-
	80 - 110 - 140	80 - 110 - 140	80 - 110 - 140	-	-	-
	50 - 85 - 120	50 - 85 - 120	50 - 85 - 120	-	-	-
	50 - 85 - 120	50 - 85 - 120	50 - 85 - 120	-	-	-
	60 - 115 - 170	60 - 115 - 170	60 - 115 - 170	-	-	-
	50 - 75 - 100	50 - 75 - 100	50 - 75 - 100	-	-	-
	60 - 90 - 120	60 - 90 - 120	60 - 90 - 120	-	-	-
	50 - 70 - 90	50 - 70 - 90	50 - 70 - 90	-	-	-
	50 - 70 - 90	45 - 65 - 85	50 - 70 - 90	-	-	-
	-	-	-	100 - 150 - 200	140 - 170 - 200	-
	-	-	-	80 - 120 - 160	120 - 140 - 160	-
	-	-	-	120 - 140 - 160	120 - 140 - 160	-
	-	-	-	100 - 120 - 140	100 - 125 - 150	-
	-	-	-	90 - 120 - 150	130 - 150 - 170	-
	-	-	-	100 - 140 - 180	90 - 110 - 130	-
	-	-	-	100 - 150 - 200	140 - 170 - 200	-
	100 - 300 - 500	-	-	100 - 450 - 800	300 - 400 - 500	2000-2250-2500
	100 - 200 - 300	-	-	80 - 440 - 800	200 - 250 - 300	2000-2250-2500
	100 - 300 - 500	-	-	80 - 290 - 500	100 - 300 - 500	1500-2000-2500
	100 - 200 - 300	-	-	-	100 - 200 - 300	1500-2000-2500
	100 - 150 - 200	-	-	-	100 - 150 - 200	800-1150-1500
	-	-	-	-	-	-
	100 - 200 - 300	-	-	130 - 215 - 300	150 - 275 - 300	-
	100 - 300 - 500	-	-	200 - 350 - 500	200 - 350 - 500	-
	100 - 200 - 300	-	-	130 - 215 - 300	150 - 275 - 300	-
	-	-	-	-	-	-
	80 - 130 - 180	-	-	100 - 300 - 500	80 - 130 - 180	-
	80 - 130 - 180	-	-	100 - 300 - 500	80 - 130 - 180	-
	60 - 105 - 150	-	-	80 - 115 - 150	60 - 105 - 150	-
	60 - 105 - 150	-	-	80 - 115 - 150	60 - 105 - 150	-
	60 - 105 - 150	-	-	80 - 115 - 150	60 - 105 - 150	-
	-	-	-	-	-	-
	20 - 35 - 50	20 - 35 - 50	30 - 45 - 55	-	30 - 40 - 45	-
	20 - 30 - 40	20 - 30 - 40	30 - 40 - 50	-	20 - 30 - 35	-
	15 - 20 - 25	15 - 20 - 25	25 - 30 - 35	-	15 - 20 - 25	-
	10 - 15 - 20	10 - 15 - 20	15 - 20 - 25	-	10 - 15 - 20	-
	10 - 15 - 20	10 - 15 - 20	15 - 20 - 25	-	10 - 15 - 20	-
	50 - 85 - 120	50 - 85 - 120	50 - 85 - 120	80 - 105 - 130	60 - 90 - 120	-
	30 - 40 - 50	30 - 40 - 50	35 - 55 - 60	40 - 55 - 70	30 - 40 - 50	-
	25 - 35 - 45	25 - 35 - 45	30 - 50 - 55	35 - 50 - 65	25 - 35 - 45	-
	-	-	-	-	-	-
	-	-	-	-	-	-
	-	-	-	-	-	-
	-	-	-	-	-	-
	-	-	-	-	-	-
	-	-	-	-	-	-

Parametri di taglio suggeriti

1

Gruppo materiale	Struttura dei gruppi di materiali e lettere di riferimento		Durezza Brinell	Resistenza Rm (N/mm ²)	Gruppo di lavoro	Velocità di taglio V _c (m/min)		
						rivestito		
						AM5040	AP2220	AP2240
P	Acciai non legato	C ≤ 0,25 % ricotto	125	428	P1	120 - 150 - 180	130 - 155 - 180	130 - 155 - 180
		C > 0,25 ... ≤ 0,55 % ricotto	190	639	P2	80 - 115 - 150	110 - 145 - 180	110 - 145 - 180
		C > 0,25 ... ≤ 0,55 % bonificato	210	708	P3	60 - 100 - 140	70 - 110 - 150	70 - 120 - 170
		C > 0,55 % ricotto	190	639	P4	80 - 115 - 150	110 - 145 - 180	110 - 145 - 180
		C > 0,55 % bonificato	300	1013	P5	60 - 100 - 140	70 - 110 - 150	70 - 120 - 170
	Acciai debolmente legati	Acciaio (truciolo corto) ricotto	220	745	P6	80 - 115 - 150	110 - 145 - 180	110 - 145 - 180
		ricotto	175	591	P7	80 - 120 - 160	120 - 150 - 180	120 - 150 - 180
		bonificato	300	1013	P8	60 - 95 - 130	110 - 130 - 150	110 - 145 - 180
		bonificato	380	1282	P9	60 - 95 - 130	110 - 130 - 150	110 - 145 - 180
		bonificato	430	1477	P10	60 - 90 - 120	70 - 100 - 130	70 - 110 - 150
Acciai fortemente legati e acciai da utensili	ricotto	200	675	P11	80 - 110 - 140	90 - 115 - 140	90 - 130 - 170	
	temprato e rinvenuto	300	1013	P12	50 - 85 - 120	70 - 100 - 130	70 - 115 - 160	
	temprato e rinvenuto	400	1361	P13	50 - 85 - 120	70 - 100 - 130	70 - 115 - 160	
Acciai inossidabili	ferritico / martensitico, ricotto	200	675	P14	60 - 110 - 160	110 - 155 - 200	120 - 150 - 180	
	martensitico, bonificato	330	1114	P15	50 - 75 - 100	60 - 95 - 130	60 - 80 - 100	
M	Acciai inossidabili	austenitico, trattato o temperato	200	675	M1	60 - 90 - 120	-	100 - 110 - 120
		austenitico, indurimento per precipitazione (PH)	300	1013	M2	50 - 70 - 90	-	60 - 75 - 90
		austenitico-ferritico, Duplex	230	778	M3	40 - 60 - 80	-	40 - 60 - 80
K	Ghisa temprata	ferritico	200	675	K1	-	90 - 135 - 180	100 - 150 - 200
		perlitica	260	867	K2	-	-	80 - 115 - 150
	Ghisa grigia	bassa resistenza	180	602	K3	-	100 - 130 - 160	100 - 150 - 200
		alta resistenza / austenitico	245	825	K4	-	110 - 145 - 180	90 - 135 - 180
	Ghisa sferoidale	ferritico	155	518	K5	-	100 - 130 - 160	100 - 130 - 160
		perlitica	265	885	K6	-	120 - 170 - 220	70 - 105 - 140
GGV (CGI)		200	675	K7	-	90 - 135 - 180	100 - 150 - 200	
N	Leghe di Alluminio stampato	non invecchiato	30	-	N1	-	-	-
		rinvenuto, invecchiato	100	343	N2	-	-	-
		≤ 12 % Si, non invecchiato	75	260	N3	-	-	-
	Leghe di Alluminio da fusione	≤ 12 % Si, rinvenuto, invecchiato	90	314	N4	-	-	-
		> 12 % Si, non invecchiato	130	447	N5	-	-	-
	Leghe di magnesio		70	250	N6	-	-	-
	Rame e Leghe di Rame (Bronzo / Ottone)	Non legati, Rame Elettrolitico	100	343	N7	-	-	-
		Ottone, Bronzo	90	314	N8	-	-	-
		Leghe Cu, truciolo corto	110	382	N9	-	-	-
		Alta resistenza, Ampco	300	1013	N10	-	-	-
Materiali non metallici	Leghe al piombo (senza materiale di riempimento abrasivo)	-	-	N11	-	-	-	
	Duroplastico (senza materiale di riempimento abrasivo)	-	-	N12	-	-	-	
	Plastica rinforzata in fibra di vetro GFRP	-	-	N13	-	-	-	
	Plastica rinforzata in fibra di carbonio CFRP	-	-	N14	-	-	-	
	Plastica rinforzata in fibra aramidica AFRP	-	-	N15	-	-	-	
	Grafite (tecnico)		80 Shore	-	N16	-	-	-
S	Leghe resistenti al calore	Base-Fe ricotto	200	675	S1	-	-	-
		invecchiato	280	943	S2	-	-	-
		Base Ni o Co ricotto	250	839	S3	-	-	-
		invecchiato	350	1177	S4	-	-	-
		da fusione	320	1076	S5	-	-	-
	Leghe di Titanio	Titanio puro	200	675	S6	-	-	-
		Leghe α e β, invecchiato	375	1262	S7	-	-	-
		Leghe β	410	1396	S8	-	-	-
	Leghe di tungsteno		300	1013	S9	-	-	-
	Leghe di molibdeno		300	1013	S10	-	-	-
H	Acciaio Temprato	temprato e rinvenuto	50 HRC	-	H1	-	-	-
		temprato e rinvenuto	55 HRC	-	H2	-	-	-
		temprato e rinvenuto	60 HRC	-	H3	-	-	-
	Ghisa Temprata	temprato e rinvenuto	55 HRC	-	H4	-	-	-

I dati indicati in tabella sono valori approssimati.
Può essere necessario adattarli alle singole applicazioni di lavorazione.

			non rivestito			
	AP5020	AP5030	AP5820+	AK1015	AN1015	AN8020
	120 - 150 - 180	120 - 150 - 180	120 - 150 - 180	-	-	-
	80 - 115 - 150	80 - 115 - 150	80 - 115 - 150	-	-	-
	60 - 100 - 140	60 - 100 - 140	60 - 100 - 140	-	-	-
	80 - 115 - 150	80 - 115 - 150	80 - 115 - 150	-	-	-
	60 - 100 - 140	60 - 100 - 140	60 - 100 - 140	-	-	-
	80 - 115 - 150	80 - 115 - 150	80 - 115 - 150	-	-	-
	80 - 125 - 170	80 - 125 - 170	80 - 125 - 170	-	-	-
	60 - 95 - 130	60 - 95 - 130	60 - 95 - 130	-	-	-
	60 - 95 - 130	60 - 95 - 130	60 - 95 - 130	-	-	-
	60 - 90 - 120	60 - 90 - 120	60 - 90 - 120	-	-	-
	80 - 110 - 140	80 - 110 - 140	80 - 110 - 140	-	-	-
	50 - 85 - 120	50 - 85 - 120	50 - 85 - 120	-	-	-
	50 - 85 - 120	50 - 85 - 120	50 - 85 - 120	-	-	-
	60 - 115 - 170	60 - 115 - 170	60 - 115 - 170	-	-	-
	50 - 75 - 100	50 - 75 - 100	50 - 75 - 100	-	-	-
	60 - 90 - 120	60 - 90 - 120	60 - 90 - 120	-	-	-
	50 - 70 - 90	50 - 70 - 90	50 - 70 - 90	-	-	-
	50 - 70 - 90	45 - 65 - 85	50 - 70 - 90	-	-	-
	-	-	-	100 - 150 - 200	140 - 170 - 200	-
	-	-	-	80 - 120 - 160	120 - 140 - 160	-
	-	-	-	120 - 140 - 160	120 - 140 - 160	-
	-	-	-	100 - 120 - 140	100 - 125 - 150	-
	-	-	-	90 - 120 - 150	130 - 150 - 170	-
	-	-	-	100 - 140 - 180	90 - 110 - 130	-
	-	-	-	100 - 150 - 200	140 - 170 - 200	-
	100 - 300 - 500	-	-	100 - 450 - 800	300 - 400 - 500	2000-2250-2500
	100 - 200 - 300	-	-	80 - 440 - 800	200 - 250 - 300	2000-2250-2500
	100 - 300 - 500	-	-	80 - 290 - 500	100 - 300 - 500	1500-2000-2500
	100 - 200 - 300	-	-	-	100 - 200 - 300	1500-2000-2500
	100 - 150 - 200	-	-	-	100 - 150 - 200	800-1150-1500
	-	-	-	-	-	-
	100 - 200 - 300	-	-	130 - 215 - 300	150 - 275 - 300	-
	100 - 300 - 500	-	-	200 - 350 - 500	200 - 350 - 500	-
	100 - 200 - 300	-	-	130 - 215 - 300	150 - 275 - 300	-
	-	-	-	-	-	-
	80 - 130 - 180	-	-	100 - 300 - 500	80 - 130 - 180	-
	80 - 130 - 180	-	-	100 - 300 - 500	80 - 130 - 180	-
	60 - 105 - 150	-	-	80 - 115 - 150	60 - 105 - 150	-
	60 - 105 - 150	-	-	80 - 115 - 150	60 - 105 - 150	-
	60 - 105 - 150	-	-	80 - 115 - 150	60 - 105 - 150	-
	-	-	-	-	-	-
	20 - 35 - 50	20 - 35 - 50	30 - 45 - 55	-	30 - 40 - 45	-
	20 - 30 - 40	20 - 30 - 40	30 - 40 - 50	-	20 - 30 - 35	-
	15 - 20 - 25	15 - 20 - 25	25 - 30 - 35	-	15 - 20 - 25	-
	10 - 15 - 20	10 - 15 - 20	15 - 20 - 25	-	10 - 15 - 20	-
	10 - 15 - 20	10 - 15 - 20	15 - 20 - 25	-	10 - 15 - 20	-
	50 - 85 - 120	50 - 85 - 120	50 - 85 - 120	80 - 105 - 130	60 - 90 - 120	-
	30 - 40 - 50	30 - 40 - 50	35 - 55 - 60	40 - 55 - 70	30 - 40 - 50	-
	25 - 35 - 45	25 - 35 - 45	30 - 50 - 55	35 - 50 - 65	25 - 35 - 45	-
	-	-	-	-	-	-
	-	-	-	-	-	-
	-	-	-	-	-	-
	-	-	-	-	-	-
	-	-	-	-	-	-
	-	-	-	-	-	-

Einsatzempfehlung / Application recommendations / Consigli di utilizzo

1

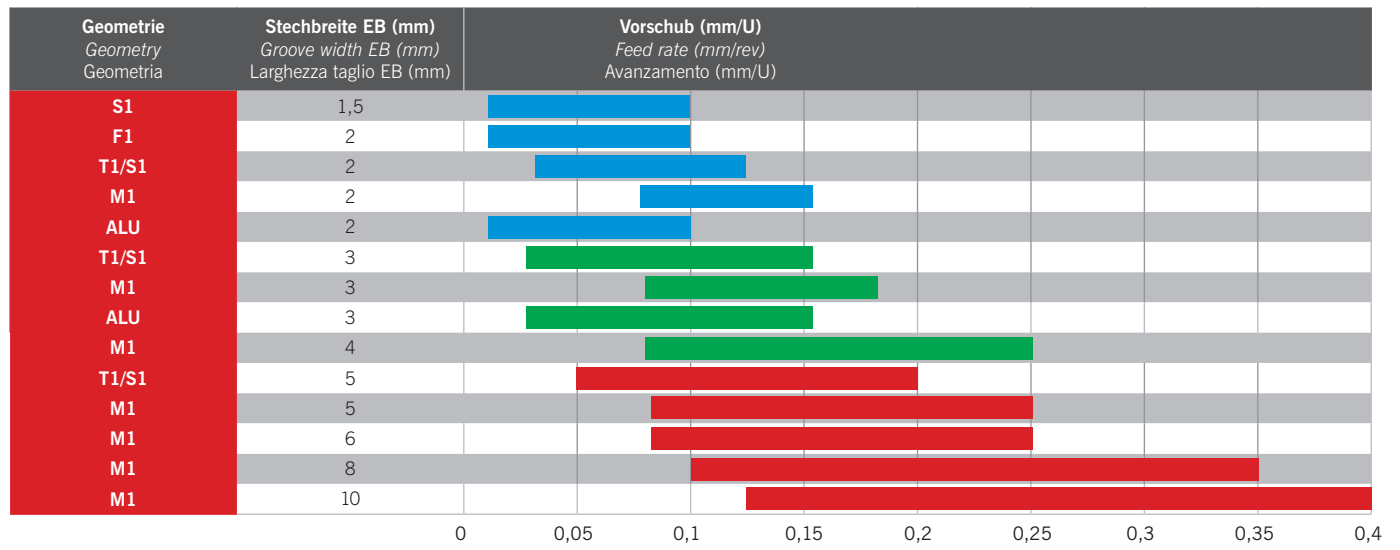

Montagehinweis KSA...-N / KSA mounting instructions ...-N /

Schema di montaggio KSA ...-N

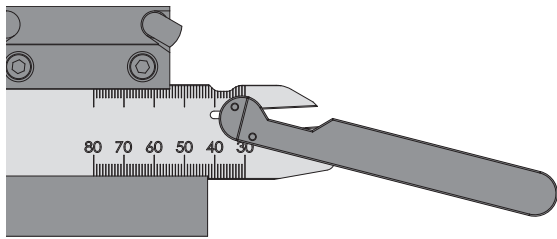

**Montageschlüssel in die 2 Ausnehmungen stecken.
(von beiden Seiten möglich)**

*Place the mounting wrench in the 2 recesses.
(possible from both sides)*

Inserire la chiave di apertura nei due fori.
(possibile da entrambi i lati)

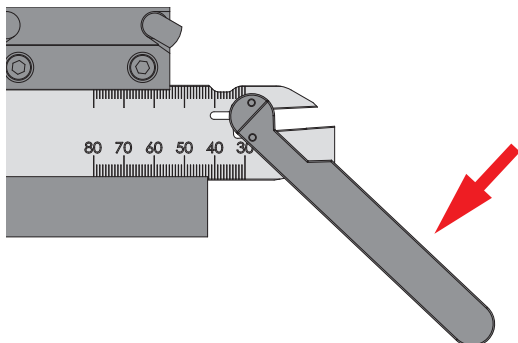

**Durch Bewegung des Montageschlüssels in Pfeilrichtung
wird der Plattensitz geöffnet.**

*The insert seat is opened by moving the mounting wrench
in the direction of the arrow.*

La sede inserto viene aperta ruotando la chiave nella direzione
della freccia.

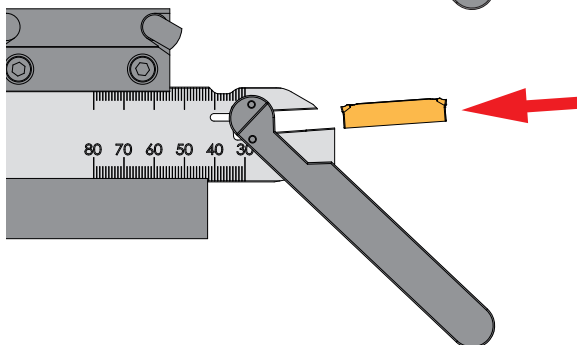

**Schneideinsatz einlegen und durch Andrücken
gegen den Anschlag positionieren.**

*Engage the cutting insert and position against
the stop by pressing in.*

Inserire l'inserto da taglio fino al fermo.

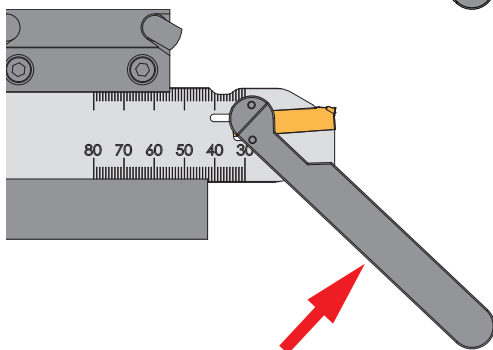

**Montageschlüssel nach vorne bewegen. Plattensitz schließt
sich wieder und der Schneideinsatz wird gespannt.**

*Move the mounting wrench forwards. The plate seat closes
again and the cutting insert is tightened.*

Ruotare in senso opposto la chiave. La sede si chiude e
l'inserto viene bloccato.

**Die Klemmung ist so konzipiert, dass der Montageschlüssel entsprechend
der Zugängigkeit von beiden Seiten in die Klinge gesteckt werden kann.**

The clamping is designed so that the mounting wrench can be pushed
into the blade from both sides depending on accessibility.

Il bloccaggio prevede che la chiave si possa utilizzare da entrambe i
lati in base alla accessibilità.

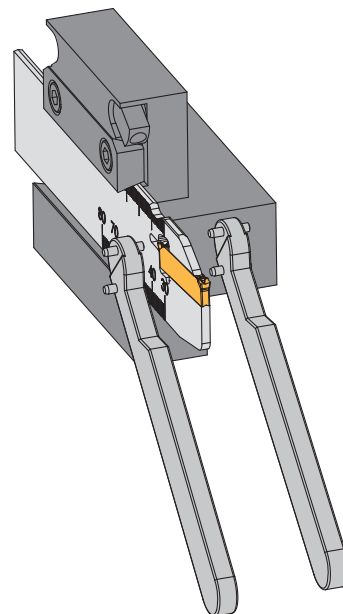

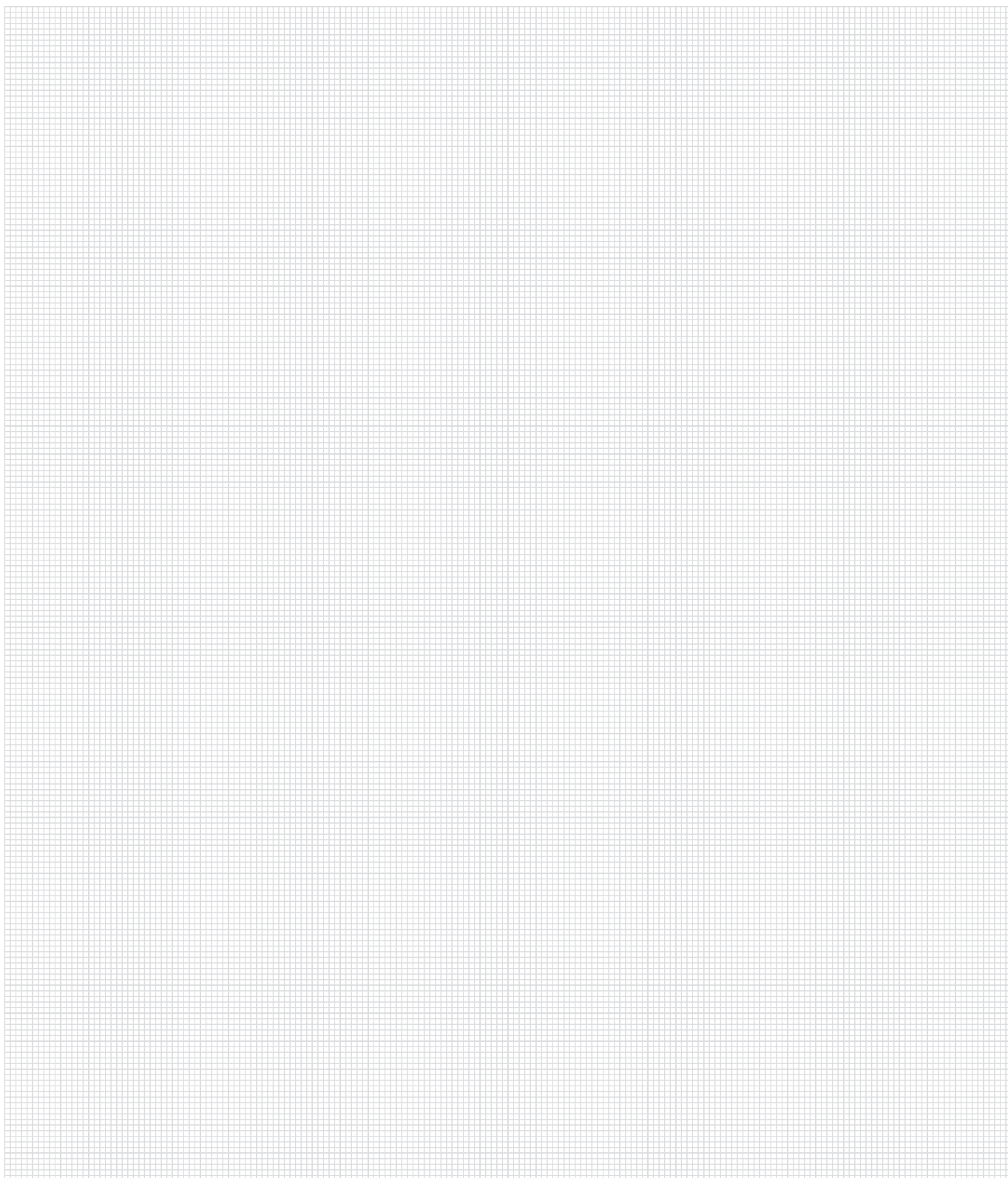

ARNO[®]
WERKZEUGE

Weitere Informationen finden Sie unter:

For more information see:

Per maggiori informazioni visita il sito:

www.arno.de

SE-Steichsystem*SE-Grooving system*

SE-Sistema di troncatura

Ein- und Absteichsystem

Grooving and parting system

Sistema di troncatura e scanalatura

• Systemvorstellung	• <i>Introduction</i>	• Caratteristiche del sistema	154 – 159
• Monoblockhalter	• <i>Monoblock holders</i>	• Utensili monoblocco	160 – 183
– Werkzeugauswahl	– <i>Tool shank options</i>	– Tipologie di corpo utensile	160
– Bezeichnungssystem	– <i>Designation system</i>	– Sistema di identificazione	161
– Monoblockhalter	– <i>Monoblock holders</i>	– Utensili monoblocco	162 – 183
• Schneideinsätze	• <i>Inserts</i>	• Inserti	184 – 187
– Geometrie	– <i>Geometry</i>	– Geometria	184
– Sortenbeschreibung	– <i>Grade description</i>	– Descrizione delle Qualità	185
– Schneideinsätze	– <i>Inserts</i>	– Inserti	186 – 187
• Ersatzteile und Zubehör	• <i>Spare parts and accessories</i>	• Ricambi e accessori	188
• Schnittwerte	• <i>Cutting data</i>	• Parametri di taglio	189 – 195
• Anwendungshinweise	• <i>Application reference</i>	• Suggerimenti tecnici	196 – 198



Monoblockhalter SE zum Einstechen, Abstechen und Kopierdrehen

Monoblockholder „SE“ for grooving, parting and copy turning

Steli monoblocco „SE“ per scanalatura, troncatura e copiatura

2

Monoblockhalter 12 x 12 bis 25 x 25 mm

Monoblockholder

12 x 12 to 25 x 25 mm

Utensili monoblocco da
12 x 12 a 25 x 25 mm



Einstechen

Grooving

Scanalatura

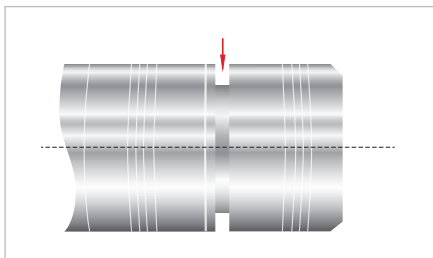

Abstechen

Parting

Troncatura

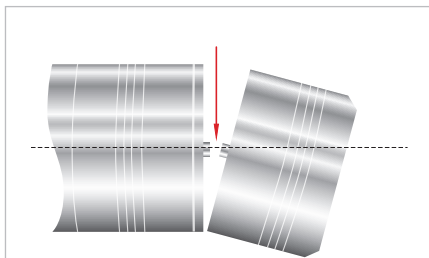

Kopierdrehen

Copy turning

Copiatura

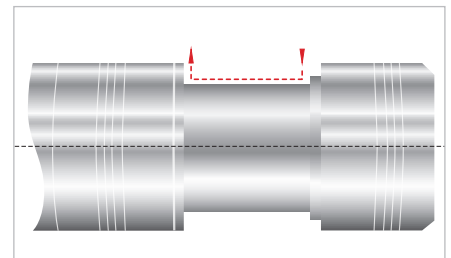

Systemvorstellung

Monoblockhalter „SE“ für zweiseitige Wendeschneidplatten in der Größe SE24 mit den Stechbreiten 2 bis 6 mm.

- Schneideinsätze mit EB = 2 bis 6 mm in drei Geometrien und fünf Sorten erhältlich.
- Grundhalter 16 × 16 bis 25 × 25 mm
- Zum Einstechen, Abstechen und Kopierdrehen
- Mit und ohne ACS1-Innenkühlung (Kühlung direkt in der Schnittzone) erhältlich.
- In Einstechtiefen ET = 12 mm und ET = 21 mm

Introduction

Monoblockholder "SE" for double sided inserts size SE24 with groove width from 2 – 6 mm

- Inserts with groove width from 2 to 6mm with three geometries and 5 available grades
- Shank sizes from 16 x 16 to 25 x 25 mm
- For grooving, part-off and copy turning (-M2 geometry)
- Available with or without ACS1 through tool coolant (coolant straight to the cutting edge)
- Available in both 12mm and 21 mm groove depths

Descrizione

Steli monoblocco "SE" per inserti bitaglianti dimensione SE24

in larghezze da 2 a 6 mm

- Inserti con larghezze da 2 a 6mm con 3 geometrie e 5 qualità di metallo duro
- Steli da 16 x 16 fino a 25 x 25 mm
- Per scanalatura, troncatura e scanalatura di copiatura (Geometria -M2)
- Disponibile con ACS1 ed senza refrigerazione interna (ACS permette il refrigerante direttamente al punto di taglio)
- Disponibile per le profondità di gola 12 mm e 21 mm

Fakten

- Monoblockausführung
 - Anwendungssicher, einfaches Handling – nur ein Ersatzteil
- Aktive Wendeschneidplattenklemmung mit Fixanschlag
 - Genaue Schneidenpositionierung im Doppelprisma – kein Herausziehen der Wendeschneidplatte möglich
- Zweiseitige Wendeschneidplatten
 - Hohe Wirtschaftlichkeit
- Direkt gepresste Wendeschneidplatte mit speziellen Geometrien
 - Kostengünstige und optimale Lösung für sichere Stechprozesse
- Gesinterte Ausführung
 - Die Geometrie M2 ist dabei speziell zum Einstechen-, Längs und Kopierdrehen von Stahl und rostfreien Werkstoffen konzipiert, die Geometrie T1 ist für die Bearbeitung von Stahl, rostfreiem Stahl und Gusswerkstoffen geeignet

Features

- Monoblock design
 - Reliable and user friendly – only one spare part
- Active insert clamping with fixed stop
 - Accurate insert positioning. Pulling out the insert is not possible
- Double edged inserts
 - High productivity
- Directly pressed inserts with dedicated geometries
 - Cost efficient and optimum solution for reliable groove production
- Ground version
 - First choice for grooving and turning
- Main application for steel and stainless steel
- Strong cutting edge for maximum feed rates and cutting depths

Caratteristiche

- Monoblocco
 - Sicuro e di semplice utilizzo – senza ricambi
- Bloccaggio assiale con fermo
 - Posizionamento preciso e sicuro dell' inserto impossibile lo spostamento in sede
- Bi-tagliente
 - Economico
- Inserti con geometrie specifiche
 - Forme specifiche per materiali e per una lavorazione affidabile
- Versione sinterizzato
 - Prima scelta per la scanalatura e tornitura longitudinale Principale applicazione su acciaio e acciai inossidabili Geometria robusta per massima velocità di avanzamento e profondità di taglio

ARNO-ACS cooling system®

Patentierter Kühlung durch Unterspülung

Coolant under the swarf

Refrigerante sotto il truciolo

2

ACS1

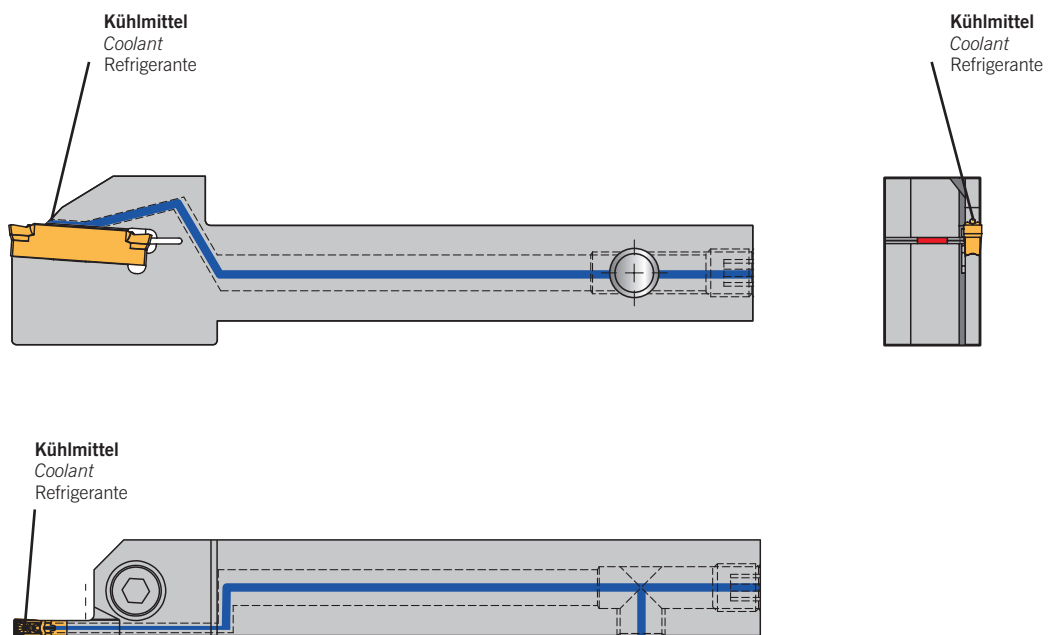

Neue Technologie für Stechmodule, Klingen und Monoblockhalter. Spezielles Kühlungssystem sichert die Unterspülung des Spanes und verbessert Standzeiten deutlich.

Bisher gibt es am Markt externe sowie interne Kühlungsvarianten, die jedoch oft einen erheblichen Streuungsverlust bis zur Schneidkante aufweisen. Besonders bei tieferen Ein- und Abstichen reduziert sich dadurch der Kühlungseffekt enorm und der Abtransport der Späne wird erschwert.

ARNO®-Werkzeuge hat diese Probleme erkannt und mittels neu entwickelter Technik, dem ARNO-ACS cooling system® (ACS), erfolgreich beseitigt. Dieses innovative System ermöglicht die optimale Kühlung der Stechplatte während der Bearbeitung. Es stehen zwei Kühlvarianten zur Verfügung: ACS1 mit einem Kühlmittelkanal sowie ACS2 mit zwei Kühlmittelkanälen.

New technology for modules, blades and monoblock holders. The special coolant system ensures the flow is directed under the swarf and thereby improves tool life considerably.

The market place has already seen many coolant variations which often loses much of efficiency due to poor accuracy from the spray jet to the cutting edge and especially in applications with a deeper groove depth the desired coolant effect and swarf evacuation suffers from only little or no improvement.

ARNO®-Werkzeuge has realised this problem area and by developing the ARNO®-Cooling-System (ACS) solved the problem. This innovative design ensures optimum coolant to the cutting edge during machining. It comes in two variations: ACS1, with one coolant hole and ACS2 with two coolant holes.

Nuova tecnologia per moduli, lame e steli integrali. Lo speciale passaggio del refrigerante assicura di raggiungere il punto più vicino possibile alla zona di taglio riducendo le temperature e incrementando la vita inserto considerevolmente.

Il mercato offre oggi innumerevoli sistemi di adduzione che però perdono la loro efficienza con la distanza dal punto di taglio o per la bassa precisione del getto. Nei casi di gole molto profonde questo ha un significato importantissimo anche per una migliore evacuazione truciolo.

ARNO®-Werkzeuge ha identificato queste problematiche e su queste focalizzato la ricerca e sviluppo che con il nuovo sistema di refrigerazione ARNO® ACS ha eliminato con successo. Questo sistema innovativo consente un raffreddamento ottimale del tagliente, degli utensili e del materiale durante la lavorazione. Due sono le opzioni di raffreddamento disponibili: ACS1 con un solo canale di refrigerazione e ACS2 con due canali di refrigerazione.

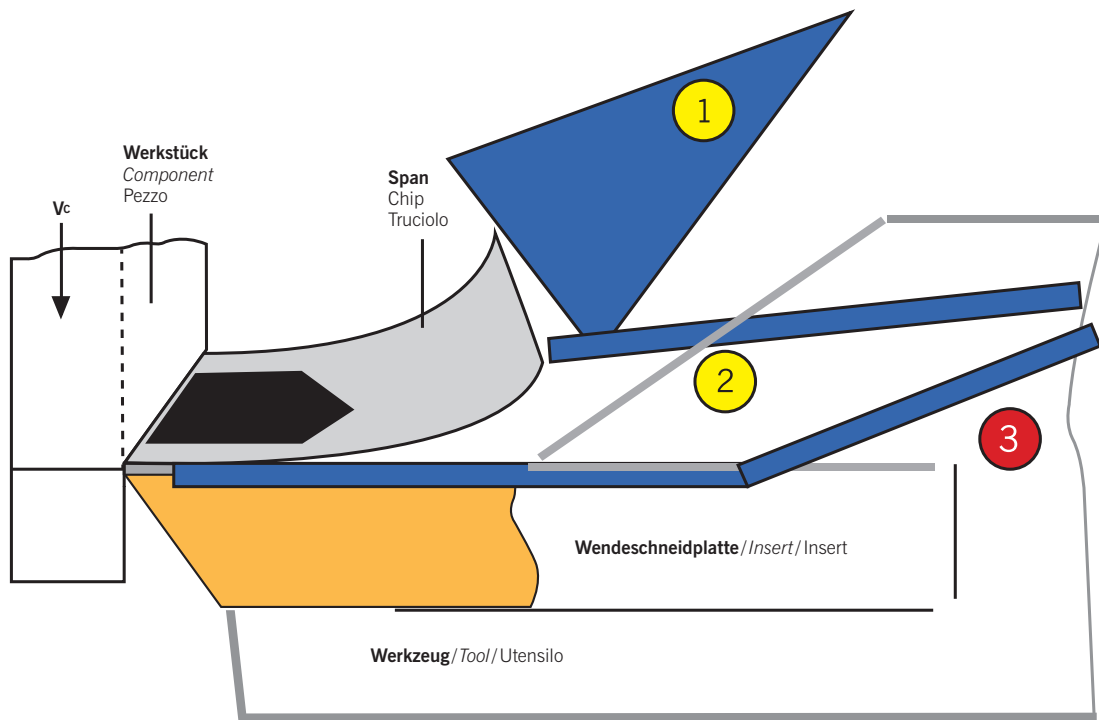

- 1 „Externe Kühlung“ über Düse/External coolant from coolant jet/Refrigerazione “estesa” dei sistemi tradizionali (su truciolo)
- 2 „Interne Kühlung“ über Halter oder Spannpratze/Through tool coolant/Refrigerazione direzionata tramite adduzioni interne classiche (su truciolo)
- 3 Neue „ACS-Kühlung“ direkt durch den Plattensitz/New ACS-coolant through the insert seat/Nuovo ACS ARNO-Cooling-System direttamente sul filo tagliente



ARNO-ACS cooling system®

Gegen zu hohe Temperaturen an der Schneide

Solving the problem of high temperatures at the cutting edge

Risolve problemi legati allo sviluppo di elevate temperature sul tagliente

2

Ohne ACS – externe Kühlung

Without ACS – external coolant

Senza ACS – refrigerazione esterna

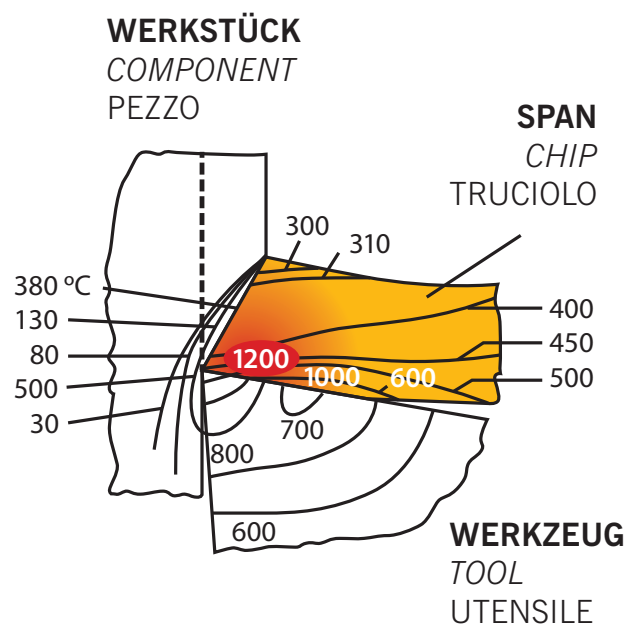
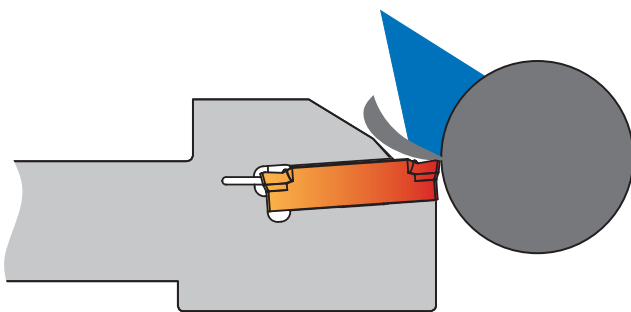

Mit dem ARNO-ACS cooling system® des SE- (Einstechen, Abstechen und Kopierdrehen) Programmes haben Sie ein Werkzeugsystem an der Hand, das gegenüber den Wettbewerbern herausragende Leistungen bietet. Als einziger Anbieter auf dem Zerspanungsmarkt, bekommen Sie bei ARNO® ein System, das den Kühlmittelstrahl direkt durch den Plattensitz leitet und so ohne Hindernisse direkt in die Schnittzone gelangt.

Vorteile:

- Höchste V_c und Vorschübe möglich
- Reduzierung der Aufbauschneidenbildung, Verringerung der Kammrissbildung durch die Vermeidung von Thermoschocks
- Kontrollierter Spanbruch
- Beste Oberflächenqualität
- Hervorragende Parallelität
- Alle Halter sind mit ihrer vernickelten Oberfläche bestens vor Korrosion geschützt
- Kein Aus- bzw. Einrichten der Kühlmitteldüsen notwendig – Reduzierung der Rüstzeit

Die zweiseitigen Schneidplatten sind für Werkzeuge mit ACS Innenkühlung in den Stechbreiten von 2 bis 6 mm und für Stechtiefen 12 und 21 mm erhältlich. Sieben Hartmetall-Sorten und sechs Spanleitstufen (teilweise bis 15° Schräge geschliffen) bieten Ihnen eine umfangreiche Auswahl für nahezu alle gängigen Werkstoffe.

Mit den passenden Abstechhaltern und Direktaufnahmen steht Ihnen ein durchgängig abgestimmtes Konzept von der Maschinenschnittstelle bis in die Schnittzone zur Verfügung.

With the ARNO-ACS cooling system® on the SE- (groove and groove turning) system we have a highly competitive solution against any competitor system. Unique to our ACS system, we offer through tool coolant directly and totally unhindered to the cutting edge.

Advantages:

- Maximum speed and feed possible
- Reduction of build up edge and thermal cracking by avoiding thermal shocks
- Well controlled chip breaking
- Superb surface finish
- Excellent flatness
- All holders are nickel plated and therefore protected against corrosion
- Reduced set-up time as there is no requirement for adjusting coolant jet

Mit ACS – Kühlung durch Unterspülung

With ACS – coolant under the swarf

Con ACS – refrigerante sotto il truciolo

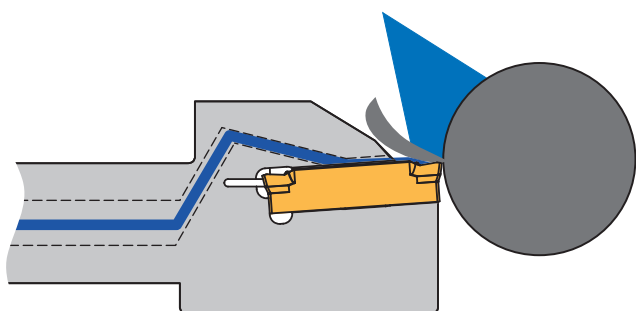

The ACS cooling system is available for double sided inserts from groove width 2 to 6mm and groove depth to 12 and 21mm. By offering 6 carbide grades and 5 chip breakers (including inserts ground with a 15° angle) we offer a solution for nearly all materials.

With the correct tool and flange mounted holder you will get the maximum performance out of your machines capability.

Il Sistema ARNO-ACS Cooling System® applicato sulla linea prodotti SE (scanalatura e scanalatura di copiatura) garantisce soluzioni di utensili dalle massime prestazioni rispetto alla concorrenza. Una soluzione tecnica unica del suo genere che raggiunge con la massima precisione il tagliente senza ostacoli, garantendo la massima efficacia di raffreddamento nella zona di taglio.

Vantaggi:

- Massimi avanzamenti e velocità di taglio
- Riduzione della formazione del tagliente di riporto
- Riduzione dell shock termico
- Migliorato controllo truciolo
- Migliorata formazione e rottura del truciolo
- Ottima finitura superficiale
- Eccellente planarità delle superfici
- Utensili nickelati resistenti alla corrosione
- Ridotti tempi di setup non avendo ugelli direzionabili

WERKSTÜCK

COMPONENT

PEZZO

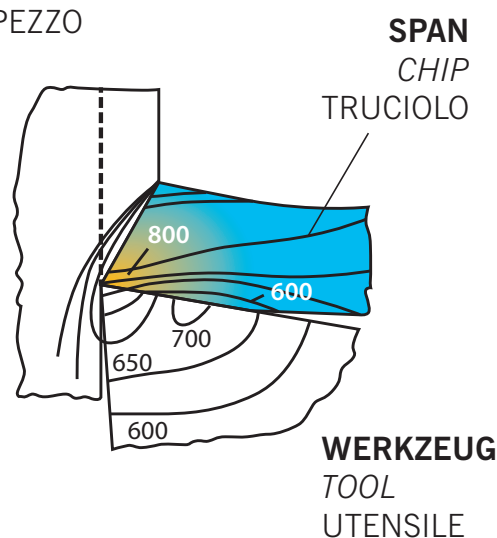

Il sistema ARNO-ACS Cooling System è disponibile con inserto bi-tagliente per larghezze di taglio da 2 a 6mm e per una profondità di 12 e 21 mm. Con 6 differenti gradi di metallo duro e 5 diverse geometrie di rompitrucciolo (più varianti con angoli frontali fino a 15°) offriamo una soluzione alla lavorazione di tutti i materiali.

Con la giusta composizione di utensile ed attacco diretto sulla torretta si ottiene il sistema più rigido, compatto e performante per la desiderata operazione di taglio.

2



Monoblockhalter ACS1 (HSE) / Monoblock holders ACS1 (HSE) / Utensili monoblocco ACS1(HSE)

Seite/Page/Pagina **162 – 174**



Seite/Page/Pagina **166 / 175**



KMH-Werkzeughalter (VDI) Form B + C für Monoblockhalter mit ACS / KMH-holders (VDI) form B + C with monoblock holders and modules with ACS / Adattatore KMH (VDI) Forma B + C per utensili monoblocco con ACS

Seite/Page/Pagina **178 – 183**



SE Schneideinsätze / SE Inserts / SE Inserti

Seite/Page/Pagina **186 – 187**

Monoblockhalter / Monoblock holders / Utensili monoblocco



2

HSE	2020L	SE	2403	ET21	ACS1	H1
H = Halter Holder Corpo	Schaftgröße 20x20 mm Linke Ausführung	Schneideinsatz Insert Inserto	Plattenmaße Insert sizes Dimensioni inserto	Einstechtiefe ET = 12 mm oder 21 mm	ARNO-ACS cooling system® ACS1 = mit einem Kühlkanal ACS1 = with one coolant hole ACS1 = con un canale refrigerante	Anschluss Connection Raccordo
S = Stechen Grooving Troncatura	Shank size version 20x20 mm L = Left-hand	Einstechen External Grooving Scanalatura	24 – Plattenlänge 24 mm Insert length 24 mm Lunghezza inserto 24 mm	Part-off diameter 12 mm or 21 mm Profondità gola 12 mm o 21 mm		H = Anschluss von hinten connection from rear of the tool raccordo posteriore
A = Außen External Esterna	Dimensione versione 20 x 20 mm L = Sinistro		03 – Einstechbreite EB = 3 mm Groove width EB = 3 mm Larghezza gola EB = 3 mm			S = Anschluss von der Seite connection from side of the tool raccordo laterale
						UN = Anschluss von unten (Nut) connection from below (slot) asola su piano di appoggio

Schneideinsätze / Inserts / Inserti



SE24	30	03	N	M2	AP	5020
SA = Einstechen External Grooving Scanalatura	Einstechbreite EB = 3 mm Groove width EB = 3 mm	Eckenradius R = 0,3 mm Corner radius R = 0.3 mm	N = Neutral Neutral Neutro	Geometrie Geometry Geometria	ARNO®-Einsatzgebiet ARNO®-Application area ARNO®-Campo utilizzo	Schneidstoffcode (ISO-Gruppierung) Grade code (ISO) Qualità (ISO)
24 = Plattenlänge Insert length Lunghezza inserto	Larghezza gola EB = 3 mm	Raggio R = 0,3 mm	R = Rechts Right-hand Destro			
			L = Links Left-hand Sinistro			

HSE

Monoblockhalter (ET=12 mm) / Monoblock holder (ET=12 mm) /
Utensile monoblocco (ET=12 mm)

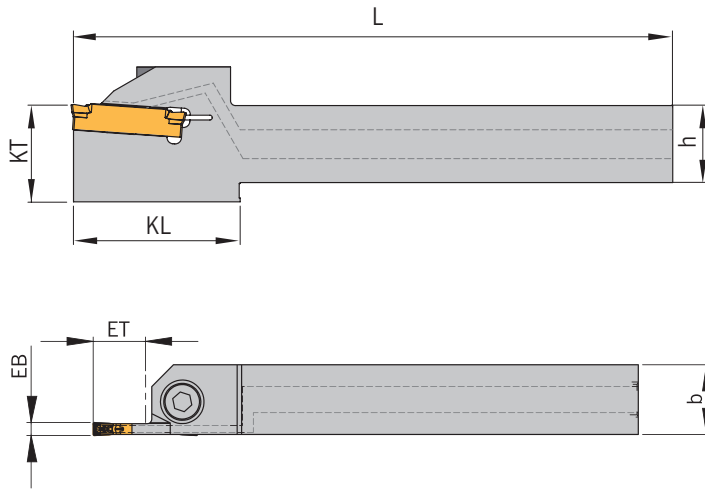
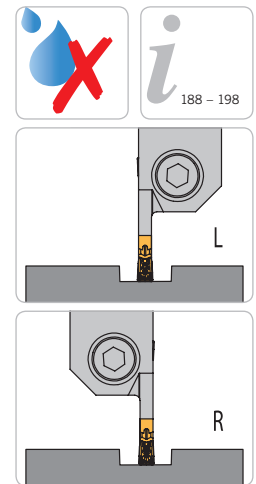

Rechte Ausführung abgebildet
Right-hand execution shown
Versione destra in figura

N NEU/NEW/
NUOVO

Trägerwerkzeuge / Holders / Utensili

Bezeichnung Designation Articolo	EB	ET	h	b	L	KL	KT	PG 25	Schneideinsatz Insert Inserto
HSE 1616L/R-SE2402-ET12	2	12	16	16	125	35	20	●	SE 24-20...
HSE 1616L/R-SE2403-ET12	3	12	16	16	125	35	20	●	SE 24-30...
HSE 1616L/R-SE2404-ET12	4	12	16	16	125	35	20	●	SE 24-40...
HSE 2020L/R-SE2402-ET12	2	12	20	20	125	-	-	●	SE 24-20...
HSE 2020L/R-SE2403-ET12	3	12	20	20	125	-	-	●	SE 24-30...
HSE 2020L/R-SE2404-ET12	4	12	20	20	125	-	-	●	SE 24-40...
HSE 2020L/R-SE2405-ET12	5	12	20	20	125	-	-	●	SE 24-50...
HSE 2020L/R-SE2406-ET12	6	12	20	20	125	-	-	●	SE 24-60...
HSE 2525L/R-SE2403-ET12	3	12	25	25	150	-	-	●	SE 24-30...
HSE 2525L/R-SE2404-ET12	4	12	25	25	150	-	-	●	SE 24-40...
HSE 2525L/R-SE2405-ET12	5	12	25	25	150	-	-	●	SE 24-50...
HSE 2525L/R-SE2406-ET12	6	12	25	25	150	-	-	●	SE 24-60...

Ersatzteile / Spare Parts / Ricambi

Trägerwerkzeug Holder Utensile	Schraube Screw Vite	Schlüssel Key Chiave
HSE 1616.. HSE 2525.. -SE24.. ET12	DIN912 M5X16-12.9	KP 1321

HSE

Monoblockhalter (ET=21 mm) / Monoblock holder (ET=21 mm) /
Utensile monoblocco (ET=21 mm)

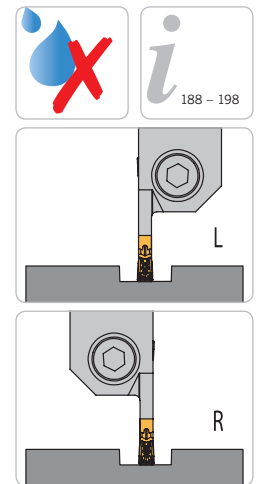
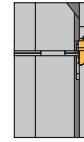
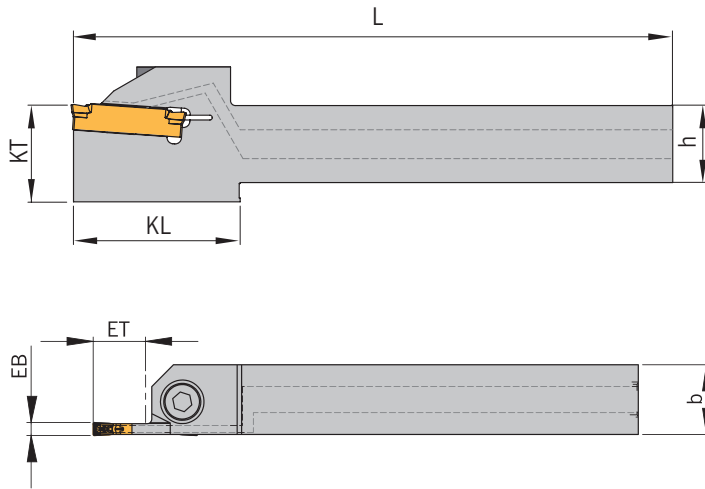

Rechte Ausführung abgebildet
Right-hand execution shown
Versione destra in figura



Trägerwerkzeuge / Holders / Utensili

Bezeichnung Designation Articolo	EB	ET	h	b	L	KL	KT	PG 25	Schneideinsatz Insert Inserto
HSE 1616L/R-SE2402-ET21	2	21	16	16	125	44	20	●	SE 24-20...
HSE 1616L/R-SE2403-ET21	3	21	16	16	125	44	20	●	SE 24-30...
HSE 1616L/R-SE2404-ET21	4	21	16	16	125	44	20	●	SE 24-40...
HSE 2020L/R-SE2402-ET21	2	21	20	20	125	-	-	●	SE 24-20...
HSE 2020L/R-SE2403-ET21	3	21	20	20	125	-	-	●	SE 24-30...
HSE 2020L/R-SE2404-ET21	4	21	20	20	125	-	-	●	SE 24-40...
HSE 2020L/R-SE2405-ET21	5	21	20	20	125	-	-	●	SE 24-50...
HSE 2020L/R-SE2406-ET21	6	21	20	20	125	-	-	●	SE 24-60...
HSE 2525L/R-SE2403-ET21	3	21	25	25	150	-	-	●	SE 24-30...
HSE 2525L/R-SE2404-ET21	4	21	25	25	150	-	-	●	SE 24-40...
HSE 2525L/R-SE2405-ET21	5	21	25	25	150	-	-	●	SE 24-50...
HSE 2525L/R-SE2406-ET21	6	21	25	25	150	-	-	●	SE 24-60...

Ersatzteile / Spare Parts / Ricambi

Trägerwerkzeug Holder Utensile	Schraube Screw Vite	Schlüssel Key Chiave
HSE 1616.. HSE 2525.. -SE24.. ET21	DIN912 M5X16-12.9	KP 1321

HSE-S-ACS1-S.G

Monoblockhalter mit Innenkühlung ACS1 von der Seite (ET=12 mm) - für Langdrehautomaten / Monoblock holder with through tool coolant (ACS1) access from the side (ET=12 mm) - for swiss type machines / Utensile monoblocco con adduzione interna ACS1 laterale (ET=12 mm) - per fantina mobile

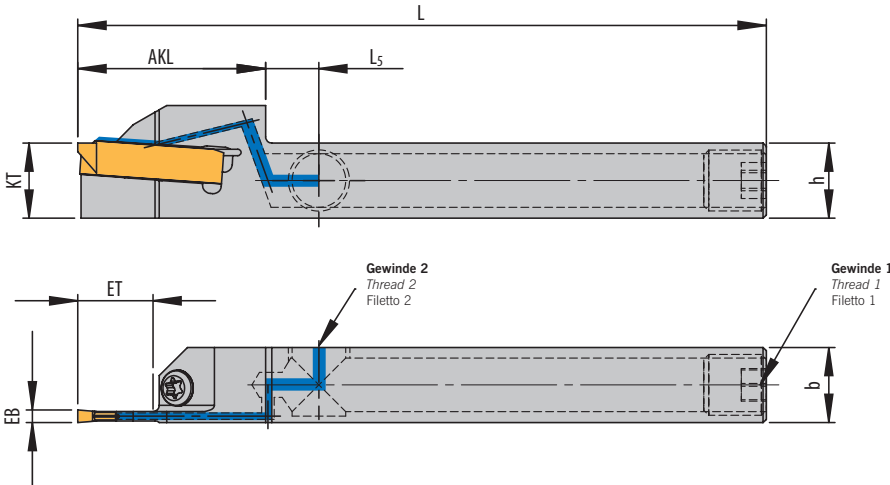
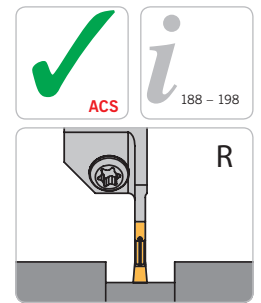

Rechte Ausführung abgebildet
Right-hand execution shown
Versione destra in figura

Trägerwerkzeuge / Holders / Utensili

Bezeichnung Designation Articolo	EB	ET	h	b	L	L ₅	AKL	KT	Gewinde 1 Thread 1 Filetto 1	Gewinde 2 Thread 2 Filetto 2	PG 25	Schneideinsatz Insert Inserto
HSE 1212S-R-SE2402-ET12-ACS1-H2-S2G	2	12	12	12	110	8,5	30	12	G 1/8"	G 1/8"	●	SE 24-20...
HSE 1212S-R-SE2403-ET12-ACS1-H2-S2G	3	12	12	12	110	8,5	30	12	G 1/8"	G 1/8"	●	SE 24-30...
HSE 1616S-R-SE2402-ET12-ACS1-H2-S2G	2	12	16	16	110	8,5	30	16	G 1/8"	G 1/8"	●	SE 24-20...
HSE 1616S-R-SE2403-ET12-ACS1-H2-S2G	3	12	16	16	110	8,5	30	16	G 1/8"	G 1/8"	●	SE 24-30...

Ersatzteile / Spare Parts / Ricambi

Trägerwerkzeug Holder Utensile	Schraube Screw Vite	Schlüssel Key Chiave
HSE 1212S..HSE 1616S..-SE24..ET..ACS1..	AS 0022	T5215-IP

Zubehör / Accessories / Accessori

Bezeichnung Designation Articolo	A	B
KA 001 Kühlmittelanschluss – gerade Coolant supply – straight Raccordo – dritto	M8x1	Ø 6 mm
KA 002	1/8"	Ø 6 mm
KA 003	1/4"	Ø 10 mm
KA 004 Kühlmittelanschluss – winklig, fest Coolant supply – angled and fixed Raccordo – angolato	M8x1	Ø 6 mm
KA 005	1/8"	Ø 6 mm
KA 006 Schwenkverschraubung Swivelling screw-fitting Raccordo – orientabile	M8x1	Ø 6 mm
KA 007	1/8"	Ø 6 mm
KA 008	1/4"	Ø 10 mm

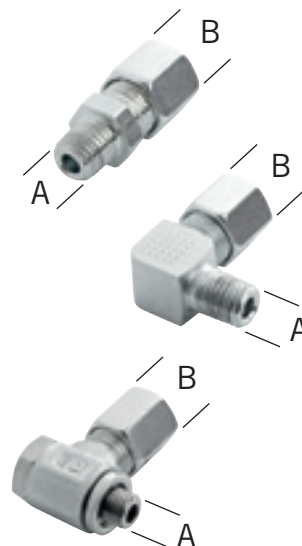

HSE-UD-ACS1-S

Monoblockhalter mit Innenkühlung ACS1 von der Seite (ET=12 mm) - mit Spannung von oben und unten / Monoblock holder with through tool coolant (ACS1) access from the side (ET=12 mm) - Locking from top and bottom / Utensile monoblocco con adduzione interna ACS1 laterale (ET=12 mm) - Bloccaggio da sopra e sotto

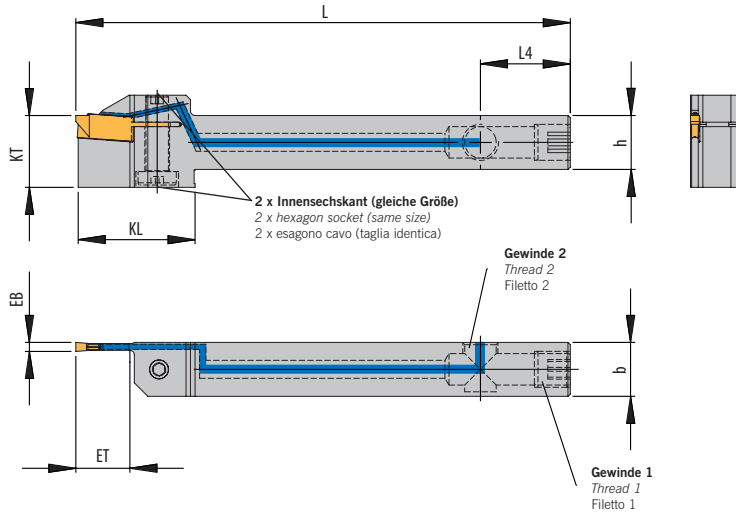
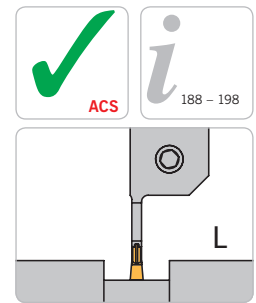

Linke Ausführung abgebildet
Left-hand execution shown
Versione sinistra in figura

Trägerwerkzeuge / Holders / Utensili

Ausführung S1 = Gewinde 1: M8x1, Gewinde 2: M8x1 / Execution S1 = Thread 1 M8x1, Thread 2 M8x1 / Esecuzione S1 = filetto 1 M8x1, filetto 2 M8x1

Bezeichnung Designation Articolo	EB	ET	h	b	L	L ₄	KL	KT	Gewinde 1 Thread 1 Filetto 1	Gewinde 2 Thread 2 Filetto 2	PG 25	Schneideinsatz Insert Inserto
HSE 1212UD-L-SE2402-ET12-ACS1-S1	2	12	12	12	110	20	26	16	M8x1	M8x1	●	SE 24-20...
HSE 1212UD-L-SE2403-ET12-ACS1-S1	3	12	12	12	110	20	26	16	M8x1	M8x1	●	SE 24-30...

Ausführung S2 = Gewinde 1: M8x1, Gewinde 2: G1/8" / Execution S2 = Thread 1: M8x1, Thread 2: G1/8" / Esecuzione S2 = filetto 1: M8x1, filetto 2: G1/8"

Bezeichnung Designation Articolo	EB	ET	h	b	L	L ₄	KL	KT	Gewinde 1 Thread 1 Filetto 1	Gewinde 2 Thread 2 Filetto 2	PG 25	Schneideinsatz Insert Inserto
HSE 1212UD-L-SE2402-ET12-ACS1-S2	2	12	12	12	110	20	26	16	M8x1	G 1/8"	●	SE 24-20...
HSE 1212UD-L-SE2403-ET12-ACS1-S2	3	12	12	12	110	20	26	16	M8x1	G 1/8"	●	SE 24-30...

Ersatzteile / Spare Parts / Ricambi

Trägerwerkzeug Holder Utensile	Schraube Screw Vite	Schlüssel Key Chiave
HSE 1212UD..-SE24..ACS1..	AS 0084	KP 3111

Kühlmittelanschlüsse finden Sie auf Seite 164
Coolant supply can be found on page 164
Raccordo vedere pagina 164



Diese Monoblockhalter bekommen Sie mit Ihren spezifischen Kühlan schlüssen. Ein Anfrageblatt hierzu finden Sie auf Seite 166 oder im Internet unter: www.arno.de/service/downloads
The coolant inlet can be supplied to your specification, please complete enquiry sheet on page 166 or download this from: www.arno.de/service/downloads
Questi corpi utensile sono fornibili con specifiche connessioni del refrigerante, Vedere modulo richiesta a Pag. 166 o download del modulo da: www.arno.de/service/downloads

Monoblockhalter mit Innenkühlung ACS1 von hinten und Spannung von oben und unten



Diese Halter fertigen wir Ihnen zum Preis des Standardwerkzeuges.

2

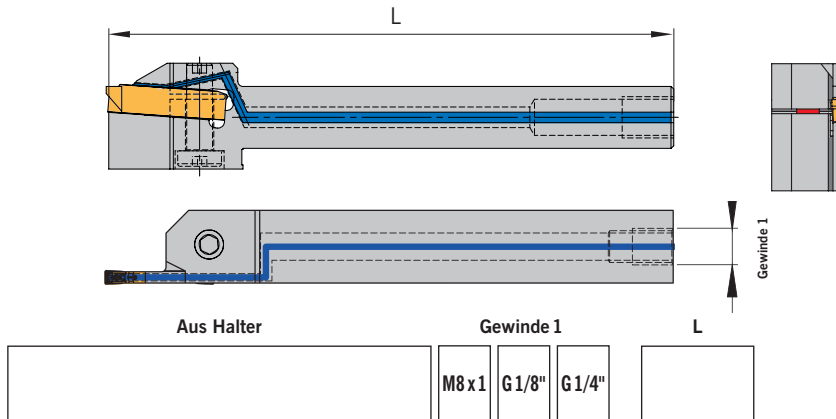

Monoblockhalter mit Innenkühlung ACS1 von der Seite und Spannung von oben und unten

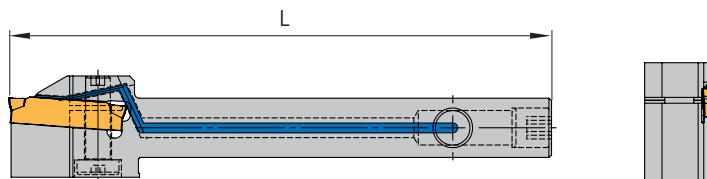

Ausführung S1. – Das Gewinde 2 ist auf der gleichen Seite wie die Schneide

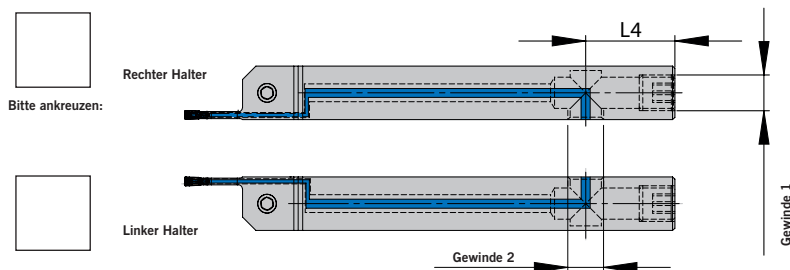

Ausführung S1G. – Das Gewinde 2 ist gegenüber der Schneide

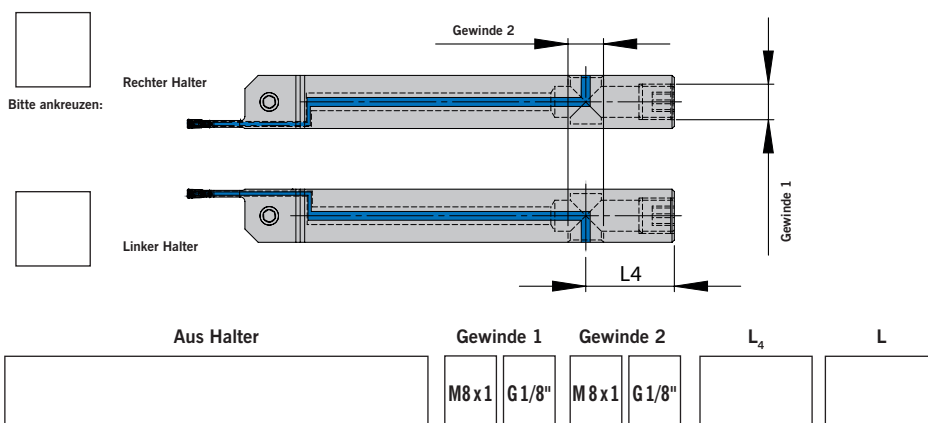

Download dieses Formulars unter: www.arno.de/service/downloads

Monoblock holder with through tool coolant access and locking from top and bottom

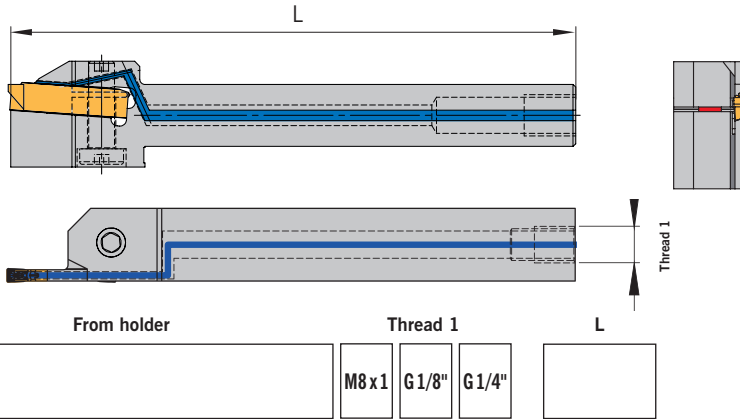

This tool we produce to the price of the standard tool.

2

Monoblock holder with through tool coolant access from the side and locking from top and bottom

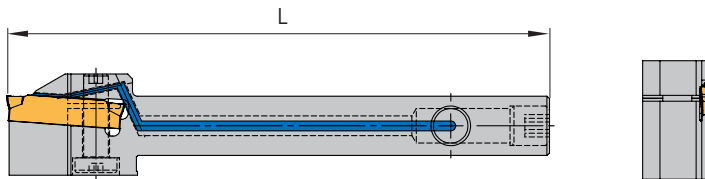

Design S1. – Thread 2 is on the same side as the cutting edge

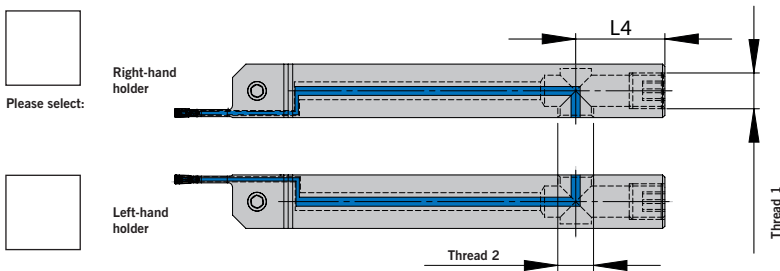

Design S1G. – Thread 2 is on the opposite side of the cutting edge

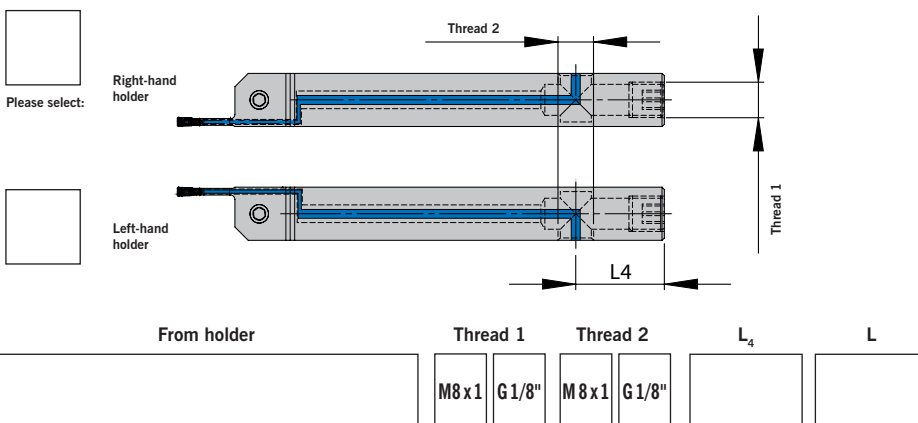

Download this form from: www.arno.de/service/downloads

Utensile monoblocco con adduzione interna ACS1 posteriore e bloccaggio da sopra e sotto

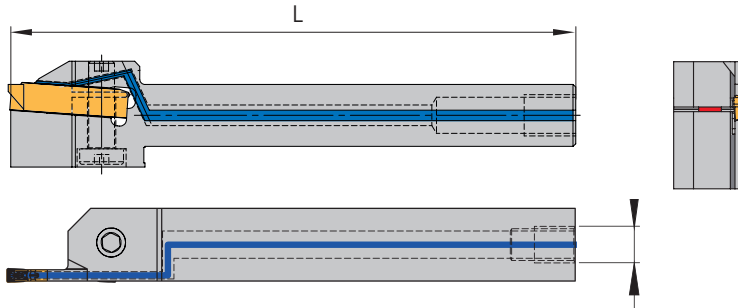

Ricavare da utensile Filetto 1 L

	M8x1	G1/8"	G1/4"	L
--	------	-------	-------	---

Questi utensili vengono realizzati al prezzo dello standard.

Utensile monoblocco con adduzione interna ACS1 laterale e bloccaggio da sopra e sotto

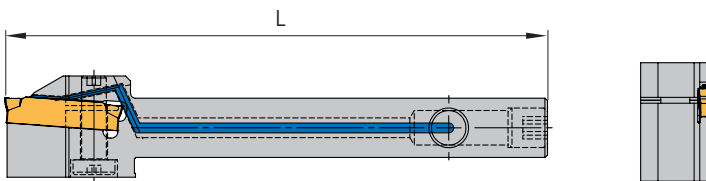

Versione S1. – Filettatura 2 sul medesimo lato dell'inserto

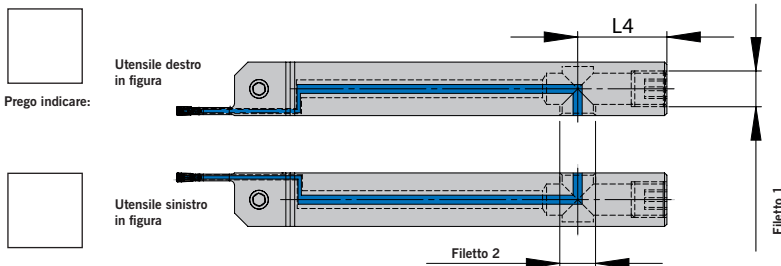

Versione S1G. – Filettatura 2 sul lato opposto l'inserto

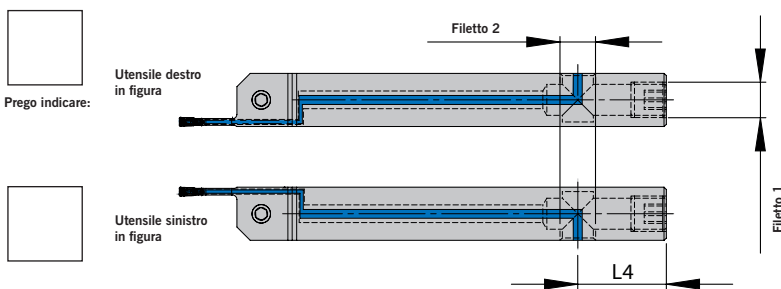

Ricavare da utensile Filetto 1 Filetto 2 L₄ L

	M8x1	G1/8"	M8x1	G1/8"	L ₄	L
--	------	-------	------	-------	----------------	---

Download del modulo da: www.arno.de/service/downloads

HSE-ACS1-S

Monoblockhalter mit Innenkühlung ACS1 von der Seite (ET=12 mm)

Monoblock holder with through tool coolant (ACS1) access from the side (ET=12 mm)

Utensile monoblocco con adduzione interna ACS1 laterale (ET=12 mm)

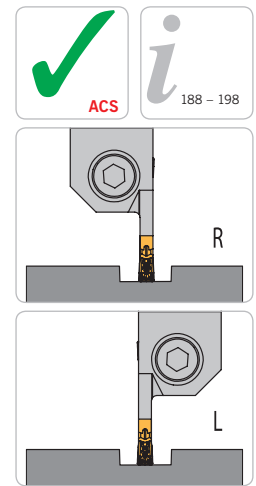
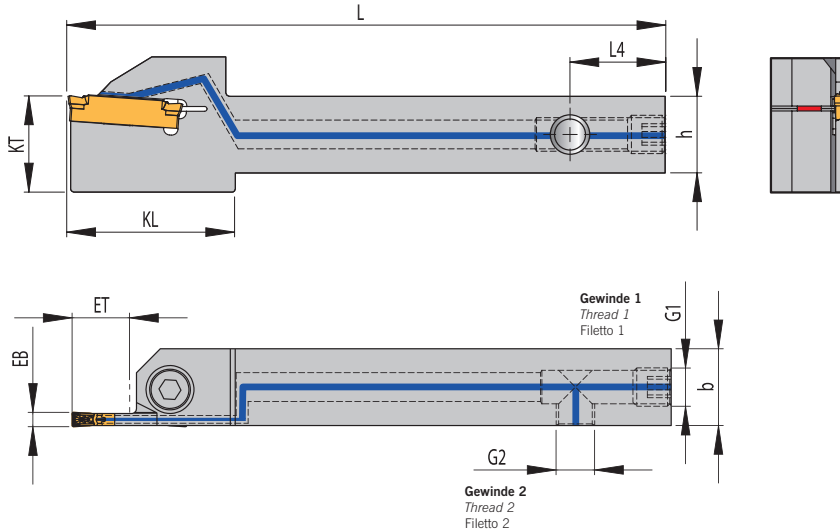

Rechte Ausführung abgebildet
Right-hand execution shown
Versione destra in figura

Trägerwerkzeuge / Holders / Utensili

Ausführung S1 = Gewinde 1: M8x1, Gewinde 2: M8x1 / Execution S1 = Thread 1 M8x1, Thread 2 M8x1 /
Esecuzione S1 = filetto 1 M8x1, filetto 2 M8x1

Bezeichnung Designation Articolo	EB	ET	h	b	L	L ₄	KL	KT	Gewinde 1 Thread 1 Filetto 1	Gewinde 2 Thread 2 Filetto 2	PG 25	Schneideinsatz Insert Inserto
HSE 1616L/R-SE2402-ET12-ACS1-S1	2	12	16	16	125	20	35	20	M8x1	M8x1	●	SE 24-20...
HSE 1616L/R-SE2403-ET12-ACS1-S1	3	12	16	16	125	20	35	20	M8x1	M8x1	●	SE 24-30...
HSE 1616L/R-SE2404-ET12-ACS1-S1	4	12	16	16	125	20	35	20	M8x1	M8x1	●	SE 24-40...
HSE 2020L/R-SE2402-ET12-ACS1-S1	2	12	20	20	125	20	-	-	M8x1	M8x1	●	SE 24-20...
HSE 2020L/R-SE2403-ET12-ACS1-S1	3	12	20	20	125	20	-	-	M8x1	M8x1	●	SE 24-30...
HSE 2020L/R-SE2404-ET12-ACS1-S1	4	12	20	20	125	20	-	-	M8x1	M8x1	●	SE 24-40...
HSE 2020L/R-SE2405-ET12-ACS1-S1	5	12	20	20	125	20	-	-	M8x1	M8x1	●	SE 24-50...
HSE 2020L/R-SE2406-ET12-ACS1-S1	6	12	20	20	125	20	-	-	M8x1	M8x1	●	SE 24-60...
HSE 2525L/R-SE2403-ET12-ACS1-S1	3	12	25	25	150	20	-	-	M8x1	M8x1	●	SE 24-30...
HSE 2525L/R-SE2404-ET12-ACS1-S1	4	12	25	25	150	20	-	-	M8x1	M8x1	●	SE 24-40...
HSE 2525L/R-SE2405-ET12-ACS1-S1	5	12	25	25	150	20	-	-	M8x1	M8x1	●	SE 24-50...
HSE 2525L/R-SE2406-ET12-ACS1-S1	6	12	25	25	150	20	-	-	M8x1	M8x1	●	SE 24-60...

Ausführung S2 = Gewinde 1: M8x1, Gewinde 2: G1/8" / Execution S2 = Thread 1: M8x1, Thread 2: G1/8" /
Esecuzione S2 = filetto 1: M8x1, filetto 2: G1/8"

Bezeichnung Designation Articolo	EB	ET	h	b	L	L ₄	KL	KT	Gewinde 1 Thread 1 Filetto 1	Gewinde 2 Thread 2 Filetto 2	PG 25	Schneideinsatz Insert Inserto
HSE 1616L/R-SE2402-ET12-ACS1-S2	2	12	16	16	125	20	35	20	M8x1	G 1/8"	●	SE 24-20...
HSE 1616L/R-SE2403-ET12-ACS1-S2	3	12	16	16	125	20	35	20	M8x1	G 1/8"	●	SE 24-30...
HSE 1616L/R-SE2404-ET12-ACS1-S2	4	12	16	16	125	20	35	20	M8x1	G 1/8"	●	SE 24-40...
HSE 2020L/R-SE2402-ET12-ACS1-S2	2	12	20	20	125	20	-	-	M8x1	G 1/8"	●	SE 24-20...
HSE 2020L/R-SE2403-ET12-ACS1-S2	3	12	20	20	125	20	-	-	M8x1	G 1/8"	●	SE 24-30...
HSE 2020L/R-SE2404-ET12-ACS1-S2	4	12	20	20	125	20	-	-	M8x1	G 1/8"	●	SE 24-40...
HSE 2020L/R-SE2405-ET12-ACS1-S2	5	12	20	20	125	20	-	-	M8x1	G 1/8"	●	SE 24-50...
HSE 2020L/R-SE2406-ET12-ACS1-S2	6	12	20	20	125	20	-	-	M8x1	G 1/8"	●	SE 24-60...
HSE 2525L/R-SE2403-ET12-ACS1-S2	3	12	25	25	150	20	-	-	M8x1	G 1/8"	●	SE 24-30...
HSE 2525L/R-SE2404-ET12-ACS1-S2	4	12	25	25	150	20	-	-	M8x1	G 1/8"	●	SE 24-40...
HSE 2525L/R-SE2405-ET12-ACS1-S2	5	12	25	25	150	20	-	-	M8x1	G 1/8"	●	SE 24-50...
HSE 2525L/R-SE2406-ET12-ACS1-S2	6	12	25	25	150	20	-	-	M8x1	G 1/8"	●	SE 24-60...

Ersatzteile / Spare Parts / Ricambi

Trägerwerkzeug Holder Utensile	Schraube Screw Vite	Schlüssel Key Chiave
HSE 1616...HSE 2525... -SE24...ET...ACS1..	DIN912 M5X16-12.9	KP 1321

Kühlmittelanschlüsse finden Sie auf Seite 164

Coolant supply can be found on page 164

Raccordo vedere pagina 164

HSE-ACS1-S

Monoblockhalter mit Innenkühlung ACS1 von der Seite (ET=21 mm)

Monoblock holder with through tool coolant (ACS1) access from the side (ET=21 mm)

Utensile monoblocco con adduzione interna ACS1 laterale (ET=21 mm)

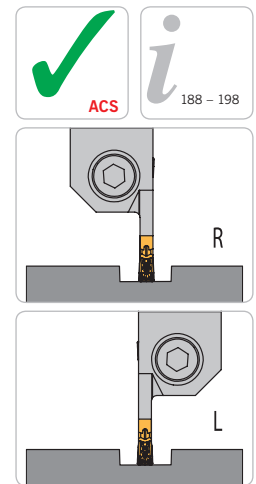
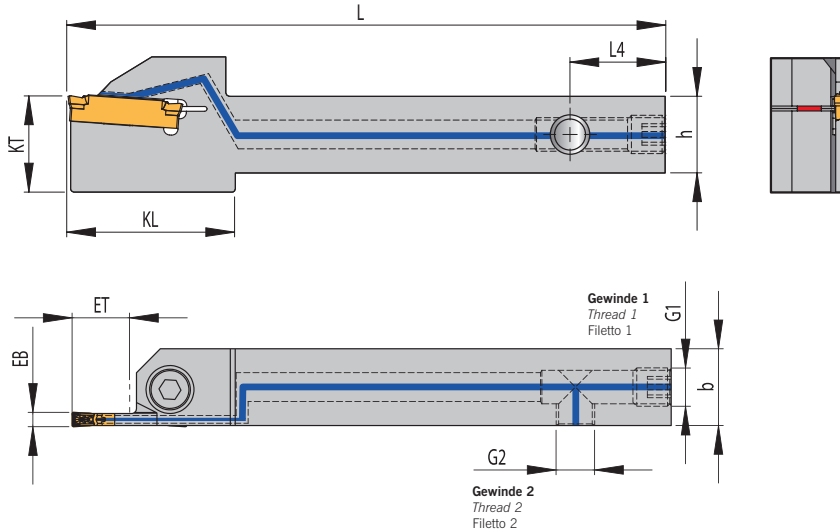

Rechte Ausführung abgebildet
Right-hand execution shown
Versione destra in figura

Trägerwerkzeuge / Holders / Utensili

Ausführung S1 = Gewinde 1: M8x1, Gewinde 2: M8x1 / Execution S1 = Thread 1 M8x1, Thread 2 M8x1 /
Esecuzione S1 = filetto 1 M8x1, filetto 2 M8x1

Bezeichnung Designation Articolo	EB	ET	h	b	L	L ₄	KL	KT	Gewinde 1 Thread 1 Filetto 1	Gewinde 2 Thread 2 Filetto 2	PG 25	Schneideinsatz Insert Inserto
HSE 1616L/R-SE2402-ET21-ACS1-S1	2	21	16	16	125	20	44	20	M8x1	M8x1	●	SE 24-20...
HSE 1616L/R-SE2403-ET21-ACS1-S1	3	21	16	16	125	20	44	20	M8x1	M8x1	●	SE 24-30...
HSE 1616L/R-SE2404-ET21-ACS1-S1	4	21	16	16	125	20	44	20	M8x1	M8x1	●	SE 24-40...
HSE 2020L/R-SE2402-ET21-ACS1-S1	2	21	20	20	125	20	-	-	M8x1	M8x1	●	SE 24-20...
HSE 2020L/R-SE2403-ET21-ACS1-S1	3	21	20	20	125	20	-	-	M8x1	M8x1	●	SE 24-30...
HSE 2020L/R-SE2404-ET21-ACS1-S1	4	21	20	20	125	20	-	-	M8x1	M8x1	●	SE 24-40...
HSE 2020L/R-SE2405-ET21-ACS1-S1	5	21	20	20	125	20	-	-	M8x1	M8x1	●	SE 24-50...
HSE 2020L/R-SE2406-ET21-ACS1-S1	6	21	20	20	125	20	-	-	M8x1	M8x1	●	SE 24-60...
HSE 2525L/R-SE2403-ET21-ACS1-S1	3	21	25	25	150	20	-	-	M8x1	M8x1	●	SE 24-30...
HSE 2525L/R-SE2404-ET21-ACS1-S1	4	21	25	25	150	20	-	-	M8x1	M8x1	●	SE 24-40...
HSE 2525L/R-SE2405-ET21-ACS1-S1	5	21	25	25	150	20	-	-	M8x1	M8x1	●	SE 24-50...
HSE 2525L/R-SE2406-ET21-ACS1-S1	6	21	25	25	150	20	-	-	M8x1	M8x1	●	SE 24-60...

Ausführung S2 = Gewinde 1: M8x1, Gewinde 2: G1/8" / Execution S2 = Thread 1: M8x1, Thread 2: G1/8" /
Esecuzione S2 = filetto 1: M8x1, filetto 2: G1/8"

Bezeichnung Designation Articolo	EB	ET	h	b	L	L ₄	KL	KT	Gewinde 1 Thread 1 Filetto 1	Gewinde 2 Thread 2 Filetto 2	PG 25	Schneideinsatz Insert Inserto
HSE 1616L/R-SE2402-ET21-ACS1-S2	2	21	16	16	125	20	44	20	M8x1	G 1/8"	●	SE 24-20...
HSE 1616L/R-SE2403-ET21-ACS1-S2	3	21	16	16	125	20	44	20	M8x1	G 1/8"	●	SE 24-30...
HSE 1616L/R-SE2404-ET21-ACS1-S2	4	21	16	16	125	20	44	20	M8x1	G 1/8"	●	SE 24-40...
HSE 2020L/R-SE2402-ET21-ACS1-S2	2	21	20	20	125	20	-	-	M8x1	G 1/8"	●	SE 24-20...
HSE 2020L/R-SE2403-ET21-ACS1-S2	3	21	20	20	125	20	-	-	M8x1	G 1/8"	●	SE 24-30...
HSE 2020L/R-SE2404-ET21-ACS1-S2	4	21	20	20	125	20	-	-	M8x1	G 1/8"	●	SE 24-40...
HSE 2020L/R-SE2405-ET21-ACS1-S2	5	21	20	20	125	20	-	-	M8x1	G 1/8"	●	SE 24-50...
HSE 2020L/R-SE2406-ET21-ACS1-S2	6	21	20	20	125	20	-	-	M8x1	G 1/8"	●	SE 24-60...
HSE 2525L/R-SE2403-ET21-ACS1-S2	3	21	25	25	150	20	-	-	M8x1	G 1/8"	●	SE 24-30...
HSE 2525L/R-SE2404-ET21-ACS1-S2	4	21	25	25	150	20	-	-	M8x1	G 1/8"	●	SE 24-40...
HSE 2525L/R-SE2405-ET21-ACS1-S2	5	21	25	25	150	20	-	-	M8x1	G 1/8"	●	SE 24-50...
HSE 2525L/R-SE2406-ET21-ACS1-S2	6	21	25	25	150	20	-	-	M8x1	G 1/8"	●	SE 24-60...

Ersatzteile / Spare Parts / Ricambi

Trägerwerkzeug Holder Utensile	Schraube Screw Vite	Schlüssel Key Chiave
HSE 1616...HSE 2525... -SE24...ET...ACS1..	DIN912 M5X16-12.9	KP 1321

Kühlmittelanschlüsse finden Sie auf Seite 164

Coolant supply can be found on page 164

Raccordo vedere pagina 164

HSE-ACS1-H

Monoblockhalter mit Innenkühlung ACS1 von hinten (ET=12 mm)

Monoblock holder with through tool coolant (ACS1) access from the back (ET=12 mm)

Utensile monoblocco con adduzione interna ACS1 posteriore (ET=12 mm)

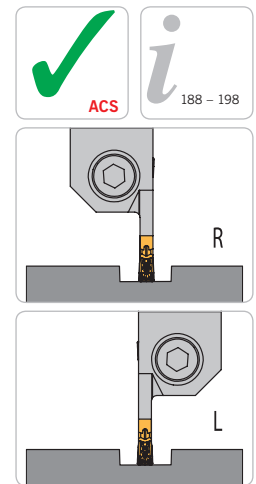
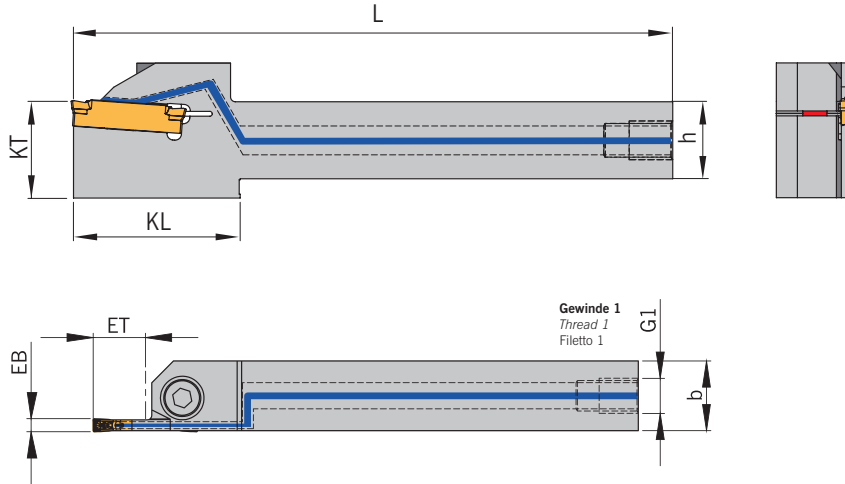

Rechte Ausführung abgebildet
Right-hand execution shown
Versione destra in figura

Trägerwerkzeuge / Holders / Utensili

Ausführung H1 = Gewinde M8x1 / Execution H1 = Thread M8x1 / Esecuzione H1 = filetto M8x1

Bezeichnung Designation Articolo	EB	ET	h	b	L	KL	KT	Gewinde 1 Thread 1 Filetto 1	PG 25	Schneideinsatz Insert Inserto
HSE 1616L/R-SE2402-ET12-ACS1-H1	2	12	16	16	125	35	20	M8x1	●	SE 24-20...
HSE 1616L/R-SE2403-ET12-ACS1-H1	3	12	16	16	125	35	20	M8x1	●	SE 24-30...
HSE 1616L/R-SE2404-ET12-ACS1-H1	4	12	16	16	125	35	20	M8x1	●	SE 24-40...
HSE 2020L/R-SE2402-ET12-ACS1-H1	2	12	20	20	125	-	-	M8x1	●	SE 24-20...
HSE 2020L/R-SE2403-ET12-ACS1-H1	3	12	20	20	125	-	-	M8x1	●	SE 24-30...
HSE 2020L/R-SE2404-ET12-ACS1-H1	4	12	20	20	125	-	-	M8x1	●	SE 24-40...
HSE 2020L/R-SE2405-ET12-ACS1-H1	5	12	20	20	125	-	-	M8x1	●	SE 24-50...
HSE 2020L/R-SE2406-ET12-ACS1-H1	6	12	20	20	125	-	-	M8x1	●	SE 24-60...
HSE 2525L/R-SE2403-ET12-ACS1-H1	3	12	25	25	150	-	-	M8x1	●	SE 24-30...
HSE 2525L/R-SE2404-ET12-ACS1-H1	4	12	25	25	150	-	-	M8x1	●	SE 24-40...
HSE 2525L/R-SE2405-ET12-ACS1-H1	5	12	25	25	150	-	-	M8x1	●	SE 24-50...
HSE 2525L/R-SE2406-ET12-ACS1-H1	6	12	25	25	150	-	-	M8x1	●	SE 24-60...

Hinweis: Zubehör muss separat bestellt werden.

Remark: Accessories must be ordered separately.

Nota: Gli accessori devono essere ordinati separatamente.

Ausführung H2 = Gewinde G1/8" / Execution H2 = Thread G1/8" / Esecuzione H2 = filetto G1/8"

Bezeichnung Designation Articolo	EB	ET	h	b	L	KL	KT	Gewinde 1 Thread 1 Filetto 1	PG 25	Schneideinsatz Insert Inserto
HSE 1616L/R-SE2402-ET12-ACS1-H2	2	12	16	16	125	35	20	G 1/8"	●	SE 24-20...
HSE 1616L/R-SE2403-ET12-ACS1-H2	3	12	16	16	125	35	20	G 1/8"	●	SE 24-30...
HSE 1616L/R-SE2404-ET12-ACS1-H2	4	12	16	16	125	35	20	G 1/8"	●	SE 24-40...
HSE 2020L/R-SE2402-ET12-ACS1-H2	2	12	20	20	125	-	-	G 1/8"	●	SE 24-20...
HSE 2020L/R-SE2403-ET12-ACS1-H2	3	12	20	20	125	-	-	G 1/8"	●	SE 24-30...
HSE 2020L/R-SE2404-ET12-ACS1-H2	4	12	20	20	125	-	-	G 1/8"	●	SE 24-40...
HSE 2020L/R-SE2405-ET12-ACS1-H2	5	12	20	20	125	-	-	G 1/8"	●	SE 24-50...
HSE 2020L/R-SE2406-ET12-ACS1-H2	6	12	20	20	125	-	-	G 1/8"	●	SE 24-60...
HSE 2525L/R-SE2403-ET12-ACS1-H2	3	12	25	25	150	-	-	G 1/8"	●	SE 24-30...
HSE 2525L/R-SE2404-ET12-ACS1-H2	4	12	25	25	150	-	-	G 1/8"	●	SE 24-40...
HSE 2525L/R-SE2405-ET12-ACS1-H2	5	12	25	25	150	-	-	G 1/8"	●	SE 24-50...
HSE 2525L/R-SE2406-ET12-ACS1-H2	6	12	25	25	150	-	-	G 1/8"	●	SE 24-60...

Hinweis: Zubehör muss separat bestellt werden.

Remark: Accessories must be ordered separately.

Nota: Gli accessori devono essere ordinati separatamente.

HSE-ACS1-H

Ausführung H3 = Gewinde G1/4" / Execution H3 = Thread G1/4" / Esecuzione H3 = filetto G1/4"

Bezeichnung Designation Articolo	EB	ET	h	b	L	KL	KT	Gewinde 1 Thread 1 Filetto 1	PG 25	Schneideinsatz Insert Inserito
HSE 1616L/R-SE2402-ET12-ACS1-H3	2	12	16	16	125	35	20	G 1/4"	●	SE 24-20...
HSE 1616L/R-SE2403-ET12-ACS1-H3	3	12	16	16	125	35	20	G 1/4"	●	SE 24-30...
HSE 1616L/R-SE2404-ET12-ACS1-H3	4	12	16	16	125	35	20	G 1/4"	●	SE 24-40...
HSE 2020L/R-SE2402-ET12-ACS1-H3	2	12	20	20	125	-	-	G 1/4"	●	SE 24-20...
HSE 2020L/R-SE2403-ET12-ACS1-H3	3	12	20	20	125	-	-	G 1/4"	●	SE 24-30...
HSE 2020L/R-SE2404-ET12-ACS1-H3	4	12	20	20	125	-	-	G 1/4"	●	SE 24-40...
HSE 2020L/R-SE2405-ET12-ACS1-H3	5	12	20	20	125	-	-	G 1/4"	●	SE 24-50...
HSE 2020L/R-SE2406-ET12-ACS1-H3	6	12	20	20	125	-	-	G 1/4"	●	SE 24-60...
HSE 2525L/R-SE2403-ET12-ACS1-H3	3	12	25	25	150	-	-	G 1/4"	●	SE 24-30...
HSE 2525L/R-SE2404-ET12-ACS1-H3	4	12	25	25	150	-	-	G 1/4"	●	SE 24-40...
HSE 2525L/R-SE2405-ET12-ACS1-H3	5	12	25	25	150	-	-	G 1/4"	●	SE 24-50...
HSE 2525L/R-SE2406-ET12-ACS1-H3	6	12	25	25	150	-	-	G 1/4"	●	SE 24-60...

Hinweis: Zubehör muss separat bestellt werden.

Remark: Accessories must be ordered separately.

Nota: Gli accessori devono essere ordinati separatamente.

Ersatzteile / Spare Parts / Ricambi

Trägerwerkzeug Holder Utensile	Schraube Screw Vite	Schlüssel Key Chiave
HSE 1616...HSE 2525... -SE24..ET..ACS1..	DIN912 M5X16-12.9	KP 1321

Zubehör / Accessories / Accessori

Bezeichnung Designation Articolo	A	B
KA 001 Kühlmittelanschluss – gerade Coolant supply – straight Raccordo – dritto	M8x1	Ø 6 mm
KA 002	1/8"	Ø 6 mm
KA 003	1/4"	Ø 10 mm
KA 004 Kühlmittelanschluss – winklig, fest Coolant supply – angled and fixed Raccordo – angolato	M8x1	Ø 6 mm
KA 005	1/8"	Ø 6 mm
KA 006 Schwenkverschraubung Swivelling screw-fitting Raccordo – orientabile	M8x1	Ø 6 mm
KA 007	1/8"	Ø 6 mm
KA 008	1/4"	Ø 10 mm

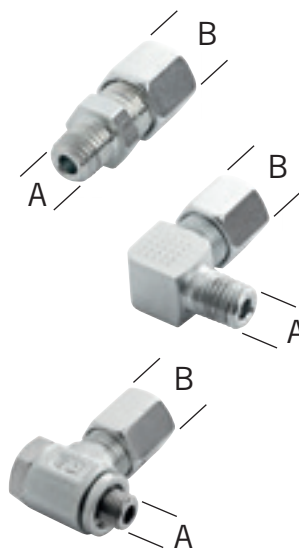

HSE-ACS1-H

Monoblockhalter mit Innenkühlung ACS1 von hinten (ET=21 mm)

Monoblock holder with through tool coolant access ACS1 from the back (ET=21 mm)

Utensile monoblocco con adduzione interna ACS1 posteriore (ET=21 mm)

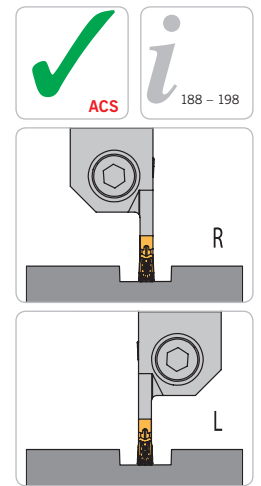
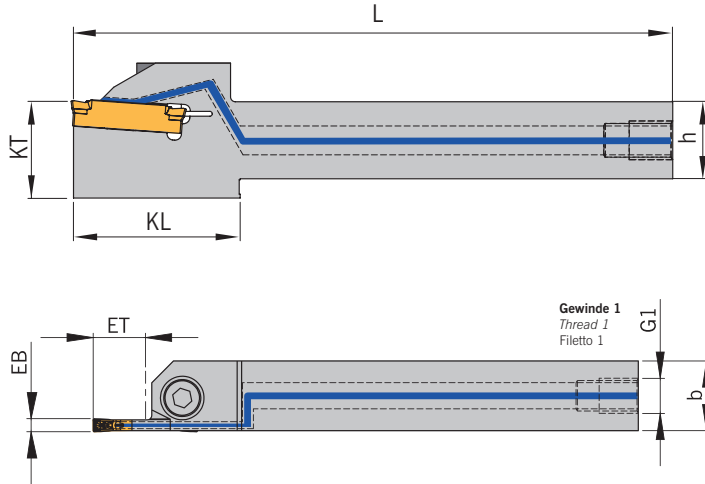

Rechte Ausführung abgebildet
Right-hand execution shown
Versione destra in figura

Trägerwerkzeuge / Holders / Utensili

Ausführung H1 = Gewinde M8x1 / Execution H1 = Thread M8x1 / Esecuzione H1 = filetto M8x1

Bezeichnung Designation Articolo	EB	ET	h	b	L	KL	KT	Gewinde 1 Thread 1 Filetto 1	PG 25	Schneideinsatz Insert Inserto
HSE 1616L/R-SE2402-ET21-ACS1-H1	2	21	16	16	125	44	20	M8x1	●	SE 24-20...
HSE 1616L/R-SE2403-ET21-ACS1-H1	3	21	16	16	125	44	20	M8x1	●	SE 24-30...
HSE 1616L/R-SE2404-ET21-ACS1-H1	4	21	16	16	125	44	20	M8x1	●	SE 24-40...
HSE 2020L/R-SE2402-ET21-ACS1-H1	2	21	20	20	125	-	-	M8x1	●	SE 24-20...
HSE 2020L/R-SE2403-ET21-ACS1-H1	3	21	20	20	125	-	-	M8x1	●	SE 24-30...
HSE 2020L/R-SE2404-ET21-ACS1-H1	4	21	20	20	125	-	-	M8x1	●	SE 24-40...
HSE 2020L/R-SE2405-ET21-ACS1-H1	5	21	20	20	125	-	-	M8x1	●	SE 24-50...
HSE 2020L/R-SE2406-ET21-ACS1-H1	6	21	20	20	125	-	-	M8x1	●	SE 24-60...
HSE 2525L/R-SE2403-ET21-ACS1-H1	3	21	25	25	150	-	-	M8x1	●	SE 24-30...
HSE 2525L/R-SE2404-ET21-ACS1-H1	4	21	25	25	150	-	-	M8x1	●	SE 24-40...
HSE 2525L/R-SE2405-ET21-ACS1-H1	5	21	25	25	150	-	-	M8x1	●	SE 24-50...
HSE 2525L/R-SE2406-ET21-ACS1-H1	6	21	25	25	150	-	-	M8x1	●	SE 24-60...

Hinweis: Zubehör muss separat bestellt werden.
Remark: Accessories must be ordered separately.
Nota: Gli accessori devono essere ordinati separatamente.

Ausführung H2 = Gewinde G1/8" / Execution H2 = Thread G1/8" / Esecuzione H2 = filetto G1/8"

Bezeichnung Designation Articolo	EB	ET	h	b	L	KL	KT	Gewinde 1 Thread 1 Filetto 1	PG 25	Schneideinsatz Insert Inserto
HSE 1616L/R-SE2402-ET21-ACS1-H2	2	21	16	16	125	44	20	G 1/8"	●	SE 24-20...
HSE 1616L/R-SE2403-ET21-ACS1-H2	3	21	16	16	125	44	20	G 1/8"	●	SE 24-30...
HSE 1616L/R-SE2404-ET21-ACS1-H2	4	21	16	16	125	44	20	G 1/8"	●	SE 24-40...
HSE 2020L/R-SE2402-ET21-ACS1-H2	2	21	20	20	125	-	-	G 1/8"	●	SE 24-20...
HSE 2020L/R-SE2403-ET21-ACS1-H2	3	21	20	20	125	-	-	G 1/8"	●	SE 24-30...
HSE 2020L/R-SE2404-ET21-ACS1-H2	4	21	20	20	125	-	-	G 1/8"	●	SE 24-40...
HSE 2020L/R-SE2405-ET21-ACS1-H2	5	21	20	20	125	-	-	G 1/8"	●	SE 24-50...
HSE 2020L/R-SE2406-ET21-ACS1-H2	6	21	20	20	125	-	-	G 1/8"	●	SE 24-60...
HSE 2525L/R-SE2403-ET21-ACS1-H2	3	21	25	25	150	-	-	G 1/8"	●	SE 24-30...
HSE 2525L/R-SE2404-ET21-ACS1-H2	4	21	25	25	150	-	-	G 1/8"	●	SE 24-40...
HSE 2525L/R-SE2405-ET21-ACS1-H2	5	21	25	25	150	-	-	G 1/8"	●	SE 24-50...
HSE 2525L/R-SE2406-ET21-ACS1-H2	6	21	25	25	150	-	-	G 1/8"	●	SE 24-60...

Hinweis: Zubehör muss separat bestellt werden.
Remark: Accessories must be ordered separately.
Nota: Gli accessori devono essere ordinati separatamente.

HSE-ACS1-H

Ausführung H3 = Gewinde G1/4" / Execution H3 = Thread G1/4" / Esecuzione H3 = filetto G1/4"

Bezeichnung Designation Articolo	EB	ET	h	b	L	KL	KT	Gewinde 1 Thread 1 Filetto 1	PG 25	Schneideinsatz Insert Inserito
HSE 1616L/R-SE2402-ET21-ACS1-H3	2	21	16	16	125	44	20	G 1/4"	●	SE 24-20...
HSE 1616L/R-SE2403-ET21-ACS1-H3	3	21	16	16	125	44	20	G 1/4"	●	SE 24-30...
HSE 1616L/R-SE2404-ET21-ACS1-H3	4	21	16	16	125	44	20	G 1/4"	●	SE 24-40...
HSE 2020L/R-SE2402-ET21-ACS1-H3	2	21	20	20	125	-	-	G 1/4"	●	SE 24-20...
HSE 2020L/R-SE2403-ET21-ACS1-H3	3	21	20	20	125	-	-	G 1/4"	●	SE 24-30...
HSE 2020L/R-SE2404-ET21-ACS1-H3	4	21	20	20	125	-	-	G 1/4"	●	SE 24-40...
HSE 2020L/R-SE2405-ET21-ACS1-H3	5	21	20	20	125	-	-	G 1/4"	●	SE 24-50...
HSE 2020L/R-SE2406-ET21-ACS1-H3	6	21	20	20	125	-	-	G 1/4"	●	SE 24-60...
HSE 2525L/R-SE2403-ET21-ACS1-H3	3	21	25	25	150	-	-	G 1/4"	●	SE 24-30...
HSE 2525L/R-SE2404-ET21-ACS1-H3	4	21	25	25	150	-	-	G 1/4"	●	SE 24-40...
HSE 2525L/R-SE2405-ET21-ACS1-H3	5	21	25	25	150	-	-	G 1/4"	●	SE 24-50...
HSE 2525L/R-SE2406-ET21-ACS1-H3	6	21	25	25	150	-	-	G 1/4"	●	SE 24-60...

Hinweis: Zubehör muss separat bestellt werden.

Remark: Accessories must be ordered separately.

Nota: Gli accessori devono essere ordinati separatamente.

ARNO® SpecialDesign

Diese Monoblockhalter bekommen Sie mit Ihren spezifischen Kühlan schlüssen. Ein Anfrageblatt hierzu finden Sie auf Seite 175 oder im Internet unter: www.arno.de/service/downloads

The coolant inlet can be supplied to your specification, please complete enquiry sheet on page 175 or download this from: www.arno.de/service/downloads

Questi corpi utensile sono fornibili con specifiche connessioni del refrigerante, Vedere modulo richiesta a Pag. 175 o download del modulo da: www.arno.de/service/downloads

Ersatzteile / Spare Parts / Ricambi

Trägerwerkzeug Holder Utensile	Schraube Screw Vite	Schlüssel Key Chiave
HSE 1616...HSE 2525... -SE24..ET..ACS1..	DIN912 M5X16-12.9	KP 1321

Zubehör / Accessories / Accessori

Bezeichnung Designation Articolo	A	B	
KA 001	Kühlmittelanschluss – gerade Coolant supply – straight Raccordo – dritto	M8x1	Ø 6 mm
KA 002		1/8"	Ø 6 mm
KA 003		1/4"	Ø 10 mm
KA 004	Kühlmittelanschluss – winklig, fest Coolant supply – angled and fixed Raccordo – angolato	M8x1	Ø 6 mm
KA 005		1/8"	Ø 6 mm
KA 006	Schwenkverschraubung Swivelling screw-fitting Raccordo – orientabile	M8x1	Ø 6 mm
KA 007		1/8"	Ø 6 mm
KA 008		1/4"	Ø 10 mm

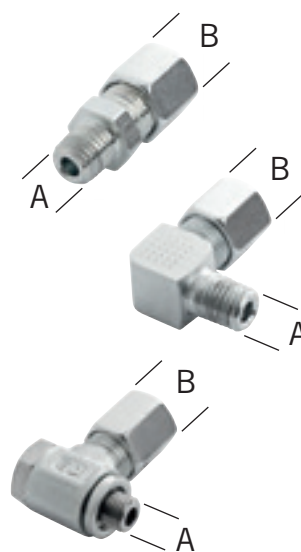

Monoblockhalter mit Innenkühlung ACS1 von hinten

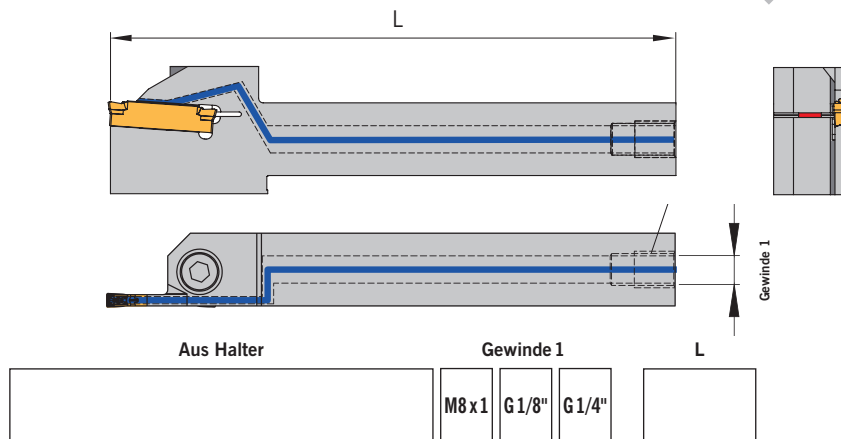

Diese Halter fertigen wir Ihnen zum Preis des Standardwerkzeuges.

2

Monoblockhalter mit Innenkühlung ACS1 von der Seite

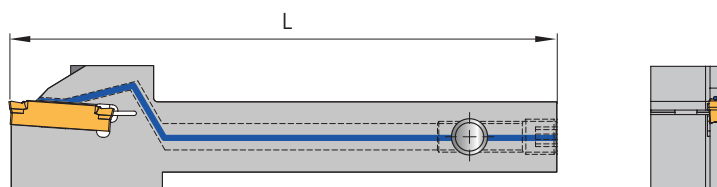

Ausführung S. – Das Gewinde 2 ist auf der gleichen Seite wie die Schneide

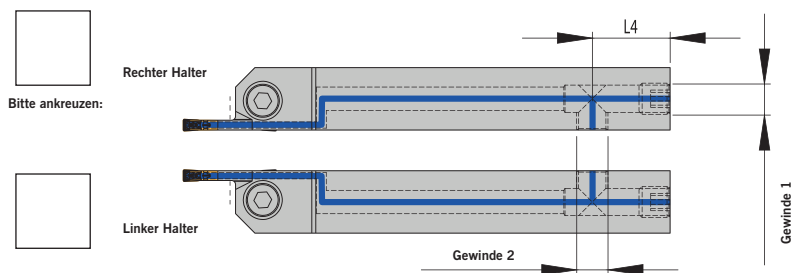

Ausführung SG. – Das Gewinde 2 ist gegenüber der Schneide

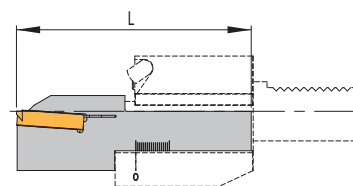
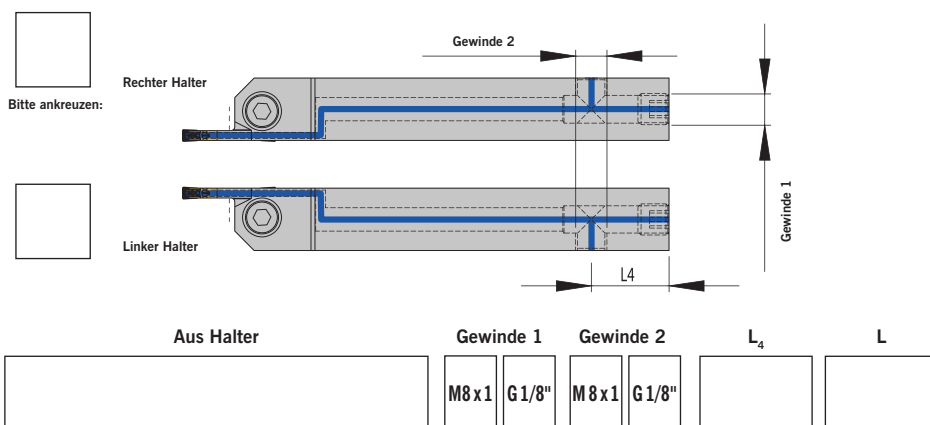

Hinweis bei Verwendung auf KMH-Werkzeugaufnahme (VDI) Form C

Beim Einsatz der Halter in VDI-Aufnahmen Form C bitte die Gesamtlänge (L) nach folgender Maximallänge festlegen:

ET12	L
HSE 1616L-SE2402-ET.... ACS1...	90
HSE 1616R-SE2402-ET.... ACS1...	
HSE 1616L-SE2403-ET.... ACS1...	
HSE 1616R-SE2403-ET.... ACS1...	
HSE 1616L-SE2404-ET.... ACS1...	
HSE 1616R-SE2404-ET.... ACS1...	
HSE 2020L-SE2402-ET.... ACS1...	94
HSE 2020R-SE2402-ET.... ACS1...	
HSE 2020L-SE2403-ET.... ACS1...	
HSE 2020R-SE2403-ET.... ACS1...	
HSE 2020L-SE2404-ET.... ACS1...	
HSE 2020R-SE2404-ET.... ACS1...	
HSE 2020L-SE2405-ET.... ACS1...	107
HSE 2020R-SE2405-ET.... ACS1...	
HSE 2020L-SE2406-ET.... ACS1...	
HSE 2020R-SE2406-ET.... ACS1...	
HSE 2525L-SE2403-ET.... ACS1...	
HSE 2525R-SE2403-ET.... ACS1...	
HSE 2525L-SE2404-ET.... ACS1...	109
HSE 2525R-SE2404-ET.... ACS1...	
HSE 2525L-SE2405-ET.... ACS1...	
HSE 2525R-SE2405-ET.... ACS1...	
HSE 2525L-SE2406-ET.... ACS1...	
HSE 2525R-SE2406-ET.... ACS1...	

ET21	L
HSE 1616L-SE2402-ET.... ACS1...	99
HSE 1616R-SE2402-ET.... ACS1...	
HSE 1616L-SE2403-ET.... ACS1...	
HSE 1616R-SE2403-ET.... ACS1...	
HSE 1616L-SE2404-ET.... ACS1...	
HSE 1616R-SE2404-ET.... ACS1...	
HSE 2020L-SE2402-ET.... ACS1...	103
HSE 2020R-SE2402-ET.... ACS1...	
HSE 2020L-SE2403-ET.... ACS1...	
HSE 2020R-SE2403-ET.... ACS1...	
HSE 2020L-SE2404-ET.... ACS1...	
HSE 2020R-SE2404-ET.... ACS1...	
HSE 2020L-SE2405-ET.... ACS1...	116
HSE 2020R-SE2405-ET.... ACS1...	
HSE 2020L-SE2406-ET.... ACS1...	
HSE 2020R-SE2406-ET.... ACS1...	
HSE 2525L-SE2403-ET.... ACS1...	
HSE 2525R-SE2403-ET.... ACS1...	
HSE 2525L-SE2404-ET.... ACS1...	116
HSE 2525R-SE2404-ET.... ACS1...	
HSE 2525L-SE2405-ET.... ACS1...	
HSE 2525R-SE2405-ET.... ACS1...	
HSE 2525L-SE2406-ET.... ACS1...	
HSE 2525R-SE2406-ET.... ACS1...	

Download dieses Formulars unter: www.arno.de/service/downloads

Monoblock holder with through tool coolant access from the back



2

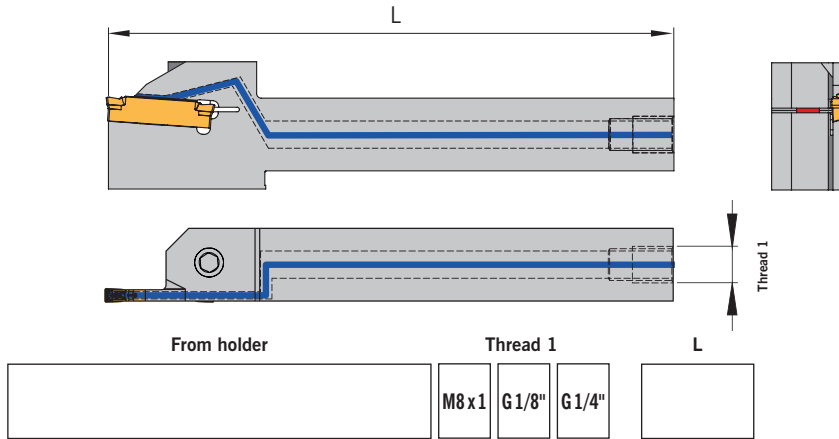

This tool we produce to the price of the standard tool.

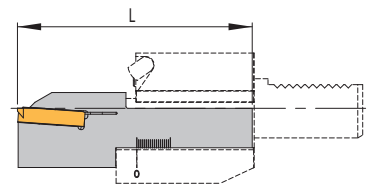

Monoblock holder with through tool coolant access from the side

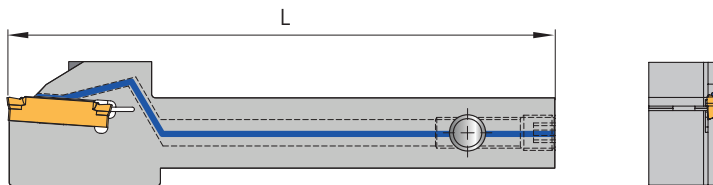

Remark by using the KMH holders (VDI) Form C

When using VDI holders Form C, please set overall length (L) by following maximum lengths:

Design S. – Thread 2 is on the same side as the cutting edge

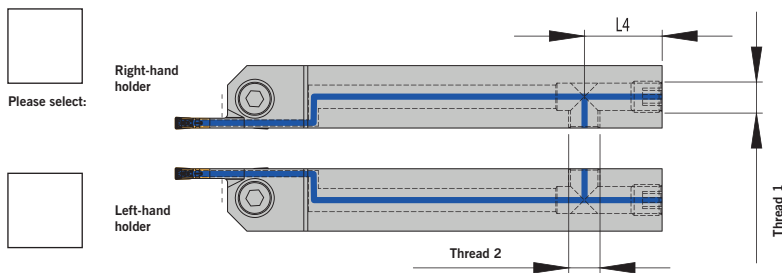

ET12	L
HSE 1616L-SE2402-ET.... ACS1...	90
HSE 1616R-SE2402-ET.... ACS1...	
HSE 1616L-SE2403-ET.... ACS1...	
HSE 1616R-SE2403-ET.... ACS1...	
HSE 1616L-SE2404-ET.... ACS1...	
HSE 1616R-SE2404-ET.... ACS1...	
HSE 2020L-SE2402-ET.... ACS1...	94
HSE 2020R-SE2402-ET.... ACS1...	
HSE 2020L-SE2403-ET.... ACS1...	
HSE 2020R-SE2403-ET.... ACS1...	
HSE 2020L-SE2404-ET.... ACS1...	
HSE 2020R-SE2404-ET.... ACS1...	
HSE 2020L-SE2405-ET.... ACS1...	107
HSE 2020R-SE2405-ET.... ACS1...	
HSE 2020L-SE2406-ET.... ACS1...	
HSE 2020R-SE2406-ET.... ACS1...	
HSE 2525L-SE2403-ET.... ACS1...	
HSE 2525R-SE2403-ET.... ACS1...	
HSE 2525L-SE2404-ET.... ACS1...	107
HSE 2525R-SE2404-ET.... ACS1...	
HSE 2525L-SE2405-ET.... ACS1...	
HSE 2525R-SE2405-ET.... ACS1...	
HSE 2525L-SE2406-ET.... ACS1...	
HSE 2525R-SE2406-ET.... ACS1...	

Design SG. – Thread 2 is on the opposite side of the cutting edge

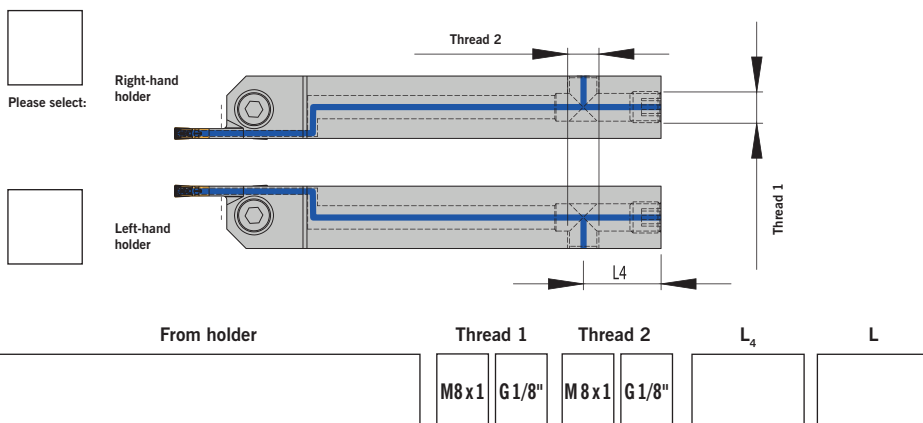

ET21	L
HSE 1616L-SE2402-ET.... ACS1...	99
HSE 1616R-SE2402-ET.... ACS1...	
HSE 1616L-SE2403-ET.... ACS1...	
HSE 1616R-SE2403-ET.... ACS1...	
HSE 1616L-SE2404-ET.... ACS1...	
HSE 1616R-SE2404-ET.... ACS1...	
HSE 2020L-SE2402-ET.... ACS1...	103
HSE 2020R-SE2402-ET.... ACS1...	
HSE 2020L-SE2403-ET.... ACS1...	
HSE 2020R-SE2403-ET.... ACS1...	
HSE 2020L-SE2404-ET.... ACS1...	
HSE 2020R-SE2404-ET.... ACS1...	
HSE 2020L-SE2405-ET.... ACS1...	116
HSE 2020R-SE2405-ET.... ACS1...	
HSE 2020L-SE2406-ET.... ACS1...	
HSE 2020R-SE2406-ET.... ACS1...	
HSE 2525L-SE2403-ET.... ACS1...	
HSE 2525R-SE2403-ET.... ACS1...	
HSE 2525L-SE2404-ET.... ACS1...	116
HSE 2525R-SE2404-ET.... ACS1...	
HSE 2525L-SE2405-ET.... ACS1...	
HSE 2525R-SE2405-ET.... ACS1...	
HSE 2525L-SE2406-ET.... ACS1...	
HSE 2525R-SE2406-ET.... ACS1...	

Download this form from: www.arno.de/service/downloads

Utensile monoblocco con adduzione interna ACS1 posteriore



Questi utensili vengono realizzati al prezzo dello standard.

2

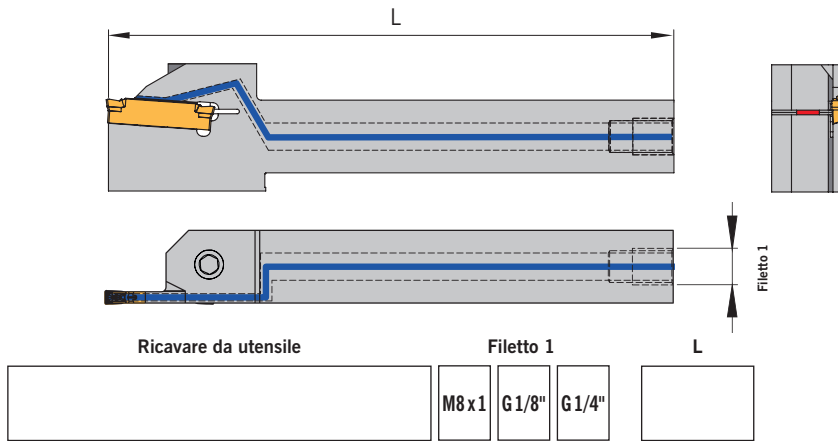

Utensile monoblocco con adduzione interna ACS1 laterale

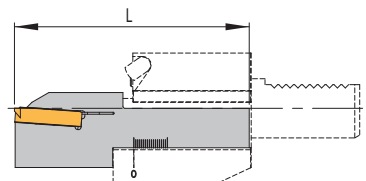

Nota sull'utilizzo adattatori KMH (VDI) Forma C

Con l'utilizzo di adattatori VDI forma C impostare la lunghezza totale (L) secondo la seguente tabella:

Versione S. – Filettatura 2 sul medesimo lato dell'inserto

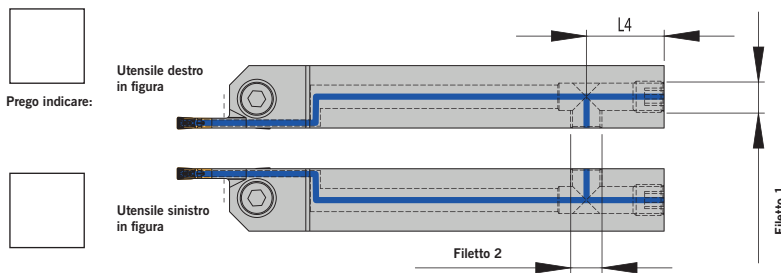

Versione SG. – Filettatura 2 sul lato opposto l'inserto

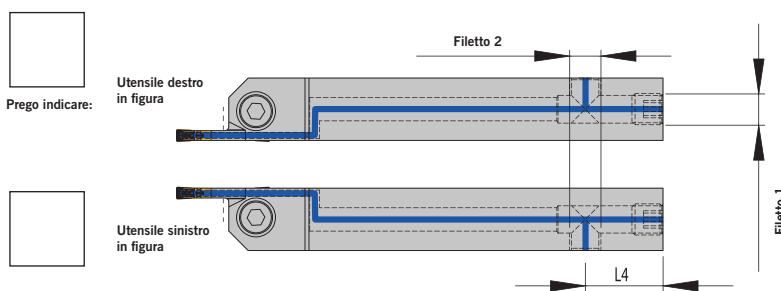

Ricavare da utensile	Filetto 1	Filetto 2	L ₄	L
	M8x1	G1/8"	M8x1	G1/8"

ET12	L
HSE 1616L-SE2402-ET.... ACS1...	90
HSE 1616R-SE2402-ET.... ACS1...	
HSE 1616L-SE2403-ET.... ACS1...	
HSE 1616R-SE2403-ET.... ACS1...	
HSE 1616L-SE2404-ET.... ACS1...	
HSE 1616R-SE2404-ET.... ACS1...	
HSE 2020L-SE2402-ET.... ACS1...	94
HSE 2020R-SE2402-ET.... ACS1...	
HSE 2020L-SE2403-ET.... ACS1...	
HSE 2020R-SE2403-ET.... ACS1...	
HSE 2020L-SE2404-ET.... ACS1...	
HSE 2020R-SE2404-ET.... ACS1...	
HSE 2020L-SE2405-ET.... ACS1...	107
HSE 2020R-SE2405-ET.... ACS1...	
HSE 2020L-SE2406-ET.... ACS1...	
HSE 2020R-SE2406-ET.... ACS1...	
HSE 2525L-SE2403-ET.... ACS1...	
HSE 2525R-SE2403-ET.... ACS1...	
HSE 2525L-SE2404-ET.... ACS1...	109
HSE 2525R-SE2404-ET.... ACS1...	
HSE 2525L-SE2405-ET.... ACS1...	
HSE 2525R-SE2405-ET.... ACS1...	
HSE 2525L-SE2406-ET.... ACS1...	
HSE 2525R-SE2406-ET.... ACS1...	

ET21	L
HSE 1616L-SE2402-ET.... ACS1...	99
HSE 1616R-SE2402-ET.... ACS1...	
HSE 1616L-SE2403-ET.... ACS1...	
HSE 1616R-SE2403-ET.... ACS1...	
HSE 1616L-SE2404-ET.... ACS1...	
HSE 1616R-SE2404-ET.... ACS1...	
HSE 2020L-SE2402-ET.... ACS1...	103
HSE 2020R-SE2402-ET.... ACS1...	
HSE 2020L-SE2403-ET.... ACS1...	
HSE 2020R-SE2403-ET.... ACS1...	
HSE 2020L-SE2404-ET.... ACS1...	
HSE 2020R-SE2404-ET.... ACS1...	
HSE 2020L-SE2405-ET.... ACS1...	116
HSE 2020R-SE2405-ET.... ACS1...	
HSE 2020L-SE2406-ET.... ACS1...	
HSE 2020R-SE2406-ET.... ACS1...	
HSE 2525L-SE2403-ET.... ACS1...	
HSE 2525R-SE2403-ET.... ACS1...	
HSE 2525L-SE2404-ET.... ACS1...	116
HSE 2525R-SE2404-ET.... ACS1...	
HSE 2525L-SE2405-ET.... ACS1...	
HSE 2525R-SE2405-ET.... ACS1...	
HSE 2525L-SE2406-ET.... ACS1...	
HSE 2525R-SE2406-ET.... ACS1...	

Download del formula da: www.arno.de/service/downloads

Monoblock holders with KMH holder (VDI)
Adattatore KMH (VDI) per utensili monoblocco

HSE-ACS1-UN auf KMH01 – Form B HSE-ACS1-UN with KMH01 – Form B HSE-ACS1-UN con adattatore KMH01 – Forma B

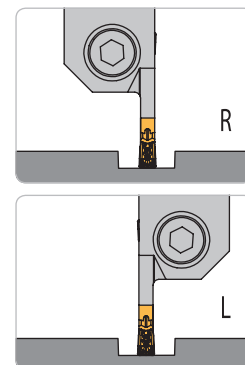

Linke Ausführung abgebildet
Left hand execution shown
Versione sinistra in figura

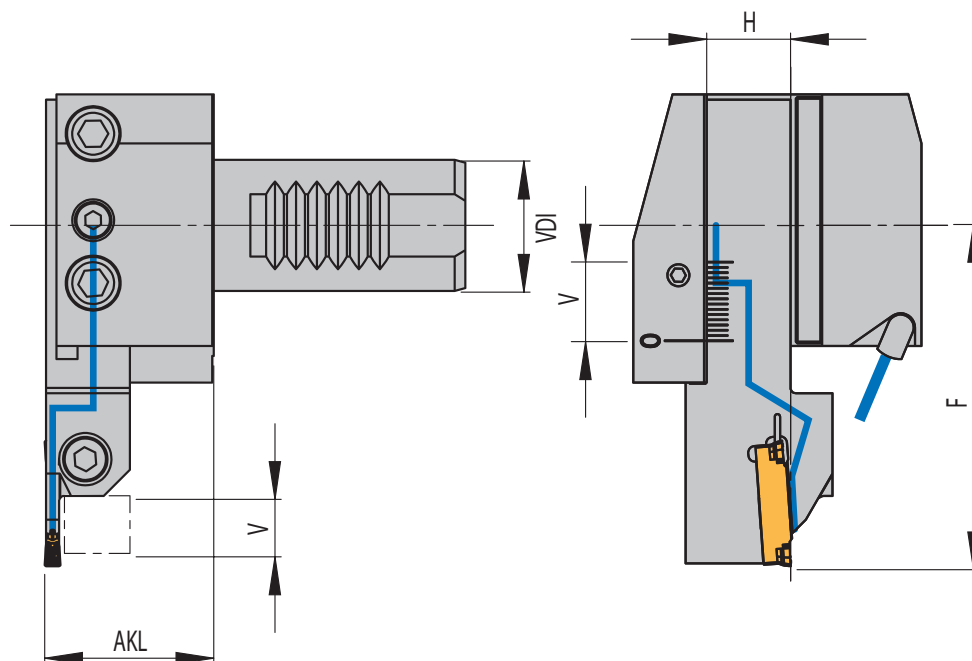

2

Handling: In Tabelle 1 den benötigten KMH-Werkzeughalter (VDI) und den Halter-Typ auswählen. Entsprechend dem Halter-Typ den benötigten Monoblockhalter und die Schneidplatte mit Tabelle 2 bestimmen.

HANDLING: Please select the KMH holder (VDI) and holder type from table 1. According to holder type please select suitable monoblock holder and insert from table 2.

GUIDA ALLA LETTURA: Scegliere l'adattatore KMH (VDI) e tipologia di forma dalla tabella 1. Dalla tabella 2 scegliere il relativo utensile ed inserto.

KMH-Werkzeugaufnahme / KMH holder / Adattatore KMH

Form B für HSE...ACS1-UN / Form B for HSE...ACS1-UN / Forma B per HSE...ACS1-UN

Form Form Forma	VDI	H _{Schaft / Shank / Stelo}	AKL	V*	KMH-Werkzeugaufnahme (VDI) KMH holder (VDI) Adattatore KMH (VDI)	PG 47	Monoblockhalter Monoblock holder Tipo utensile	
Tabelle 1 / Table 1 / Tabella 1	B1	25	16	32,3	15	KMH01-B1-25x16x30-IK	●	HSE 1616 L ...
		30	20	42,3	17	KMH01-B1-30x20x40-IK	●	HSE 2020 L ...
		40	25	47,3	22	KMH01-B1-40x25x44-IK	●	HSE 2525 L ...
	B2	25	16	32,3	15	KMH01-B2-25x16x30-IK	●	HSE 1616 R ...
		30	20	42,3	17	KMH01-B2-30x20x40-IK	●	HSE 2020 R ...
		40	25	47,3	22	KMH01-B2-40x25x44-IK	●	HSE 2525 R ...
	B3	25	16	32,3	15	KMH01-B3-25x16x30-IK	●	HSE 1616 R ...
		30	20	42,3	17	KMH01-B3-30x20x40-IK	●	HSE 2020 R ...
		40	25	47,3	22	KMH01-B3-40x25x44-IK	●	HSE 2525 R ...
	B4	25	16	32,3	15	KMH01-B4-25x16x30-IK	●	HSE 1616 L ...
		30	20	42,3	17	KMH01-B4-30x20x40-IK	●	HSE 2020 L ...
		40	25	47,3	22	KMH01-B4-40x25x44-IK	●	HSE 2525 L ...

* Der Halter kann um den Wert „V“ in der VDI-Aufnahme nach vorne geschoben werden. Die Kühlmittelversorgung ist innerhalb des Verstellwegs durch eine mechanische Begrenzung sichergestellt. Das „F“-Maß ändert sich entsprechend.
* The tool holder can be extended by dimension „V“ in the VDI holder. The coolant supply is guaranteed within the adjustment range by a mechanical limitation. Dimension „F“ changes accordingly.
* L'utensile può essere estratto dal portautensile del valore „V“ massimo. L'adduzione del refrigerante è garantita tramite un fermo. Dimensione „F“ cambia in relazione.

Ersatzteile wie Kühlmitteldüse und Schraube für Kühlmitteldüse finden Sie auf Seite 458 – 468
Spare parts like coolant jet and screw for coolant jet can be found on page 458 – 468
Ricambi come ugello refrigerante e vite per ugello refrigerante vedere pagina 458 – 468

Monoblock holders with KMH holder (VDI)
Adattatore KMH (VDI) per utensili monoblocco

HSE... -ACS1-UN.. für KMH-Werkzeugaufnahmen (VDI) / HSE... -ACS1-UN.. for KMH holder (VDI) / HSE...-ACS1-UN.. per adattatori KMH (VDI)





Monoblockhalter mit Innenkühlung ACS1 von unten (Nut) (ET = 12 mm) / Monoblock holder with coolant supply from the bottom (Notch) (ET = 12 mm) / Utensili monoblocco con refrigerazione interna ACS1 da sotto (Asola) (ET = 12 mm)

Monoblockhalter Monoblock holder Tipo utensile	D _{max}	EB	ET	Bezeichnung Designation Articolo	F	D _R	PG 25	H	Schneideinsatz Insert Inserto
HSE 1616 L ...	-	2	12	HSE 1616L-SE2402-ET12-ACS1-UN	65	-	●	16	SE 24-20....
	-	3	12	HSE 1616L-SE2403-ET12-ACS1-UN		-	●		SE 24-30....
	-	4	12	HSE 1616L-SE2404-ET12-ACS1-UN		-	●		SE 24-40....
HSE 1616 R ...	-	2	12	HSE 1616R-SE2402-ET12-ACS1-UN	65	-	●	16	SE 24-20....
	-	3	12	HSE 1616R-SE2403-ET12-ACS1-UN		-	●		SE 24-30....
	-	4	12	HSE 1616R-SE2404-ET12-ACS1-UN		-	●		SE 24-40....
HSE 2020 L ...	-	2	12	HSE 2020L-SE2402-ET12-ACS1-UN	59	-	●	20	SE 24-20....
	-	3	12	HSE 2020L-SE2403-ET12-ACS1-UN		-	●		SE 24-30....
	-	4	12	HSE 2020L-SE2404-ET12-ACS1-UN		-	●		SE 24-40....
	-	5	12	HSE 2020L-SE2405-ET12-ACS1-UN		-	●		SE 24-50....
HSE 2020 R ...	-	2	12	HSE 2020R-SE2402-ET12-ACS1-UN	59	-	●	20	SE 24-20....
	-	3	12	HSE 2020R-SE2403-ET12-ACS1-UN		-	●		SE 24-30....
	-	4	12	HSE 2020R-SE2404-ET12-ACS1-UN		-	●		SE 24-40....
	-	5	12	HSE 2020R-SE2405-ET12-ACS1-UN		-	●		SE 24-50....
HSE 2525 L ...	-	3	12	HSE 2525L-SE2403-ET12-ACS1-UN	64	-	●	25	SE 24-30....
	-	4	12	HSE 2525L-SE2404-ET12-ACS1-UN		-	●		SE 24-40....
	-	5	12	HSE 2525L-SE2405-ET12-ACS1-UN		-	●		SE 24-50....
	-	6	12	HSE 2525L-SE2406-ET12-ACS1-UN		-	●		SE 24-60....
HSE 2525 R ...	-	3	12	HSE 2525R-SE2403-ET12-ACS1-UN	64	-	●	25	SE 24-30....
	-	4	12	HSE 2525R-SE2404-ET12-ACS1-UN		-	●		SE 24-40....
	-	5	12	HSE 2525R-SE2405-ET12-ACS1-UN		-	●		SE 24-50....
	-	6	12	HSE 2525R-SE2406-ET12-ACS1-UN		-	●		SE 24-60....

Tabelle 2 / Table 2 / Tabella 2

2

Einbaumöglichkeiten / Assembly options / Combinazioni di montaggio

Halter KMH01-B ... mit linkem Monoblockhalter Holder KMH01-B ... with left-hand monoblock holder Adattatore KMH01-B ... con utensile monoblocco sinistro		Halter KMH01-B ... mit rechtem Monoblockhalter Holder KMH01-B ... with right-hand monoblock holder Adattatore KMH01-B ... con utensile monoblocco destro	
KMH01-B1 ...	KMH01-B4 ...	KMH01-B2 ...	KMH01-B3 ...
			
Einbaulage normal Normal assembly Montaggio normale	Einbaulage Überkopf Upside down assembly Montaggio invertito	Einbaulage normal Normal assembly Montaggio normale	Einbaulage Überkopf Upside down assembly Montaggio invertito

Monoblock holders with KMH holder (VDI)
Adattatore KMH (VDI) per utensili monoblocco

HSE...-ACS1-UN.. für KMH-Werkzeugaufnahmen (VDI) / HSE...-ACS1-UN.. for KMH holder (VDI) / HSE...-ACS1-UN.. per adattatori KMH (VDI)

Monoblockhalter mit Innenkühlung ACS1 von unten (Nut) (ET = 21 mm) / Monoblock holder with coolant supply from the bottom (Notch) (ET = 21 mm) / Utensili monoblocco con refrigerazione interna ACS1 da sotto (Asola) (ET = 21 mm)

Monoblockhalter Monoblock holder Tipo utensile	D _{max}	EB	ET	Bezeichnung Designation Articolo	F	D _R	PG 25	H	Schneideinsatz Insert Inserto
HSE 1616 L ...	-	2	21	HSE 1616L-SE2402-ET21-ACS1-UN	74	-	●	16	SE 24-20....
	-	3	21	HSE 1616L-SE2403-ET21-ACS1-UN		-	●		SE 24-30....
	-	4	21	HSE 1616L-SE2404-ET21-ACS1-UN		-	●		SE 24-40....
HSE 1616 R ...	-	2	21	HSE 1616R-SE2402-ET21-ACS1-UN	74	-	●	16	SE 24-20....
	-	3	21	HSE 1616R-SE2403-ET21-ACS1-UN		-	●		SE 24-30....
	-	4	21	HSE 1616R-SE2404-ET21-ACS1-UN		-	●		SE 24-40....
HSE 2020 L ...	-	2	21	HSE 2020L-SE2402-ET21-ACS1-UN	68	-	●	20	SE 24-20....
	-	3	21	HSE 2020L-SE2403-ET21-ACS1-UN		-	●		SE 24-30....
	-	4	21	HSE 2020L-SE2404-ET21-ACS1-UN		-	●		SE 24-40....
	-	5	21	HSE 2020L-SE2405-ET21-ACS1-UN		-	●		SE 24-50....
HSE 2020 R ...	-	2	21	HSE 2020R-SE2402-ET21-ACS1-UN	68	-	●	20	SE 24-20....
	-	3	21	HSE 2020R-SE2403-ET21-ACS1-UN		-	●		SE 24-30....
	-	4	21	HSE 2020R-SE2404-ET21-ACS1-UN		-	●		SE 24-40....
	-	5	21	HSE 2020R-SE2405-ET21-ACS1-UN		-	●		SE 24-50....
HSE 2525 L ...	-	3	21	HSE 2525L-SE2403-ET21-ACS1-UN	73	-	●	25	SE 24-30....
	-	4	21	HSE 2525L-SE2404-ET21-ACS1-UN		-	●		SE 24-40....
	-	5	21	HSE 2525L-SE2405-ET21-ACS1-UN		-	●		SE 24-50....
	-	6	21	HSE 2525L-SE2406-ET21-ACS1-UN		-	●		SE 24-60....
HSE 2525 R ...	-	3	21	HSE 2525R-SE2403-ET21-ACS1-UN	73	-	●	25	SE 24-30....
	-	4	21	HSE 2525R-SE2404-ET21-ACS1-UN		-	●		SE 24-40....
	-	5	21	HSE 2525R-SE2405-ET21-ACS1-UN		-	●		SE 24-50....
	-	6	21	HSE 2525R-SE2406-ET21-ACS1-UN		-	●		SE 24-60....

Tabelle 2 / Table 2 / Tabella 2

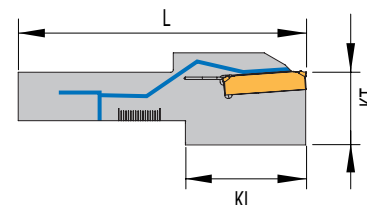

Ersatzteile / Spare Parts / Ricambi

Trägerwerkzeug Holder Utensile	Schraube Screw Vite	Schlüssel Key Chiave
HSE 1616.....HSE 2525.....-SE24...ET...ACS1...	DIN912 M5x16-12.9	KP 1321

Monoblock holders with KMH holder (VDI)
Adattatore KMH (VDI) per utensili monoblocco

HSE-ACS1-UN auf KMH01 – Form C HSE-ACS1-UN with KMH01 – Form C HSE-ACS1-UN con adattatore KMH01 – Forma C

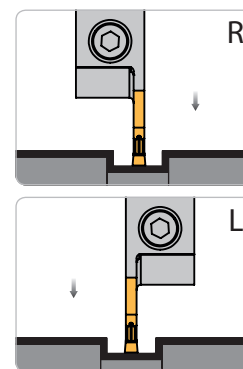
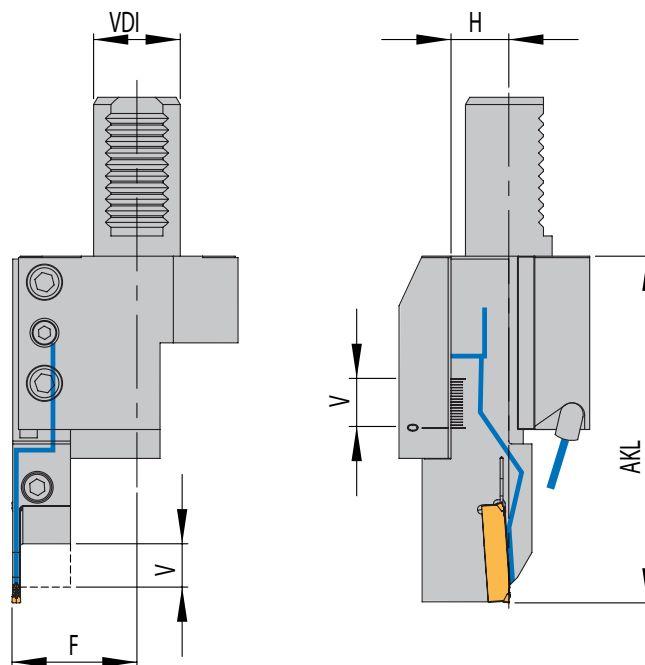

Linke Ausführung abgebildet
Left-hand execution shown
Versione sinistra in figura

2

NEU/NEW/NUOVO

Handling: In Tabelle 1 den benötigten KMH-Werkzeughalter (VDI) und den Halter-Typ auswählen. Entsprechend dem Halter-Typ den benötigten Monoblockhalter und die Schneidplatte mit Tabelle 2 bestimmen.
HANDLING: Please select the KMH holder (VDI) and holder type from table 1. According to holder type please select suitable monoblock holder and insert from table 2.
GUIDA ALLA LETTURA: Scegliere l'adattatore KMH (VDI) e tipologia di forma dalla tabella 1. Dalla tabella 2 scegliere il relativo utensile ed inserto.

KMH-Werkzeugaufnahme / KMH holder / Adattatore KMH

Form C für HSE...ACS1-UN / Form C for HSE...ACS1-UN / Forma C per HSE...ACS1-UN

Form Form Forma	VDI	H _{Schaft / Shank / Stelo}	AKL	V*	KMH-Werkzeugaufnahme (VDI) KMH holder (VDI) Adattatore KMH (VDI)	PG 47	Monoblockhalter Monoblock holder Tipo utensile
C1	25	16	35,3	15	KMH01-C1-25x16x55-IK	●	HSE 1616 R ...
	30	20	37,3	17	KMH01-C1-30x20x70-IK	●	HSE 2020 R ...
	40	25	46,3	22	KMH01-C1-40x25x85-IK	●	HSE 2525 R ...
C2	25	16	35,3	15	KMH01-C2-25x16x55-IK	●	HSE 1616 L ...
	30	20	37,3	17	KMH01-C2-30x20x70-IK	●	HSE 2020 L ...
	40	25	46,3	22	KMH01-C2-40x25x85-IK	●	HSE 2525 L ...
C3	25	16	35,3	15	KMH01-C3-25x16x55-IK	●	HSE 1616 L ...
	30	20	37,3	17	KMH01-C3-30x20x70-IK	●	HSE 2020 L ...
	40	25	46,3	22	KMH01-C3-40x25x85-IK	●	HSE 2525 L ...
C4	25	16	35,3	15	KMH01-C4-25x16x55-IK	●	HSE 1616 R ...
	25	20	39,3	17	KMH01-C4-25x20x70-IK	●	HSE 2020 R ...
	30	20	37,3	17	KMH01-C4-30x20x70-IK	●	HSE 2020 R ...
	40	25	46,3	22	KMH01-C4-40x25x85-IK	●	HSE 2525 R ...

* Der Halter kann um den Wert „V“ in der VDI-Aufnahme nach vorne geschoben werden. Die Kühlmittelversorgung ist innerhalb des Verstellwegs durch eine mechanische Begrenzung sichergestellt. Das „AKL“-Maß ändert sich entsprechend.

* The tool holder can be extended by dimension „V“ in the VDI holder. The coolant supply is guaranteed within the adjustment range by a mechanical limitation. Dimension „AKL“ changes accordingly.

* L'utensile può essere estratto dal portautensile del valore „V“ massimo. L'adduzione del refrigerante è garantita tramite un fermo. Dimensione "AKL" cambia in relazione.

Ersatzteile wie Kühlmitteldüse und Schraube für Kühlmitteldüse finden Sie auf Seite 470 – 477

Spare parts like coolant jet and screw for coolant jet can be found on page 470 – 477

Ricambi come ugello refrigerante e vite per ugello refrigerante vedere pagina 470 – 477

Monoblock holders with KMH holder (VDI)
 Adattatore KMH (VDI) per utensili monoblocco

HSE... -ACS1-UN.. für KMH-Werkzeugaufnahmen (VDI) / HSE... -ACS1-UN.. for KMH holder (VDI) / HSE...-ACS1-UN..per adattatori KMH (VDI)





Monoblockhalter mit Innenkühlung ACS1 von unten (Nutm) (ET = 12 mm) / Monoblock holder with coolant supply from the bottom (Notch) (ET = 12 mm) / Utensili monoblocco con refrigerazione interna ACS1 da sotto (Asola) (ET = 12 mm)

Monoblockhalter Monoblock holder Tipo utensile	D _{max}	EB	ET	Bezeichnung Designation Articolo	F	D _R	PG 25	H	Schneideinsatz Insert Inserto
HSE 1616 L ...	-	2	12	HSE 1616L-SE2402-ET12-ACS1-UN	90	-	●	16	SE 24-20....
	-	3	12	HSE 1616L-SE2403-ET12-ACS1-UN		-	●		SE 24-30....
	-	4	12	HSE 1616L-SE2404-ET12-ACS1-UN		-	●		SE 24-40....
HSE 1616 R ...	-	2	12	HSE 1616R-SE2402-ET12-ACS1-UN	90	-	●	16	SE 24-20....
	-	3	12	HSE 1616R-SE2403-ET12-ACS1-UN		-	●		SE 24-30....
	-	4	12	HSE 1616R-SE2404-ET12-ACS1-UN		-	●		SE 24-40....
HSE 2020 L ...	-	2	12	HSE 2020L-SE2402-ET12-ACS1-UN	94	-	●	20	SE 24-20....
	-	3	12	HSE 2020L-SE2403-ET12-ACS1-UN		-	●		SE 24-30....
	-	4	12	HSE 2020L-SE2404-ET12-ACS1-UN		-	●		SE 24-40....
	-	5	12	HSE 2020L-SE2405-ET12-ACS1-UN		-	●		SE 24-50....
HSE 2020 R ...	-	2	12	HSE 2020R-SE2402-ET12-ACS1-UN	94	-	●	20	SE 24-20....
	-	3	12	HSE 2020R-SE2403-ET12-ACS1-UN		-	●		SE 24-30....
	-	4	12	HSE 2020R-SE2404-ET12-ACS1-UN		-	●		SE 24-40....
	-	5	12	HSE 2020R-SE2405-ET12-ACS1-UN		-	●		SE 24-50....
HSE 2525 L ...	-	3	12	HSE 2525L-SE2403-ET12-ACS1-UN	107	-	●	25	SE 24-30....
	-	4	12	HSE 2525L-SE2404-ET12-ACS1-UN		-	●		SE 24-40....
	-	5	12	HSE 2525L-SE2405-ET12-ACS1-UN		-	●		SE 24-50....
	-	6	12	HSE 2525L-SE2406-ET12-ACS1-UN		-	●		SE 24-60....
HSE 2525 R ...	-	3	12	HSE 2525R-SE2403-ET12-ACS1-UN	107	-	●	25	SE 24-30....
	-	4	12	HSE 2525R-SE2404-ET12-ACS1-UN		-	●		SE 24-40....
	-	5	12	HSE 2525R-SE2405-ET12-ACS1-UN		-	●		SE 24-50....
	-	6	12	HSE 2525R-SE2406-ET12-ACS1-UN		-	●		SE 24-60....

2

Tabelle 2 / Table 2 / Tabella 2

Einbaumöglichkeiten / Assembly options / Combinazioni di montaggio

Halter KMH01-C ... mit linkem Monoblockhalter Holder KMH01-C ... with left-hand monoblock holder Adattatore KMH01-C ... con utensile monoblocco sinistro		Halter KMH01-C ... mit rechtem Monoblockhalter Holder KMH01-C ... with right-hand monoblock holder Adattatore KMH01-C ... con utensile monoblocco destro	
KMH01-C2 ...	KMH01-C3 ...	KMH01-C1 ...	KMH01-C4 ...
			
Einbaulage normal Normal assembly Montaggio normale	Einbaulage Überkopf Upside down assembly Montaggio invertito	Einbaulage normal Normal assembly Montaggio normale	Einbaulage Überkopf Upside down assembly Montaggio invertito

Monoblock holders with KMH holder (VDI)
Adattatore KMH (VDI) per utensili monoblocco

HSE...-ACS1-UN.. für KMH-Werkzeugaufnahmen (VDI) / HSE...-ACS1-UN.. for KMH holder (VDI) / HSE...-ACS1-UN.. per adattatori KMH (VDI)

Monoblockhalter mit Innenkühlung ACS1 von unten (Nut) (ET = 21 mm) / Monoblock holder with coolant supply from the bottom (Notch) (ET = 21 mm) / Utensili monoblocco con refrigerazione interna ACS1 da sotto (Asola) (ET = 21 mm)

Monoblockhalter	D _{max}	EB	ET	Bezeichnung	AKL	D _R	PG 25/ Preis in €	H	Schneideinsatz
HSE 1616 L ...	-	2	21	HSE 1616L-SE2402-ET21-ACS1-UN	99	-	●	16	SE 24-20....
	-	3	21	HSE 1616L-SE2403-ET21-ACS1-UN		-	●		SE 24-30....
	-	4	21	HSE 1616L-SE2404-ET21-ACS1-UN		-	●		SE 24-40....
HSE 1616 R ...	-	2	21	HSE 1616R-SE2402-ET21-ACS1-UN	99	-	●	16	SE 24-20....
	-	3	21	HSE 1616R-SE2403-ET21-ACS1-UN		-	●		SE 24-30....
	-	4	21	HSE 1616R-SE2404-ET21-ACS1-UN		-	●		SE 24-40....
HSE 2020 L ...	-	2	21	HSE 2020L-SE2402-ET21-ACS1-UN	103	-	●	20	SE 24-20....
	-	3	21	HSE 2020L-SE2403-ET21-ACS1-UN		-	●		SE 24-30....
	-	4	21	HSE 2020L-SE2404-ET21-ACS1-UN		-	●		SE 24-40....
	-	5	21	HSE 2020L-SE2405-ET21-ACS1-UN		-	●		SE 24-50....
HSE 2020 R ...	-	2	21	HSE 2020R-SE2402-ET21-ACS1-UN	103	-	●	20	SE 24-20....
	-	3	21	HSE 2020R-SE2403-ET21-ACS1-UN		-	●		SE 24-30....
	-	4	21	HSE 2020R-SE2404-ET21-ACS1-UN		-	●		SE 24-40....
	-	5	21	HSE 2020R-SE2405-ET21-ACS1-UN		-	●		SE 24-50....
HSE 2525 L ...	-	3	21	HSE 2525L-SE2403-ET21-ACS1-UN	116	-	●	25	SE 24-30....
	-	4	21	HSE 2525L-SE2404-ET21-ACS1-UN		-	●		SE 24-40....
	-	5	21	HSE 2525L-SE2405-ET21-ACS1-UN		-	●		SE 24-50....
	-	6	21	HSE 2525L-SE2406-ET21-ACS1-UN		-	●		SE 24-60....
HSE 2525 R ...	-	3	21	HSE 2525R-SE2403-ET21-ACS1-UN	116	-	●	25	SE 24-30....
	-	4	21	HSE 2525R-SE2404-ET21-ACS1-UN		-	●		SE 24-40....
	-	5	21	HSE 2525R-SE2405-ET21-ACS1-UN		-	●		SE 24-50....
	-	6	21	HSE 2525R-SE2406-ET21-ACS1-UN		-	●		SE 24-60....

Tabelle 2 / Table 2 / Tabella 2

2

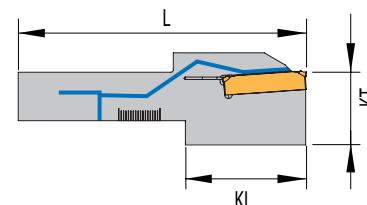

Ersatzteile / Spare Parts / Ricambi

Trägerwerkzeug Holder Utensile	Schraube Screw Vite	Schlüssel Key Chiave
HSE 1616.....HSE 2525.....-SE24...ET...ACS1...	DIN912 M5x16-12.9	KP 1321

**M2**

Erste Wahl für das Stechen und Längsdrehen

- **Hauptanwendung für Stahl und rostfreie Werkstoffe**
- **Stabile Schneidkanten für max. Vorschübe und Spantiefen**

M2

First choice for grooving and turning

- *Main application area is steel and stainless steel*
- *Strong cutting edge for maximum feed rate and cutting depth*

M2

Prima scelta per la scanalatura e tornitura longitudinale

- Principale applicazione su acciaio e acciai inossidabili
- Geometria robusta per massima velocità di avanzamento e profondità di taglio

**ALU**

Geometrie mit scharfer Schneide

- **Erste Wahl für Aluminium und NE-Metalle**
- **Umseitig geschliffener Schneideinsatz**
- **Hochpositive Geometrie**
- **Polierte Spanflächen**

ALU

Geometry with a sharp edge

- *First choice for aluminium and non-ferrous materials*
- *Periphery ground insert*
- *High positive design*
- *Polished chip breakers*

ALU

Geometria super positiva rettificata

- Prima scelta per Alluminio e materiali non ferrosi
- Inserto rettificato
- Spoglia di taglio molto positiva
- Vano truciolo lappato

**T1**

Sehr gute Spankontrolle und Einschnürung

- **Für Stahl und Rostfreibearbeitung**
- **Universell einsetzbar – auch bei dünnwandigen Bauteilen**

T1

Very good swarf control and formation

- *For steel and stainless steel*
- *Universal geometry machining, for thin-walled components*

T1

La geometria dall'ottimo controllo truciolo

- Per acciaio e materiali inossidabili
- Utilizzo universale, anche per pezzi sottili

Beschichtet / Coated / Rivestito

AM5040

PVD-beschichtete Hartmetallsorte

Eine zähe, universell einsetzbare Sorte für niedrige und mittlere Schnittgeschwindigkeiten. Hauptanwendungsbereich für rostfreie Stähle sowie für die Stahlbearbeitung. Gute Prozesssicherheit sowie beständig gegen Schneidkantenausbrüche.

PVD coated carbide

A tough but universal grade for low to medium cutting speeds. The main application area being stainless steel and steel.

Metallo duro rivestito PVD

Qualità universale per velocità medio basse. Campo di applicazione principale acciai inossidabili, superleghe, acciai legati. Notevole robustezza e resistenza alla scheggiatura.

AP2240

CVD-beschichtete Hartmetallsorte

Die AP2240 überzeugt mit großer Zähigkeit und hoher Wärmebeständigkeit und erreicht dadurch außerordentliche Standzeiten. Durch die stabilen Schneidkanten wird die Prozesssicherheit deutlich höher. Hauptanwendung dieser Sorte liegt in der Stahl- und Gussbearbeitung. In der Nebenanwendung ist sie auch für rostfreie Stähle zu empfehlen.

CVD coated carbide grade

The AP2240 provides more toughness and heat resistance and thereby even more tool life. The strong cutting edge improves the process reliability. Main application area is steel and cast iron machining. Can also be used for stainless steel machining.

Grado rivestito CVD

La qualità AP2240 offre maggiore tenacità e resistenza alle temperature incrementando la vita inserto. Il robusto tagliente incrementa l'affidabilità di lavorazione. Campo principale di impiego su acciaio e ghise acciaiose. Idoneo anche per alcuni acciai inox.

AP5020

PVD-beschichtete Hartmetallsorte

Eine sehr universell einsetzbare Sorte für niedrige und mittlere Schnittgeschwindigkeiten. Hauptanwendungsbereich für Stahl. Als Nebenanwendung geeignet für die Bearbeitung rostfreier Stähle und für das Ein- und Abstechen hochwärmfester Werkstoffe und NE-Metalle.

PVD coated carbide

A universal grade for low to medium cutting speed. Main application areas are steel and stainless steel, but also suitable for part-off and grooving of high temperature alloys and non-ferrous materials.

Metallo duro rivestito PVD

Qualità universale per velocità di taglio medie. Adatto principalmente per acciaio e secondariamente per acciaio inossidabile. Utilizzo secondario anche per metalli non ferrosi e refrattari.

AP5030

PVD-beschichtete Hartmetallsorte

Eine universell einsetzbare Sorte im Bereich P30-P35 für die Einstech- und Abstechbearbeitungen. Hauptanwendungsbereich für die Stahlbearbeitung, Nebenanwendung für rostfreie Stähle.

PVD coated carbide

A universal grade mainly for steel applications. The slightly tougher substrate (ISO P30-P35) makes it suitable also for stainless steel.

Metallo duro rivestito PVD

Qualità molto versatile su campo ISO P30-P35 per lavorazioni in sicurezza. Ottima per la lavorazione di acciai in condizioni non perfette di lavoro. Secondaria scelta per acciai inossidabili.

Unbeschichtet / Uncoated / Non rivestito

AN1015

Unbeschichtete Hartmetallsorte zum Schlichten und Schruppen von Aluminiumlegierungen und bei NE-Metallen in Verbindung mit geschliffenen Schneidkanten. Zur Reduzierung der Aufbauschneidenbildung ist die Spanfläche hochglanzpoliert.

Uncoated carbide grade which in connection with a ground cutting edge is for finishing and roughing of aluminium alloys and non-ferrous materials. In order to reduce build up edge problems the insert is also highly polished.

Grado di metallo duro micrograna per tutte le lavorazioni di materiali non ferrosi e Alluminio. Tagliente rettificato super positivo e spoglia lappata per ridurre tagliente di riporto.

SE24

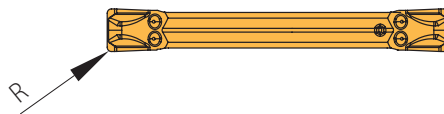
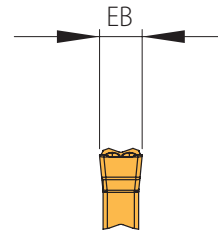
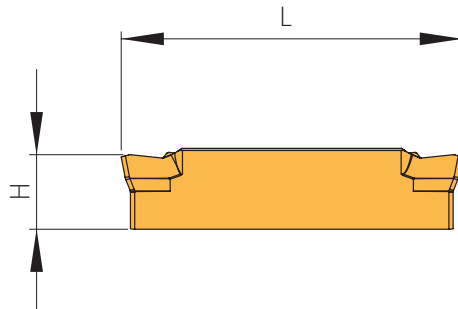

2

Gesinterte Ausführung / Sintered Execution / Esecuzione Sinterizzato

						PG 26			
						beschichtet coated rivestito			
Bezeichnung Designation Articolo	EB ± 0,04	H	L	R	χ	AM5040	AP2240	AP5020	AP5030
SE24-2002N-M2	2	5,5	24	0,2	0°	●		●	
SE24-2002N-T1	2	5,5	24	0,2	0°		●	●	
SE24-3002N-M2	3	5,5	24	0,2	0°	●		●	
SE24-3003N-M2	3	5,5	24	0,3	0°	●		●	
SE24-3003N-T1	3	5,5	24	0,3	0°		●	●	●
SE24-4004N-M2	4	5,5	24	0,4	0°	●		●	
SE24-4004N-T1	4	5,5	24	0,4	0°			●	
SE24-5004N-M2	5	7,5	24	0,4	0°	●		●	
SE24-5005N-T1	5	7,5	24	0,5	0°			●	
SE24-6008N-M2	6	7,5	24	0,8	0°	●		●	

P	○	●	●	●
M	●	○	○	○
K		●		
N			○	
S			○	○
H				

● **Hauptanwendung**
Main application
Applicazione principale

○ **Nebenanwendung**
Secondary application
Applicazione secondaria

SE24

Präzisionsgeschliffene Ausführung / Precision ground execution / Esecuzione rettifica di precisione

							PG 26
							unbeschichtet uncoated non rivestito
Bezeichnung Designation Articolo	EB ± 0,02	H	L	R	χ	AN1015	
SE24-2002N-ALU	2	5,5	24	0,2	0°	●	
SE24-3003N-ALU	3	5,5	24	0,3	0°	●	

P	
M	
K	○
N	●
S	○
H	

- **Hauptanwendung**
Main application
Applicazione principale
- **Nebenanwendung**
Secondary application
Applicazione secondaria



Spare parts and accessories
Ricambi e accessori

Artikel / Item / Articolo	PG 11
Schraube / Screw / Vite	
DIN912 M5X16-12.9	●
AS 0022	●
AS 0084	●
Schlüssel / Key / Chiave	
KA 006	●
KA 007	●
KA 008	●
Kühlmittelschluss – gerade / Coolant supply – straight / Raccordo – dritto	
KP 1321	●
T5215-IP	●
KP 3111	●
Kühlmittelschluss – winklig, fest / Coolant supply – angled and fixed / Raccordo – angolato	
KA 001	●
KA 002	●
KA 003	●
Schwenkverschraubung / Swivelling screw-fitting / Raccordo – orientabile	
KA 004	●
KA 005	●

2

Maximale Vorschübe und Spantiefen

Max. feed rate and depth of cut

Avanzamenti e profondità di taglio massimi

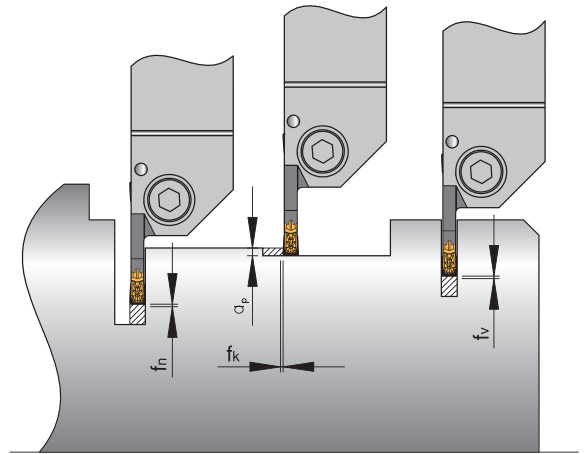

- | | | |
|--|--|---|
| f_v (mm/U) = Vorschub beim Einstechen | f_v (mm / U) = Feed rate into solid | f_v (mm / U) = Avanzamento nel pieno |
| f_n (mm/U) = Vorschub beim Nachstechen | f_n (mm / U) = Feed rate for re-grooving | f_n (mm / U) = Avanzamento di ripresa |
| f_k (mm/U) = Vorschub beim Kopieren | f_k (mm / U) = Feed rate for copying | f_k (mm / U) = Avanzamento per copiatura |
| a_p (mm) = Schnitttiefe beim Kopieren | a_p (mm) = Depth of cut for copying | a_p (mm) = Profondità di taglio per copiatura |

Geometrie M2 / Geometry M2 / Geometria M2

	Schneideinsatz / Insert / Insetto				
	SE24-20....	SE24-30....	SE24-40....	SE24-50....	SE24-60....
f_v mm/U	0,04 – 0,08 – 0,12	0,08 – 0,13 – 0,18	0,12 – 0,18 – 0,24	0,12 – 0,21 – 0,30	0,15 – 0,25 – 0,35
f_n mm/U	0,04 – 0,12 – 0,20	0,08 – 0,19 – 0,30	0,12 – 0,235 – 0,35	0,16 – 0,28 – 0,40	0,20 – 0,325 – 0,45
f_k mm/U	0,06 – 0,11 – 0,16	0,08 – 0,16 – 0,24	0,12 – 0,21 – 0,30	0,16 – 0,28 – 0,40	0,20 – 0,325 – 0,45
a_p max	0,20 – 0,45 – 0,70	0,25 – 0,75 – 1,25	0,40 – 1,10 – 1,80	0,60 – 1,55 – 2,50	0,80 – 1,9 – 3,00

Geometrie T1 / Geometry T1 / Geometria T1

	Schneideinsatz / Insert / Insetto			
	SE24 – 20....	SE24 – 30....	SE24 – 40....	SE24 – 50....
f_v mm/U	0,03 – 0,075 – 0,12	0,05 – 0,125 – 0,20	0,10 – 0,17 – 0,24	0,12 – 0,21 – 0,30
f_n mm/U	0,03 – 0,115 – 0,20	0,05 – 0,15 – 0,25	0,10 – 0,20 – 0,30	0,16 – 0,28 – 0,40
f_k mm/U	0,06 – 0,13 – 0,20	0,08 – 0,19 – 0,30	0,12 – 0,26 – 0,40	0,16 – 0,33 – 0,50
a_p max	0,02 – 0,36 – 0,70	0,25 – 0,75 – 1,25	0,40 – 1,10 – 1,80	0,60 – 1,55 – 2,50

Geometrie ALU / Geometry ALU / Geometria ALU

	Schneideinsatz / Insert / Insetto	
	SE24 – 20....	SE24 – 30....
f_v mm/U	0,02 – 0,085 – 0,15	0,03 – 0,115 – 0,20
f_n mm/U	0,02 – 0,11 – 0,2	0,02 – 0,135 – 0,25
f_k mm/U	0,06 – 0,13 – 0,20	0,08 – 0,14 – 0,30
a_p max	0,20 – 0,60 – 1,00	0,25 – 0,875 – 1,5

Die Tabellenwerte sind Richtwerte. Es kann notwendig sein, die Werte den jeweiligen Bearbeitungsumständen anzupassen.
 The recommended cutting data are only approximate values. It may be necessary to adjust them to each individual machining application.
 I dati indicati in tabella sono valori approssimati. Può essere necessario adattarli alle singole applicazioni di lavorazione.

Empfohlene Schnittwerte

2

Werkstoff- gruppe	Gliederung der Werkstoffhauptgruppen und Kennbuchstaben		Brinell-Härte	Zugfestigkeit (N/mm ²)	Zerspanungsgruppe	Schnittgeschwindigkeit V _c (m/min)			
						beschichtet			
						AM5040	AP2240	AP5020	
P	Unlegierter Stahl	C ≤ 0,25 % geglüht	125	428	P1	120 - 150 - 180	130 - 155 - 180	120 - 150 - 180	
		C > 0,25 ... ≤ 0,55 % geglüht	190	639	P2	80 - 115 - 150	110 - 145 - 180	80 - 115 - 150	
		C > 0,25 ... ≤ 0,55 % vergütet	210	708	P3	60 - 100 - 140	70 - 120 - 170	60 - 100 - 140	
		C > 0,55 % geglüht	190	639	P4	80 - 115 - 150	110 - 145 - 180	80 - 115 - 150	
		C > 0,55 % vergütet	300	1013	P5	60 - 100 - 140	70 - 120 - 170	60 - 100 - 140	
		Automatenstahl (kurzspanend) geglüht	220	745	P6	80 - 115 - 150	110 - 145 - 180	80 - 115 - 150	
	Niedrig legierter Stahl	geglüht	175	591	P7	80 - 120 - 160	120 - 150 - 180	80 - 125 - 170	
		vergütet	300	1013	P8	60 - 95 - 130	110 - 145 - 180	60 - 95 - 130	
		vergütet	380	1282	P9	60 - 95 - 130	110 - 145 - 180	60 - 95 - 130	
		vergütet	430	1477	P10	60 - 90 - 120	70 - 110 - 150	60 - 90 - 120	
Hochlegierter Stahl und hochlegierter Werkzeugstahl	geglüht	200	675	P11	80 - 110 - 140	90 - 130 - 170	80 - 110 - 140		
	gehärtet und angelassen	300	1013	P12	50 - 85 - 120	70 - 115 - 160	50 - 85 - 120		
	gehärtet und angelassen	400	1361	P13	50 - 85 - 120	70 - 115 - 160	50 - 85 - 120		
Nichtrostender Stahl	ferritisch / martensitisch, geglüht	200	675	P14	60 - 110 - 160	120 - 150 - 180	60 - 115 - 170		
	martensitisch, vergütet	330	1114	P15	50 - 75 - 100	60 - 80 - 100	50 - 75 - 100		
M	Nichtrostender Stahl	austenitisch, abgeschreckt	200	675	M1	60 - 90 - 120	100 - 110 - 120	60 - 90 - 120	
		austenitisch, ausscheidungsgehärtet (PH)	300	1013	M2	50 - 70 - 90	60 - 75 - 90	50 - 70 - 90	
		austenitisch-ferritisch, Duplex	230	778	M3	40 - 60 - 80	40 - 60 - 80	50 - 70 - 90	
K	Temperguss	ferritisch	200	675	K1	-	100 - 150 - 200	-	
		perritisch	260	867	K2	-	80 - 115 - 150	-	
	Grauguss	niedrige Festigkeit	180	602	K3	-	100 - 150 - 200	-	
		hohe Festigkeit / austenitisch	245	825	K4	-	90 - 135 - 180	-	
	Gusseisen mit Kugelgraphit	ferritisch	155	518	K5	-	100 - 130 - 160	-	
		perritisch	265	885	K6	-	70 - 105 - 140	-	
	GGV (CGI)		200	675	K7	-	100 - 150 - 200	-	
N	Aluminium-Knetlegierungen	nicht aushärtbar	30	-	N1	-	-	100 - 300 - 500	
		aushärtbar, ausgehärtet	100	343	N2	-	-	100 - 200 - 300	
		≤ 12 % Si, nicht aushärtbar	75	260	N3	-	-	100 - 300 - 500	
	Aluminium-Gusslegierungen	≤ 12 % Si, aushärtbar, ausgehärtet	90	314	N4	-	-	100 - 200 - 300	
		> 12 % Si, nicht aushärtbar	130	447	N5	-	-	100 - 150 - 200	
	Magnesiumlegierungen		70	250	N6	-	-	-	
	Kupfer und Kupferlegierungen (Bronze / Messing)	unlegiert, Elektrolytkupfer	100	343	N7	-	-	100 - 200 - 300	
		Messing, Bronze, Rotguss	90	314	N8	-	-	100 - 300 - 500	
		Cu-Legierung, kurzspanend	110	382	N9	-	-	100 - 200 - 300	
		hochfest, Ampco	300	1013	N10	-	-	-	
Nichtmetallische Werkstoffe	Thermoplaste (ohne abrasive Füllstoffe)	-	-	N11	-	-	80 - 130 - 180		
	Duroplaste (ohne abrasive Füllstoffe)	-	-	N12	-	-	80 - 130 - 180		
	Kunststoff glasfaserverstärkt GFRP	-	-	N13	-	-	60 - 105 - 150		
	Kunststoff kohlefaserverstärkt CFRP	-	-	N14	-	-	60 - 105 - 150		
	Kunststoff aramidfaserverstärkt AFRP	-	-	N15	-	-	60 - 105 - 150		
	Graphit (technisch)	80 Shore	-	N16	-	-	-		
S	Warmfeste Legierungen	Fe-Basis geglüht	200	675	S1	-	-	20 - 35 - 50	
		ausgehärtet	280	943	S2	-	-	20 - 30 - 40	
		geglüht	250	839	S3	-	-	15 - 20 - 25	
		Ni- oder Co-Basis ausgehärtet	350	1177	S4	-	-	10 - 15 - 20	
		gegossen	320	1076	S5	-	-	10 - 15 - 20	
	Titanlegierungen	Reintitan	200	675	S6	-	-	50 - 85 - 120	
		α- und β-Legierungen, ausgehärtet	375	1262	S7	-	-	30 - 40 - 50	
		β-Legierungen	410	1396	S8	-	-	25 - 35 - 45	
	Wolframlegierungen		300	1013	S9	-	-	-	
	Molybdänlegierungen		300	1013	S10	-	-	-	
H	Gehärteter Stahl	gehärtet und angelassen	50 HRC	-	H1	-	-	-	
		gehärtet und angelassen	55 HRC	-	H2	-	-	-	
		gehärtet und angelassen	60 HRC	-	H3	-	-	-	
	Gehärtetes Gusseisen	gehärtet und angelassen	55 HRC	-	H4	-	-	-	

Die Tabellenwerte sind Richtwerte.
Es kann notwendig sein, die Werte den jeweiligen Bearbeitungsumständen anzupassen.

		unbeschichtet
	AP5030	AN1015
	120 - 150 - 180	-
	80 - 115 - 150	-
	60 - 100 - 140	-
	80 - 115 - 150	-
	60 - 100 - 140	-
	80 - 115 - 150	-
	80 - 125 - 170	-
	60 - 95 - 130	-
	60 - 95 - 130	-
	60 - 90 - 120	-
	80 - 110 - 140	-
	50 - 85 - 120	-
	50 - 85 - 120	-
	60 - 115 - 170	-
	50 - 75 - 100	-
	60 - 90 - 120	-
	50 - 70 - 90	-
	45 - 65 - 85	-
	-	140 - 170 - 200
	-	120 - 140 - 160
	-	120 - 140 - 160
	-	100 - 125 - 150
	-	130 - 150 - 170
	-	90 - 110 - 130
	-	140 - 170 - 200
	-	300 - 400 - 500
	-	200 - 250 - 300
	-	100 - 300 - 500
	-	100 - 200 - 300
	-	100 - 150 - 200
	-	-
	-	150 - 275 - 300
	-	200 - 350 - 500
	-	150 - 275 - 300
	-	-
	-	80 - 130 - 180
	-	80 - 130 - 180
	-	60 - 105 - 150
	-	60 - 105 - 150
	-	60 - 105 - 150
	-	-
	20 - 35 - 50	30 - 40 - 45
	20 - 30 - 40	20 - 30 - 35
	15 - 20 - 25	15 - 20 - 25
	10 - 15 - 20	10 - 15 - 20
	10 - 15 - 20	10 - 15 - 20
	50 - 85 - 120	60 - 90 - 120
	30 - 40 - 50	30 - 40 - 50
	25 - 35 - 45	25 - 35 - 45
	-	-
	-	-
	-	-
	-	-
	-	-

Recommended cutting data

2

Material group	Structure of the material groups and identification letters		Brinell hardness HB	Tensile strength Rm (N/mm ²)	Chipping group	Cutting speed V _c (m/min)			
						coated			
						AM5040	AP2240	AP5020	
P	Unalloyed steel	C ≤ 0.25 % annealed	125	428	P1	120 - 150 - 180	130 - 155 - 180	120 - 150 - 180	
		C > 0.25 ... ≤ 0.55 % annealed	190	639	P2	80 - 115 - 150	110 - 145 - 180	80 - 115 - 150	
		C > 0.25 ... ≤ 0.55 % hardened and tempered	210	708	P3	60 - 100 - 140	70 - 120 - 170	60 - 100 - 140	
		C > 0.55 % annealed	190	639	P4	80 - 115 - 150	110 - 145 - 180	80 - 115 - 150	
		C > 0.55 % hardened and tempered	300	1013	P5	60 - 100 - 140	70 - 120 - 170	60 - 100 - 140	
		Machining steel (short-chipping) tempered	220	745	P6	80 - 115 - 150	110 - 145 - 180	80 - 115 - 150	
	Low alloyed steel	annealed	175	591	P7	80 - 120 - 160	120 - 150 - 180	80 - 125 - 170	
		hardened and tempered	300	1013	P8	60 - 95 - 130	110 - 145 - 180	60 - 95 - 130	
		hardened and tempered	380	1282	P9	60 - 95 - 130	110 - 145 - 180	60 - 95 - 130	
		hardened and tempered	430	1477	P10	60 - 90 - 120	70 - 110 - 150	60 - 90 - 120	
	High alloyed steel and high alloyed tool steel	annealed	200	675	P11	80 - 110 - 140	90 - 130 - 170	80 - 110 - 140	
		hardened	300	1013	P12	50 - 85 - 120	70 - 115 - 160	50 - 85 - 120	
		hardened	400	1361	P13	50 - 85 - 120	70 - 115 - 160	50 - 85 - 120	
	Stainless steel	ferritic / martensitic, annealed	200	675	P14	60 - 110 - 160	120 - 150 - 180	60 - 115 - 170	
		martensitic, hardened and tempered	330	1114	P15	50 - 75 - 100	60 - 80 - 100	50 - 75 - 100	
M	Stainless steel	austenitic, chilled	200	675	M1	60 - 90 - 120	100 - 110 - 120	60 - 90 - 120	
		austenitic, precipitation-hardened (PH)	300	1013	M2	50 - 70 - 90	60 - 75 - 90	50 - 70 - 90	
		austenitic-ferritic, Duplex	230	778	M3	40 - 60 - 80	40 - 60 - 80	50 - 70 - 90	
K	Malleable cast iron	ferritic	200	675	K1	-	100 - 150 - 200	-	
		pearlitic	260	867	K2	-	80 - 115 - 150	-	
	Cast iron	low tensile strength	180	602	K3	-	100 - 150 - 200	-	
		high tensile strength / austenitic	245	825	K4	-	90 - 135 - 180	-	
	Cast iron with nodular graphite	ferritic	155	518	K5	-	100 - 130 - 160	-	
		pearlitic	265	885	K6	-	70 - 105 - 140	-	
GGV (CGI)		200	675	K7	-	100 - 150 - 200	-		
N	Aluminium alloys long chipping	not heat treatable	30	-	N1	-	-	100 - 300 - 500	
		heat treatable, heat treated	100	343	N2	-	-	100 - 200 - 300	
		≤ 12 % Si, not heat treatable	75	260	N3	-	-	100 - 300 - 500	
	Casted aluminium alloys	≤ 12 % Si, aushärtbar, ausgehärtet	90	314	N4	-	-	100 - 200 - 300	
		> 12 % Si, not heat treatable	130	447	N5	-	-	100 - 150 - 200	
	Magnesium alloys		70	250	N6	-	-	-	
	Copper and copper alloys (Brass / Bronze)	Unalloyed, elektrolyte copper	100	343	N7	-	-	100 - 200 - 300	
		Brass, Bronze	90	314	N8	-	-	100 - 300 - 500	
		Cu-alloys, short-chipping	110	382	N9	-	-	100 - 200 - 300	
		High-tensile, Ampco	300	1013	N10	-	-	-	
	Non-ferrous materials	Lead alloys (without abrasive filling material)	-	-	N11	-	-	80 - 130 - 180	
		Duroplastic (without abrasive filling material)	-	-	N12	-	-	80 - 130 - 180	
		Plastic glas fibre reinforced GFRP	-	-	N13	-	-	60 - 105 - 150	
		Plastic carbon fibre reinforced CFRP	-	-	N14	-	-	60 - 105 - 150	
		Plastic aramid fibre reinforced AFRP	-	-	N15	-	-	60 - 105 - 150	
Graphite (tech.)			80 Shore	-	N16	-	-	-	
S	High temperature resistant alloys	Fe-Basis	annealed	200	675	S1	-	-	20 - 35 - 50
			heat treated	280	943	S2	-	-	20 - 30 - 40
		Ni- or Co-alloyed	annealed	250	839	S3	-	-	15 - 20 - 25
			heat treated	350	1177	S4	-	-	10 - 15 - 20
			casting	320	1076	S5	-	-	10 - 15 - 20
	Titanium alloys	Pure titan	200	675	S6	-	-	50 - 85 - 120	
		α- and β-alloys, heat treated	375	1262	S7	-	-	30 - 40 - 50	
	β-alloys	410	1396	S8	-	-	25 - 35 - 45		
	Wolfram alloys		300	1013	S9	-	-	-	
	Molybdän alloys		300	1013	S10	-	-	-	
H	Hardened steel	hardened	50 HRC	-	H1	-	-	-	
		hardened	55 HRC	-	H2	-	-	-	
		hardened	60 HRC	-	H3	-	-	-	
	Hardened cast iron	hardened	55 HRC	-	H4	-	-	-	

The recommended cutting data are only approximate values. It may be necessary to adjust them to each individual machining application.

		uncoated
	AP5030	AN1015
	120 - 150 - 180	-
	80 - 115 - 150	-
	60 - 100 - 140	-
	80 - 115 - 150	-
	60 - 100 - 140	-
	80 - 115 - 150	-
	80 - 125 - 170	-
	60 - 95 - 130	-
	60 - 95 - 130	-
	60 - 90 - 120	-
	80 - 110 - 140	-
	50 - 85 - 120	-
	50 - 85 - 120	-
	60 - 115 - 170	-
	50 - 75 - 100	-
	60 - 90 - 120	-
	50 - 70 - 90	-
	45 - 65 - 85	-
	-	140 - 170 - 200
	-	120 - 140 - 160
	-	120 - 140 - 160
	-	100 - 125 - 150
	-	130 - 150 - 170
	-	90 - 110 - 130
	-	140 - 170 - 200
	-	300 - 400 - 500
	-	200 - 250 - 300
	-	100 - 300 - 500
	-	100 - 200 - 300
	-	100 - 150 - 200
	-	-
	-	150 - 275 - 300
	-	200 - 350 - 500
	-	150 - 275 - 300
	-	-
	-	80 - 130 - 180
	-	80 - 130 - 180
	-	60 - 105 - 150
	-	60 - 105 - 150
	-	60 - 105 - 150
	-	-
	20 - 35 - 50	30 - 40 - 45
	20 - 30 - 40	20 - 30 - 35
	15 - 20 - 25	15 - 20 - 25
	10 - 15 - 20	10 - 15 - 20
	10 - 15 - 20	10 - 15 - 20
	50 - 85 - 120	60 - 90 - 120
	30 - 40 - 50	30 - 40 - 50
	25 - 35 - 45	25 - 35 - 45
	-	-
	-	-
	-	-
	-	-
	-	-

Parametri di taglio suggeriti

2

Gruppo materiale	Struttura dei gruppi di materiali e lettere di riferimento			Durezza Brinell	Resistenza Rm (N/mm ²)	Gruppo di lavoro	Velocità di taglio V _c (m/min)			
							rivestito			
							AM5040	AP2240	AP5020	
P	Acciai non legato	C ≤ 0,25 %	ricotto	125	428	P1	120 - 150 - 180	130 - 155 - 180	120 - 150 - 180	
		C > 0,25 ... ≤ 0,55 %	ricotto	190	639	P2	80 - 115 - 150	110 - 145 - 180	80 - 115 - 150	
		C > 0,25 ... ≤ 0,55 %	bonificato	210	708	P3	60 - 100 - 140	70 - 120 - 170	60 - 100 - 140	
		C > 0,55 %	ricotto	190	639	P4	80 - 115 - 150	110 - 145 - 180	80 - 115 - 150	
		C > 0,55 %	bonificato	300	1013	P5	60 - 100 - 140	70 - 120 - 170	60 - 100 - 140	
	Acciai debolmente legati	Acciaio (truciolo corto)	ricotto	220	745	P6	80 - 115 - 150	110 - 145 - 180	80 - 115 - 150	
			ricotto	175	591	P7	80 - 120 - 160	120 - 150 - 180	80 - 125 - 170	
			bonificato	300	1013	P8	60 - 95 - 130	110 - 145 - 180	60 - 95 - 130	
			bonificato	380	1282	P9	60 - 95 - 130	110 - 145 - 180	60 - 95 - 130	
			bonificato	430	1477	P10	60 - 90 - 120	70 - 110 - 150	60 - 90 - 120	
Acciai fortemente legati e acciai da utensili		ricotto	200	675	P11	80 - 110 - 140	90 - 130 - 170	80 - 110 - 140		
		temprato e rinvenuto	300	1013	P12	50 - 85 - 120	70 - 115 - 160	50 - 85 - 120		
		temprato e rinvenuto	400	1361	P13	50 - 85 - 120	70 - 115 - 160	50 - 85 - 120		
Acciai inossidabili		ferritico / martensitico, ricotto	200	675	P14	60 - 110 - 160	120 - 150 - 180	60 - 115 - 170		
		martensitico, bonificato	330	1114	P15	50 - 75 - 100	60 - 80 - 100	50 - 75 - 100		
M	Acciai inossidabili		austenitico, trattato o temperato	200	675	M1	60 - 90 - 120	100 - 110 - 120	60 - 90 - 120	
			austenitico, indurimento per precipitazione (PH)	300	1013	M2	50 - 70 - 90	60 - 75 - 90	50 - 70 - 90	
			austenitico-ferritico, Duplex	230	778	M3	40 - 60 - 80	40 - 60 - 80	50 - 70 - 90	
K	Ghisa temprata		ferritico	200	675	K1	-	100 - 150 - 200	-	
			perlitica	260	867	K2	-	80 - 115 - 150	-	
	Ghisa grigia		bassa resistenza	180	602	K3	-	100 - 150 - 200	-	
			alta resistenza / austenitico	245	825	K4	-	90 - 135 - 180	-	
	Ghisa sferoidale		ferritico	155	518	K5	-	100 - 130 - 160	-	
			perlitica	265	885	K6	-	70 - 105 - 140	-	
	GGV (CGI)			200	675	K7	-	100 - 150 - 200	-	
N	Leghe di Alluminio stampato		non invecchiato	30	-	N1	-	-	100 - 300 - 500	
			rinvenuto, invecchiato	100	343	N2	-	-	100 - 200 - 300	
			≤ 12 % Si, non invecchiato	75	260	N3	-	-	100 - 300 - 500	
	Leghe di Alluminio da fusione		≤ 12 % Si, rinvenuto, invecchiato	90	314	N4	-	-	100 - 200 - 300	
			> 12 % Si, non invecchiato	130	447	N5	-	-	100 - 150 - 200	
		Leghe di magnesio			70	250	N6	-	-	-
	Rame e Leghe di Rame (Bronzo / Ottone)		Non legati, Rame Elettrolitico	100	343	N7	-	-	100 - 200 - 300	
			Ottone, Bronzo	90	314	N8	-	-	100 - 300 - 500	
			Leghe Cu, truciolo corto	110	382	N9	-	-	100 - 200 - 300	
			Alta resistenza, Ampco	300	1013	N10	-	-	-	
Materiali non metallici		Leghe al piombo (senza materiale di riempimento abrasivo)	-	-	N11	-	-	80 - 130 - 180		
		Duroplastico (senza materiale di riempimento abrasivo)	-	-	N12	-	-	80 - 130 - 180		
		Plastica rinforzata in fibra di vetro GFRP	-	-	N13	-	-	60 - 105 - 150		
		Plastica rinforzata in fibra di carbonio CFRP	-	-	N14	-	-	60 - 105 - 150		
		Plastica rinforzata in fibra aramidica AFRP	-	-	N15	-	-	60 - 105 - 150		
		Grafite (tecnico)			80 Shore	-	-	-		
S	Leghe resistenti al calore	Base-Fe	ricotto	200	675	S1	-	-	20 - 35 - 50	
			invecchiato	280	943	S2	-	-	20 - 30 - 40	
		Base Ni o Co	ricotto	250	839	S3	-	-	15 - 20 - 25	
			invecchiato	350	1177	S4	-	-	10 - 15 - 20	
			da fusione	320	1076	S5	-	-	10 - 15 - 20	
	Leghe di Titanio		Titanio puro	200	675	S6	-	-	50 - 85 - 120	
			Leghe α e β, invecchiato	375	1262	S7	-	-	30 - 40 - 50	
			Leghe β	410	1396	S8	-	-	25 - 35 - 45	
		Leghe di tungsteno			300	1013	S9	-	-	-
		Leghe di molibdeno			300	1013	S10	-	-	-
H	Acciaio Temprato		temprato e rinvenuto	50 HRC	-	H1	-	-	-	
			temprato e rinvenuto	55 HRC	-	H2	-	-	-	
			temprato e rinvenuto	60 HRC	-	H3	-	-	-	
		Ghisa Temprata	temprato e rinvenuto	55 HRC	-	H4	-	-	-	

I dati indicati in tabella sono valori approssimati. Può essere necessario adattarli alle singole applicazioni di lavorazione.

		non rivestito
	AP5030	AN1015
	120 - 150 - 180	-
	80 - 115 - 150	-
	60 - 100 - 140	-
	80 - 115 - 150	-
	60 - 100 - 140	-
	80 - 115 - 150	-
	80 - 125 - 170	-
	60 - 95 - 130	-
	60 - 95 - 130	-
	60 - 90 - 120	-
	80 - 110 - 140	-
	50 - 85 - 120	-
	50 - 85 - 120	-
	60 - 115 - 170	-
	50 - 75 - 100	-
	60 - 90 - 120	-
	50 - 70 - 90	-
	45 - 65 - 85	-
	-	140 - 170 - 200
	-	120 - 140 - 160
	-	120 - 140 - 160
	-	100 - 125 - 150
	-	130 - 150 - 170
	-	90 - 110 - 130
	-	140 - 170 - 200
	-	300 - 400 - 500
	-	200 - 250 - 300
	-	100 - 300 - 500
	-	100 - 200 - 300
	-	100 - 150 - 200
	-	-
	-	150 - 275 - 300
	-	200 - 350 - 500
	-	150 - 275 - 300
	-	-
	-	80 - 130 - 180
	-	80 - 130 - 180
	-	60 - 105 - 150
	-	60 - 105 - 150
	-	60 - 105 - 150
	-	-
	20 - 35 - 50	30 - 40 - 45
	20 - 30 - 40	20 - 30 - 35
	15 - 20 - 25	15 - 20 - 25
	10 - 15 - 20	10 - 15 - 20
	10 - 15 - 20	10 - 15 - 20
	50 - 85 - 120	60 - 90 - 120
	30 - 40 - 50	30 - 40 - 50
	25 - 35 - 45	25 - 35 - 45
	-	-
	-	-
	-	-
	-	-
	-	-

Allgemein / General /
Indicazioni di base

Grundsätzlich sollte darauf geachtet werden, dass das Stechwerkzeug so stabil wie möglich ausgewählt wird. Dadurch können Vibrationen verhindert und die Standzeit gesteigert werden.

Bei der Auswahl der Stechplatten ist zu beachten:

- Die Stechbreite EB in mm
- Die Geometrie für die Bearbeitung
- Der Eckenradius

Die Stechbreite sollte so schmal wie möglich und so breit wie nötig ausgewählt werden. Durch die Reduzierung der Stechbreite wird auch die Schnittkraft reduziert und kann in der Massenfertigung zudem auch zu enormen Einsparungen an Materialkosten führen. Nach Möglichkeit sind neutrale Schneiden einzusetzen, die eine bessere Spanbildung, geringere Abdrängkräfte und höhere Standzeiten erreichen.

Pay attention to selection of the correct tools. Tools should have minimum overhang to reduce vibrations and increase of tool life.

When selecting inserts, consider:

- Parting-off width in mm
- Chip breaker for the material
- Approach angle and corner radius

Select insert width as narrow as possible and as wide as necessary. By reducing the insert width, the cutting forces are reduced and especially important when mass producing less material is wasted. Whenever possible it is always recommended to use neutral inserts that offer better swarf control and tool life.

Scegliere sempre l'utensile più compatto possibile per una maggiore stabilità. Grazie a questo le vibrazioni vengono ridotte, la lavorazione è più stabile e la durata inserto aumentata.

Nella scelta dell'inserto di scanalatura è bene valutare:

- La larghezza di taglio in mm
- La forma di rompitruciolo
- L'angolo di taglio ed il raggio di punta

La larghezza della troncatura deve essere il più stretto possibile – scegliere inserti proporzionati alla misura da realizzare. Riducendo la larghezza di taglio, si riduce la forza di taglio e può risultare in un enorme risparmio dei costi delle

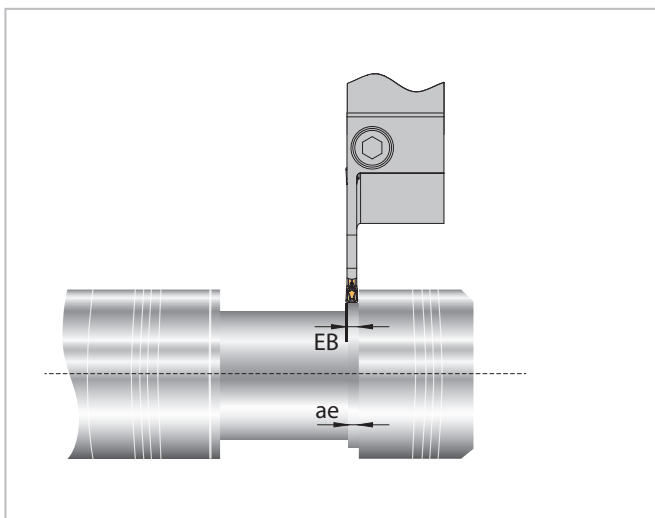
Hinweise zum Einstechen / Recommendations for grooving /
Suggerimenti per la troncatura

Beim seitlich versetzten Einstechen sollte die Breite „ae“ mindestens 70 % der Stechbreite „EB“ betragen.

When grooving with an axial displacement the width “ae” should be a minimum of 70 % of the groove width “EB”.

Per lavorazioni senza appoggio laterale assicurarsi che la larghezza di lavoro “ae” sia almeno il 70 % della larghezza inserto “EB”.

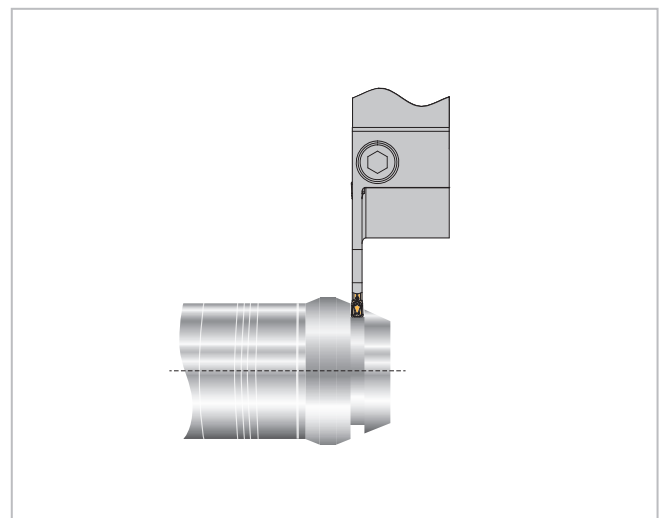

Beim Einstechen an schrägen Flächen muss der Vorschub beim Anschnitt um ca. 20 % bis 50 % reduziert werden.

When grooving into an angled surface reduce feed rate by 20 – 50 % until in full cut.

La scanalatura su superfici inclinate deve prevedere una riduzione dell' avanzamento tra il 20 % ed il 50 %.

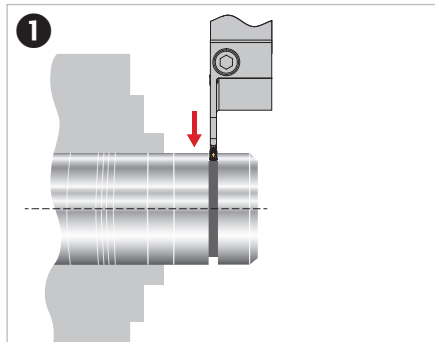
Fasen und Abstechen / Chamfering and parting-off /
Sequenza per smussatura e troncatura

1. Vorstechen
1. Pre-grooving
1. Pre-scanalatura

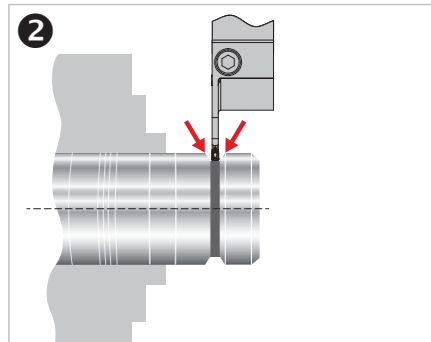

2. Fasen
2. Chamfering
2. Smusso

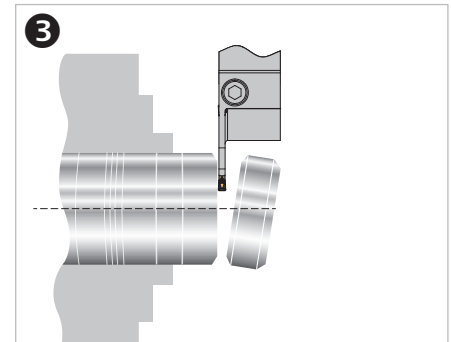

3. Abstechen
3. Parting-off
3. Troncatura

2

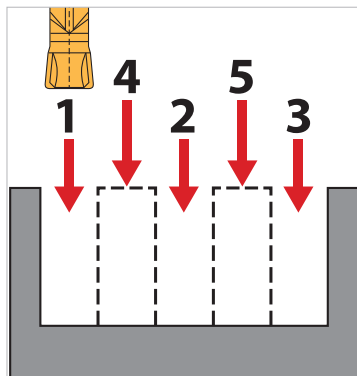
Mehrfacheinstechen
Multiple grooving
Scanalatura a tuffo

Zuerst sind die vollen Nuten zu bearbeiten. Einstiche 1, 2 und 3. Danach werden die Stege 4 und 5 bearbeitet.

Dadurch werden die Eckenradien geschützt und die Späne in die Mitte des Spanbrechers abgeführt. Stegbreite 0,6 bis 0,8 x Stechbreite EB.

First the full grooves are machined. Grooves 1, 2 and 3, thereafter 4 and 5. This protects the corner radius and the swarf comes off the centre of the chip breaker. Widths of 4 and 5 should be 0.6 – 0.8 x parting-off width (EB).

Prima di procedere, valutare il tipo di gola e scegliere la dimensione inserto adatta per larghezza e profondità. Eseguire scanalature 1, 2 e 3; successivamente 4 e 5.

In tal modo l'inserto lavora con appoggio sui fianchi, in quelle successive senza appoggio ma solo sul rompitruciolo centrale. Prevedere profondità di gola ridotte e ripetere l'operazione fino alla massima profondità.

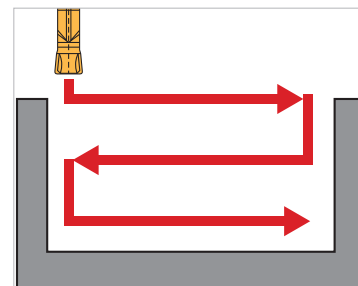
Stechdrehen
Groove turning
Scanalatura di copiatura

Die Schnitttiefe a_p richtet sich nach der Stechbreite, dem zu zerspanenden Werkstoff und der Schneidkantenlänge bzw. Aufpannsituation.

Faustformel:
 $a_p \text{ max.} = EB \times 0,7$
 $a_p \text{ min.} = \text{Eckenradius „R“}$

The groove depth (a_p) depends on the parting-off width, material and the edge length of the inserts.

General rule:
 $a_p \text{ max.} = EB \times 0.7$
 $a_p \text{ min.} = \text{corner radius "R"}$

La profondità di passata è determinata dalla larghezza di taglio dell'inserto, dalla tipologia di materiale e dalla lunghezza (stabilità) del portainserito.

Regola generale:
 $a_p \text{ max.} = EB \times 0,7$
 $a_p \text{ min.} = \text{Raggio "R"}$

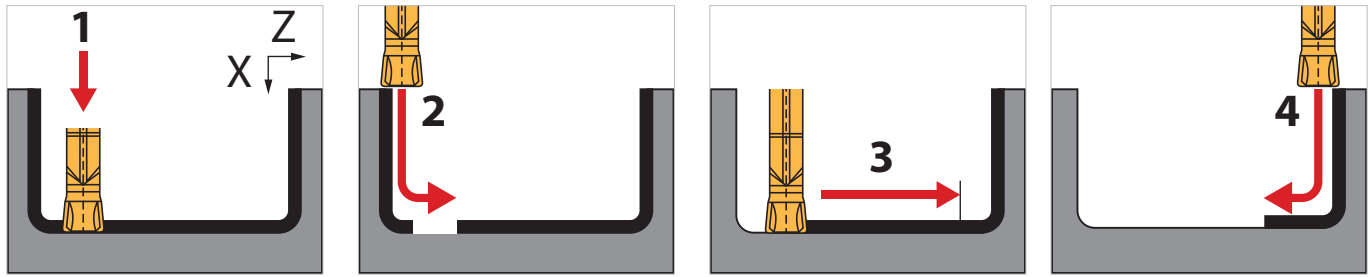
Nut-Fertigbearbeitung / Groove finishing machining / Sequenza per la finitura di gole

2

Vorsicht ist geboten bei der Fertigbearbeitung, da die Schneidplatte um den Radiusbereich am Grund fährt und die meisten Bewegungen in der Z-Richtung erfolgen.

Dies führt zur Bildung dünner Späne und kann aufgrund von Vibrationen zur Behinderung des Prozesses führen.

Durch Einhaltung des dargestellten Bearbeitungsablaufes lässt sich dies verhindern, wobei die axiale und radiale Schnitttiefe zwischen 0,5 und 1,0 mm liegen muss.

Take care when finishing, the radius of the insert moves mainly in the z-axis and this can produce very thin swarf which can lead to vibrations and poor surface finish.

If using the machine path shown, this can be avoided, axial and radial cutting depth should be between 0.5 – 1.0 mm.

Il ciclo di finitura gola prevede una sequenza che eviti la formazione di anelli di bave. Scegliere forme di rompitruciolo con controllo truciolo anche per avanzamenti composti (copiatura) e non solo e non solo in Z come per tutti gli inserti di tronatura.

Evitare la formazione di trucioli sottili e lunghi e di vibrazioni.

La sequenza rappresentata indica il metodo suggerito di lavoro per una situazione tipo prevedendo profondità di passata tra 0,5 e 1,0 mm.

NC-Stechedrehsystem*NC-Groove turning system*

NC-Sistema di scanalatura e copiatura

Stechedrehsystem zum Außen- und Innenstechdrehen

Groove turning system for external and internal grooving and copy-turning

Sistema di scanalatura e copiatura modulare esterna e interna

• Systemvorstellung	• Introduction	• Caratteristiche del sistema	200 – 201
• Grundhalter	• Basic holders	• Corpo utensili	202 – 246
– Werkzeugauswahl	– Tool shank options	– Tipologie di corpo utensile	202
– Grundhalter – Außenbearbeitung	– Basic holders – External machining	– Corpo utensili – Steli per lavorazione esterna	203 – 235
– SAN Monoblockhalter	– SAN Monoblock holders	– SAN Utensili monoblocco	236
– Grundhalter – Innenbearbeitung	– Basic holders – Internal machining	– Corpo utensili – Steli per lavorazione interna	237 – 245
– SIN Bohrstangen	– SIN Boring bars	– SIN Barenì	246
• Schneideinsätze	• Inserts	• Inerti	247 – 259
– Geometrie	– Geometry	– Geometria	247 – 248
– Sortenbeschreibung	– Grade description	– Descrizione delle Qualità	249 – 250
– Schneideinsätze	– Inserts	– Inerti	251 – 259
• Ersatzteile und Zubehör	• Spare parts and accessories	• Ricambi e accessori	260 – 261
• Schnittwerte	• Cutting data	• Parametri di taglio	262 – 269
• Anwendungshinweise	• Application reference	• Suggestimenti tecnici	270 – 277



Universal Stechsystem für die Außen- und Innenbearbeitung beim Radialen, Axialen und Kontra Stechen

External and internal groove turning system for radial, axial and contra grooving applications

Sistema di scanalatura universale per lavorazione esterna e interna radiale, assiale e kontra

3

Grundhalter – Außenbearbeitung

Basic holders – External machining

Corpo utensili – Steli per lavorazione esterna



Grundhalter – Innenbearbeitung

Basic holders – Internal machining

Corpo utensili – Steli per lavorazione interna



Systemvorstellung

Ein Werkzeugsystem, das höchsten Ansprüchen gerecht wird. Einfachste Montage verbunden mit höchster Vielfalt. Ein Werkzeughalter wird durch schnellen Wechsel der einzelnen Komponenten zu einem universell einsetzbaren Werkzeugsystem.

Grundhalter – Außenbearbeitung

- Schäfte von 8 x 8 bis 32 x 32 mm
- Stechbreiten 0,55 bis 10 mm
- Capto/UTS/KM/VDI Aufnahmen

Grundhalter – Innenbearbeitung

- Schäfte von Ø 12 bis Ø 50 mm
- D_{\min} ab Ø 16 mm
- Stechbreiten 0,55 bis 10 mm

Introduction

A tool system that meets the highest requirements. Extremely easy handling with maximum variety. One tool holder becomes universally usable tooling system due to the rapid changing of the individual components.

Basic holders – External machining

- Shank sizes from 8 x 8 to 32 x 32 mm
- Groove widths from 0.55 to 10 mm
- Capto/UTS/KM/VDI adaptors

Basic holders – Internal machining

- Shank sizes from Ø 12 to Ø 50 mm
- D_{\min} from Ø 16 mm
- Groove widths from 0.55 to 10 mm

Descrizione

Un sistema di utensili rivolto alle lavorazioni più esigenti. Montaggio semplice e modulare. Grazie al cambio veloce dei singoli componenti diventa un sistema di utensili per un uso universale.

Corpo utensili – Steli per lavorazione esterna

- Steli da 8 x 8 fino a 32 x 32 mm
- Larghezza di taglio da 0,55 a 10 mm
- Capto/UTS/KM/VDI attacchi

Corpo utensili – Steli per lavorazione interna

- Steli da Ø 12 fino a Ø 50 mm
- D_{\min} da Ø 16 mm
- Larghezza di taglio da 0,55 a 10 mm

Fakten

- Verschiedene Stechdrehwerkzeuge für den Einsatz mit speziell entwickelten Schneideinsätzen
- Modulares Stechdrehsystem in vielen Ausführungen mit einem Grundhalter
- Für die Innen- und Außenbearbeitung
- Speziell entwickelte Geometrien für
 - Aluminiumbearbeitung
 - Sicherungseinstiche
 - Späneinschnürung
- SIN (Bohrstangen für die Innenbearbeitung, Einsatz für kleine Bohrungen)

Features

- Various cutting tools for use with specially developed cutting inserts
- Modular grooving system – various capabilities with one single holder
- For internal and external machining
- Special geometries for
 - Aluminum
 - Chip grooves
 - Chip breaking and constriction
- SIN (internal boring bars with coolant directly on cutting edge for smaller bores)

Caratteristiche

- Diverse composizioni di utensili da utilizzare con inserti specifici
- Sistema modulare: diverse versioni con un solo stelo
- Per lavorazioni esterne e interne
- Geometrie specifiche per
 - Alluminio
 - Sedi seeger e OR
 - Controllo truciolo
- SIN (bareni per gole integrale con adduzione diretta sul tagliente)

3



Grundhalter – Außenbearbeitung / *Basic holders – External machining* / *Corpo utensili – Steli per lavorazione esterna*

Seite/Page/Pagina **203 – 235**



SAN Monoblockhalter / *SAN Monoblock holders* / *SAN Utensili monoblocco*

Seite/Page/Pagina **236**



Grundhalter – Innenbearbeitung / *Basic holders – Internal machining* / *Corpo utensili – Steli per lavorazione interna*

Seite/Page/Pagina **237 – 245**



SIN Bohrstangen / *SIN Boring bars* / *SIN Baren*

Seite/Page/Pagina **246**

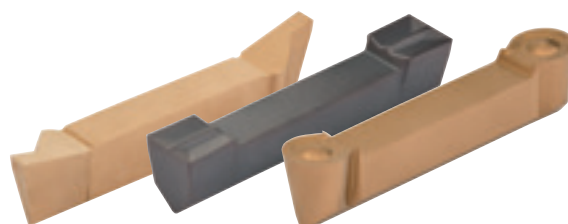

Schneideinsätze / *Inserts* / *Inserti*

Seite/Page/Pagina **251 – 259**

Radial-Stechdrehen gerade / Radial groove turning straight /
Utensile dritto - Scanalatura e copiatura radiale

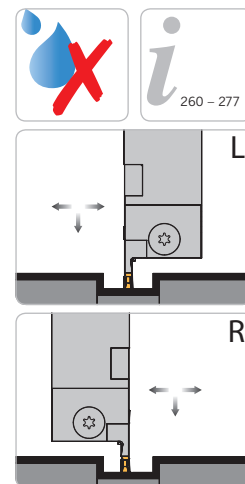
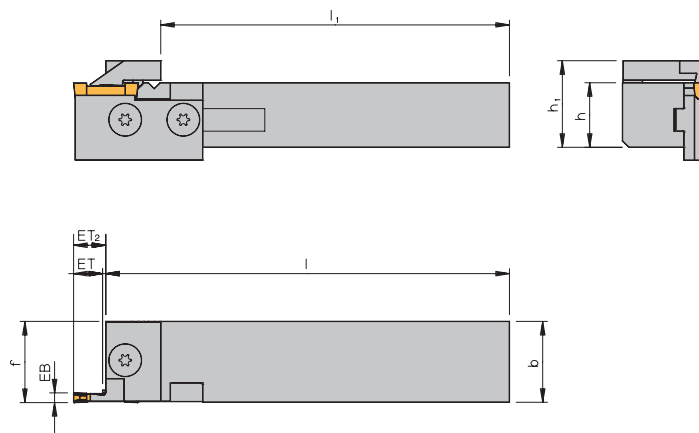

Rechte Ausführung abgebildet
Right-hand execution shown
Versione destra in figura



Trägerwerkzeuge / Holders / Utensili

Bezeichnung Designation Articolo	h	b	l	h ₁	l ₁	f	PG 12
71216L/R	12	16	90	17	81	16	●
71616L/R	16	16	110	21	101	16	●
72020L/R	20	20	125	25	116	20	●
72025L/R*	20	25	125	27	113	25	●
72525L/R*	25	25	150	32	138	25	●
72525L-M	25	25	150	30	141	25	●
73225L/R*	32	25	170	39	158	25	●
373225L/R	32	25	170	41	145	26	●
373232L/R	32	32	170	40	145	33	●

*Bei Stechbreite 6 mm --> f = b + 0,5; übrige Stechbreiten f = b

*For width of cut 6 mm --> f = b + 0.5; for all others f = b

*Per larghezza di taglio di 6 mm --> f = b + 0,5; altre larghezze f = b

Grundhalter und Zubehör / Basic holder and accessories / Corpo utensile e accessori

Grundhalter Basic holder Corpo utensile	EB	ET	ET ₂	U-Platte Support blade Lama	Klemme Clamp Staffa	Schneideinsatz Insert Inserto
71216L/R	0,5 - 1,85	= EB	= EB	UA2/471 R/L	KAM2 R/L	2-../471 R/L
71616L/R	0,5 - 3,08	= EB	= EB	UA3/471 R/L	KAM3 R/L	3M-../471 R/L
72020L/R	2,00	8,0	8,0	10208 R/L	KAM2 R/L	212....
72525L/R-M	3,00	12,0	12,0	10312 R/L	KAM3 R/L	316....
72025L/R 72525L/R 73225L/R	0,5 - 3,08	= EB	= EB	UA471 R/L	KA3 R/L	3-../471 R/L
	3,00	9,5	9,5	20310 R/L	KA3 R/L	320....
	4,00	11,5	11,5	20412 R/L	KA4 R/L	422....
	5,00	14,5	14,5	20515 R/L	KA5 R/L	525....
	6,00	19,5	19,5	20620 R/L	KA6 R/L	630....
	3,00	16,0	18,5	UT316 R/L	KT3 R/L	320....
	4,00	19,0	21,5	UT419 R/L	KT4 R/L	422....
	5,00	22,0	24,5	UT522 R/L	KT5 R/L	525....
6,00	27,0	29,5	UT627 R/L	KT6 R/L	630....	

Weiteres Zubehör auf der nächsten Seite
More accessories next page
Altri accessori nella pagina seguente

Grundhalter und Zubehör / Basic holder and accessories / Corpo utensile e accessori

Grundhalter Basic holder Corpo utensile	EB	ET	ET ₂	U-Platte Support blade Lama	Klemme Clamp Staffa	Schneideinsatz Insert Inserto
373225L/R 373232L/R	8,00	18,0	18,0	30817 R/L	KAK8 R/L	838....
	10,00	26,0	26,0	31025 R/L	KAK10 R/L	1046....
	8,00	32,5	32,5	UT832 R/L	KA8 R/L	838....
	10,00	40,5	40,5	UT1040 R/L	KA10 R/L	1046....

ET₂ = Stechtiefe kann auf Maß „ET₂“ erhöht werden.

ET₂ = Grooving depth can be increased to measure "ET₂".

ET₂ = La profondità di scanalatura può essere aumentata alla dimensione "ET₂".

Grundhalter werden mit Schrauben und Schlüssel geliefert, jedoch ohne U-Platte und Klemme.

Basic holders will be supplied with screws and key, however without support blade and clamp.

Gli steli sono forniti completi di viti e una chiave ma senza staffa e lama.

Achtung: Schwerverspannklemme für NC-Stechdrehen, bei unterbrochenen Schnitten oder Vibrationen, siehe Seite 212.

Attention: Heavy duty clamp for NC-Groove turning, at interrupted cuts or vibrations, please refer to page 212.

Attenzione: Staffa a serraggio rinforzata, per taglio interrotto o in caso di vibrazioni, vedere pagina 212.

Ersatzteile / Spare Parts / Ricambi

Trägerwerkzeug Holder Utensile	Schraube Screw Vite	Schlüssel Key Chiave
373225..-373232..	T206	T5120
71216..-71616..-72020..-72525..-M	T154	KS 1111
72025..-72525..-73225..	T205	T5120

3

Radial-Stechdrehen abgesetzt / Radial groove turning cranked / Utensile inclinato - Scanalatura e copiatura radiale

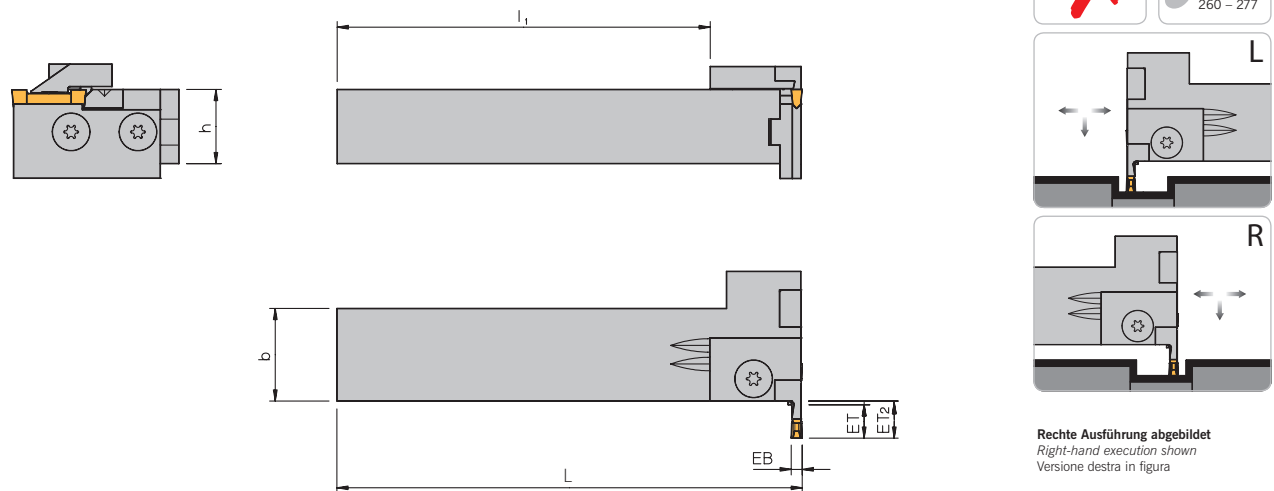

Trägerwerkzeuge / Holders / Utensili

Bezeichnung Designation Articolo	h	b	L	I ₁	PG 12
11616L/R	16	16	110	95	●
12020L/R	20	20	125	110	●
12525L/R-M	25	25	150	125	●
12025L/R	20	25	125	101	●
12525L/R	25	25	150	126	●
13232L/R	32	32	170	146	●
313232L/R	32	32	170	145	●

Grundhalter und Zubehör / Basic holder and accessories / Corpo utensile e accessori

Grundhalter Basic holder Corpo utensile	EB	ET	ET ₂	U-Platte Support blade Lama	Klemme Clamp Staffa	Schneideinsatz Insert Inserto
11616L/R 12020L/R 12525L/R-M	0,5 – 1,85	= EB	= EB	UA2/471 R/L	KAM2 R/L	2-../471 R/L
	0,5 – 3,08	= EB	= EB	UA3/471 R/L	KAM3 R/L	3M-../471 R/L
	2,00	8,0	8,0	10208 R/L	KAM2 R/L	212....
	3,00	12,0	12,0	10312 R/L	KAM3 R/L	316....
12025L/R 12525L/R 13232L/R	0,5 – 3,08	= EB	= EB	UA471 R/L	KA3 R/L	3-../471 R/L
	3,00	9,5	9,5	20310 R/L	KA3 R/L	320....
	4,00	11,5	11,5	20412 R/L	KA4 R/L	422....
	5,00	14,5	14,5	20515 R/L	KA5 R/L	525....
	6,00	19,5	19,5	20620 R/L	KA6 R/L	630....
	3,00	16,0	18,5	UT316 R/L	KT3 R/L	320....
	4,00	19,0	21,5	UT419 R/L	KT4 R/L	422....
	5,00	22,0	24,5	UT522 R/L	KT5 R/L	525....
313232L/R	8,00	18,0	18,0	30817 R/L	KAK8 R/L	838....
	10,00	26,0	26,0	31025 R/L	KAK10 R/L	1046....
	8,00	32,5	32,5	UT832 R/L	KA8 R/L	838....
	10,00	40,5	40,5	UT1040 R/L	KA10 R/L	1046....

ET₂ = Stechtiefe kann auf Maß „ET₂“ erhöht werden.
ET₂ = Grooving depth can be increased to measure "ET₂".
ET₂ = La profondità di scanalatura può essere aumentata alla dimensione "ET₂".

Grundhalter werden mit Schrauben und Schlüssel geliefert, jedoch ohne U-Platte und Klemme.
Basic holders will be supplied with screws and key, however without support blade and clamp.
Gli steli sono forniti completi di viti e una chiave ma senza staffa e lama.

Achtung: Schwerverspannklemme für NC-Stechdrehen, bei unterbrochenen Schnitten oder Vibrationen, siehe Seite 212.
Attention: Heavy duty clamp for NC-Groove turning, at interrupted cuts or vibrations, please refer to page 212.
Attenzione: Staffa a serraggio rinforzata, per taglio interrotto o in caso di vibrazioni, vedere pagina 212.

Ersatzteile / Spare Parts / Ricambi

Trägerwerkzeug Holder Utensile	Schraube Screw Vite	Schlüssel Key Chiave
11616..-12020..-12525..-M	T154	KS 1111
12025..-12525..-13232..	T205	T5120
313232L/R	T206	T5120

Radial-Stechdrehen gerade / Radial groove turning straight / Utensile dritto - Scanalatura e copiatura radiale

Für Langdrehautomaten / For sliding head auto lathes / Per fantina mobile

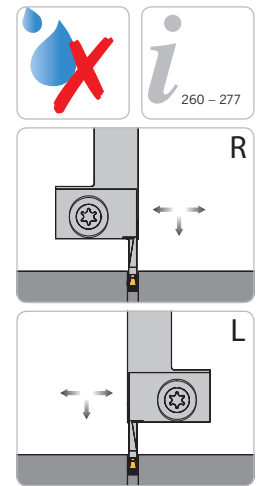
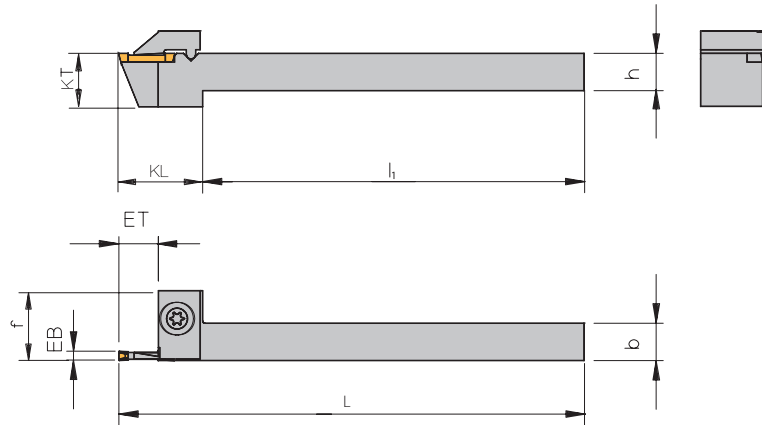

Rechte Ausführung abgebildet
 Right-hand execution shown
 Versione destra in figura

Trägerwerkzeuge / Holders / Utensili

Bezeichnung Designation Articolo	h	b	L	l ₁	f	PG 12
70808-2L/R	8	8	100	82	15	●
70808-3L/R	8	8	100	82	15	●
71010-2L/R	10	10	100	82	15	●
71010-3L/R	10	10	100	82	15	●
71212-2L/R	12	12	100	82	15	●
71212-3L/R	12	12	100	82	15	●
71616-2L/R	16	16	100	82	16	●
71616-3L/R	16	16	100	82	16	●

Grundhalter und Zubehör / Basic holder and accessories / Corpo utensile e accessori

Grundhalter Basic holder Corpo utensile	EB	ET	KL	KT	Klemme Clamp Staffa	Schneideinsatz Insert Inserto	Schraube Screw Vite	Schlüssel Key Chiave
70808-2L/R	2	8	18	12	KAM2 R/L	212...	T 154	KS 1111
71010-2L/R	2	8	18	12	KAM2 R/L	212...	T 154	KS 1111
71212-2L/R	2	8	18	12	KAM2 R/L	212...	T 154	KS 1111
71616-2L/R	2	8	18	16	KAM2 R/L	212...	T 154	KS 1111
70808-3L/R	3	8	18	12	KAML3 R/L	316...	T 154	KS 1111
71010-3L/R	3	8	18	12	KAML3 R/L	316...	T 154	KS 1111
71212-3L/R	3	8	18	12	KAML3 R/L	316...	T 154	KS 1111
71616-3L/R	3	8	18	16	KAML3 R/L	316...	T 154	KS 1111

Grundhalter werden mit Schrauben und Schlüssel geliefert, jedoch ohne U-Platte und Klemme.

Basic holders will be supplied with screws and key, however without support blade and clamp.

Gli steli sono forniti completi di viti e una chiave ma senza staffa e lama.

Hinweis: Grundhalter muss in axialer Richtung an der Werkzeugaufnahme anliegen!

Remark: Basic holder must be adapted in axial direction on to the work holding tool!

Nota: L'utensile base deve essere montato in direzione assiale sull'attacco!

Ersatzteile / Spare Parts / Ricambi

Trägerwerkzeug Holder Utensile	Schraube Screw Vite	Schlüssel Key Chiave
70808-2 ...-71616-3 ..	T154	KS 1111

Stechdrehen – Axial und Radial

Groove turning - axial and radial

Scanalatura e copiatura assiale e radiale

Polygonschaft / Polygon-Shank / Attacco polygonale

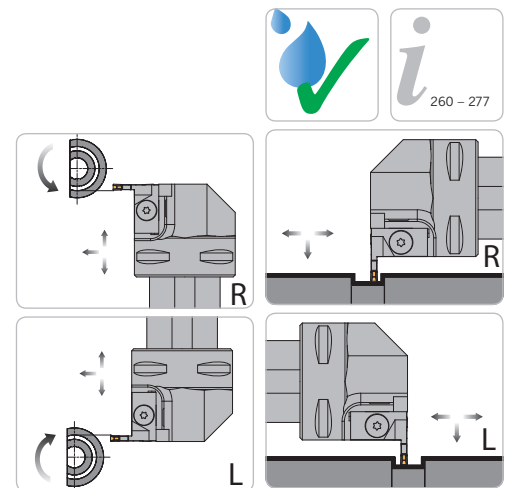
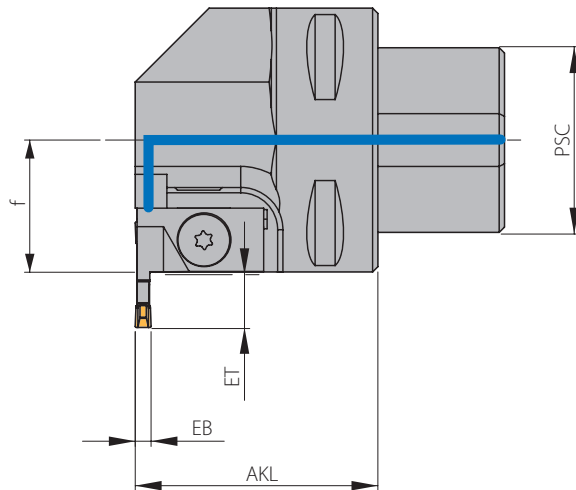

Rechte Ausführung abgebildet
 Right-hand execution shown
 Versione destra in figura

3

Trägerwerkzeuge / Holders / Utensili

Bezeichnung Designation Articolo	EB	H	AKL	f	PSC	PG 43
PSC50-2-3RA-L/R	0,5 - 3,0	25	46	25	PSC50	●
PSC50-3-6RA-L/R*	3,0 - 6,0	25	46	25	PSC50	●
PSC63-3-6RA-L/R*	3,0 - 6,0	32	52	32	PSC60	●
PSC80-3-6RA-L/R*	3,0 - 6,0	41	62	41	PSC80	●

*Bei Stechbreite 6 mm --> Maß „f“ + 0,5 mm

*For width of cut 6 mm --> Dimension „f“ + 0,5 mm

*Per larghezza di taglio di 6 mm --> Dimensione „f“ + 0,5 mm

Bitte beachten: Rechter Halter --> Linkes Zubehör Linker Halter --> Rechtes Zubehör

Please note: Holder right hand-design --> Left-hand spare parts Holder left hand-design --> Right-hand spare parts

Attenzione: portautensile destro --> accessori sinistri portautensile sinistro --> accessori destri

Hinweis: Es passen alle Zubehöreile aus dem Standard-Programm „Axial Stechdrehen - Kontra Ausführung“ und „Axial - Stechdrehen“.

Information: Toolholder is suitable for all spare parts from the standard programme „Axial groove turning - Kontra“ and „Axial groove turning“.

Nota: l'utensile è compatibile con tutti i ricambi del programma standard „Scanalatura assiale esecuzione Kontra“ e „Scanalatura assiale“.

Grundhalter und Zubehör / Basic holder and accessories / Corpo utensile e accessori

Grundhalter Basic holder Corpo utensile	EB	ET	ET ₂	U-Platte Support blade Lama	Klemme Clamp Staffa	Schneideinsatz Insert Inserto
PSC50-2-3RA-L/R	0,5 – 1,85	= EB	= EB	UA2/471 R/L	KAM2 R/L	2-../471 R/L
	0,5 – 3,08	= EB	= EB	UA3/471 R/L	KAM3 R/L	3M-../471 R/L
	2,00	8,0	8,0	10208 R/L	KAM2 R/L	212....
	3,00	12,0	12,0	10312 R/L	KAM3 R/L	316....

Weiteres Zubehör auf der nächsten Seite
 More accessories next page
 Altri accessori nella pagina seguente

Grundhalter und Zubehör / Basic holder and accessories / Corpo utensile e accessori

Grundhalter Basic holder Corpo utensile	EB	ET	ET ₂	U-Platte Support blade Lama	Klemme Clamp Staffa	Schneideinsatz Insert Inserito
PSC50-3-6RA-L/R PSC63-3-6RA-L/R PSC80-3-6RA-L/R	0,5 – 3,08	= EB	= EB	UA471 R/L	KA3 R/L	3-../471 R/L
	3,00	9,5	9,5	20310 R/L	KA3 R/L	320....
	4,00	11,5	11,5	20412 R/L	KA4 R/L	422....
	5,00	14,5	14,5	20515 R/L	KA5 R/L	525....
	6,00	19,5	19,5	20620 R/L	KA6 R/L	630....
	3,00	16,0	18,5	UT316 R/L	KT3 R/L	320....
	4,00	19,0	21,5	UT419 R/L	KT4 R/L	422....
	5,00	22,0	24,5	UT522 R/L	KT5 R/L	525....
	6,00	27,0	29,5	UT627 R/L	KT6 R/L	630....

ET₂ = Stechtiefe kann auf Maß „ET₂“ erhöht werden.

ET₂ = Grooving depth can be increased to measure "ET₂".

ET₂ = La profondità di scanalatura può essere aumentata alla dimensione "ET₂".

Grundhalter werden mit Schrauben und Schlüssel geliefert, jedoch ohne U-Platte und Klemme.

Basic holders will be supplied with screws and key, however without support blade and clamp.

Gli steli sono forniti completi di viti e una chiave ma senza staffa e lama.

Achtung: Schwerverspannklemme für NC-Stechdrehen, bei unterbrochenen Schnitten oder Vibrationen, siehe Seite 212.

Attention: Heavy duty clamp for NC-Groove turning, at interrupted cuts or vibrations, please refer to page 212.

Attenzione: Staffa a serraggio rinforzata, per taglio interrotto o in caso di vibrazioni, vedere pagina 212.

Ersatzteile / Spare Parts / Ricambi

Trägerwerkzeug Holder Utensile	Schraube Screw Vite	Schlüssel Key Chiave	Kühlmitteldüse Coolant jet Ugello refrigerante	Schraube für Kühlmitteldüse Screw for coolant jet Vite per ugello refrigerante
PSC50-2-3..	T154	KS 1111	KMD 0519	AS 0020
PSC50-3-6.. -PSC80-3-6..	T205	T5120	KMD 0818	AS 0020

Radial-Stechdrehen / Radial groove turning / Scanalatura radiale
UTS / KM

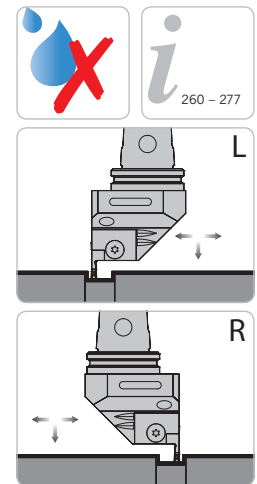
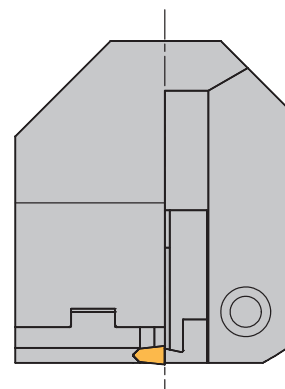
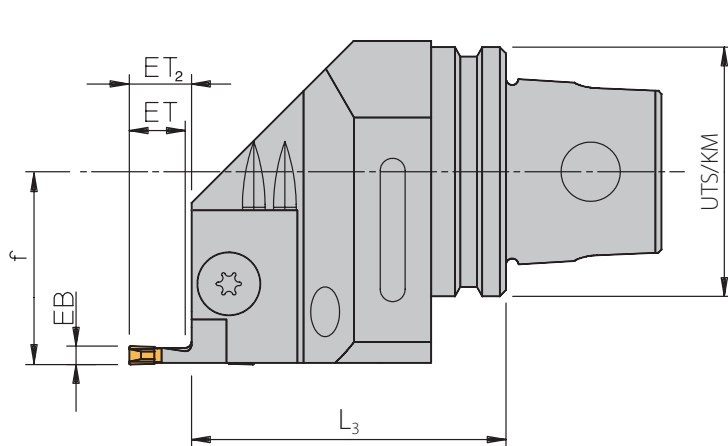

Rechte Ausführung abgebildet
Right-hand execution shown
Versione destra in figura

3

Trägerwerkzeuge / Holders / Utensili

Bezeichnung Designation Articolo	UTS/KM	f	L ₃	PG 43
UT32-2-3L/R	32	25,0	40,0	●
UT32-3-6L*	32	25,0	45,0	●
UT40-3-6L/R	40	31,0	50,5	●
UT50-2-3R*	50	25,0	45,0	●
UT50-3-6L/R*	50	36,0	56,0	●
UT63-3-6L/R*	63	42,0	57,0	●
UT63-8-10R*	63	41,5	67,0	●

*Bei Stechbreite 6 mm --> Maß „f“ + 0,5 mm

*For width of cut 6 mm --> Dimension „f“ + 0,5 mm

*Per larghezza di taglio di 6 mm --> Dimensione „f“ + 0,5 mm

Grundhalter und Zubehör / Basic holder and accessories / Corpo utensile e accessori

Grundhalter Basic holder Corpo utensile	EB	ET	ET ₂	U-Platte Support blade Lama	Klemme Clamp Staffa	Schneideinsatz Insert Inserto
UT32-2-3L/R UT50-2-3R	0,5 – 1,85	= EB	= EB	UA2/471 R/L	KAM2 R/L	2-../471 R/L
	0,5 – 3,08	= EB	= EB	UA3/471 R/L	KAM3 R/L	3M-../471 R/L
	2,00	8,0	8,0	10208 R/L	KAM2 R/L	212....
	3,00	12,0	12,0	10312 R/L	KAM3 R/L	316....
UT32-3-6L/R UT40-3-6L/R UT50-3-6L/R UT63-3-6L/R	0,5 – 3,08	= EB	= EB	UA471 R/L	KA3 R/L	3-../471 R/L
	3,00	9,5	9,5	20310 R/L	KA3 R/L	320....
	4,00	11,5	11,5	20412 R/L	KA4 R/L	422....
	5,00	14,5	14,5	20515 R/L	KA5 R/L	525....
	6,00	19,5	19,5	20620 R/L	KA6 R/L	630....
	3,00	16,0	18,5	UT316 R/L	KT3 R/L	320....
	4,00	19,0	21,5	UT419 R/L	KT4 R/L	422....
	5,00	22,0	24,5	UT522 R/L	KT5 R/L	525....
6,00	27,0	29,5	UT627 R/L	KT6 R/L	630....	

Weiteres Zubehör auf der nächsten Seite
More accessories next page
Altri accessori nella pagina seguente

Grundhalter und Zubehör / Basic holder and accessories / Corpo utensile e accessori

Grundhalter Basic holder Corpo utensile	EB	ET	ET ₂	U-Platte Support blade Lama	Klemme Clamp Staffa	Schneideinsatz Insert Inserito
UT63-8-10R	8,00	18,0	18,0	30817 R/L	KAK8 R/L	838....
	10,00	26,0	26,0	31025 R/L	KAK10 R/L	1046....
	8,00	32,5	32,5	UT 832 R/L	KA8 R/L	838....
	10,00	40,5	40,5	UT 1040 R/L	KA10 R/L	1046....

ET₂ = Stechtiefe kann auf Maß „ET₂“ erhöht werden.

ET₂ = Grooving depth can be increased to measure "ET₂".

ET₂ = La profondità di scanalatura può essere aumentata alla dimensione "ET₂".

Grundhalter werden mit Schrauben und Schlüssel geliefert, jedoch ohne U-Platte und Klemme.

Basic holders will be supplied with screws and key, however without support blade and clamp.

Gli steli sono forniti completi di viti e una chiave ma senza staffa e lama.

Achtung: Schwerspannklemme für NC-Stechdrehen, bei unterbrochenen Schnitten oder Vibrationen, siehe Seite 212.

Attention: Heavy duty clamp for NC-Groove turning, at interrupted cuts or vibrations, please refer to page 212.

Attenzione: Staffa a serraggio rinforzata, per taglio interrotto o in caso di vibrazioni, vedere pagina 212.

Ersatzteile / Spare Parts / Ricambi

Trägerwerkzeug Holder Utensile	Schraube Screw Vite	Schlüssel Key Chiave
UT32-2-3.. -UT50-2-3R	T154	KS 1111
UT32-3-6.. -UT63-3-6..	T205	T5120
UT63-8-10R	T206	T5120

3

Radial-Stechdrehen / Radial groove turning / Scanalatura radiale

VDI

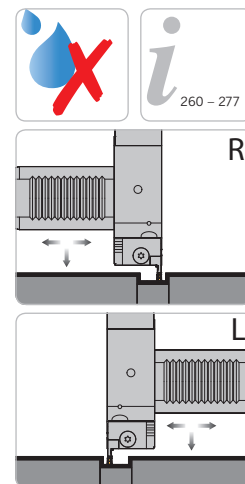
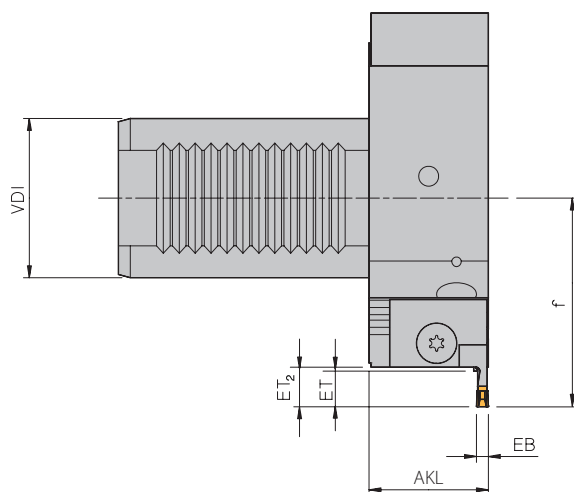

Rechte Ausführung abgebildet
 Right-hand execution shown
 Versione destra in figura

3

Trägerwerkzeuge / Holders / Utensili

Bezeichnung Designation Articolo	VDI	AKL	f	PG 12
VDI30RA-L/R7	30	30	35,0	●
VDI40RA-L/R3*	40	30	45,0	●
VDI40RA-L/R7	40	30	42,5	●
VDI50RA-L/R3*	50	30	50,0	●
VDI50RA-L/R7	50	30	45,0	●
VDI60RA-L/R3*	60	40	55,0	●
VDI60RA-L/R7	60	40	52,5	●

*Bei Stechbreite 6 mm --> Maß „AKL“ + 0,5mm

*For width of cut 6 mm --> Dimension „AKL“ + 0,5mm

*Per larghezza di taglio di 6 mm --> Dimensione „AKL“ + 0,5 mm

Grundhalter und Zubehör / Basic holder and accessories / Corpo utensile e accessori

Grundhalter Basic holder Corpo utensile	EB	ET	ET ₂	U-Platte Support blade Lama	Klemme Clamp Staffa	Schneideinsatz Insert Inserto
VDI30RA-L/R7 VDI40RA-L/R7 VDI50RA-L/R7 VDI60RA-L/R7	0,5 – 3,08	= EB	= EB	UA 471 R/L	KA3 R/L	3-../471 R/L
	3,00	9,5	9,5	20310 R/L	KA3 R/L	320....
	4,00	11,5	11,5	20412 R/L	KA4 R/L	422....
	5,00	14,5	14,5	20515 R/L	KA5 R/L	525....
	6,00	19,5	19,5	20620 R/L	KA6 R/L	630....
	3,00	16,0	18,5	UT 316 R/L	KT3 R/L	320....
	4,00	19,0	21,5	UT 419 R/L	KT4 R/L	422....
	5,00	22,0	24,5	UT 522 R/L	KT5 R/L	525....
VDI40RA-L/R3 VDI50RA-L/R3 VDI60RA-L/R3	6,00	27,0	29,5	UT 627 R/L	KT6 R/L	630....
	8,00	18,0	18,0	30817 R/L	KAK8 R/L	838....
	10,00	26,0	26,0	31025 R/L	KAK10 R/L	1046....
	8,00	32,5	32,5	UT 832 R/L	KA8 R/L	838....
	10,00	40,5	40,5	UT 1040 R/L	KA10 R/L	1046....

ET₂ = Stechtiefe kann auf Maß „ET₂“ erhöht werden.

ET₂ = Grooving depth can be increased to measure “ET₂”.

ET₂ = La profondità di scanalatura può essere aumentata alla dimensione “ET₂”.

Grundhalter werden mit Schrauben und Schlüssel geliefert, jedoch ohne U-Platte und Klemme.

Basic holders will be supplied with screws and key, however without support blade and clamp.

Gli steli sono forniti completi di viti e una chiave ma senza staffa e lama.

Achtung: Schwerverspannklemme für NC-Stechdrehen, bei unterbrochenen Schnitten oder Vibrationen, siehe Seite 212.

Attention: Heavy duty clamp for NC-Groove turning, at interrupted cuts or vibrations, please refer to page 212.

Attenzione: Staffa a serraggio rinforzata, per taglio interrotto o in caso di vibrazioni, vedere pagina 212.

Ersatzteile / Spare Parts / Ricambi

Trägerwerkzeug Holder Utensile	Schraube Screw Vite	Schlüssel Key Chiave
VDI... 3	T206	T5120
VDI... 7	T205	T5120

Schwerspannklemme

Heavy duty clamp

Staffa di serraggio rinforzata

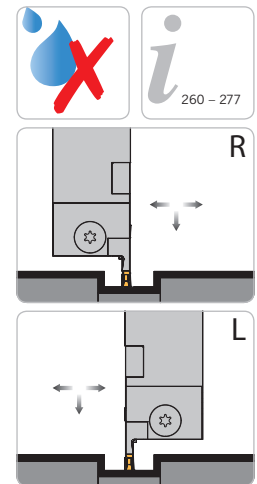
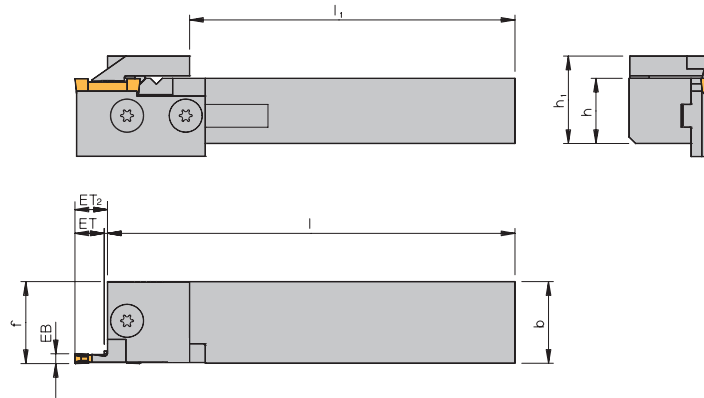

Rechte Ausführung abgebildet
 Right-hand execution shown
 Versione destra in figura

NEU/NEW/NUOVO

Trägerwerkzeuge / Holders / Utensili

Bezeichnung Designation Articolo	h	b	l	h ₁	l ₁	f	PG 12
72025L/R*	20	25	125	27	108	25	●
72525L/R*	25	25	150	32	133	25	●
73225L/R*	32	25	170	39	153	25	●
373225L/R	32	25	170	41	145	26	●
373232L/R	32	32	170	40	145	33	●

*Bei Stechbreite 6 mm --> f = b + 0,5; übrige Stechbreiten f = b
 *For width of cut 6 mm --> f = b + 0.5; for all others f = b
 *Per larghezza di taglio di 6 mm --> f = b + 0,5; altre larghezze f = b

Grundhalter und Zubehör / Basic holder and accessories / Corpo utensile e accessori

Grundhalter Basic holder Corpo utensile	EB	ET	ET ₂	U-Platte Support blade Lama	Klemme Clamp Staffa	Schneideinsatz Insert Inserto
72025L/R 72525L/R 73225L/R	3,00	9,5	9,5	20310 R/L	KAS3 R/L	320....
	4,00	11,5	11,5	20412 R/L	KAS4 R/L	422....
	5,00	14,5	14,5	20515 R/L	KAS5 R/L	525....
	6,00	19,5	19,5	20620 R/L	KAS6 R/L	630....
	3,00	16,0	18,5	UT 316 R/L	KTS3 R/L	320....
	4,00	19,0	21,5	UT 419 R/L	KTS4 R/L	422....
	5,00	22,0	24,5	UT 522 R/L	KTS5 R/L	525....
373232L/R	8,00	18,0	18,0	30817 R/L	KAS8 R/L	838....
	10,00	26,0	26,0	31025 R/L	KAS10 R/L	1046....
	8,00	32,5	32,5	UT 832 R/L	KTS8 R/L	838....
	10,00	40,5	40,5	UT 1040 R/L	KTS10 R/L	1046....

ET₂ = Stechtiefe kann auf Maß „ET₂“ erhöht werden.
 ET₂ = Grooving depth can be increased to measure "ET₂".
 ET₂ = La profondità di scanalatura può essere aumentata alla dimensione "ET₂".

Grundhalter werden mit Schrauben und Schlüssel geliefert, jedoch ohne U-Platte und Klemme.
 Basic holders will be supplied with screws and key, however without support blade and clamp.
 Gli steli sono forniti completi di viti e una chiave ma senza staffa e lama.

Achtung: Schwerverspannklemme kann nur bei Grundhaltern mit zweiter Nut auf der Spannfläche eingesetzt werden.
 Attention: Heavy duty clamp can only be used with basic holders with two grooves.
 Attenzione: Staffa di serraggio rinforzata può solo essere utilizzata su un corpo utensile a due scanalature.

Ersatzteile / Spare Parts / Ricambi

Trägerwerkzeug Holder Utensile	Schraube Screw Vite	Schlüssel Key Chiave
373225.. -373232..	T206	T5120
72025.. -73225..	T205	T5120

Stechdrehen – 45°

Groove turning - 45°

Scanalatura e copatura - 45°

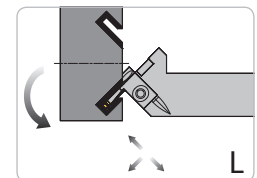
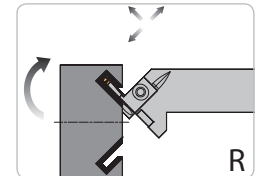
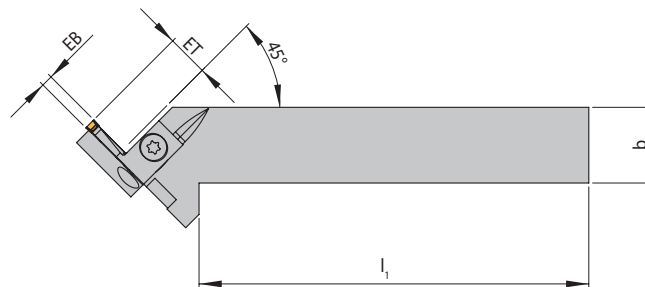
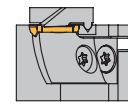

Rechte Ausführung abgebildet
 Right-hand execution shown
 Versione destra in figura

Trägerwerkzeuge / Holders / Utensili

Bezeichnung Designation Articolo	h	b	l ₁	PG 12
452020L/R	20	20	103	●

Grundhalter und Zubehör / Basic holder and accessories / Corpo utensile e accessori

Grundhalter Basic holder Corpo utensile	EB	ET	U-Platte Support blade Lama	Klemme Clamp Staffa	Schneideinsatz Insert Inserto
452020L/R	2	8	102... R/L	KAM2 R/L	212....
	3	12	103... R/L	KAM3 R/L	316....

Hinweis: Es passen alle Zubehörteile aus dem Standard-Programm „Axial-Stechdrehen“ Seite 217.

Achtung: Unterstützplatten immer die nächstgrößere Ausführung bezogen auf den Nut-Außendurchmesser (DA) wählen
 z. B.: EB = 3 mm, ET = 12 mm, DA = 67 mm, rechts wählen Sie: 103 - 75100R

Remark: Toolholders are suitable for all spare parts from the standard programme "Axial groove turning" page 217.

Attention: Please select always the next larger range of diameter referring to your OD of groove (DA)
 e.g. EB = 3 mm, ET = 12 mm, DA = 67 mm, on the right select: 103 - 75100R

Nota: L'utensile standard può montare tutti gli accessori del programma "Scanalatura Assiale" pagina 217.

Attenzione: Scegliere sempre la misura del diametro successiva riferita al vostro diam. di scanalatura (DA)
 p. es. EB = 3 mm, ET = 12 mm, DA = 67 mm, scelta corretta: 103 - 75100R

Ersatzteile / Spare Parts / Ricambi

Trägerwerkzeug Holder Utensile	Schraube Screw Vite	Schlüssel Key Chiave
452020L/R	T154	KS 1111

Stechdrehen – 45°

Groove turning - 45°

Scanalatura e copertura - 45°

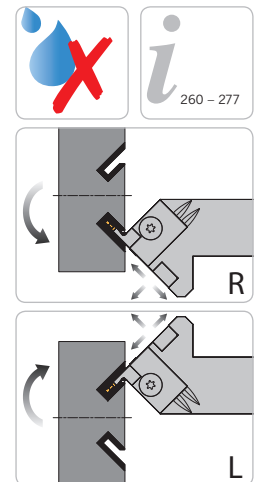
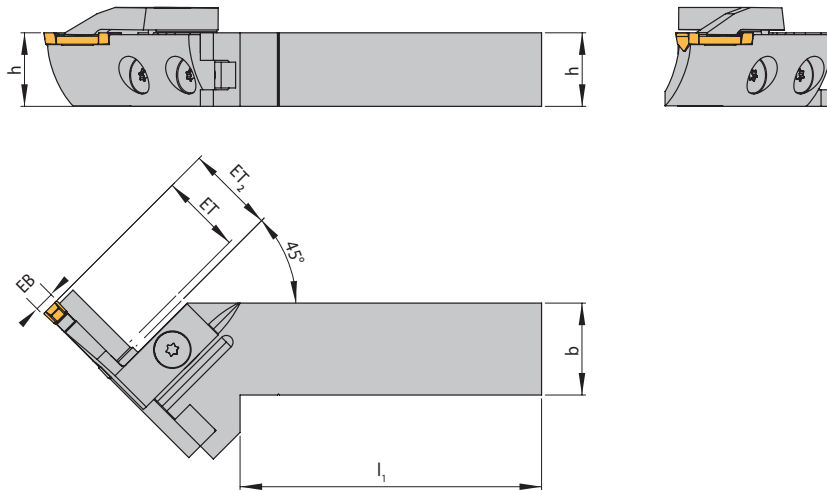

Rechte Ausführung abgebildet
 Right-hand execution shown
 Versione destra in figura

3

Trägerwerkzeuge / Holders / Utensili

Bezeichnung Designation Articolo	h	b	l ₁	PG 12
452025L/R	20	25	82	●
452525L/R	25	25	82	●

Grundhalter und Zubehör / Basic holder and accessories / Corpo utensile e accessori

Grundhalter Basic holder Corpo utensile	EB	ET	ET ₂	U-Platte Support blade Lama	Klemme Clamp Staffa	Schneideinsatz Insert Inserto
452025L/R 452525L/R	3	9,5	9,5	203... R/L	KA3 R/L	320...
	3	16,0	18,5	UT3... R/L	KT3 R/L	320...
	4	11,5	11,5	204... R/L	KA4 R/L	422...
	4	19,0	21,5	UT4... R/L	KT4 R/L	422...
	5	14,5	14,5	205... R/L	KA5 R/L	525...
	5	22,0	24,5	UT5... R/L	KT5 R/L	525...
	6	19,5	19,5	206... R/L	KA6 R/L	630...
6	27,0	29,5	UT6... R/L	KT6 R/L	630...	

ET₂ = Stechtiefe kann auf Maß „ET₂“ erhöht werden.

ET₂ = Grooving depth can be increased to measure "ET₂".

ET₂ = La profondità di scanalatura può essere aumentata alla dimensione "ET₂".

Hinweis: Es passen alle Zubehörteile aus dem Standard-Programm „Axial-Stechdrehen“ Seite 217.

Achtung: Unterstützplatten immer die nächstgrößere Ausführung bezogen auf den Nut-Außendurchmesser (DA) wählen
 z. B.: EB = 3 mm, ET = 12 mm, DA = 67 mm, rechts wählen Sie: 103 - 75100R

Remark: Toolholders are suitable for all spare parts from the standard programme "Axial groove turning" page 217.

Attention: Please select always the next larger range of diameter referring to your OD of groove (DA)
 e.g. EB = 3 mm, ET = 12 mm, DA = 67 mm, on the right select: 103 - 75100R

Nota: L'utensile standard può montare tutti gli accessori del programma "Scanalatura Assiale" pagina 217.

Attenzione: Scegliere sempre la misura del diametro successiva riferita al vostro diam. di scanalatura (DA)
 p.es. EB = 3 mm, ET = 12 mm, DA = 67 mm, scelta corretta: 103 - 75100R

Ersatzteile / Spare Parts / Ricambi

Trägerwerkzeug Holder Utensile	Schraube Screw Vite	Schlüssel Key Chiave
452025 .. - 452525 ..	T205	T5120

Axial-Stechedrehen gerade – Ø 15 - 25 mm

Axial groove turning straight - Ø 15 - 25 mm

Utensile dritto - Scanalatura e copiatura assiale - Ø 15 - 25mm

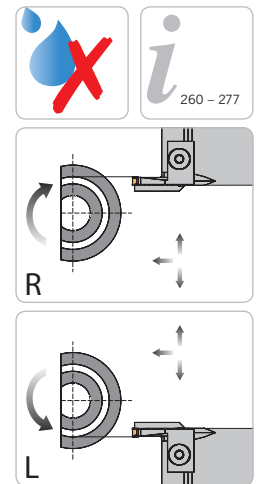
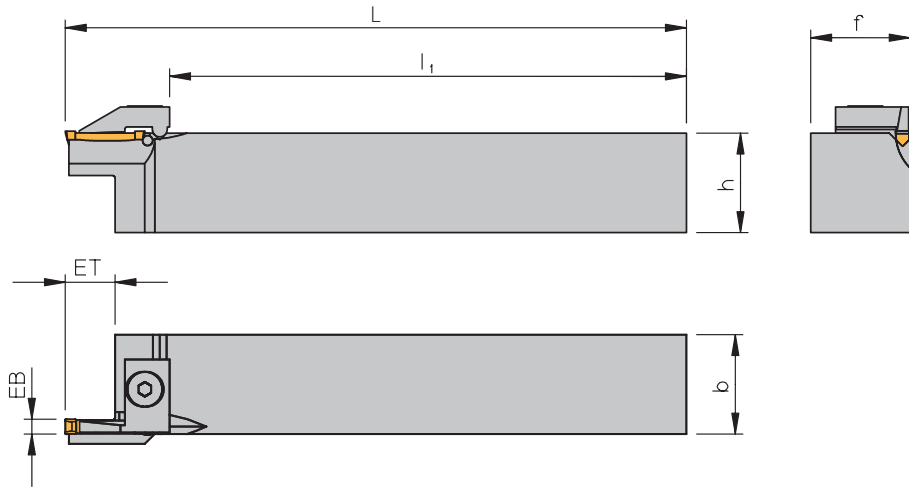

Rechte Ausführung abgebildet
Right-hand execution shown
Versione destra in figura

3

Trägerwerkzeuge / Holders / Utensili

Bezeichnung Designation Articolo	Nut-Au- Ben-Ø OD of groove Ø est. di gola	EB	ET	h	b	L	l ₁	f	PG 12	Klemme Clamp Staffa	Schneideinsatz Insert Inserto
71216-2-1520L/R	15-20	2	6	12	16	90	73	16	●	KAM2L/R	212...
71216-2-2025L/R	20-25	2	6	12	16	90	73	16	●	KAM2L/R	212...
71216-3-1520L/R	15-20	3	9	12	16	90	69	16	●	KAM3L/R	316...
71216-3-2025L/R	20-25	3	9	12	16	90	69	16	●	KAM3L/R	316...
71616-2-1520L/R	15-20	2	6	16	16	110	93	16	●	KAM2L/R	212...
71616-2-2025L/R	20-25	2	6	16	16	110	93	16	●	KAM2L/R	212...
71616-3-1520L/R	15-20	3	9	16	16	110	89	16	●	KAM3L/R	316...
71616-3-2025L/R	20-25	3	9	16	16	110	89	16	●	KAM3L/R	316...
72020-2-1520L/R	15-20	2	6	20	20	125	108	20	●	KAM2L/R	212...
72020-2-2025L/R	20-25	2	6	20	20	125	108	20	●	KAM2L/R	212...
72020-3-1520L/R	15-20	3	9	20	20	125	104	20	●	KAM3L/R	316...
72020-3-2025L/R	20-25	3	9	20	20	125	104	20	●	KAM3L/R	316...

Grundhalter werden mit Schrauben und Schlüssel geliefert, jedoch ohne U-Platte und Klemme.

Holders will be supplied with screws and key, however without support blade and clamp.

I portautensili sono consegnati muniti di viti e di una chiave ma senza lama e staffa.

Achtung: Diese Werkzeuge nur nach der Schafthöhe (Maß „h“) ausrichten, da die Schneidkante über der Drehmitte liegt!

Attention: These tools should be set up according to dimension „h“ (shank-height), because the cutting edge is above centre height!

Attenzione: Questi utensili devono essere montati secondo l'altezza „h“ del gambo, perchè il tagliente è sopra l'altezza del centro!

Ersatzteile / Spare Parts / Ricambi

Trägerwerkzeug Holder Utensile	Schraube Screw Vite	Schlüssel Key Chiave
71216-2.. -72020-36..L/R	T154	KS 1111

Axial-Stechedrehen abgesetzt – Ø 15 - 25 mm

Axial groove turning cranked - Ø 15 - 25 mm

Utensile inclinato - Scanalatura e copiatura assiale - Ø 15 - 25 mm

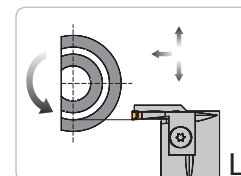
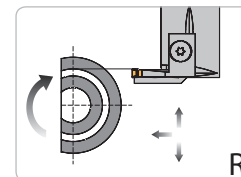
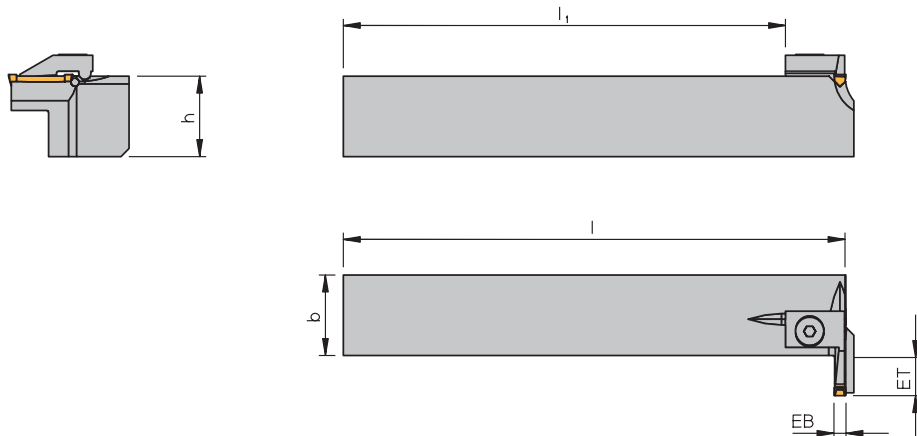

Rechte Ausführung abgebildet
 Right-hand execution shown
 Versione destra in figura

3

Trägerwerkzeuge / Holders / Utensili

Bezeichnung Designation Articolo	Nut-Außen-Ø OD of groove Ø est. di gola	EB	ET	h	b	l	l ₁	PG 12	Klemme Clamp Staffa	Schneideinsatz Insert Inserto
11616-2-1520L/R	15-20	2	6	16	16	110	93	●	KAM2L/R	212...
11616-2-2025L/R	20-25	2	6	16	16	110	93	●	KAM2L/R	212...
11616-3-1520L/R	15-20	3	9	16	16	110	93	●	KAM3L/R	316...
11616-3-2025L/R	20-25	3	9	16	16	110	93	●	KAM3L/R	316...
12020-2-1520L/R	15-20	2	6	20	20	125	108	●	KAM2L/R	212...
12020-2-2025L/R	20-25	2	6	20	20	125	108	●	KAM2L/R	212...
12020-3-1520L/R	15-20	3	9	20	20	125	108	●	KAM3L/R	316...
12020-3-2025L/R	20-25	3	9	20	20	125	108	●	KAM3L/R	316...

Grundhalter werden mit Schrauben und Schlüssel geliefert, jedoch ohne U-Platte und Klemme.

Holders will be supplied with screws and key, however without support blade and clamp.

I portautensili sono consegnati muniti di viti e di una chiave ma senza lama e staffa.

Achtung: Diese Werkzeuge nur nach der Schafthöhe (Maß „h“) ausrichten, da die Schneidkante über der Drehmitte liegt!

Attention: These tools should be set up according to dimension „h“ (shank-height), because the cuttingedge is above centre height!

Attenzione: Questi utensili devono essere montati secondo l'altezza „h“ del gambo, perchè il tagliente è sopra l'altezza del centro!

Ersatzteile / Spare Parts / Ricambi

Trägerwerkzeug Holder Utensile	Schraube Screw Vite	Schlüssel Key Chiave
11616-2.. -12020-3..L/R	T154	KS 1111

Axial-Steindreher gerade / Axial groove turning straight /
 Utensile dritto - Scanalatura e copiatura assiale

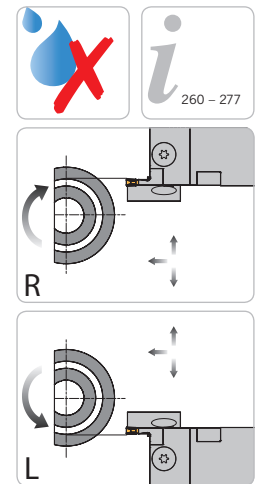
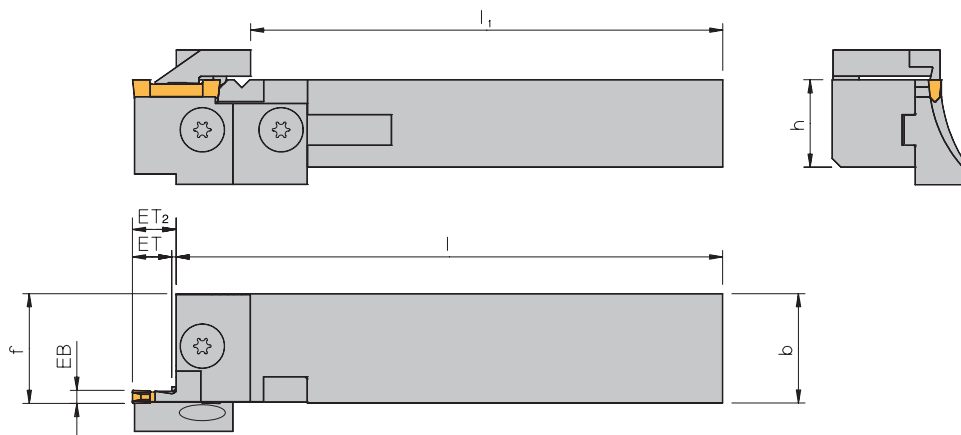

Rechte Ausführung abgebildet
 Right-hand execution shown
 Versione destra in figura

N NEU/NEW/
 NUOVO

Trägerwerkzeuge / Holders / Utensili

Bezeichnung Designation Articolo	h	b	l	l ₁	f	PG 12
71216L/R	12	16	90	81	16	●
71616L/R	16	16	110	101	16	●
72020L/R	20	20	125	116	20	●
72025L/R*	20	25	125	113	25	●
72525L/R*	25	25	150	138	25	●
72525L-M	25	25	150	141	25	●
73225L/R*	32	25	170	158	25	●
373225L/R	32	25	170	145	26	●
373232L/R	32	32	170	145	33	●

*Bei Stechbreite 6 mm --> f = b + 0,5; übrige Stechbreiten f = b

*For width of cut 6 mm --> f = b + 0.5; for all others f = b

*Per larghezza di taglio di 6 mm --> f = b + 0,5; altre larghezze f = b

Grundhalter und Zubehör / Basic holder and accessories / Corpo utensile e accessori

Grundhalter Basic holder Corpo utensile	EB	ET	ET ₂	Nut-Außen-Ø OD of groove Ø est. di gola	U-Platte Support blade Lama	Klemme Clamp Staffa	Schneideinsatz Insert Inserto
71216L/R 71616L/R 72020L/R 72525L/R-M	2	8,0	8,0	25 – 30	102-2530 R/L	KAM2 R/L	212....
	2	8,0	8,0	30 – 40	102-3040 R/L	KAM2 R/L	212....
	2	8,0	8,0	40 – 50	102-4050 R/L	KAM2 R/L	212....
	2	8,0	8,0	50 – 60	102-5060 R/L	KAM2 R/L	212....
	2	8,0	8,0	60 – 75	102-6075 R/L	KAM2 R/L	212....
	2	8,0	8,0	75 – 100	102-75100 R/L	KAM2 R/L	212....
	2	8,0	8,0	100 – 150	102-100150 R/L	KAM2 R/L	212....
	2	8,0	8,0	150 – 300	102-150300 R/L	KAM2 R/L	212....
	2	8,0	8,0	300 – 500	102-300500 R/L	KAM2 R/L	212....
	2	8,0	8,0	500 – ∞	10208 R/L*	KAM2 R/L	212....
	3	12,0	12,0	25 – 30	103-2530 R/L	KAM3 R/L	316....
	3	12,0	12,0	30 – 40	103-3040 R/L	KAM3 R/L	316....
	3	12,0	12,0	40 – 50	103-4050 R/L	KAM3 R/L	316....
	3	12,0	12,0	50 – 60	103-5060 R/L	KAM3 R/L	316....
	3	12,0	12,0	60 – 75	103-6075 R/L	KAM3 R/L	316....
	3	12,0	12,0	75 – 100	103-75100 R/L	KAM3 R/L	316....
	3	12,0	12,0	100 – 150	103-100150 R/L	KAM3 R/L	316....
	3	12,0	12,0	150 – 300	103-150300 R/L	KAM3 R/L	316....
3	12,0	12,0	300 – 500	103-300500 R/L	KAM3 R/L	316....	
3	12,0	12,0	500 – ∞	10312 R/L*	KAM3 R/L	316....	

*Nacharbeit für Durchmesserbereich erforderlich!

*Minimum retouching work required!

*Potrebbe essere necessaria leggera modifica!

Weiteres Zubehör auf der nächsten Seite
 More accessories next page
 Altri accessori nella pagina seguente

Grundhalter und Zubehör / Basic holder and accessories / Corpo utensile e accessori

Grundhalter Basic holder Corpo utensile	EB	ET	ET ₂	Nut-Außen-Ø OD of groove Ø est. di gola	U-Platte Support blade Lama	Klemme Clamp Staffa	Schneideinsatz Insert Inserto
72025L/R 72525L/R 73225L/R	3	9,5	9,5	50 – 60	203-5060 R/L	KA3 R/L	320....
	3	9,5	9,5	60 – 75	203-6075 R/L	KA3 R/L	320....
	3	9,5	9,5	75 – 100	203-75100 R/L	KA3 R/L	320....
	3	9,5	9,5	100 – 150	203-100150 R/L	KA3 R/L	320....
	3	9,5	9,5	150 – 300	203-150300 R/L	KA3 R/L	320....
	3	9,5	9,5	300 – 500	203-300500 R/L	KA3 R/L	320....
	3	9,5	9,5	500 – ∞	203-500XX R/L	KA3 R/L	320....
	3	16,0	18,5	50 – 60	UT3-5060 R/L	KT3 R/L	320....
	3	16,0	18,5	60 – 75	UT3-6075 R/L	KT3 R/L	320....
	3	16,0	18,5	75 – 100	UT3-75100 R/L	KT3 R/L	320....
	3	16,0	18,5	100 – 150	UT3-100150 R/L	KT3 R/L	320....
	3	16,0	18,5	150 – 300	UT3-150300 R/L	KT3 R/L	320....
	3	16,0	18,5	300 – 500	UT3-300500 R/L	KT3 R/L	320....
	3	16,0	18,5	500 – ∞	UT3-500XX R/L	KT3 R/L	320....
	4	11,5	11,5	50 – 60	204-5060 R/L	KA4 R/L	422....
	4	11,5	11,5	60 – 75	204-6075 R/L	KA4 R/L	422....
	4	11,5	11,5	75 – 100	204-75100 R/L	KA4 R/L	422....
	4	11,5	11,5	100 – 150	204-100150 R/L	KA4 R/L	422....
	4	11,5	11,5	150 – 300	204-150300 R/L	KA4 R/L	422....
	4	11,5	11,5	300 – 500	204-300500 R/L	KA4 R/L	422....
	4	11,5	11,5	500 – ∞	204-500XX R/L	KA4 R/L	422....
	4	19,0	21,5	50 – 60	UT4-5060 R/L	KT4 R/L	422....
	4	19,0	21,5	60 – 75	UT4-6075 R/L	KT4 R/L	422....
	4	19,0	21,5	75 – 100	UT4-75100 R/L	KT4 R/L	422....
	4	19,0	21,5	100 – 150	UT4-100150 R/L	KT4 R/L	422....
	4	19,0	21,5	150 – 300	UT4-150300 R/L	KT4 R/L	422....
	4	19,0	21,5	300 – 500	UT4-300500 R/L	KT4 R/L	422....
	4	19,0	21,5	500 – ∞	UT4-500XX R/L	KT4 R/L	422....
	5	14,5	14,5	50 – 60	205-5060 R/L	KA5 R/L	525....
	5	14,5	14,5	60 – 75	205-6075 R/L	KA5 R/L	525....
	5	14,5	14,5	75 – 100	205-75100 R/L	KA5 R/L	525....
	5	14,5	14,5	100 – 150	205-100150 R/L	KA5 R/L	525....
	5	14,5	14,5	150 – 300	205-150300 R/L	KA5 R/L	525....
	5	14,5	14,5	300 – 500	205-300500 R/L	KA5 R/L	525....
	5	14,5	14,5	500 – ∞	205-500XX R/L	KA5 R/L	525....
	5	22,0	24,5	50 – 60	UT5-5060 R/L	KT5 R/L	525....
	5	22,0	24,5	60 – 75	UT5-6075 R/L	KT5 R/L	525....
	5	22,0	24,5	75 – 100	UT5-75100 R/L	KT5 R/L	525....
	5	22,0	24,5	100 – 150	UT5-100150 R/L	KT5 R/L	525....
	5	22,0	24,5	150 – 300	UT5-150300 R/L	KT5 R/L	525....
	5	22,0	24,5	300 – 500	UT5-300500 R/L	KT5 R/L	525....
	5	22,0	24,5	500 – ∞	UT5-500XX R/L	KT5 R/L	525....
6	19,5	19,5	50 – 60	206-5060 R/L	KA6 R/L	630....	
6	19,5	19,5	60 – 75	206-6075 R/L	KA6 R/L	630....	
6	19,5	19,5	75 – 100	206-75100 R/L	KA6 R/L	630....	
6	19,5	19,5	100 – 150	206-100150 R/L	KA6 R/L	630....	
6	19,5	19,5	150 – 300	206-150300 R/L	KA6 R/L	630....	
6	19,5	19,5	300 – 500	206-300500 R/L	KA6 R/L	630....	
6	19,5	19,5	500 – ∞	206-500XX R/L	KA6 R/L	630....	
6	27,0	29,5	50 – 60	UT6-5060 R/L	KT6 R/L	630....	
6	27,0	29,5	60 – 75	UT6-6075 R/L	KT6 R/L	630....	
6	27,0	29,5	75 – 100	UT6-75100 R/L	KT6 R/L	630....	
6	27,0	29,5	100 – 150	UT6-100150 R/L	KT6 R/L	630....	
6	27,0	29,5	150 – 300	UT6-150300 R/L	KT6 R/L	630....	
6	27,0	29,5	300 – 500	UT6-300500 R/L	KT6 R/L	630....	
6	27,0	29,5	500 – ∞	UT6-500XX R/L	KT6 R/L	630....	

Weiteres Zubehör auf der nächsten Seite
More accessories next page
Altri accessori nella pagina seguente

Grundhalter und Zubehör / Basic holder and accessories / Corpo utensile e accessori

Grundhalter Basic holder Corpo utensile	EB	ET	ET ₂	Nut-Außen-Ø OD of groove Ø est. di gola	U-Platte Support blade Lama	Klemme Clamp Staffa	Schneideinsatz Insert Inserto
373225L/R 373232L/R	8	17,0	18,0	75 – 100	308-75100 R/L	KAK8 R/L	838....
	8	17,0	18,0	100 – 150	308-100150 R/L	KAK8 R/L	838....
	8	17,0	18,0	150 – 300	308-150300 R/L	KAK8 R/L	838....
	8	17,0	18,0	300 – 500	308-300500 R/L	KAK8 R/L	838....
	8	17,0	18,0	500 – ∞	308-500XX R/L	KAK8 R/L	838....
	8	32,0	32,5	75 – 100	UT8-75100 R/L	KA8 R/L	838....
	8	32,0	32,5	100 – 150	UT8-100150 R/L	KA8 R/L	838....
	8	32,0	32,5	150 – 300	UT8-150300 R/L	KA8 R/L	838....
	8	32,0	32,5	300 – 500	UT8-300500 R/L	KA8 R/L	838....
	8	32,0	32,5	500 – ∞	UT8-500XX R/L	KA8 R/L	838....
	10	25,0	26,0	75 – 100	310-75100 R/L	KAK10 R/L	1046....
	10	25,0	26,0	100 – 150	310-100150 R/L	KAK10 R/L	1046....
	10	25,0	26,0	150 – 300	310-150300 R/L	KAK10 R/L	1046....
	10	25,0	26,0	300 – 500	310-300500 R/L	KAK10 R/L	1046....
	10	25,0	26,0	500 – ∞	310-500XX R/L	KAK10 R/L	1046....
	10	40,0	40,5	75 – 100	UT10-75100 R/L	KA10 R/L	1046....
	10	40,0	40,5	100 – 150	UT10-100150 R/L	KA10 R/L	1046....
	10	40,0	40,5	150 – 300	UT10-150300 R/L	KA10 R/L	1046....
	10	40,0	40,5	300 – 500	UT10-300500 R/L	KA10 R/L	1046....
	10	40,0	40,5	500 – ∞	UT10-500XX R/L	KA10 R/L	1046....

ET₂ = Stechtiefe kann auf Maß „ET₂“ erhöht werden.

ET₂ = Grooving depth can be increased to measure “ET₂”.

ET₂ = La profondità di scanalatura può essere aumentata alla dimensione “ET₂”.

Grundhalter werden mit Schrauben und Schlüssel geliefert, jedoch ohne U-Platte und Klemme.

Basic holders will be supplied with screws and key, however without support blade and clamp.

Gli steli sono forniti completi di viti e una chiave ma senza staffa e lama.

Achtung: Schwerspannklemme für NC-Stechdrehen, bei unterbrochenen Schnitten oder Vibrationen, siehe Seite 212.

Attention: Heavy duty clamp for NC-Groove turning, at interrupted cuts or vibrations, please refer to page 212.

Attenzione: Staffa a serraggio rinforzata, per taglio interrotto o in caso di vibrazioni, vedere pagina 212.

Ersatzteile / Spare Parts / Ricambi

Trägerwerkzeug Holder Utensile	Schraube Screw Vite	Schlüssel Key Chiave
373225.. -373232..	T206	T5120
71216 ..-72525 ..-M	T154	KS 1111
72025.. -73225..	T205	T5120



Axial-Stechedrehen abgesetzt / Axial groove turning cranked / Utensile inclinato - Scanalatura e copiatura assiale

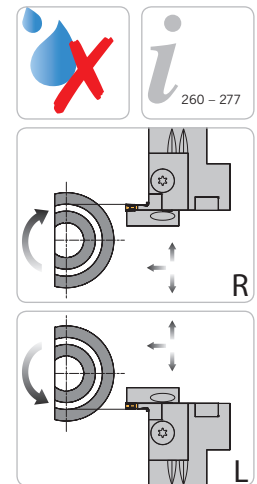
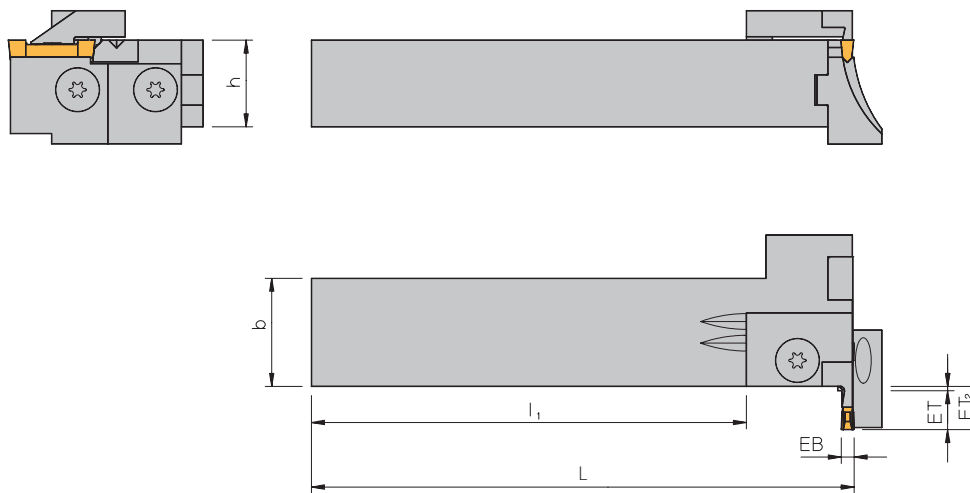

Rechte Ausführung abgebildet
 Right-hand execution shown
 Versione destra in figura

Trägerwerkzeuge / Holders / Utensili

Bezeichnung Designation Articolo	h	b	L	I ₁	PG 12
11616L/R	16	16	110	95	●
12020L/R	20	20	125	110	●
12525L-M	25	25	150	125	●
12025L/R	20	25	125	101	●
12525L/R	25	25	150	126	●
13232L/R	32	32	170	146	●
313232L/R	32	32	170	145	●

Grundhalter und Zubehör / Basic holder and accessories / Corpo utensile e accessori

Grundhalter Basic holder Corpo utensile	EB	ET	ET ₂	Nut-Außen-Ø OD of groove Ø est. di gola	U-Platte Support blade Lama	Klemme Clamp Staffa	Schneideinsatz Insert Inserto
11616L/R 12020L/R 12525L/R-M	2	8,0	8,0	25 – 30	102-2530 R/L	KAM2 R/L	212....
	2	8,0	8,0	30 – 40	102-3040 R/L	KAM2 R/L	212....
	2	8,0	8,0	40 – 50	102-4050 R/L	KAM2 R/L	212....
	2	8,0	8,0	50 – 60	102-5060 R/L	KAM2 R/L	212....
	2	8,0	8,0	60 – 75	102-6075 R/L	KAM2 R/L	212....
	2	8,0	8,0	75 – 100	102-75100 R/L	KAM2 R/L	212....
	2	8,0	8,0	100 – 150	102-100150 R/L	KAM2 R/L	212....
	2	8,0	8,0	150 – 300	102-150300 R/L	KAM2 R/L	212....
	2	8,0	8,0	300 – 500	102-300500 R/L	KAM2 R/L	212....
	2	8,0	8,0	500 – ∞	10208 R/L*	KAM2 R/L	212....
	3	12,0	12,0	25 – 30	103-2530 R/L	KAM3 R/L	316....
	3	12,0	12,0	30 – 40	103-3040 R/L	KAM3 R/L	316....
	3	12,0	12,0	40 – 50	103-4050 R/L	KAM3 R/L	316....
	3	12,0	12,0	50 – 60	103-5060 R/L	KAM3 R/L	316....
	3	12,0	12,0	60 – 75	103-6075 R/L	KAM3 R/L	316....
	3	12,0	12,0	75 – 100	103-75100 R/L	KAM3 R/L	316....
	3	12,0	12,0	100 – 150	103-100150 R/L	KAM3 R/L	316....
	3	12,0	12,0	150 – 300	103-150300 R/L	KAM3 R/L	316....
	3	12,0	12,0	300 – 500	103-300500 R/L	KAM3 R/L	316....
	3	12,0	12,0	500 – ∞	10312 R/L*	KAM3 R/L	316....

*Nacharbeit für Durchmesserbereich erforderlich!

*Minimum retouching work required!

*Potrebbe essere necessaria leggera modifica!

Weiteres Zubehör auf der nächsten Seite
 More accessories next page
 Altri accessori nella pagina seguente

Grundhalter und Zubehör / Basic holder and accessories / Corpo utensile e accessori

Grundhalter Basic holder Corpo utensile	EB	ET	ET ₂	Nut-Außen-Ø OD of groove Ø est. di gola	U-Platte Support blade Lama	Klemme Clamp Staffa	Schneideinsatz Insert Inserto
12025L/R 12525L/R 13232L/R	3	9,5	9,5	50 – 60	203-5060 R/L	KA3 R/L	320....
	3	9,5	9,5	60 – 75	203-6075 R/L	KA3 R/L	320....
	3	9,5	9,5	75 – 100	203-75100 R/L	KA3 R/L	320....
	3	9,5	9,5	100 – 150	203-100150 R/L	KA3 R/L	320....
	3	9,5	9,5	150 – 300	203-150300 R/L	KA3 R/L	320....
	3	9,5	9,5	300 – 500	203-300500 R/L	KA3 R/L	320....
	3	9,5	9,5	500 – ∞	203-500XX R/L	KA3 R/L	320....
	3	16,0	18,5	50 – 60	UT3-5060 R/L	KT3 R/L	320....
	3	16,0	18,5	60 – 75	UT3-6075 R/L	KT3 R/L	320....
	3	16,0	18,5	75 – 100	UT3-75100 R/L	KT3 R/L	320....
	3	16,0	18,5	100 – 150	UT3-100150 R/L	KT3 R/L	320....
	3	16,0	18,5	150 – 300	UT3-150300 R/L	KT3 R/L	320....
	3	16,0	18,5	300 – 500	UT3-300500 R/L	KT3 R/L	320....
	3	16,0	18,5	500 – ∞	UT3-500XX R/L	KT3 R/L	320....
	4	11,5	11,5	50 – 60	204-5060 R/L	KA4 R/L	422....
	4	11,5	11,5	60 – 75	204-6075 R/L	KA4 R/L	422....
	4	11,5	11,5	75 – 100	204-75100 R/L	KA4 R/L	422....
	4	11,5	11,5	100 – 150	204-100150 R/L	KA4 R/L	422....
	4	11,5	11,5	150 – 300	204-150300 R/L	KA4 R/L	422....
	4	11,5	11,5	300 – 500	204-300500 R/L	KA4 R/L	422....
	4	11,5	11,5	500 – ∞	204-500XX R/L	KA4 R/L	422....
	4	19,0	21,5	50 – 60	UT4-5060 R/L	KT4 R/L	422....
	4	19,0	21,5	60 – 75	UT4-6075 R/L	KT4 R/L	422....
	4	19,0	21,5	75 – 100	UT4-75100 R/L	KT4 R/L	422....
	4	19,0	21,5	100 – 150	UT4-100150 R/L	KT4 R/L	422....
	4	19,0	21,5	150 – 300	UT4-150300 R/L	KT4 R/L	422....
	4	19,0	21,5	300 – 500	UT4-300500 R/L	KT4 R/L	422....
	4	19,0	21,5	500 – ∞	UT4-500XX R/L	KT4 R/L	422....
	5	14,5	14,5	50 – 60	205-5060 R/L	KA5 R/L	525....
	5	14,5	14,5	60 – 75	205-6075 R/L	KA5 R/L	525....
	5	14,5	14,5	75 – 100	205-75100 R/L	KA5 R/L	525....
	5	14,5	14,5	100 – 150	205-100150 R/L	KA5 R/L	525....
	5	14,5	14,5	150 – 300	205-150300 R/L	KA5 R/L	525....
	5	14,5	14,5	300 – 500	205-300500 R/L	KA5 R/L	525....
	5	14,5	14,5	500 – ∞	205-500XX R/L	KA5 R/L	525....
	5	22,0	24,5	50 – 60	UT5-5060 R/L	KT5 R/L	525....
	5	22,0	24,5	60 – 75	UT5-6075 R/L	KT5 R/L	525....
	5	22,0	24,5	75 – 100	UT5-75100 R/L	KT5 R/L	525....
	5	22,0	24,5	100 – 150	UT5-100150 R/L	KT5 R/L	525....
	5	22,0	24,5	150 – 300	UT5-150300 R/L	KT5 R/L	525....
	5	22,0	24,5	300 – 500	UT5-300500 R/L	KT5 R/L	525....
	5	22,0	24,5	500 – ∞	UT5-500XX R/L	KT5 R/L	525....
6	19,5	19,5	50 – 60	206-5060 R/L	KA6 R/L	630....	
6	19,5	19,5	60 – 75	206-6075 R/L	KA6 R/L	630....	
6	19,5	19,5	75 – 100	206-75100 R/L	KA6 R/L	630....	
6	19,5	19,5	100 – 150	206-100150 R/L	KA6 R/L	630....	
6	19,5	19,5	150 – 300	206-150300 R/L	KA6 R/L	630....	
6	19,5	19,5	300 – 500	206-300500 R/L	KA6 R/L	630....	
6	19,5	19,5	500 – ∞	206-500XX R/L	KA6 R/L	630....	
6	27,0	29,5	50 – 60	UT6-5060 R/L	KT6 R/L	630....	
6	27,0	29,5	60 – 75	UT6-6075 R/L	KT6 R/L	630....	
6	27,0	29,5	75 – 100	UT6-75100 R/L	KT6 R/L	630....	
6	27,0	29,5	100 – 150	UT6-100150 R/L	KT6 R/L	630....	
6	27,0	29,5	150 – 300	UT6-150300 R/L	KT6 R/L	630....	
6	27,0	29,5	300 – 500	UT6-300500 R/L	KT6 R/L	630....	
6	27,0	29,5	500 – ∞	UT6-500XX R/L	KT6 R/L	630....	



Weiteres Zubehör auf der nächsten Seite
More accessories next page
Altri accessori nella pagina seguente

Grundhalter und Zubehör / Basic holder and accessories / Corpo utensile e accessori

Grundhalter Basic holder Corpo utensile	EB	ET	ET ₂	Nut-Außen-Ø OD of groove Ø est. di gola	U-Platte Support blade Lama	Klemme Clamp Staffa	Schneideinsatz Insert Inserto
313232L/R	8	17,0	18,0	75 – 100	308-75100 R/L	KAK8 R/L	838....
	8	17,0	18,0	100 – 150	308-100150 R/L	KAK8 R/L	838....
	8	17,0	18,0	150 – 300	308-150300 R/L	KAK8 R/L	838....
	8	17,0	18,0	300 – 500	308-300500 R/L	KAK8 R/L	838....
	8	17,0	18,0	500 – ∞	308-500XX R/L	KAK8 R/L	838....
	8	32,0	32,5	75 – 100	UT8-75100 R/L	KA8 R/L	838....
	8	32,0	32,5	100 – 150	UT8-100150 R/L	KA8 R/L	838....
	8	32,0	32,5	150 – 300	UT8-150300 R/L	KA8 R/L	838....
	8	32,0	32,5	300 – 500	UT8-300500 R/L	KA8 R/L	838....
	8	32,0	32,5	500 – ∞	UT8-500XX R/L	KA8 R/L	838....
	10	25,0	26,0	75 – 100	310-75100 R/L	KAK10 R/L	1046....
	10	25,0	26,0	100 – 150	310-100150 R/L	KAK10 R/L	1046....
	10	25,0	26,0	150 – 300	310-150300 R/L	KAK10 R/L	1046....
	10	25,0	26,0	300 – 500	310-300500 R/L	KAK10 R/L	1046....
	10	25,0	26,0	500 – ∞	310-500XX R/L	KAK10 R/L	1046....
	10	40,0	40,5	75 – 100	UT10-75100 R/L	KA10 R/L	1046....
	10	40,0	40,5	100 – 150	UT10-100150 R/L	KA10 R/L	1046....
	10	40,0	40,5	150 – 300	UT10-150300 R/L	KA10 R/L	1046....
	10	40,0	40,5	300 – 500	UT10-300500 R/L	KA10 R/L	1046....
	10	40,0	40,5	500 – ∞	UT10-500XX R/L	KA10 R/L	1046....

ET₂ = Stechtiefe kann auf Maß „ET₂“ erhöht werden.

ET₂ = Grooving depth can be increased to measure "ET₂".

ET₂ = La profondità di scanalatura può essere aumentata alla dimensione "ET₂".

Grundhalter werden mit Schrauben und Schlüssel geliefert, jedoch ohne U-Platte und Klemme.

Basic holders will be supplied with screws and key, however without support blade and clamp.

Gli steli sono forniti completi di viti e una chiave ma senza staffa e lama.

Achtung: Schwerspannklemme für NC-Stechdrehen, bei unterbrochenen Schnitten oder Vibrationen, siehe Seite 212.

Attention: Heavy duty clamp for NC-Groove turning, at interrupted cuts or vibrations, please refer to page 212.

Attenzione: Staffa a serraggio rinforzata, per taglio interrotto o in caso di vibrazioni, vedere pagina 212.

Ersatzteile / Spare Parts / Ricambi

Trägerwerkzeug Holder Utensile	Schraube Screw Vite	Schlüssel Key Chiave
11616L/R - 12525L/R-M	T154	KS 1111
12025L/R - 13232L/R	T205	T5120
313232L/R	T206	T5120

Stechdrehen – Axial und Radial

Groove turning - axial and radial

Scanalatura e copiatura assiale e radiale

Polygonschaft / Polygon-Shank / Attacco polygonale

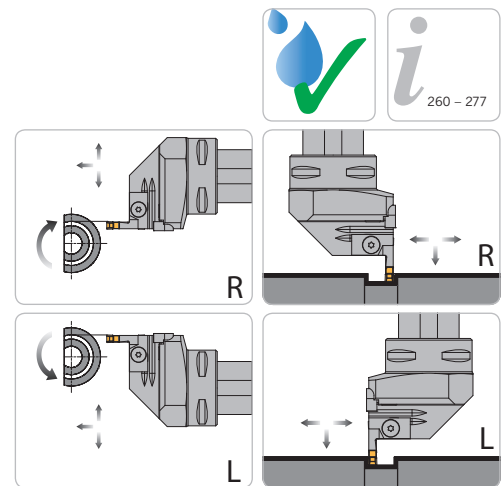
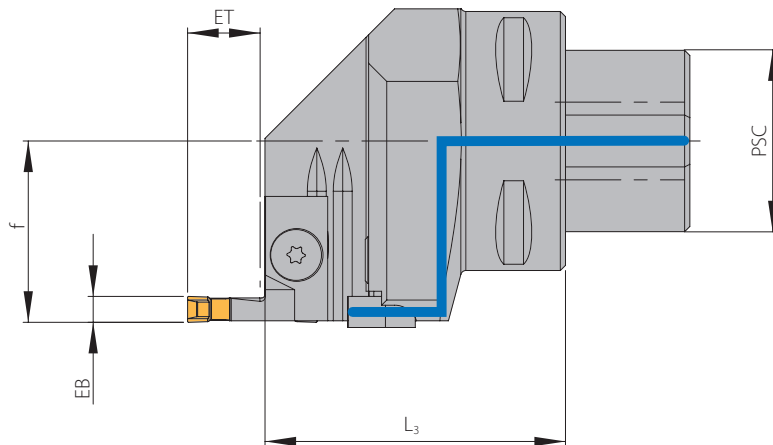

Rechte Ausführung abgebildet
 Right-hand execution shown
 Versione destra in figura

Trägerwerkzeuge / Holders / Utensili

Bezeichnung Designation Articolo	PSC	EB	H	f	L ₃	PG 43
PSC40-2-3L/R	PSC40	2 - 3	20,5	27	45	●
PSC40-3-6L/R*	PSC40	3 - 6	24,0	27	58	●
PSC50-2-3L	PSC50	2 - 3	25,5	35	45	●
PSC50-3-6L/R*	PSC50	3 - 6	25,0	35	58	●
PSC63-2-3L/R	PSC60	2 - 3	32,0	45	60	●
PSC63-3-6L/R*	PSC60	3 - 6	32,0	45	60	●
PSC80-3-6L*	PSC80	3 - 6	40,5	42	80	●

*Bei Stechbreite 6 mm --> Maß „f“ + 0,5 mm

*For width of cut 6 mm --> Dimension „f“ + 0,5 mm

*Per larghezza di taglio di 6 mm --> Dimensione „f“ + 0,5 mm

Grundhalter und Zubehör / Basic holder and accessories / Corpo utensile e accessori

Grundhalter Basic holder Corpo utensile	EB	ET	ET ₂	Nut-Außen-Ø OD of groove Ø est. di gola	U-Platte Support blade Lama	Klemme Clamp Staffa	Schneideinsatz Insert Inserto
PSC40-2-3L/R	2	8,0	8,0	25 – 30	102-2530 R/L	KAM2 R/L	212....
	2	8,0	8,0	30 – 40	102-3040 R/L	KAM2 R/L	212....
	2	8,0	8,0	40 – 50	102-4050 R/L	KAM2 R/L	212....
	2	8,0	8,0	50 – 60	102-5060 R/L	KAM2 R/L	212....
	2	8,0	8,0	60 – 75	102-6075 R/L	KAM2 R/L	212....
	2	8,0	8,0	75 – 100	102-75100 R/L	KAM2 R/L	212....
	2	8,0	8,0	100 – 150	102-100150 R/L	KAM2 R/L	212....
	2	8,0	8,0	150 – 300	102-150300 R/L	KAM2 R/L	212....
	2	8,0	8,0	300 – 500	102-300500 R/L	KAM2 R/L	212....
	2	8,0	8,0	500 – ∞	10208 R/L*	KAM2 R/L	212....
PSC50-2-3L	3	12,0	12,0	25 – 30	103-2530 R/L	KAM3 R/L	316....
	3	12,0	12,0	30 – 40	103-3040 R/L	KAM3 R/L	316....
PSC63-2-3L/R	3	12,0	12,0	40 – 50	103-4050 R/L	KAM3 R/L	316....
	3	12,0	12,0	50 – 60	103-5060 R/L	KAM3 R/L	316....
	3	12,0	12,0	60 – 75	103-6075 R/L	KAM3 R/L	316....
	3	12,0	12,0	75 – 100	103-75100 R/L	KAM3 R/L	316....
	3	12,0	12,0	100 – 150	103-100150 R/L	KAM3 R/L	316....
	3	12,0	12,0	150 – 300	103-150300 R/L	KAM3 R/L	316....
	3	12,0	12,0	300 – 500	103-300500 R/L	KAM3 R/L	316....
	3	12,0	12,0	500 – ∞	10312 R/L*	KAM3 R/L	316....

*Nacharbeit für Durchmesserbereich erforderlich! Achtung: Schwerverspannklemme für NC-Stechdrehen, bei unterbrochenen Schnitten oder Vibrationen, siehe Seite 212.

*Minimum retouching work required!

Attention: Heavy duty clamp for NC-Groove turning, at interrupted cuts or vibrations, please refer to page 212.

*Potrebbe essere necessaria leggera modifica!

Attenzione: Staffa a serraggio rinforzata, per taglio interrotto o in caso di vibrazioni, vedere pagina 212.

Weiteres Zubehör auf der nächsten Seite
 More accessories next page
 Altri accessori nella pagina seguente

Grundhalter und Zubehör / Basic holder and accessories / Corpo utensile e accessori

Grundhalter Basic holder Corpo utensile	EB	ET	ET ₂	Nut-Außen-Ø OD of groove Ø est. di gola	U-Platte Support blade Lama	Klemme Clamp Staffa	Schneideinsatz Insert Inserto
PSC40-3-6L/R PSC50-3-6L/R PSC63-3-6L/R PSC80-3-6L	3	9,5	9,5	50 – 60	203-5060 R/L	KA3 R/L	320....
	3	9,5	9,5	60 – 75	203-6075 R/L	KA3 R/L	320....
	3	9,5	9,5	75 – 100	203-75100 R/L	KA3 R/L	320....
	3	9,5	9,5	100 – 150	203-100150 R/L	KA3 R/L	320....
	3	9,5	9,5	150 – 300	203-150300 R/L	KA3 R/L	320....
	3	9,5	9,5	300 – 500	203-300500 R/L	KA3 R/L	320....
	3	9,5	9,5	500 – ∞	203-500XX R/L	KA3 R/L	320....
	3	16,0	18,5	50 – 60	UT3-5060 R/L	KT3 R/L	320....
	3	16,0	18,5	60 – 75	UT3-6075 R/L	KT3 R/L	320....
	3	16,0	18,5	75 – 100	UT3-75100 R/L	KT3 R/L	320....
	3	16,0	18,5	100 – 150	UT3-100150 R/L	KT3 R/L	320....
	3	16,0	18,5	150 – 300	UT3-150300 R/L	KT3 R/L	320....
	3	16,0	18,5	300 – 500	UT3-300500 R/L	KT3 R/L	320....
	3	16,0	18,5	500 – ∞	UT3-500XX R/L	KT3 R/L	320....
	4	11,5	11,5	50 – 60	204-5060 R/L	KA4 R/L	422....
	4	11,5	11,5	60 – 75	204-6075 R/L	KA4 R/L	422....
	4	11,5	11,5	75 – 100	204-75100 R/L	KA4 R/L	422....
	4	11,5	11,5	100 – 150	204-100150 R/L	KA4 R/L	422....
	4	11,5	11,5	150 – 300	204-150300 R/L	KA4 R/L	422....
	4	11,5	11,5	300 – 500	204-300500 R/L	KA4 R/L	422....
	4	11,5	11,5	500 – ∞	204-500XX R/L	KA4 R/L	422....
	4	19,0	21,5	50 – 60	UT4-5060 R/L	KT4 R/L	422....
	4	19,0	21,5	60 – 75	UT4-6075 R/L	KT4 R/L	422....
	4	19,0	21,5	75 – 100	UT4-75100 R/L	KT4 R/L	422....
	4	19,0	21,5	100 – 150	UT4-100150 R/L	KT4 R/L	422....
	4	19,0	21,5	150 – 300	UT4-150300 R/L	KT4 R/L	422....
	4	19,0	21,5	300 – 500	UT4-300500 R/L	KT4 R/L	422....
	4	19,0	21,5	500 – ∞	UT4-500XX R/L	KT4 R/L	422....
	5	14,5	14,5	50 – 60	205-5060 R/L	KA5 R/L	525....
	5	14,5	14,5	60 – 75	205-6075 R/L	KA5 R/L	525....
	5	14,5	14,5	75 – 100	205-75100 R/L	KA5 R/L	525....
	5	14,5	14,5	100 – 150	205-100150 R/L	KA5 R/L	525....
	5	14,5	14,5	150 – 300	205-150300 R/L	KA5 R/L	525....
	5	14,5	14,5	300 – 500	205-300500 R/L	KA5 R/L	525....
	5	14,5	14,5	500 – ∞	205-500XX R/L	KA5 R/L	525....
	5	22,0	24,5	50 – 60	UT5-5060 R/L	KT5 R/L	525....
	5	22,0	24,5	60 – 75	UT5-6075 R/L	KT5 R/L	525....
	5	22,0	24,5	75 – 100	UT5-75100 R/L	KT5 R/L	525....
	5	22,0	24,5	100 – 150	UT5-100150 R/L	KT5 R/L	525....
	5	22,0	24,5	150 – 300	UT5-150300 R/L	KT5 R/L	525....
	5	22,0	24,5	300 – 500	UT5-300500 R/L	KT5 R/L	525....
	5	22,0	24,5	500 – ∞	UT5-500XX R/L	KT5 R/L	525....
6	19,5	19,5	50 – 60	206-5060 R/L	KA6 R/L	630....	
6	19,5	19,5	60 – 75	206-6075 R/L	KA6 R/L	630....	
6	19,5	19,5	75 – 100	206-75100 R/L	KA6 R/L	630....	
6	19,5	19,5	100 – 150	206-100150 R/L	KA6 R/L	630....	
6	19,5	19,5	150 – 300	206-150300 R/L	KA6 R/L	630....	
6	19,5	19,5	300 – 500	206-300500 R/L	KA6 R/L	630....	
6	19,5	19,5	500 – ∞	206-500XX R/L	KA6 R/L	630....	
6	27,0	29,5	50 – 60	UT6-5060 R/L	KT6 R/L	630....	
6	27,0	29,5	60 – 75	UT6-6075 R/L	KT6 R/L	630....	
6	27,0	29,5	75 – 100	UT6-75100 R/L	KT6 R/L	630....	
6	27,0	29,5	100 – 150	UT6-100150 R/L	KT6 R/L	630....	
6	27,0	29,5	150 – 300	UT6-150300 R/L	KT6 R/L	630....	
6	27,0	29,5	300 – 500	UT6-300500 R/L	KT6 R/L	630....	
6	27,0	29,5	500 – ∞	UT6-500XX R/L	KT6 R/L	630....	

ET₂ = Stechtiefe kann auf Maß „ET₂“ erhöht werden.
ET₂ = Grooving depth can be increased to measure "ET₂".
ET₂ = La profondità di scanalatura può essere aumentata alla dimensione "ET₂".

Grundhalter werden mit Schrauben und Schlüssel geliefert, jedoch ohne U-Platte und Klemme.
Basic holders will be supplied with screws and key, however without support blade and clamp.
Gli steli sono forniti completi di viti e una chiave ma senza staffa e lama.

Weiteres Zubehör auf der nächsten Seite
More accessories next page
Altri accessori nella pagina seguente

Ersatzteile / Spare Parts / Ricambi

Trägerwerkzeug Holder Utensile	Schraube Screw Vite	Schlüssel Key Chiave	Kühlmitteldüse Coolant jet Ugello refrigerante	Schraube für Kühlmitteldüse Screw for coolant jet Vite per ugello refrigerante
PSC40-2-3.. - PSC63-2-3..	T154	KS 1111	KMD 0519	AS 0020
PSC40-3-6..	T205	T5120	KMD 0519	AS 0020
PSC50-3-6.. -PSC80-3-6..	T205	T5120	KMD 0818	AS 0020

Axial-Stechdrehen

Axial groove turning

Scanalatura e copiatura assiale

UTS / KM

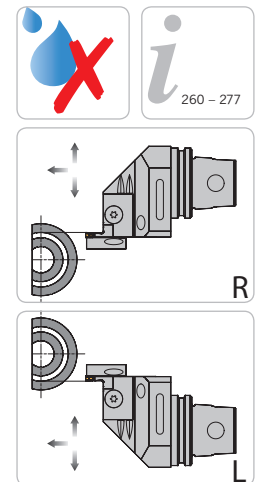
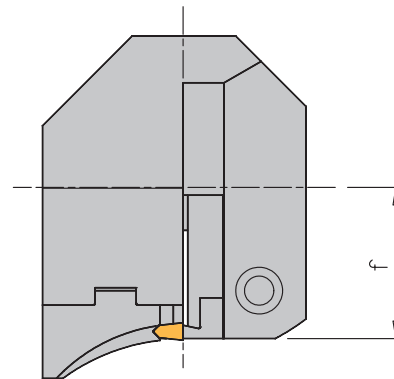
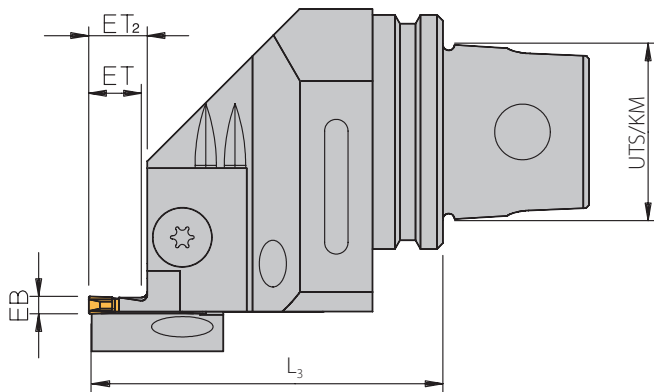

Rechte Ausführung abgebildet
 Right-hand execution shown
 Versione destra in figura

3

Trägerwerkzeuge / Holders / Utensili

Bezeichnung Designation Articolo	UTS/KM	f	L ₃	PG 43
UT32-2-3L/R	32	25,0	40,0	●
UT32-3-6L*	32	25,0	45,0	●
UT40-3-6L/R*	40	31,0	50,5	●
UT50-2-3R	50	25,0	45,0	●
UT50-3-6L/R*	50	36,0	56,0	●
UT63-3-6L/R*	63	42,0	57,0	●
UT63-8-10R	63	41,5	67,0	●

*Bei Stechbreite 6 mm --> Maß „f“ + 0,5 mm

*For width of cut 6 mm --> Dimension „f“ + 0,5 mm

*Per larghezza di taglio di 6 mm --> Dimensione „f“ + 0,5 mm

Grundhalter und Zubehör / Basic holder and accessories / Corpo utensile e accessori

Grundhalter Basic holder Corpo utensile	EB	ET	ET ₂	Nut-Außen-Ø OD of groove Ø est. di gola	U-Platte Support blade Lama	Klemme Clamp Staffa	Schneideinsatz Insert Inserto
UT32-2-3L/R UT50-2-3R	2	8,0	8,0	25 – 30	102-2530 R/L	KAM2 R/L	212....
	2	8,0	8,0	30 – 40	102-3040 R/L	KAM2 R/L	212....
	2	8,0	8,0	40 – 50	102-4050 R/L	KAM2 R/L	212....
	2	8,0	8,0	50 – 60	102-5060 R/L	KAM2 R/L	212....
	2	8,0	8,0	60 – 75	102-6075 R/L	KAM2 R/L	212....
	2	8,0	8,0	75 – 100	102-75100 R/L	KAM2 R/L	212....
	2	8,0	8,0	100 – 150	102-100150 R/L	KAM2 R/L	212....
	2	8,0	8,0	150 – 300	102-150300 R/L	KAM2 R/L	212....
	2	8,0	8,0	300 – 500	102-300500 R/L	KAM2 R/L	212....
	2	8,0	8,0	500 – ∞	10208 R/L*	KAM2 R/L	212....
	3	12,0	12,0	25 – 30	103-2530 R/L	KAM3 R/L	316....
	3	12,0	12,0	30 – 40	103-3040 R/L	KAM3 R/L	316....
	3	12,0	12,0	40 – 50	103-4050 R/L	KAM3 R/L	316....
	3	12,0	12,0	50 – 60	103-5060 R/L	KAM3 R/L	316....
	3	12,0	12,0	60 – 75	103-6075 R/L	KAM3 R/L	316....
	3	12,0	12,0	75 – 100	103-75100 R/L	KAM3 R/L	316....
	3	12,0	12,0	100 – 150	103-100150 R/L	KAM3 R/L	316....
	3	12,0	12,0	150 – 300	103-150300 R/L	KAM3 R/L	316....
	3	12,0	12,0	300 – 500	103-300500 R/L	KAM3 R/L	316....
	3	12,0	12,0	500 – ∞	10312 R/L*	KAM3 R/L	316....

*Nacharbeit für Durchmesserbereich erforderlich!

*Minimum retouching work required!

*Potrebbe essere necessaria leggera modifica!

Achtung: Schwerverspannklemme für NC-Stechdrehen, bei unterbrochenen Schnitten oder Vibrationen, siehe Seite 212.

Attention: Heavy duty clamp for NC-Groove turning, at interrupted cuts or vibrations, please refer to page 212.

Attenzione: Staffa a serraggio rinforzata, per taglio interrotto o in caso di vibrazioni, vedere pagina 212.

Weiteres Zubehör auf der nächsten Seite
More accessories next page
Altri accessori nella pagina seguente

Grundhalter und Zubehör / Basic holder and accessories / Corpo utensile e accessori

Grundhalter Basic holder Corpo utensile	EB	ET	ET ₂	Nut-Außen-Ø OD of groove Ø est. di gola	U-Platte Support blade Lama	Klemme Clamp Staffa	Schneideinsatz Insert Inserto
UT32-3-6L UT40-3-6L/R UT50-3-6L/R UT63-3-6L/R	3	9,5	9,5	50 – 60	203-5060 R/L	KA3 R/L	320....
	3	9,5	9,5	60 – 75	203-6075 R/L	KA3 R/L	320....
	3	9,5	9,5	75 – 100	203-75100 R/L	KA3 R/L	320....
	3	9,5	9,5	100 – 150	203-100150 R/L	KA3 R/L	320....
	3	9,5	9,5	150 – 300	203-150300 R/L	KA3 R/L	320....
	3	9,5	9,5	300 – 500	203-300500 R/L	KA3 R/L	320....
	3	9,5	9,5	500 – ∞	203-500XX R/L	KA3 R/L	320....
	3	16,0	18,5	50 – 60	UT3-5060 R/L	KT3 R/L	320....
	3	16,0	18,5	60 – 75	UT3-6075 R/L	KT3 R/L	320....
	3	16,0	18,5	75 – 100	UT3-75100 R/L	KT3 R/L	320....
	3	16,0	18,5	100 – 150	UT3-100150 R/L	KT3 R/L	320....
	3	16,0	18,5	150 – 300	UT3-150300 R/L	KT3 R/L	320....
	3	16,0	18,5	300 – 500	UT3-300500 R/L	KT3 R/L	320....
	3	16,0	18,5	500 – ∞	UT3-500XX R/L	KT3 R/L	320....
	4	11,5	11,5	50 – 60	204-5060 R/L	KA4 R/L	422....
	4	11,5	11,5	60 – 75	204-6075 R/L	KA4 R/L	422....
	4	11,5	11,5	75 – 100	204-75100 R/L	KA4 R/L	422....
	4	11,5	11,5	100 – 150	204-100150 R/L	KA4 R/L	422....
	4	11,5	11,5	150 – 300	204-150300 R/L	KA4 R/L	422....
	4	11,5	11,5	300 – 500	204-300500 R/L	KA4 R/L	422....
	4	11,5	11,5	500 – ∞	204-500XX R/L	KA4 R/L	422....
	4	19,0	21,5	50 – 60	UT4-5060 R/L	KT4 R/L	422....
	4	19,0	21,5	60 – 75	UT4-6075 R/L	KT4 R/L	422....
	4	19,0	21,5	75 – 100	UT4-75100 R/L	KT4 R/L	422....
	4	19,0	21,5	100 – 150	UT4-100150 R/L	KT4 R/L	422....
	4	19,0	21,5	150 – 300	UT4-150300 R/L	KT4 R/L	422....
	4	19,0	21,5	300 – 500	UT4-300500 R/L	KT4 R/L	422....
	4	19,0	21,5	500 – ∞	UT4-500XX R/L	KT4 R/L	422....
	5	14,5	14,5	50 – 60	205-5060 R/L	KA5 R/L	525....
	5	14,5	14,5	60 – 75	205-6075 R/L	KA5 R/L	525....
	5	14,5	14,5	75 – 100	205-75100 R/L	KA5 R/L	525....
	5	14,5	14,5	100 – 150	205-100150 R/L	KA5 R/L	525....
	5	14,5	14,5	150 – 300	205-150300 R/L	KA5 R/L	525....
	5	14,5	14,5	300 – 500	205-300500 R/L	KA5 R/L	525....
	5	14,5	14,5	500 – ∞	205-500XX R/L	KA5 R/L	525....
	5	22,0	24,5	50 – 60	UT5-5060 R/L	KT5 R/L	525....
5	22,0	24,5	60 – 75	UT5-6075 R/L	KT5 R/L	525....	
5	22,0	24,5	75 – 100	UT5-75100 R/L	KT5 R/L	525....	
5	22,0	24,5	100 – 150	UT5-100150 R/L	KT5 R/L	525....	
5	22,0	24,5	150 – 300	UT5-150300 R/L	KT5 R/L	525....	
5	22,0	24,5	300 – 500	UT5-300500 R/L	KT5 R/L	525....	
5	22,0	24,5	500 – ∞	UT5-500XX R/L	KT5 R/L	525....	
6	19,5	19,5	50 – 60	206-5060 R/L	KA6 R/L	630....	
6	19,5	19,5	60 – 75	206-6075 R/L	KA6 R/L	630....	
6	19,5	19,5	75 – 100	206-75100 R/L	KA6 R/L	630....	
6	19,5	19,5	100 – 150	206-100150 R/L	KA6 R/L	630....	
6	19,5	19,5	150 – 300	206-150300 R/L	KA6 R/L	630....	
6	19,5	19,5	300 – 500	206-300500 R/L	KA6 R/L	630....	
6	19,5	19,5	500 – ∞	206-500XX R/L	KA6 R/L	630....	
6	27,0	29,5	50 – 60	UT6-5060 R/L	KT6 R/L	630....	
6	27,0	29,5	60 – 75	UT6-6075 R/L	KT6 R/L	630....	
6	27,0	29,5	75 – 100	UT6-75100 R/L	KT6 R/L	630....	
6	27,0	29,5	100 – 150	UT6-100150 R/L	KT6 R/L	630....	
6	27,0	29,5	150 – 300	UT6-150300 R/L	KT6 R/L	630....	
6	27,0	29,5	300 – 500	UT6-300500 R/L	KT6 R/L	630....	
6	27,0	29,5	500 – ∞	UT6-500XX R/L	KT6 R/L	630....	

ET₂ = Stechtiefe kann auf Maß „ET₂“ erhöht werden.
 ET₂ = Grooving depth can be increased to measure "ET₂".
 ET₂ = La profondità di scanalatura può essere aumentata alla dimensione "ET₂".

Grundhalter werden mit Schrauben und Schlüssel geliefert, jedoch ohne U-Platte und Klemme.
 Basic holders will be supplied with screws and key, however without support blade and clamp.
 Gli steli sono forniti completi di viti e una chiave ma senza staffa e lama.

Weiteres Zubehör auf der nächsten Seite
 More accessories next page
 Altri accessori nella pagina seguente



Grundhalter und Zubehör / Basic holder and accessories / Corpo utensile e accessori

Grundhalter Basic holder Corpo utensile	EB	ET	ET ₂	Nut-Außen-Ø OD of groove Ø est. di gola	U-Platte Support blade Lama	Klemme Clamp Staffa	Schneideinsatz Insert Inserto
UT63-8-10R	8	17,0	18,0	75 – 100	308-75100 R/L	KAK8 R/L	838....
	8	17,0	18,0	100 – 150	308-100150 R/L	KAK8 R/L	838....
	8	17,0	18,0	150 – 300	308-150300 R/L	KAK8 R/L	838....
	8	17,0	18,0	300 – 500	308-300500 R/L	KAK8 R/L	838....
	8	17,0	18,0	500 – ∞	308-500XX R/L	KAK8 R/L	838....
	8	32,0	32,5	75 – 100	UT8-75100 R/L	KA8 R/L	838....
	8	32,0	32,5	100 – 150	UT8-100150 R/L	KA8 R/L	838....
	8	32,0	32,5	150 – 300	UT8-150300 R/L	KA8 R/L	838....
	8	32,0	32,5	300 – 500	UT8-300500 R/L	KA8 R/L	838....
	8	32,0	32,5	500 – ∞	UT8-500XX R/L	KA8 R/L	838....
	10	25,0	26,0	75 – 100	310-75100 R/L	KAK10 R/L	1046....
	10	25,0	26,0	100 – 150	310-100150 R/L	KAK10 R/L	1046....
	10	25,0	26,0	150 – 300	310-150300 R/L	KAK10 R/L	1046....
	10	25,0	26,0	300 – 500	310-300500 R/L	KAK10 R/L	1046....
	10	25,0	26,0	500 – ∞	310-500XX R/L	KAK10 R/L	1046....
	10	40,0	40,5	75 – 100	UT10-75100 R/L	KA10 R/L	1046....
	10	40,0	40,5	100 – 150	UT10-100150 R/L	KA10 R/L	1046....
	10	40,0	40,5	150 – 300	UT10-150300 R/L	KA10 R/L	1046....
	10	40,0	40,5	300 – 500	UT10-300500 R/L	KA10 R/L	1046....
10	40,0	40,5	500 – ∞	UT10-500XX R/L	KA10 R/L	1046....	

ET₂ = Stechtiefe kann auf Maß „ET₂“ erhöht werden.

ET₂ = Grooving depth can be increased to measure "ET₂".

ET₂ = La profondità di scanalatura può essere aumentata alla dimensione "ET₂".

Grundhalter werden mit Schrauben und Schlüssel geliefert, jedoch ohne U-Platte und Klemme.

Basic holders will be supplied with screws and key, however without support blade and clamp.

Gli steli sono forniti completi di viti e una chiave ma senza staffa e lama.

Ersatzteile / Spare Parts / Ricambi

Trägerwerkzeug Holder Utensile	Schraube Screw Vite	Schlüssel Key Chiave
UT32-3-6L - UT63-3-6L/R	T205	T5120
UT32-2-3L/R - UT50-2-3R	T154	KS 1111
UT63-8-10R	T206	T5120

Axial-Stechdrehen / Axial groove turning /
 Scanalatura e copiatura assiale

VDI

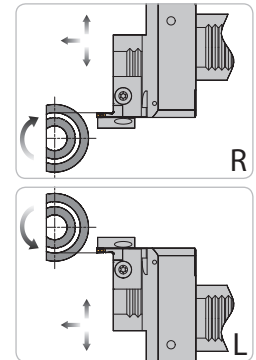
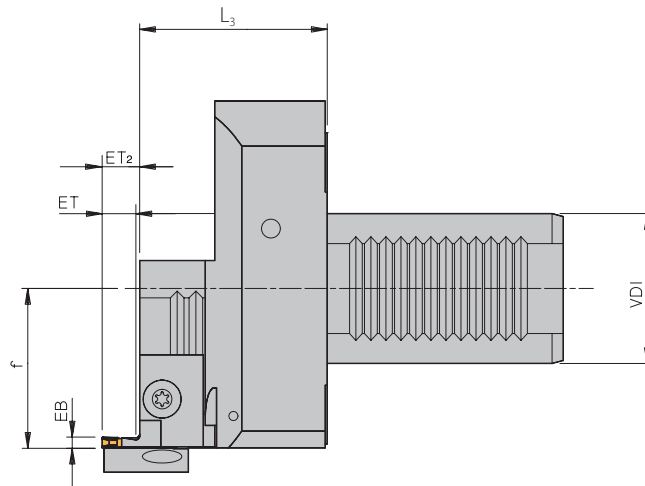

Rechte Ausführung abgebildet
 Right-hand execution shown
 Versione destra in figura



Trägerwerkzeuge / Holders / Utensili

Bezeichnung Designation Articolo	VDI	f	L ₃	PG 12
VDI30AX-L/R7	30	35,0	50	●
VDI40AX-L/R3*	40	42,5	60	●
VDI40AX-L/R7	40	42,5	50	●
VDI50AX-L/R3*	50	42,5	60	●
VDI50AX-L/R7	50	42,5	50	●
VDI60AX-L/R3*	60	42,5	60	●
VDI60AX-L/R7	60	42,5	50	●

*Bei Stechbreite 6 mm --> Maß „AKL“ + 0,5mm

*For width of cut 6 mm --> Dimension „AKL“ + 0,5mm

*Per larghezza di taglio di 6 mm --> Dimensione „AKL“ + 0,5 mm

Grundhalter und Zubehör / Basic holder and accessories / Corpo utensile e accessori

Grundhalter Basic holder Corpo utensile	EB	ET	ET ₂	Nut-Außen-Ø Ø of groove Ø est. di gola	U-Platte Support blade Lama	Klemme Clamp Staffa	Schneideinsatz Insert Inserto
VDI30AX-L/R7 VDI40AX-L/R7 VDI50AX-L/R7 VDI60AX-L/R7	3	9,5	9,5	50 – 60	203-5060 R/L	KA3 R/L	320....
	3	9,5	9,5	60 – 75	203-6075 R/L	KA3 R/L	320....
	3	9,5	9,5	75 – 100	203-75100 R/L	KA3 R/L	320....
	3	9,5	9,5	100 – 150	203-100150 R/L	KA3 R/L	320....
	3	9,5	9,5	150 – 300	203-150300 R/L	KA3 R/L	320....
	3	9,5	9,5	300 – 500	203-300500 R/L	KA3 R/L	320....
	3	9,5	9,5	500 – ∞	203-500XX R/L	KA3 R/L	320....
	3	16,0	18,5	50 – 60	UT3-5060 R/L	KT3 R/L	320....
	3	16,0	18,5	60 – 75	UT3-6075 R/L	KT3 R/L	320....
	3	16,0	18,5	75 – 100	UT3-75100 R/L	KT3 R/L	320....
	3	16,0	18,5	100 – 150	UT3-100150 R/L	KT3 R/L	320....
	3	16,0	18,5	150 – 300	UT3-150300 R/L	KT3 R/L	320....
	3	16,0	18,5	300 – 500	UT3-300500 R/L	KT3 R/L	320....
	3	16,0	18,5	500 – ∞	UT3-500XX R/L	KT3 R/L	320....
	4	11,5	11,5	50 – 60	204-5060 R/L	KA4 R/L	422....
	4	11,5	11,5	60 – 75	204-6075 R/L	KA4 R/L	422....
	4	11,5	11,5	75 – 100	204-75100 R/L	KA4 R/L	422....
	4	11,5	11,5	100 – 150	204-100150 R/L	KA4 R/L	422....
	4	11,5	11,5	150 – 300	204-150300 R/L	KA4 R/L	422....
	4	11,5	11,5	300 – 500	204-300500 R/L	KA4 R/L	422....

*Nacharbeit für Durchmesserbereich erforderlich!

*Minimum retouching work required!

*Potrebbe essere necessaria leggera modifica!

Achtung: Schwerspannklemme für NC-Stechdrehen, bei unterbrochenen Schnitten oder Vibrationen, siehe Seite 212.

Attention: Heavy duty clamp for NC-Groove turning, at interrupted cuts or vibrations, please refer to page 212.

Attenzione: Staffa a serraggio rinforzata, per taglio interrotto o in caso di vibrazioni, vedere pagina 212.

Weiteres Zubehör auf der nächsten Seite
 More accessories next page
 Altri accessori nella pagina seguente

Grundhalter und Zubehör / Basic holder and accessories / Corpo utensile e accessori

Grundhalter Basic holder Corpo utensile	EB	ET	ET ₂	Nut-Außen-Ø OD of groove Ø est. di gola	U-Platte Support blade Lama	Klemme Clamp Staffa	Schneideinsatz Insert Inserto
VDI30AX-L/R7 VDI40AX-L/R7 VDI50AX-L/R7 VDI60AX-L/R7	4	11,5	11,5	500 – ∞	204-500XX R/L	KA4 R/L	422....
	4	19,0	21,5	50 – 60	UT4-5060 R/L	KT4 R/L	422....
	4	19,0	21,5	60 – 75	UT4-6075 R/L	KT4 R/L	422....
	4	19,0	21,5	75 – 100	UT4-75100 R/L	KT4 R/L	422....
	4	19,0	21,5	100 – 150	UT4-100150 R/L	KT4 R/L	422....
	4	19,0	21,5	150 – 300	UT4-150300 R/L	KT4 R/L	422....
	4	19,0	21,5	300 – 500	UT4-300500 R/L	KT4 R/L	422....
	4	19,0	21,5	500 – ∞	UT4-500XX R/L	KT4 R/L	422....
	5	14,5	14,5	50 – 60	205-5060 R/L	KA5 R/L	525....
	5	14,5	14,5	60 – 75	205-6075 R/L	KA5 R/L	525....
	5	14,5	14,5	75 – 100	205-75100 R/L	KA5 R/L	525....
	5	14,5	14,5	100 – 150	205-100150 R/L	KA5 R/L	525....
	5	14,5	14,5	150 – 300	205-150300 R/L	KA5 R/L	525....
	5	14,5	14,5	300 – 500	205-300500 R/L	KA5 R/L	525....
	5	14,5	14,5	500 – ∞	205-500XX R/L	KA5 R/L	525....
	5	22,0	24,5	50 – 60	UT5-5060 R/L	KT5 R/L	525....
	5	22,0	24,5	60 – 75	UT5-6075 R/L	KT5 R/L	525....
	5	22,0	24,5	75 – 100	UT5-75100 R/L	KT5 R/L	525....
	5	22,0	24,5	100 – 150	UT5-100150 R/L	KT5 R/L	525....
	5	22,0	24,5	150 – 300	UT5-150300 R/L	KT5 R/L	525....
	5	22,0	24,5	300 – 500	UT5-300500 R/L	KT5 R/L	525....
	5	22,0	24,5	500 – ∞	UT5-500XX R/L	KT5 R/L	525....
	6	19,5	19,5	50 – 60	206-5060 R/L	KA6 R/L	630....
	6	19,5	19,5	60 – 75	206-6075 R/L	KA6 R/L	630....
	6	19,5	19,5	75 – 100	206-75100 R/L	KA6 R/L	630....
	6	19,5	19,5	100 – 150	206-100150 R/L	KA6 R/L	630....
	6	19,5	19,5	150 – 300	206-150300 R/L	KA6 R/L	630....
	6	19,5	19,5	300 – 500	206-300500 R/L	KA6 R/L	630....
	6	19,5	19,5	500 – ∞	206-500XX R/L	KA6 R/L	630....
	6	27,0	29,5	50 – 60	UT6-5060 R/L	KT6 R/L	630....
	6	27,0	29,5	60 – 75	UT6-6075 R/L	KT6 R/L	630....
	6	27,0	29,5	75 – 100	UT6-75100 R/L	KT6 R/L	630....
	6	27,0	29,5	100 – 150	UT6-100150 R/L	KT6 R/L	630....
6	27,0	29,5	150 – 300	UT6-150300 R/L	KT6 R/L	630....	
6	27,0	29,5	300 – 500	UT6-300500 R/L	KT6 R/L	630....	
6	27,0	29,5	500 – ∞	UT6-500XX R/L	KT6 R/L	630....	
VDI40AX-L/R3 VDI50AX-L/R3 VDI60AX-L/R3	8	17,0	18,0	75 – 100	308-75100 R/L	KAK8 R/L	838....
	8	17,0	18,0	100 – 150	308-100150 R/L	KAK8 R/L	838....
	8	17,0	18,0	150 – 300	308-150300 R/L	KAK8 R/L	838....
	8	17,0	18,0	300 – 500	308-300500 R/L	KAK8 R/L	838....
	8	17,0	18,0	500 – ∞	308-500XX R/L	KAK8 R/L	838....
	8	32,0	32,5	75 – 100	UT8-75100 R/L	KA8 R/L	838....
	8	32,0	32,5	100 – 150	UT8-100150 R/L	KA8 R/L	838....
	8	32,0	32,5	150 – 300	UT8-150300 R/L	KA8 R/L	838....
	8	32,0	32,5	300 – 500	UT8-300500 R/L	KA8 R/L	838....
	8	32,0	32,5	500 – ∞	UT8-500XX R/L	KA8 R/L	838....
	10	25,0	26,0	75 – 100	310-75100 R/L	KAK10 R/L	1046....
	10	25,0	26,0	100 – 150	310-100150 R/L	KAK10 R/L	1046....
	10	25,0	26,0	150 – 300	310-150300 R/L	KAK10 R/L	1046....
	10	25,0	26,0	300 – 500	310-300500 R/L	KAK10 R/L	1046....
	10	25,0	26,0	500 – ∞	310-500XX R/L	KAK10 R/L	1046....
	10	40,0	40,5	75 – 100	UT10-75100 R/L	KA10 R/L	1046....
	10	40,0	40,5	100 – 150	UT10-100150 R/L	KA10 R/L	1046....
	10	40,0	40,5	150 – 300	UT10-150300 R/L	KA10 R/L	1046....
	10	40,0	40,5	300 – 500	UT10-300500 R/L	KA10 R/L	1046....
	10	40,0	40,5	500 – ∞	UT10-500XX R/L	KA10 R/L	1046....

ET₂ = Stechtiefe kann auf Maß „ET₂“ erhöht werden.

ET₂ = Grooving depth can be increased to measure "ET₂".

ET₂ = La profondità di scanalatura può essere aumentata alla dimensione "ET₂".

Grundhalter werden mit Schrauben und Schlüssel geliefert, jedoch ohne U-Platte und Klemme.

Basic holders will be supplied with screws and key, however without support blade and clamp.

Gli steli sono forniti completi di viti e una chiave ma senza staffa e lama.

Weiteres Zubehör auf der nächsten Seite

More accessories next page

Altri accessori nella pagina seguente

Ersatzteile / Spare Parts / Ricambi

Trägerwerkzeug Holder Utensile	Schraube Screw Vite	Schlüssel Key Chiave
VDI30AX.. - VDI60AX..	T205	T5120

Axial-Stechdrehen gerade – Ø 20 - 300 mm

Axial groove turning straight - Ø 20 - 300 mm

Utensile dritto scanalatura e copiatura assiale - Ø 20 - 300 mm

Kontra

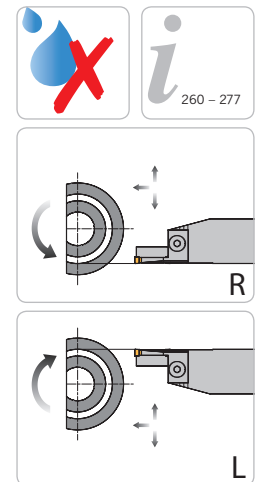
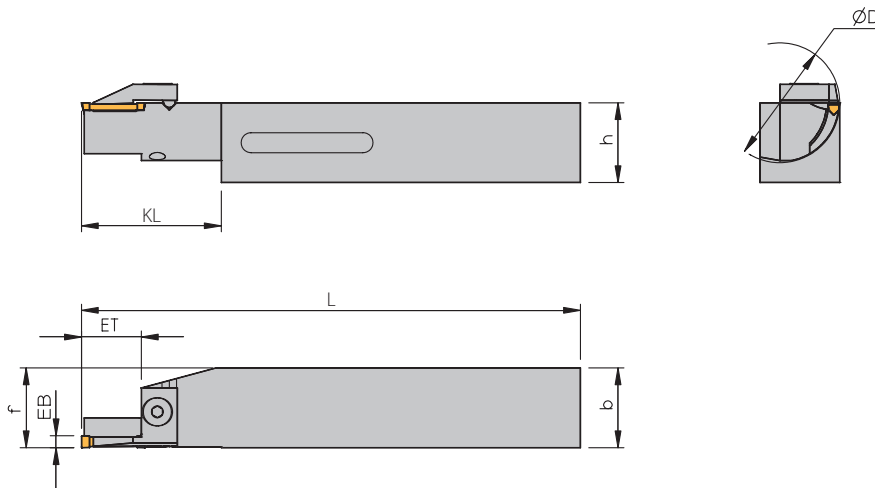

Rechte Ausführung abgebildet
 Right-hand execution shown
 Versione destra in figura

Trägerwerkzeuge / Holders / Utensili

Bezeichnung Designation Articolo	Nut-Außen-Ø OD of groove Ø est. di gola	EB	ET	KL	h	b	L	f	PG 12	Klemme Clamp Staffa	Schneideinsatz Insert Inserto
72020-2-2025L/R KONTRA	20-25	2	7,5	30	20	20	125	20	●	KAM2 R/L Kontra	212...
72020-2-2530L/R KONTRA	25-30	2	10,5	35	20	20	125	20	●	KTM2 R/L Kontra	212...
72020-2-3035L/R KONTRA	30-35	2	10,5	35	20	20	125	20	●	KTM2 R/L Kontra	212...
72020-2-3540L/R KONTRA	35-40	2	10,5	35	20	20	125	20	●	KTM2 R/L Kontra	212...
72020-2-4050L/R KONTRA	40-50	2	10,5	35	20	20	125	20	●	KTM2 R/L Kontra	212...
72020-2-5060L/R KONTRA	50-60	2	10,5	35	20	20	125	20	●	KTM2 R/L Kontra	212...
72020-2-6075L/R KONTRA	60-75	2	10,5	35	20	20	125	20	●	KTM2 R/L Kontra	212...
72020-2-75100L/R KONTRA	75-100	2	10,5	35	20	20	125	20	●	KTM2 R/L Kontra	212...
72020-2-100150L/R KONTRA	100-150	2	10,5	35	20	20	125	20	●	KTM2 R/L Kontra	212...
72020-2-150300L/R KONTRA	150-300	2	10,5	35	20	20	125	20	●	KTM2 R/L Kontra	212...
72020-3-2025L/R KONTRA	20-25	3	11,5	30	20	20	125	20	●	KAM3 R/L Kontra	316...
72020-3-2530L/R KONTRA	25-30	3	14,5	35	20	20	125	20	●	KTM3 R/L Kontra	316...
72020-3-3035L/R KONTRA	30-35	3	14,5	35	20	20	125	20	●	KTM3 R/L Kontra	316...
72020-3-3540L/R KONTRA	35-40	3	14,5	35	20	20	125	20	●	KTM3 R/L Kontra	316...
72020-3-4050L/R KONTRA	40-50	3	14,5	35	20	20	125	20	●	KTM3 R/L Kontra	316...
72020-3-5060L/R KONTRA	50-60	3	14,5	35	20	20	125	20	●	KTM3 R/L Kontra	316...

Grundhalter werden mit Schrauben und Schlüssel geliefert, jedoch ohne U-Platte und Klemme.

Holders will be supplied with screws and key, however without support blade and clamp.

I portautensili sono consegnati muniti di viti e di una chiave ma senza lama e staffa.

Achtung: Diese Werkzeuge nur nach der Schafthöhe (Maß „h“) ausrichten, da die Schneidkante über der Drehmitte liegt!

Attention: These tools should be set up according to dimension „h“ (shank-height), because the cuttingedge is above centre height!

Attenzione: Questi utensili devono essere montati secondo l'altezza „h“ del gambo, perchè il tagliente è sopra l'altezza del centro!

Hinweis: Kontra-Stechwerkzeuge ab Stechbreite 3 mm und Außendurchmesser 50 mm, siehe Seite 233.

Remark: Contra-execution grooving tools from the grooving width of 3 mm and external diameter of 50 mm, please refer to page 233.

Nota: Utensili Kontra partono da una larghezza di taglio di 3 mm, e diametro esterno 50 mm, vedere pagina 233.

Ersatzteile / Spare Parts / Ricambi

Trägerwerkzeug Holder Utensile	Schraube Screw Vite	Schlüssel Key Chiave
72020-2... - 72020-3...L/R Kontra	T154	KS 1111

Axial-Steindreher gerade / Axial groove turning straight /
 Utensile dritto - Scanalatura e copiatura assiale

Kontra

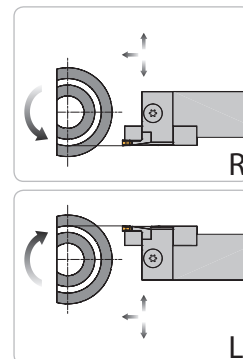
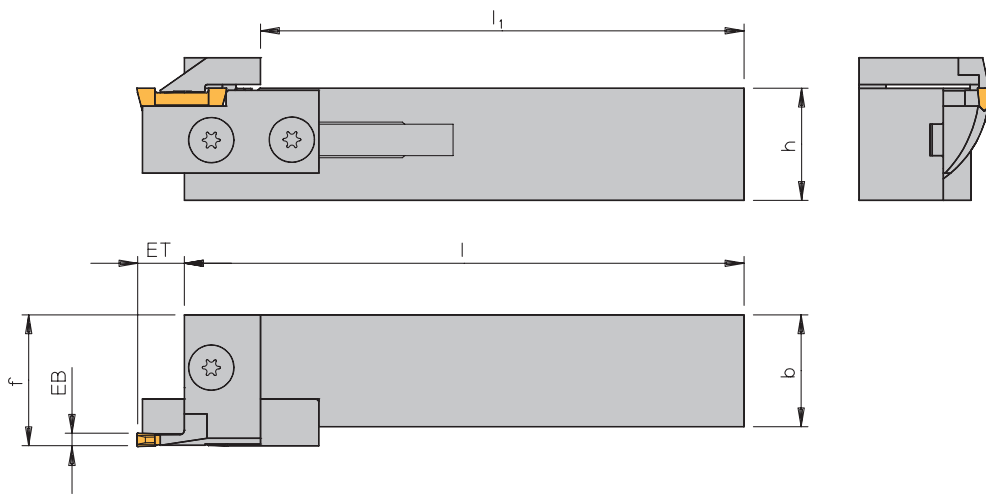

3

N NEU/NEW/
 NUOVO

Rechte Ausführung abgebildet
 Right-hand execution shown
 Versione destra in figura

Trägerwerkzeuge / Holders / Utensili

Bezeichnung Designation Articolo	h	b	l	l ₁	f	PG 12
72025L/R*	20	25	125	113	29,65	●
72525L/R*	25	25	150	138	29,65	●
73225L/R*	32	25	170	158	29,65	●
373225L/R	32	25	170	145	29,65	●
373232L/R	32	32	170	145	38,50	●

*Bei Stechbreite 6 mm --> f = b + 0,5; übrige Stechbreiten f = b

*For width of cut 6 mm --> f = b + 0.5; for all others f = b

*Per larghezza di taglio di 6 mm --> f = b + 0,5; altre larghezze f = b

Grundhalter und Zubehör / Basic holder and accessories / Corpo utensile e accessori

Grundhalter Basic holder Corpo utensile	EB	ET	Nut-Außen-Ø OD of groove Ø est. di gola	U-Platte Support blade Lama	Klemme Clamp Staffa	Schneideinsatz Insert Inserito
72025L/R 72525L/R 73225L/R	3	10	50 – 60	203S-5060 R/L Kontra	KAS3 R/L Kontra	320...
	3	10	60 – 75	203S-6075 R/L Kontra	KAS3 R/L Kontra	320...
	3	10	75 – 100	203S-75100 R/L Kontra	KAS3 R/L Kontra	320...
	3	10	100 – 150	203S-100150 R/L Kontra	KAS3 R/L Kontra	320...
	3	10	150 – 300	203S-150300 R/L Kontra	KAS3 R/L Kontra	320...
	3	10	300 – 500	203S-300500 R/L Kontra	KAS3 R/L Kontra	320...
	3	10	500 – ∞	203S-500XX R/L Kontra	KAS3 R/L Kontra	320...
	3	17	50 – 60	UT3S-5060 R/L Kontra	KTS3 R/L Kontra	320...
	3	17	60 – 75	UT3S-6075 R/L Kontra	KTS3 R/L Kontra	320...
	3	17	75 – 100	UT3S-75100 R/L Kontra	KTS3 R/L Kontra	320...
	3	17	100 – 150	UT3S-100150 R/L Kontra	KTS3 R/L Kontra	320...
	3	17	150 – 300	UT3S-150300 R/L Kontra	KTS3 R/L Kontra	320...
	3	17	300 – 500	UT3S-300500 R/L Kontra	KTS3 R/L Kontra	320...
	3	17	500 – ∞	UT3S-500XX R/L Kontra	KTS3 R/L Kontra	320...
	4	12	50 – 60	204S-5060 R/L Kontra	KAS4 R/L Kontra	422...
	4	12	60 – 75	204S-6075 R/L Kontra	KAS4 R/L Kontra	422...
	4	12	75 – 100	204S-75100 R/L Kontra	KAS4 R/L Kontra	422...
	4	12	100 – 150	204S-100150 R/L Kontra	KAS4 R/L Kontra	422...
4	12	150 – 300	204S-150300 R/L Kontra	KAS4 R/L Kontra	422...	
4	12	300 – 500	204S-300500 R/L Kontra	KAS4 R/L Kontra	422...	

Weiteres Zubehör auf der nächsten Seite
 More accessories next page
 Altri accessori nella pagina seguente

Grundhalter und Zubehör / Basic holder and accessories / Corpo utensile e accessori

Grundhalter Basic holder Corpo utensile	EB	ET	Nut-Außen-Ø OD of groove Ø est. di gola	U-Platte Support blade Lama	Klemme Clamp Staffa	Schneideinsatz Insert Inserto
72025L/R 72525L/R 73225L/R	4	12	500 – ∞	204S-500XX R/L Kontra	KAS4 R/L Kontra	422....
	4	20	50 – 60	UT4S-5060 R/L Kontra	KTS4 R/L Kontra	422....
	4	20	60 – 75	UT4S-6075 R/L Kontra	KTS4 R/L Kontra	422....
	4	20	75 – 100	UT4S-75100 R/L Kontra	KTS4 R/L Kontra	422....
	4	20	100 – 150	UT4S-100150 R/L Kontra	KTS4 R/L Kontra	422....
	4	20	150 – 300	UT4S-150300 R/L Kontra	KTS4 R/L Kontra	422....
	4	20	300 – 500	UT4S-300500 R/L Kontra	KTS4 R/L Kontra	422....
	4	20	500 – ∞	UT4S-500XX R/L Kontra	KTS4 R/L Kontra	422....
	5	15	50 – 60	205S-5060 R/L Kontra	KAS5 R/L Kontra	525....
	5	15	60 – 75	205S-6075 R/L Kontra	KAS5 R/L Kontra	525....
	5	15	75 – 100	205S-75100 R/L Kontra	KAS5 R/L Kontra	525....
	5	15	100 – 150	205S-100150 R/L Kontra	KAS5 R/L Kontra	525....
	5	15	150 – 300	205S-150300 R/L Kontra	KAS5 R/L Kontra	525....
	5	15	300 – 500	205S-300500 R/L Kontra	KAS5 R/L Kontra	525....
	5	15	500 – ∞	205S-500XX R/L Kontra	KAS5 R/L Kontra	525....
	5	23	50 – 60	UT5S-5060 R/L Kontra	KTS5 R/L Kontra	525....
	5	23	60 – 75	UT5S-6075 R/L Kontra	KTS5 R/L Kontra	525....
	5	23	75 – 100	UT5S-75100 R/L Kontra	KTS5 R/L Kontra	525....
	5	23	100 – 150	UT5S-100150 R/L Kontra	KTS5 R/L Kontra	525....
	5	23	150 – 300	UT5S-150300 R/L Kontra	KTS5 R/L Kontra	525....
	5	23	300 – 500	UT5S-300500 R/L Kontra	KTS5 R/L Kontra	525....
	5	23	500 – ∞	UT5S-500XX R/L Kontra	KTS5 R/L Kontra	525....
	6	20	50 – 60	206S-5060 R/L Kontra	KAS6 R/L Kontra	630....
	6	20	60 – 75	206S-6075 R/L Kontra	KAS6 R/L Kontra	630....
	6	20	75 – 100	206S-75100 R/L Kontra	KAS6 R/L Kontra	630....
	6	20	100 – 150	206S-100150 R/L Kontra	KAS6 R/L Kontra	630....
	6	20	150 – 300	206S-150300 R/L Kontra	KAS6 R/L Kontra	630....
	6	20	300 – 500	206S-300500 R/L Kontra	KAS6 R/L Kontra	630....
	6	20	500 – ∞	206S-500XX R/L Kontra	KAS6 R/L Kontra	630....
	6	28	50 – 60	UT6S-5060 R/L Kontra	KTS6 R/L Kontra	630....
	6	28	60 – 75	UT6S-6075 R/L Kontra	KTS6 R/L Kontra	630....
	6	28	75 – 100	UT6S-75100 R/L Kontra	KTS6 R/L Kontra	630....
6	28	100 – 150	UT6S-100150 R/L Kontra	KTS6 R/L Kontra	630....	
6	28	150 – 300	UT6S-150300 R/L Kontra	KTS6 R/L Kontra	630....	
6	28	300 – 500	UT6S-300500 R/L Kontra	KTS6 R/L Kontra	630....	
6	28	500 – ∞	UT6S-500XX R/L Kontra	KTS6 R/L Kontra	630....	
373225L/R 373232L/R	8	25	75 – 100	308S-75100 R/L Kontra	KAS8 R/L Kontra	838....
	8	25	100 – 150	308S-100150 R/L Kontra	KAS8 R/L Kontra	838....
	8	25	150 – 300	308S-150300 R/L Kontra	KAS8 R/L Kontra	838....
	8	25	300 – 500	308S-300500 R/L Kontra	KAS8 R/L Kontra	838....
	8	25	500 – ∞	308S-500XX R/L Kontra	KAS8 R/L Kontra	838....
	8	32	75 – 100	UT8S-75100 R/L Kontra	KTS8 R/L Kontra	838....
	8	32	100 – 150	UT8S-100150 R/L Kontra	KTS8 R/L Kontra	838....
	8	32	150 – 300	UT8S-150300 R/L Kontra	KTS8 R/L Kontra	838....
	8	32	300 – 500	UT8S-300500 R/L Kontra	KTS8 R/L Kontra	838....
	8	32	500 – ∞	UT8S-500XX R/L Kontra	KTS8 R/L Kontra	838....
	10	35	75 – 100	310S-75100 R/L Kontra	KAS10 R/L Kontra	1046....
	10	35	100 – 150	310S-100150 R/L Kontra	KAS10 R/L Kontra	1046....
	10	35	150 – 300	310S-150300 R/L Kontra	KAS10 R/L Kontra	1046....
	10	35	300 – 500	310S-300500 R/L Kontra	KAS10 R/L Kontra	1046....
	10	35	500 – ∞	310S-500XX R/L Kontra	KAS10 R/L Kontra	1046....
	10	42	75 – 100	UT10S-75100 R/L Kontra	KTS10 R/L Kontra	1046....
	10	42	100 – 150	UT10S-100150 R/L Kontra	KTS10 R/L Kontra	1046....
	10	42	150 – 300	UT10S-150300 R/L Kontra	KTS10 R/L Kontra	1046....
	10	42	300 – 500	UT10S-300500 R/L Kontra	KTS10 R/L Kontra	1046....
	10	42	500 – ∞	UT10S-500XX R/L Kontra	KTS10 R/L Kontra	1046....

Grundhalter werden mit Schrauben und Schlüssel geliefert, jedoch ohne U-Platte und Klemme.

Basic holders will be supplied with screws and key, however without support blade and clamp.

Gli steli sono forniti completi di viti e una chiave ma senza staffa e lama.

Weiteres Zubehör auf der nächsten Seite

More accessories next page

Altri accessori nella pagina seguente

Ersatzteile / Spare Parts / Ricambi

Trägerwerkzeug	Schraube	Schlüssel
<i>Holder</i>	<i>Screw</i>	<i>Key</i>
<i>Utensile</i>	<i>Vite</i>	<i>Chiave</i>
373225.. -373232..	T206	T5120
72025.. -73225..	T205	T5120

Radial-Stechdrehen gerade / Radial groove turning straight / Utensile dritto - Scanalatura e copiatura radiale

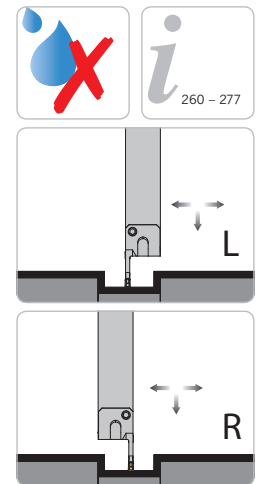
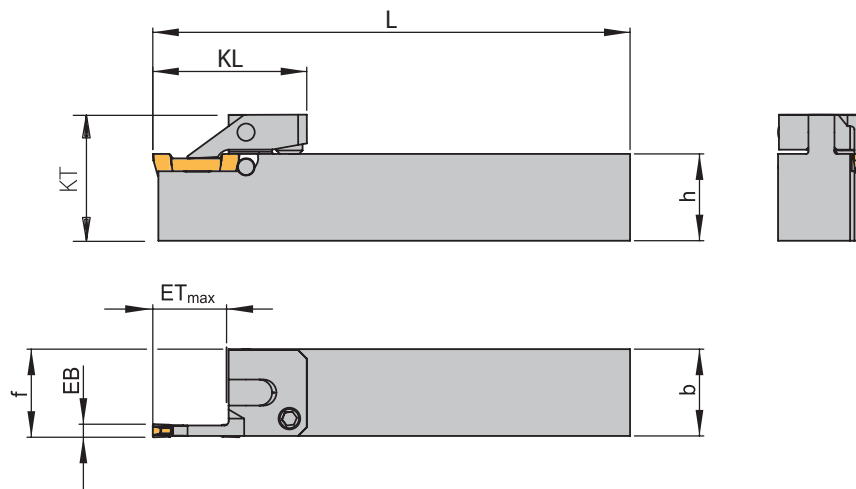

Rechte Ausführung abgebildet
Right-hand execution shown
Versione destra in figura

Trägerwerkzeuge / Holders / Utensili

Bezeichnung Designation Articolo	EB	ET _{max}	KL	KT	h	b	L	f	PG 12	Schneideinsatz Insert Inserto
SAN01-0317-1616L/R	3	17	35,5	25	16	16	100	16.3	●	320....
SAN01-0317-2020L/R	3	17	35,5	29	20	20	110	20.3	●	320....
SAN01-0317-2525L/R	3	17	35,5	34	25	25	125	25.3	●	320....
SAN01-0419-1616L/R	4	19	37,6	25	16	16	100	16.3	●	422....
SAN01-0419-2020L/R	4	19	37,6	29	20	20	110	20.3	●	422....
SAN01-0419-2525L/R	4	19	37,6	34	25	25	125	25.3	●	422....
SAN01-0522-2020L/R	5	22	40,6	29	20	20	110	20.3	●	525....
SAN01-0522-2525L/R	5	22	40,6	34	25	25	125	25.3	●	525....
SAN01-0627-2020L/R	6	27	45,7	29	20	20	110	20.3	●	630....
SAN01-0627-2525L/R	6	27	45,7	34	25	25	125	25.3	●	630....

Innenstechdrehen ab Ø 16 mm

Internal groove turning from Ø 16 mm

Scanalatura e copiatura interna da Ø 16 mm

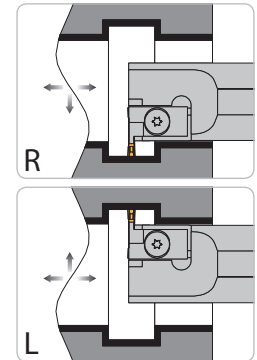
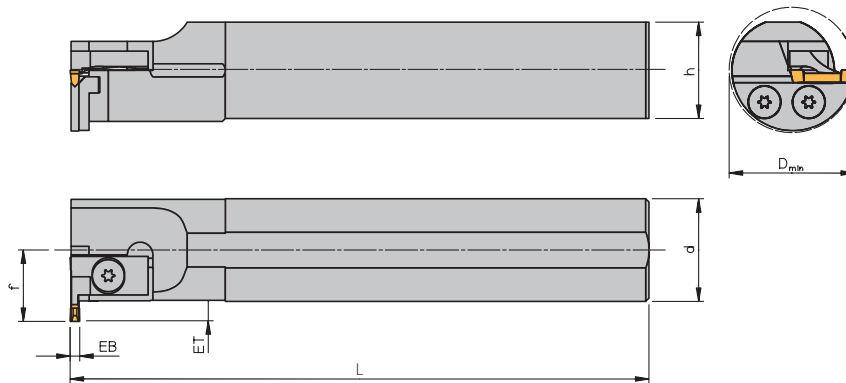

Rechte Ausführung abgebildet
 Right-hand execution shown
 Versione destra in figura

3

Trägerwerkzeuge / Holders / Utensili

Bezeichnung Designation Articolo	d	L	h	PG 12
9-12.471L/R	12	150	11	●
9-12L/R	12	150	11	●
9-16.2.471L/R	16	150	15	●
9-16.2L/R	16	150	15	●
9-16.3.471L/R	16	150	15	●
9-16.3L/R	16	150	15	●
9-20.471L/R	20	250	18	●
9-20L/R	20	250	18	●
9-25.471L/R	25	280	23	●
9-25L/R	25	280	23	●
9-32L/R	32	300	30	●

Grundhalter und Zubehör / Basic holder and accessories / Corpo utensile e accessori

Grundhalter Basic holder Corpo utensile	EB	ET	D _{min}	f	U-Platte Support blade Lama	Klemme Clamp Staffa	Schneideinsatz Insert Inserto
9-12L/R	2,00	3	16	9,0	-*	KI2F R/L	212....
9-12.471L/R	0,5 - 1,85	= EB	16	9,0	-*	KI2F R/L	2-../471 R/L
9-16.2L/R	2,00	3	20	11,0	-*	KI2F R/L	212....
9-16.2.471L/R	0,5 - 1,85	= EB	20	11,0	-*	KI2F R/L	2-../471 R/L
9-16.3L/R	3,00	4	21	12,0	-*	MKI3F R/L	316....
9-16.3.471L/R	0,5 - 3,08	= EB	21	12,0	-*	MKI3F R/L	3M-../471 R/L
9-20L/R	3,00	4	25	14,3	-*	KI3F R/L	320....
9-20.471L/R	0,5 - 3,08	= EB	25	14,3	-*	KI3F R/L	3-../471 R/L

Weiteres Zubehör auf der nächsten Seite
 More accessories next page
 Altri accessori nella pagina seguente

Grundhalter und Zubehör / Basic holder and accessories / Corpo utensile e accessori

Grundhalter Basic holder Corpo utensile	EB	ET	D _{min}	f	U-Platte Support blade Lama	Klemme Clamp Staffa	Schneideinsatz Insert Inserito
9-25L/R	3,00	4	30	16,8	–*	KI3F R/L	320....
9-25.471L/R	0,5 – 3,08	= EB	30	16,8	–*	KI3F R/L	3-../471 R/L
9-32L/R	0,5 – 3,08	= EB	39	22,0	UI 471 R/L	KI3W R/L	3-../471 R/L
9-32L/R	3,00	6	39	22,0	20306 R/L	KI3W R/L	320....
9-32L/R	4,00	8	41	24,0	20408 R/L	KI4W R/L	422....
9-32L/R	5,00	11	44	27,0	20511 R/L	KI5W R/L	525....

*Monoblockhalter

*Monoblock holders

*Utensili monoblocco

Grundhalter werden mit Schrauben und Schlüssel geliefert, jedoch ohne U-Platte und Klemme.

Basic holders will be supplied with screws and key, however without support blade and clamp.

Gli steli sono forniti completi di viti e una chiave ma senza staffa e lama.

Bitte beachten: Rechter Halter -> Linkes Zubehör
Linker Halter -> Rechtes Zubehör

Please note: Holder right-hand-design -> Left-hand spare parts
Holder left-hand-design -> Right-hand spare parts

Attenzione: Stelo destro -> accessori sinistri
Stelo sinistro -> accessori destri

3

Ersatzteile / Spare Parts / Ricambi

Trägerwerkzeug Holder Utensile	Schraube Screw Vite	Schlüssel Key Chiave
9-12L/R - 9-16..L/R	M154	KS 1111
9-20L/R - 9-25..L/R	T154	KS 1111
9-32L/R	T205	T5120

Innenstechdrehen ab Ø 25 mm

Internal groove turning from Ø 25 mm

Scanalatura e copiatura interna da Ø 25 mm

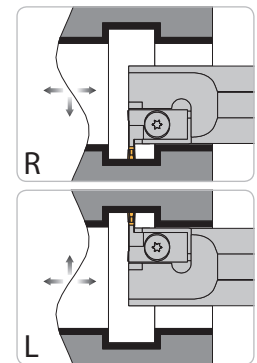
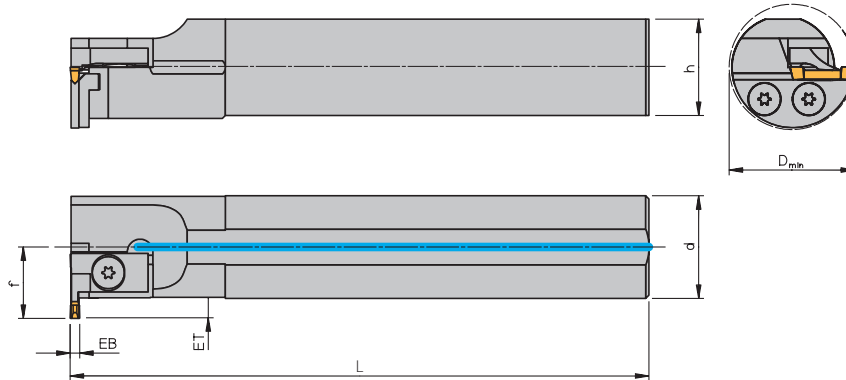

Rechte Ausführung abgebildet
Right-hand execution shown
Versione destra in figura

Trägerwerkzeuge / Holders / Utensili

Bezeichnung Designation Articolo	d	L	h	PG 12
9-20.471NCL/R	20	150	18	●
9-20NCL/R	20	150	18	●
9-25.471NCL/R	25	160	23	●
9-25NCL/R	25	160	23	●
9-32NCL/R	32	180	30	●
9-40NCL/R	40	240	38	●
9-50NCL/R	50	300	48	●
91-50NCL/R	50	300	48	●

Grundhalter und Zubehör / Basic holder and accessories / Corpo utensile e accessori

Grundhalter Basic holder Corpo utensile	EB	ET	D _{min}	f	U-Platte Support blade Lama	Klemme Clamp Staffa	Schneideinsatz Insert Inserto
9-20NCL/R	3,00	4	25	14,3	—*	KI3F R/L	320....
9-20.471NCL/R	0,5 – 3,08	= EB	25	14,3	—*	KI3F R/L	3-../471 R/L
9-25NCL/R	3,00	4	30	16,8	—*	KI3F R/L	320....
9-25.471NCL/R	0,5 – 3,08	= EB	30	16,8	—*	KI3F R/L	3-../471 R/L
9-32NCL/R	0,5 – 3,08	= EB	39	22,0	UI 471 R/L	KI3W R/L	3-../471 R/L
9-32NCL/R	3,00	6	39	22,0	20306 R/L	KI3W R/L	320....
9-32NCL/R	4,00	8	41	24,0	20408 R/L	KI4W R/L	422....
9-32NCL/R	5,00	11	44	27,0	20511 R/L	KI5W R/L	525....

Grundhalter und Zubehör / Basic holder and accessories / Corpo utensile e accessori

Grundhalter Basic holder Corpo utensile	EB	ET	D _{min}	f	U-Platte Support blade Lama	Klemme Clamp Staffa	Schneideinsatz Insert Inserto
9-40NCL/R	0,5 – 3,08	= EB	47	26,0	UI 471 R/L	KI3W R/L	3-../471 R/L
9-40NCL/R	3,00	6	47	26,0	20306 R/L	KI3W R/L	320....
9-40NCL/R	4,00	8	49	28,0	20408 R/L	KI4W R/L	422....
9-40NCL/R	5,00	11	52	31,0	20511 R/L	KI5W R/L	525....
9-50NCL/R	0,5 – 3,08	= EB	57	31,0	UI 471 R/L	KI3W R/L	3-../471 R/L
9-50NCL/R	3,00	6	57	31,0	20306 R/L	KI3W R/L	320....
9-50NCL/R	4,00	8	59	33,0	20408 R/L	KI4W R/L	422....
9-50NCL/R	5,00	11	62	36,0	20511 R/L	KI5W R/L	525....
91-50NCL/R	3,00	9	61	35,0	9-20310 R/L	KA3 R/L	320....
91-50NCL/R	3,00	15	70	44,0	9-UT 316 R/L	KT3 R/L	320....
91-50NCL/R	4,00	10	63	37,0	9-20412 R/L	KA4 R/L	422....
91-50NCL/R	4,00	18	73	47,0	9-UT 419 R/L	KT4 R/L	422....
91-50NCL/R	5,00	13	66	40,0	9-20515 R/L	KA5 R/L	525....
91-50NCL/R	5,00	21	76	50,0	9-UT 522 R/L	KT5 R/L	525....
91-50NCL/R	6,00	18	71	45,0	9-20620 R/L	KA6 R/L	630....
91-50NCL/R	6,00	26	81	55,0	9-UT 627 R/L	KT6 R/L	630....

*Monoblockhalter

*Monoblock holders

*Utensili monoblocco

Grundhalter werden mit Schrauben und Schlüssel geliefert, jedoch ohne U-Platte und Klemme.

Basic holders will be supplied with screws and key, however without support blade and clamp.

Gli steli sono forniti completi di viti e una chiave ma senza staffa e lama.

Bitte beachten: Rechter Halter -> Linkes Zubehör

Linker Halter -> Rechtes Zubehör

Please note: Holder right-hand-design -> Left-hand spare parts

Holder left-hand-design -> Right-hand spare parts

Attenzione: Stelo destro -> accessori sinistri

Stelo sinistro -> accessori destri

Ersatzteile / Spare Parts / Ricambi

Trägerwerkzeug Holder Utensile	Schraube Screw Vite	Schlüssel Key Chiave
9-20NCL/R - 9-25..	T154	KS 1111
9-32NCL/R - 91-50NCL/R	T205	T5120

Innenstechdrehen / Internal groove turning / Scanalatura interna
 UTS / KM

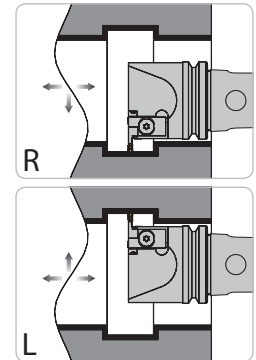
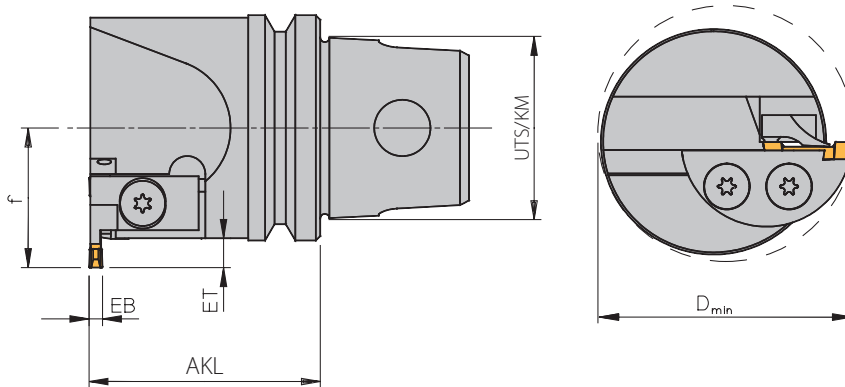

Rechte Ausführung abgebildet
 Right-hand execution shown
 Versione destra in figura

Trägerwerkzeuge / Holders / Utensili

Bezeichnung Designation Articolo	UTS/KM	AKL	PG 43
UT321-3-5L	32	40,0	●
UT401-3-5L/R	40	45,5	●
UT501-3-5L/R	50	51,0	●
UT501-3-6L	50	51,0	●

3

Grundhalter und Zubehör / Basic holder and accessories / Corpo utensile e accessori

Grundhalter Basic holder Corpo utensile	EB	ET	D _{min}	f	U-Platte Support blade Lama	Klemme Clamp Staffa	Schneideinsatz Insert Inserto
UT321-3-5L	0,5 - 3,08	= EB	39	22,0	UI471 R/L	KI3W R/L	3-../471 R/L
UT321-3-5L	3,00	6	39	22,0	20306 R/L	KI3W R/L	320....
UT321-3-5L	4,00	8	41	24,0	20408 R/L	KI4W R/L	422....
UT321-3-5L	5,00	11	44	27,0	20511 R/L	KI5W R/L	525....
UT401-3-5L/R	0,5 - 3,08	= EB	47	26,0	UI471 R/L	KI3W R/L	3-../471 R/L
UT401-3-5L/R	3,00	6	47	26,0	20306 R/L	KI3W R/L	320....
UT401-3-5L/R	4,00	8	49	28,0	20408 R/L	KI4W R/L	422....
UT401-3-5L/R	5,00	11	52	31,0	20511 R/L	KI5W R/L	525....

Weiteres Zubehör auf der nächsten Seite
 More accessories next page
 Altri accessori nella pagina seguente

Grundhalter und Zubehör / Basic holder and accessories / Corpo utensile e accessori

Grundhalter Basic holder Corpo utensile	EB	ET	D _{min}	f	U-Platte Support blade Lama	Klemme Clamp Staffa	Schneideinsatz Insert Inserto
UT50I-3-5L/R	0,5 – 3,08	= EB	57	31,0	UI471 R/L	KI3W R/L	3-../471 R/L
UT50I-3-5L/R	3,00	6	57	31,0	20306 R/L	KI3W R/L	320....
UT50I-3-5L/R	4,00	8	59	33,0	20408 R/L	KI4W R/L	422....
UT50I-3-5L/R	5,00	11	62	36,0	20511 R/L	KI5W R/L	525....

Grundhalter werden mit Schrauben und Schlüssel geliefert, jedoch ohne U-Platte und Klemme.

Basic holders will be supplied with screws and key, however without support blade and clamp.

Gli steli sono forniti completi di viti e una chiave ma senza staffa e lama.

Bitte beachten: Rechter Halter -> Linkes Zubehör

Linker Halter -> Rechtes Zubehör

Please note: Holder right-hand-design -> Left-hand spare parts

Holder left-hand-design -> Right-hand spare parts

Attenzione: Stelo destro -> accessori sinistri

Stelo sinistro -> accessori destri



Ersatzteile / Spare Parts / Ricambi

Trägerwerkzeug Holder Utensile	Schraube Screw Vite	Schlüssel Key Chiave
UT32I.. - UT50I..	T205	T5120

Axial-Stechdrehen gerade

Axial groove turning straight

Utensile dritto - Scanalatura e copiatura assiale

Kontra

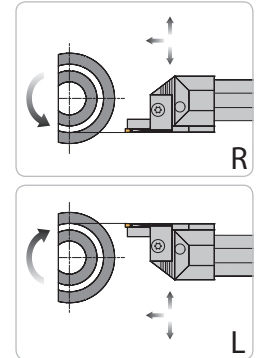
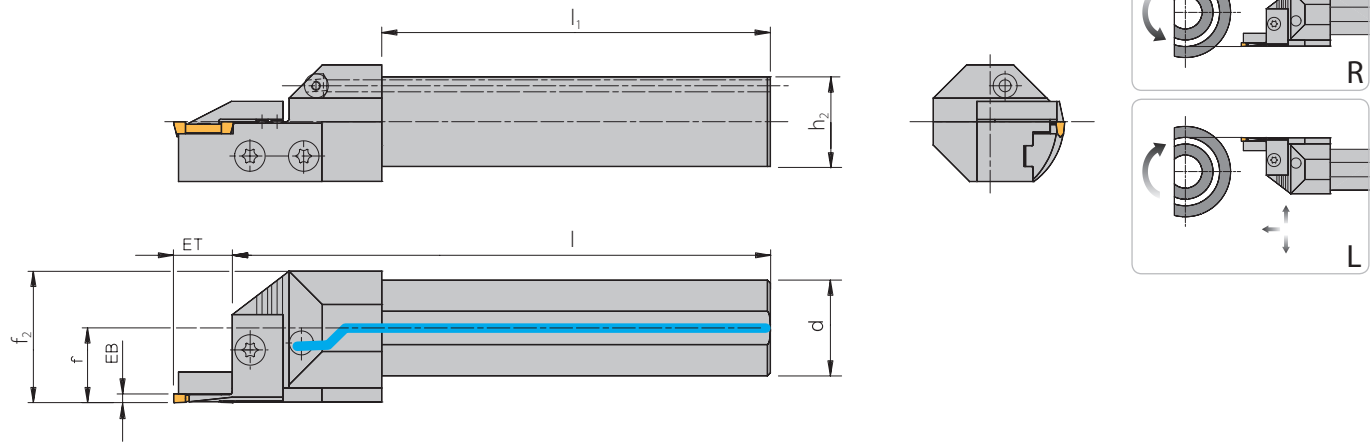

Rechte Ausführung abgebildet
 Right-hand execution shown
 Versione destra in figura

3

Trägerwerkzeuge / Holders / Utensili

Bezeichnung Designation Articolo	d	l	l ₁	f ₂	h ₂	f	PG 12
732NCL/R*	32	180	130	44	30	25,0	●
740NCL/R*	40	240	190	45	38	25,0	●
750NCL/R*	50	300	250	55	48	30,0	●
37-50NCL/R**	50	300	240	56	48	31,5	●

* Bei Stechbreite 6 mm -> f = b + 0,5; übrige Stechbreiten f = b
 * For width of cut 6 mm -> f = b + 0.5; for all others f = b
 * Per larghezza di taglio di 6 mm -> f = b + 0,5; altre larghezze f = b

**Halter erst ab Durchmesser 60 mm verwendbar
 **A holder can only be used with a diameter of 60 mm
 **Questo utensile è previsto per un diametro minimo di lavoro di 60 mm

Grundhalter und Zubehör / Basic holder and accessories / Corpo utensile e accessori

Grundhalter Basic holder Corpo utensile	EB	ET	Nut-Außen-Ø OD of groove Ø est. di gola	U-Platte Support blade Lama	Klemme Clamp Staffa	Schneideinsatz Insert Inserto
732NCL/R 740NCL/R 750NCL/R	3	10	50 – 60	203S-5060 R/L Kontra	KAS3 R/L Kontra	320...
	3	10	60 – 75	203S-6075 R/L Kontra	KAS3 R/L Kontra	320...
	3	10	75 – 100	203S-75100 R/L Kontra	KAS3 R/L Kontra	320...
	3	10	100 – 150	203S-100150 R/L Kontra	KAS3 R/L Kontra	320...
	3	10	150 – 300	203S-150300 R/L Kontra	KAS3 R/L Kontra	320...
	3	10	300 – 500	203S-300500 R/L Kontra	KAS3 R/L Kontra	320...
	3	10	500 – ∞	203S-500XX R/L Kontra	KAS3 R/L Kontra	320...
	3	17	50 – 60	UT3S-5060 R/L Kontra	KTS3 R/L Kontra	320...
	3	17	60 – 75	UT3S-6075 R/L Kontra	KTS3 R/L Kontra	320...
	3	17	75 – 100	UT3S-75100 R/L Kontra	KTS3 R/L Kontra	320...
	3	17	100 – 150	UT3S-100150 R/L Kontra	KTS3 R/L Kontra	320...
	3	17	150 – 300	UT3S-150300 R/L Kontra	KTS3 R/L Kontra	320...
	3	17	300 – 500	UT3S-300500 R/L Kontra	KTS3 R/L Kontra	320...
	3	17	500 – ∞	UT3S-500XX R/L Kontra	KTS3 R/L Kontra	320...
	4	12	50 – 60	204S-5060 R/L Kontra	KAS4 R/L Kontra	422...
	4	12	60 – 75	204S-6075 R/L Kontra	KAS4 R/L Kontra	422...
	4	12	75 – 100	204S-75100 R/L Kontra	KAS4 R/L Kontra	422...
	4	12	100 – 150	204S-100150 R/L Kontra	KAS4 R/L Kontra	422...
4	12	150 – 300	204S-150300 R/L Kontra	KAS4 R/L Kontra	422...	
4	12	300 – 500	204S-300500 R/L Kontra	KAS4 R/L Kontra	422...	

Weiteres Zubehör auf der nächsten Seite
 More accessories next page
 Altri accessori nella pagina seguente

Grundhalter und Zubehör / Basic holder and accessories / Corpo utensile e accessori

Grundhalter Basic holder Corpo utensile	EB	ET	Nut-Außen-Ø OD of groove Ø est. di gola	U-Platte Support blade Lama	Klemme Clamp Staffa	Schneideinsatz Insert Inserto
732NCL/R 740NCL/R 750NCL/R	4	12	500 – ∞	204S-500XX R/L Kontra	KAS4 R/L Kontra	422....
	4	20	50 – 60	UT4S-5060 R/L Kontra	KTS4 R/L Kontra	422....
	4	20	60 – 75	UT4S-6075 R/L Kontra	KTS4 R/L Kontra	422....
	4	20	75 – 100	UT4S-75100 R/L Kontra	KTS4 R/L Kontra	422....
	4	20	100 – 150	UT4S-100150 R/L Kontra	KTS4 R/L Kontra	422....
	4	20	150 – 300	UT4S-150300 R/L Kontra	KTS4 R/L Kontra	422....
	4	20	300 – 500	UT4S-300500 R/L Kontra	KTS4 R/L Kontra	422....
	4	20	500 – ∞	UT4S-500XX R/L Kontra	KTS4 R/L Kontra	422....
	5	15	50 – 60	205S-5060 R/L Kontra	KAS5 R/L Kontra	525....
	5	15	60 – 75	205S-6075 R/L Kontra	KAS5 R/L Kontra	525....
	5	15	75 – 100	205S-75100 R/L Kontra	KAS5 R/L Kontra	525....
	5	15	100 – 150	205S-100150 R/L Kontra	KAS5 R/L Kontra	525....
	5	15	150 – 300	205S-150300 R/L Kontra	KAS5 R/L Kontra	525....
	5	15	300 – 500	205S-300500 R/L Kontra	KAS5 R/L Kontra	525....
	5	15	500 – ∞	205S-500XX R/L Kontra	KAS5 R/L Kontra	525....
	5	23	50 – 60	UT5S-5060 R/L Kontra	KTS5 R/L Kontra	525....
	5	23	60 – 75	UT5S-6075 R/L Kontra	KTS5 R/L Kontra	525....
	5	23	75 – 100	UT5S-75100 R/L Kontra	KTS5 R/L Kontra	525....
	5	23	100 – 150	UT5S-100150 R/L Kontra	KTS5 R/L Kontra	525....
	5	23	150 – 300	UT5S-150300 R/L Kontra	KTS5 R/L Kontra	525....
	5	23	300 – 500	UT5S-300500 R/L Kontra	KTS5 R/L Kontra	525....
	5	23	500 – ∞	UT5S-500XX R/L Kontra	KTS5 R/L Kontra	525....
	6	20	50 – 60	206S-5060 R/L Kontra	KAS6 R/L Kontra	630....
	6	20	60 – 75	206S-6075 R/L Kontra	KAS6 R/L Kontra	630....
	6	20	75 – 100	206S-75100 R/L Kontra	KAS6 R/L Kontra	630....
	6	20	100 – 150	206S-100150 R/L Kontra	KAS6 R/L Kontra	630....
	6	20	150 – 300	206S-150300 R/L Kontra	KAS6 R/L Kontra	630....
	6	20	300 – 500	206S-300500 R/L Kontra	KAS6 R/L Kontra	630....
	6	20	500 – ∞	206S-500XX R/L Kontra	KAS6 R/L Kontra	630....
	6	28	50 – 60	UT6S-5060 R/L Kontra	KTS6 R/L Kontra	630....
	6	28	60 – 75	UT6S-6075 R/L Kontra	KTS6 R/L Kontra	630....
	6	28	75 – 100	UT6S-75100 R/L Kontra	KTS6 R/L Kontra	630....
6	28	100 – 150	UT6S-100150 R/L Kontra	KTS6 R/L Kontra	630....	
6	28	150 – 300	UT6S-150300 R/L Kontra	KTS6 R/L Kontra	630....	
6	28	300 – 500	UT6S-300500 R/L Kontra	KTS6 R/L Kontra	630....	
6	28	500 – ∞	UT6S-500XX R/L Kontra	KTS6 R/L Kontra	630....	
37-50NCL/R	8	25	75 – 100	308S-75100 R/L Kontra	KAS8 R/L Kontra	838....
	8	25	100 – 150	308S-100150 R/L Kontra	KAS8 R/L Kontra	838....
	8	25	150 – 300	308S-150300 R/L Kontra	KAS8 R/L Kontra	838....
	8	25	300 – 500	308S-300500 R/L Kontra	KAS8 R/L Kontra	838....
	8	25	500 – ∞	308S-500XX R/L Kontra	KAS8 R/L Kontra	838....
	8	32	75 – 100	UT8S-75100 R/L Kontra	KTS8 R/L Kontra	838....
	8	32	100 – 150	UT8S-100150 R/L Kontra	KTS8 R/L Kontra	838....
	8	32	150 – 300	UT8S-150300 R/L Kontra	KTS8 R/L Kontra	838....
	8	32	300 – 500	UT8S-300500 R/L Kontra	KTS8 R/L Kontra	838....
	8	32	500 – ∞	UT8S-500XX R/L Kontra	KTS8 R/L Kontra	838....
	10	35	75 – 100	310S-75100 R/L Kontra	KAS10 R/L Kontra	1046....
	10	35	100 – 150	310S-100150 R/L Kontra	KAS10 R/L Kontra	1046....
	10	35	150 – 300	310S-150300 R/L Kontra	KAS10 R/L Kontra	1046....
	10	35	300 – 500	310S-300500 R/L Kontra	KAS10 R/L Kontra	1046....
	10	35	500 – ∞	310S-500XX R/L Kontra	KAS10 R/L Kontra	1046....
	10	42	75 – 100	UT10S-75100 R/L Kontra	KTS10 R/L Kontra	1046....
	10	42	100 – 150	UT10S-100150 R/L Kontra	KTS10 R/L Kontra	1046....
	10	42	150 – 300	UT10S-150300 R/L Kontra	KTS10 R/L Kontra	1046....
	10	42	300 – 500	UT10S-300500 R/L Kontra	KTS10 R/L Kontra	1046....
	10	42	500 – ∞	UT10S-500XX R/L Kontra	KTS10 R/L Kontra	1046....

Grundhalter werden mit Schrauben und Schlüssel geliefert, jedoch ohne U-Platte und Klemme.

Basic holders will be supplied with screws and key, however without support blade and clamp.

Gli steli sono forniti completi di viti e una chiave ma senza staffa e lama.

Weiteres Zubehör auf der nächsten Seite

More accessories next page

Altri accessori nella pagina seguente

Ersatzteile / Spare Parts / Ricambi

Trägerwerkzeug Holder Utensile	Schraube Screw Vite	Schlüssel Key Chiave
732NCL/R - 750NCL/R	T205	T5120
37-50NCL/R	T206	T5120

Innenstechdrehen / Internal groove turning / Scanalatura interna

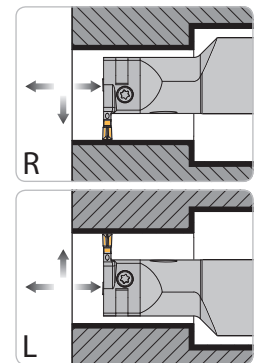
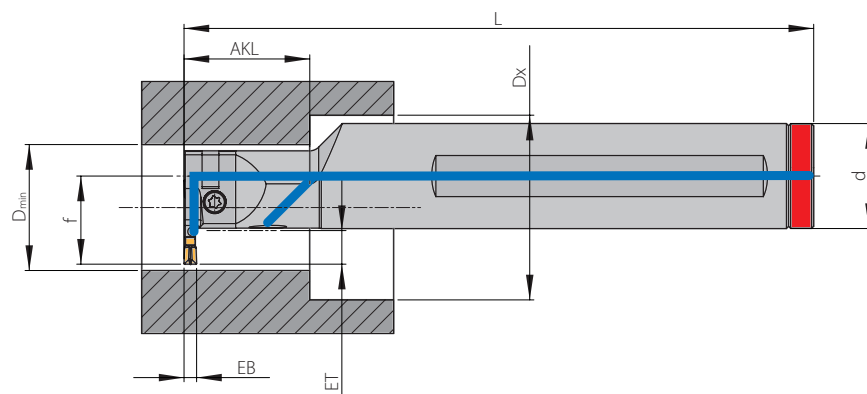

Rechte Ausführung abgebildet
Right-hand execution shown
Versione destra in figura





3

Trägerwerkzeuge / Holders / Utensili

Bezeichnung Designation Articolo	D _{min}	EB	ET	AKL	d	L	f	D _x	PG 12	Schneideinsatz Insert Inserto
SIN20M-045-20-16L/R	16	2	4,5	20	16	110	13,0	27,5	●	212...
SIN20M-045-30-16L/R	16	2	4,5	30	16	110	13,0	27,5	●	212...
SIN30-080-30-20L/R	28	3	8,0	30	20	135	18,5	31,0	●	320...
SIN30-080-30-25L/R	28	3	8,0	30	25	150	21,0	41,0	●	320...
SIN30-080-50-20L/R	28	3	8,0	50	20	135	18,5	31,0	●	320...
SIN30-080-50-25L/R	28	3	8,0	50	25	150	21,0	41,0	●	320...
SIN30-110-30-25L/R	32	3	11,0	30	25	150	24,0	43,0	●	320...
SIN30-110-50-25L/R	32	3	11,0	50	25	150	24,0	43,0	●	320...
SIN30M-055-27-20L/R	20	3	5,5	27	20	135	16,5	33,0	●	316...
SIN30M-055-40-20L/R	20	3	5,5	40	20	135	16,5	33,0	●	316...

Ersatzteile / Spare Parts / Ricambi

Trägerwerkzeug Holder Utensile	Schraube Screw Vite	Verschlussring Locking Ring Anello di tenuta
SIN20M...-16L/R	AS 0018	KVR 16
SIN30...-20L/R	SS 1111	KVR 20
SIN30...-25L/R	SS 1111	KVR 25
SIN30M...-20L/R	AS 0019	KVR 20

	<p>Standardausführung</p> <ul style="list-style-type: none"> • präzisionsgeschliffener Schneideinsatz • zweiseitig • spezielle Geometrie zur Spaneinschnürung • zum Einstechen bei kleinen bis mittleren Spanquerschnitten • geringe Schnittkräfte durch scharfe Schneidkante • für eine Vielzahl von Werkstückstoffen • für Innen- und Außenbearbeitung 	<p><i>Standard geometry</i></p> <ul style="list-style-type: none"> • <i>precision ground insert</i> • <i>two cutting edges</i> • <i>special geometry with chip-contraction</i> • <i>for grooving with small to medium chip-cross-section</i> • <i>low cutting forces because of sharp cutting edges</i> • <i>for a number of workpiece materials</i> • <i>for internal and external machining</i> 	<p>Esecuzione standard</p> <ul style="list-style-type: none"> • inserto rettificato di precisione • 2 taglienti • geometria speciale adatta alla contrazione del truciolo • per una scanalatura di sezioni di truciolo piccole e medie • taglio dolce per il tagliente affilato • adatto ad un vasto numero di materiali • uso interno ed esterno
	<p>Kopierausführung -12</p> <ul style="list-style-type: none"> • präzisionsgeschliffener Schneideinsatz • zweiseitig • spezielle Geometrie zur Spaneinschnürung • mit 12° positivem Spanwinkel an allen drei Hauptschneiden • Anwendung entspricht der Standardausführung, jedoch zusätzlich zum Kopierdrehen bei mittleren Spanquerschnitten • für Innen- und Außenbearbeitung 	<p><i>Geometry for copying -12</i></p> <ul style="list-style-type: none"> • <i>precision ground insert</i> • <i>two cutting edges</i> • <i>special geometry for chip-contraction</i> • <i>12° positive rake angle on all three cutting edges</i> • <i>same application as standard execution, but also for copy-turning with medium chip-cross-section</i> • <i>for internal and external machining</i> 	<p>Geometria di copiatura -12</p> <ul style="list-style-type: none"> • inserto rettificato di precisione • 2 taglienti • geometria speciale adatta alla contrazione del truciolo • angolo di taglio a 12° positivo, tri-direzionale • medesima applicazione dell'esecuzione standard, ma adatto alla tornitura di sezioni di truciolo piccole e medie • uso interno ed esterno
	<p>AM-Geometrie</p> <ul style="list-style-type: none"> • präzisionsgesinterter 2-seitiger Schneideinsatz • Schneideinsatz zum Stechdrehen, Ein- und Abstechen • hohe Zerspanungsleistung durch stabile Schneidkante • geringe Schnittkräfte durch positive Schneidengeometrie • für Innen- und Außenbearbeitung 	<p><i>AM geometry</i></p> <ul style="list-style-type: none"> • <i>precision sintered twin edge inserts</i> • <i>inserts for groove turning, cut in and withdraw</i> • <i>considerable chip removal via stable cutting edge</i> • <i>minimum cutting force via positive cutting geometry</i> • <i>for internal and external machining</i> 	<p>Geometria AM</p> <ul style="list-style-type: none"> • inserto sinterizzato a 2 tagli • inserto per tornitura di scanalatura • considerevole volume di truciolo grazie alla stabilità del tagliente • taglio dolce per la geometria di taglio positiva • uso interno ed esterno
	<p>Vollradiusausführung V</p> <ul style="list-style-type: none"> • präzisionsgeschliffener Schneideinsatz • zweiseitig • Vollradius • für Einstiche und Nachkopieroperationen bei kleinen Spanquerschnitten • Zerspanung kurzspanender Werkstoffe • für Innen- und Außenbearbeitung 	<p><i>Full radius execution V</i></p> <ul style="list-style-type: none"> • <i>precision ground insert</i> • <i>two cutting edges</i> • <i>full radius</i> • <i>for grooving and copy-turning operations with small chip-cross-section</i> • <i>machining of short chipping materials</i> • <i>for internal and external machining</i> 	<p>Esecuzione a raggio completo V</p> <ul style="list-style-type: none"> • inserto rettificato di precisione • 2 taglienti • raggio completo • per scanalatura e copiatura di ridotte sezioni di taglio • lavorazione di materiali a truciolo corto • uso interno ed esterno



Vollradiusausführung VK

- präzisionsgeschliffener Schneideinsatz
- zweiseitig, Vollradius
- für Einstiche und Nachkopieroperationen bei entsprechenden Konturen bis mittlere Spanquerschnitte

Besonderheit:

- spezielle Spanformgeometrie für kontrollierten Spanbruch auch bei langspanenden Werkstoffen
- für Innen- und Außenbearbeitung

Full radius execution VK

- precision ground insert
- two cutting edges, full radius
- for grooving and copy-turning operations up to medium chip-cross-section

Particularity:

- special chipbreaker for controlled-chipbreaking when machining long chipping materials
- for internal and external machining

Esecuzione a raggio completo VK

- inserto rettificato di precisione
- 2 taglienti, raggio completo
- per scanalatura e copiatura di sezioni di truciolo medie

Particolarità:

- geometria adatta al controllo del truciolo di materiali a truciolo lungo
- uso interno ed esterno

3



Aluminiumausführung -ALU

- präzisionsgeschliffener Schneideinsatz
- zweiseitig
- spezielle Geometrie zur Spaneinschnürung
- mit 25° positivem Spanwinkel an allen drei Hauptschneiden
- für Einstich- und Kopierarbeiten bei NE-Metallen und Kunststoff
- für Innen- und Außenbearbeitung

Aluminium type -ALU

- precision ground insert
- two cutting edges
- special geometry for chip-contraction
- 25° positive rake angle on all three cutting edges
- grooving and copy-turning of non-ferrous materials and plastics
- for internal and external machining

Geometria -ALU

- inserto rettificato di precisione
- 2 taglienti
- geometria adatta specificamente alla contrazione del truciolo
- angolo di taglio a 25° positivo, tri-direzionale
- per scanalatura e copiatura di materiali non ferrosi e plastici
- uso interno ed esterno



Ausführung für Sicherungsringestiche

- präzisionsgeschliffener Schneideinsatz
- zweiseitig
- für alle Einstiche nach DIN 471/472 unter Verwendung von nur einer Unterstützplatte
- für Innen- und Außenbearbeitung

Circlip grooves execution

- precision ground insert
- two cutting edges
- for all grooves to DIN 471/472 by using only one support blade for all widths
- for internal and external machining

Esecuzioni per canali

- inserto rettificato di precisione
- 2 taglienti
- per gole secondo norma DIN 471/472 usando una sola lama per tutti gli spessori
- uso interno ed esterno

Beschichtet / Coated / Rivestito

AM27C

CVD-Mehrlagenbeschichtung

Bearbeitung von Stahl, Stahlguss mit mittleren bis hohen Schnittgeschwindigkeiten, mittleren bis großen Spanquerschnitten und wechselnden Schnitttiefen. Speziell einsetzbar für Stähle mit starker Verklebneigung. Einsatz im Schlicht- und mittleren Schruppbereich.

CVD-multilayer coating

Machining steel, cast steel as well as grey cast iron, at medium to high cutting speeds, medium to large chip-cross-sections and varying depths of cut. Used for finishing and medium roughing.

Rivestimento multistrato CVD

Lavorazione di acciaio, acciaio da fusione con velocità di taglio da medie ad elevate, sezioni di truciolo medie e larghe e profondità di taglio varie. Per finitura e media sgrossatura.

AM35C

CVD-Mehrlagenbeschichtung

Bearbeitung von Stahl, rostfreiem Stahl sowie Stahlguss bei mittleren bis großen Spanquerschnitten und mittleren bis geringen Schnittgeschwindigkeiten unter ungünstigen Bearbeitungsbedingungen und hohen Zähigkeitsanforderungen.

CVD-multilayer coating

Machining steel, stainless steel and cast steel, at medium to large chip-cross-sections and medium to low cutting speeds under unfavourable machining conditions where good toughness is required.

Rivestimento multistrato CVD

Lavorazione di acciaio inossidabile e acciaio da fusione per sezioni di taglio medie e grandi e velocità di taglio medie e basse. In condizioni di lavorazione non favorevoli quando è richiesta una buona tenacità.

AM350

CVD-Mehrlagenbeschichtung

Zur Bearbeitung von Stahl und Stahlguss mit hohen Schnittgeschwindigkeiten, mittleren bis hohen Spanquerschnitten und wechselnden Schnitttiefen. Verschleißfeste Sorte durch speziell aufeinander abgestimmtes Substrat und Beschichtung. Einsatz im Schlicht- und mittleren Schruppbereich.

CVD-multilayer coating

Grade with a good combination of wear resistance and toughness for turning steel, stainless steel as well as cast steel at medium chip-cross-sections and medium to high cutting speeds. Can also be used under unfavourable machining conditions. Special grade for stainless steel (austenitic). Apply in finishing and medium roughing applications.

Rivestimento multistrato CVD

Grado resistente all'usura, buona tenacità per la tornitura dell'acciaio, acciaio inossidabile, sezioni di taglio medie, velocità di taglio medie ed elevate, in condizioni di lavoro non favorevoli. Grado particolarmente adatto a acciai austenitici ed acciai inossidabili.

AM5035

PVD-Mehrlagenbeschichtung

Eine verbesserte PVD-Beschichtung auf einem zähen und verschleißfesten Hartmetallsubstrat. Mit einem höheren Kobaltgehalt verfügt diese Sorte über die nötige Zähigkeit, um den Ansprüchen beim Ein- und Abstechen gerecht zu werden. AM5035 ist ausgezeichnet für die Bearbeitung der meisten Stähle, nichtrostenden Stählen und schwer zerspanbaren Stählen.

PVD-multilayer coating

An improved PVD coating on a tough and wear resistant carbide grade. Due to the higher cobalt content this grade contains all the required toughness for part-off and grooving applications. AM5035 is excellent at machining most steel, stainless steel and hard to machine materials.

Rivestimento multiplo PVD

Un rivestimento PVD di ultima generazione, su base di metallo duro resistente all'usura e con una buona tenacità. Grazie all'elevato contenuto di cobalto, questa qualità ha la tenacità necessaria per la lavorazione di gole e per la tronatura. La qualità AM5035 è indicata per la lavorazione della maggior parte degli acciai, dell'acciaio inossidabile, della ghisa e di materiali difficili da lavorare.

AR17C

CVD-Mehrlagenbeschichtung

Bearbeitung von Grauguss, Gusseisen mit Kugelgraphit und Hartguss. Auch geeignet für rostfreien Stahl, Stahl und Stahlguss bei mittleren bis höchsten Schnittgeschwindigkeiten. Einsatz im Schlicht- und unteren Schruppbereich.

CVD-multilayer coating

For machining grey cast iron, cast iron with graphite and hard cast material. Also suitable for stainless steel, steel and cast steel at medium to high cutting speed. Apply in finishing and lighter roughing applications.

Rivestimento multistrato CVD

Lavorazione della ghisa, ghisa sferoidale, ghisa temperata, acciaio, fusioni d'acciaio a velocità di taglio medie, elevate e molto elevate; per finitura e tagli medi.

AR27C

CVD-Mehrlagenbeschichtung

Bearbeitung von Stahl, Stahlguss, rostfreiem Stahl, Gusseisen mit Kugelgraphit sowie Grauguss mit hohen Schnittgeschwindigkeiten unter stabilen Bearbeitungsbedingungen.

CVD-multilayer coating

Machining of steel, stainless steel, spheroidal cast iron, cast steel and grey cast iron at high cutting speeds under stable machining conditions.

Rivestimento multistrato CVD

Lavorazione dell'acciaio, acciaio inossidabile, ghisa sferoidale, fusioni d'acciaio a velocità di taglio elevate in condizioni di taglio stabili.

Beschichtet / Coated / Rivestito

AT10

PVD-Mehrlagenbeschichtung

Zur Bearbeitung von Aluminium und Aluminiumlegierungen, Kupfer, Bronze, NE-Metallen und hochschmelzenden Werkstoffen bei mittleren Spanquerschnitten und unter ungünstigen Bearbeitungsbedingungen. Auch geeignet für rostfreie Stähle.

PVD-multilayer coating

Grade for machining aluminium and aluminium-alloy, copper, brass, non-ferrous materials and refractory metals at medium cutting and under unfavourable cutting conditions. Also suitable for stainless steel.

Rivestimento multistrato PVD

Per lavorare l'alluminio e sue leghe, il rame, il bronzo, materiali non ferrosi, e metalli refrattari (per esempio Niobio, Tantalio, Molibdeno, Wolframio) per sezioni di taglio medie e in condizioni di taglio non favorevoli.

Unbeschichtet / Uncoated / Non rivestito

AK10

Feinkorn-Hartmetall zur Bearbeitung von Gusswerkstoffen, Leicht- und Buntmetallen, hochschmelzenden Metallen und gehärteten Stählen bis 55 HRC. In Verbindung mit der Spanleitstufengeometrie-ALU besonders für das Stechdrehen von Al und Cu-Legierungen zu empfehlen.

Submicron carbide grade for machining cast materials, light and non-ferrous materials, refractory metals, hardened steels up to 55 HRC. In connection with chipbreaker-ALU specially suitable for machining aluminium and copper alloys.

Metallo duro submicrograna per la lavorazione di fusioni, leghe leggere e non ferrose, metalli refrattari, metalli temprati fino a 55 HRC. Abbinato al rompitrucciolo-ALU è specificamente adatto per la lavorazione leghe di alluminio e rame.

CERMET

Bearbeitung von Stahl, Stählen mittlerer Festigkeit sowie rostfreiem Stahl und Gusseisen mit Kugelgraphit. Bedingt einsetzbar für Grauguss.

Machining of steel, steels with medium tensile strength as well as stainless steel and spheroidal cast iron. Limited use on grey cast iron.

Lavorazione dell'acciaio, acciai di durezza media come l'acciaio inossidabile e la ghisa sferoidale. Uso limitato sulla ghisa grigia.

AH7520 (CBN)

Bearbeitung von gehärteten Werkstoffen (sekundärharte Eisenwerkstoffe). Z. B.: Hartguss, gehärtete Stähle ab 50 HRC, Nihard und Stellite.

Machining of hardened materials (hardened steels). For example, hard cast iron, hardened steel from 50 HRC onwards, Nihard and stellite.

Lavorazione di materiali duri (acciai temprati). P.e.: ghisa temprata, acciaio temprato > 50 HRC, Nihard e stellite.

AN8020 (PKD)

Bearbeitung von NE-Metallen, Aluminiumlegierungen mit Siliziumanteilen, glas- und kohlefaserverstärkte Kunststoffe, Kugelgraphitguss bei hohen Schnittdaten. Durch die scharfe Schneidkante entstehen geringe Schnittdrücke und sehr gute Oberflächengüten bei extrem hoher Wärmeleitfähigkeit. Fein- und Feinstbearbeitung bei glattem und unterbrochenem Schnitt.

Machining of non-ferrous metals, aluminium alloys with silicon, glass- and coal-fiber reinforced materials, spheroidal cast iron, at high cutting speeds. Sharp cutting edges enable low cutting forces and extremely good surface finish. Finishing and super finishing even at interrupted cuts.

Lavorazione dei metalli non ferrosi, leghe d'alluminio con basso tenore di Silicio, materiali rinforzati al vetro e fibre di carbonio, a velocità di taglio elevate. Il tagliente affilato rende possibile bassi sforzi di taglio ed una finitura superficiale estremamente buona. Finitura e super finitura anche con taglio interrotto.

NC-Standard

Standardausführung / Standard geometry / Esecuzione standard

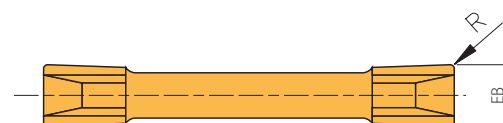
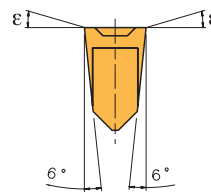
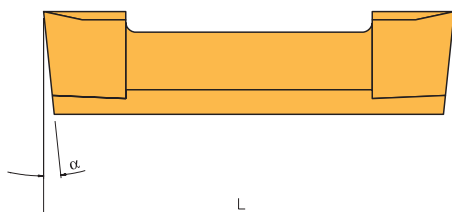

Präzisionsgeschliffene Ausführung / Precision ground execution / Esecuzione rettifica di precisione

							PG 15								
							beschichtet coated rivestito					unbeschichtet uncoated non rivestito	hochhart ultra-hard extra duri		
Bezeichnung Designation Articolo	EB ± 0,02	L ± 0,02	α	R	ε	Anwendung Application Applicazione	AM35C	AM350	AM5035	AR17C	AR27C	AK10	AH7520	AN8020	
21201	2	12	7/15°	0,1	12°	Außen und Innen External and internal Esterno ed interno	●	●	●	●	●	●		●	
21201FN	2	12	7/15°	0,1	0°									●	
21201TN	2	12	7/15°	0,1	0°									●	
21204	2	12	7/15°	0,4	12°		●		●						
31602	3	16	7/15°	0,2	12°		●	●	●	●	●		●		●
31602FN	3	16	7/15°	0,2	0°									●	
31602TN	3	16	7/15°	0,2	0°									●	
31604	3	16	7/15°	0,4	12°		●		●						
32002	3	20	6/16°	0,2	12°		●	●	●	●	●		●		●
32002FN	3	20	6/16°	0,2	0°									●	
32002TN	3	20	6/16°	0,2	0°									●	
32004	3	20	6/16°	0,4	12°		●		●						
42202	4	22	6/9,5°	0,2	12°		●	●	●	●	●		●		●
42202FN	4	22	6/9,5°	0,2	0°									●	
42202TN	4	22	6/9,5°	0,2	0°									●	
42204	4	22	6/9,5°	0,4	12°		●		●						
42210	4	22	6/9,5°	1,0	12°		●								
52502	5	25	6/8,5°	0,2	12°		●	●	●	●	●		●		●
52502FN	5	25	6/8,5°	0,2	0°									●	
52502TN	5	25	6/8,5°	0,2	0°									●	
52504	5	25	6/8,5°	0,4	12°	●		●							
63002	6	30	6°	0,2	12°	●	●	●	●	●		●		●	
63002FN	6	30	6°	0,2	0°								●		
63002TN	6	30	6°	0,2	0°								●		
63004	6	30	6°	0,4	12°	●		●							
63010	6	30	6°	1,0	12°	●									
83804	8	38	6°	0,4	12°	●	●	●	●	●		●		●	
83804FN	8	38	6°	0,4	0°								●		
83804TN	8	38	6°	0,4	0°								●		

NC-Standard

Präzisionsgeschliffene Ausführung / Precision ground execution / Esecuzione rettifica di precisione

							PG 15							
							beschichtet coated rivestito					unbeschichtet uncoated non rivestito	hochhart ultra-hard extra duri	
Bezeichnung Designation Articolo	EB ± 0,02	L ± 0,02	α	R	ε	Anwendung Application Applicazione	AM35C	AM350	AM5035	AR17C	AR27C	AK10	AH7520	AN8020
104604	10	46	6°	0,4	12°	Nur Außen	●	●	●	●		●		
104604FN	10	46	6°	0,4	0°	External only							●	
104604TN	10	46	6°	0,4	0°	Solo esterno							●	

ε = Spanwinkel
ε = Rake angle
ε = Angolo di taglio

Hinweis für AN8020 und AH7520: Einseitig bestückte Schneideinsätze mit einem Spanwinkel von 0°
Remark for AN8020 and AH7520 inserts: single-sided with a rake angle of 0°
Nota gli inserti AN8020 e AH7520 hanno un solo tagliente con un angolo di taglio di 0°

P	●	○	○	○	○									
M	○	●	●		○									
K									●	●		●		
N												●		●
S	○	○	○	○	○				○	○		○		○
H									○	○			●	

● Hauptanwendung
Main application
Applicazione principale
○ Nebenanwendung
Secondary application
Applicazione secondaria

3

NC-12

Kopierausführung / Copy-turning geometry / Geometria di copiatura

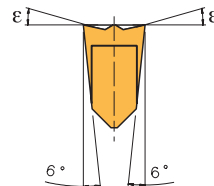
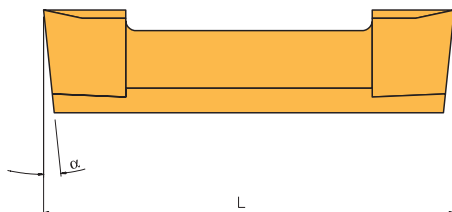

geschliffen
ground
rettificato

3

Präzisionsgeschliffene Ausführung / Precision ground execution / Esecuzione rettifica di precisione

							PG 15			
							beschichtet coated rivestito			unbeschichtet uncoated non rivestito
Bezeichnung Designation Articolo	EB ± 0,02	L ± 0,02	α	R	ε	Anwendung Application Applicazione	AM27C	AM35C	AM5035	CERMET
21201-12	2,0	12	7/15°	0,1	12°	Außen und Innen External and internal Esterno ed interno	●	●	●	●
21202-12	1,9	11	7/15°	0,2	12°		●	●	●	●
31602-12	3,0	16	7/15°	0,2	12°		●	●	●	●
31604-12	2,9	15	7/15°	0,4	12°		●	●	●	●
32002-12	3,0	20	6/16°	0,2	12°		●	●	●	●
32004-12	2,9	19	6/16°	0,4	12°		●	●	●	●
42202-12	4,0	22	6/9,5°	0,2	12°		●	●	●	●
52502-12	5,0	25	6/8,5°	0,2	12°		●	●	●	●
52504-12	4,9	24	6/8,5°	0,4	12°	●	●	●	●	
63002-12	6,0	30	6°	0,2	12°	Nur Außen External only Solo esterno	●	●	●	●
83804-12	8,0	38	6°	0,4	12°		●	●	●	●
104604-12	10,0	46	6°	0,4	12°		●	●	●	●

ε = Spanwinkel
ε = Rake angle
ε = Angolo di taglio

P	●	●	○	●
M	○	○	●	○
K				○
N				
S	○	○	○	
H				

● Hauptanwendung
Main application
Applicazione principale
○ Nebenanwendung
Secondary application
Applicazione secondaria

NC-AM

Kopierausführung / Copy-turning geometry / Geometria di copiatura

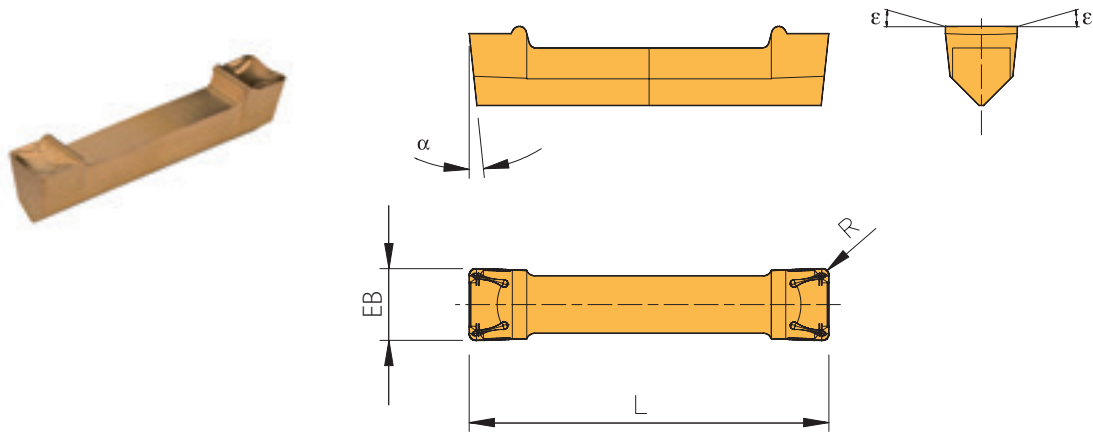

gesintert
sintered
sinterizzato

Gesinterte Ausführung / Sintered Execution / Esecuzione Sinterizzato

							PG 15	
							beschichtet coated rivestito	
Bezeichnung Designation Articolo	EB ± 0,05	L	α	R	ε	Anwendung Application Applicazione	AM27C	AM350
21202-AM	2,06	12	6/15°	0,2	6 / 20°	Außen und Innen External and internal Esterno ed interno	●	●
31602-AM	3,06	16	6/15°	0,2	6 / 20°		●	●
32002-AM	3,06	20	6/15°	0,2	6 / 20°		●	●
42204-AM	4,06	22	6/9,5°	0,4	6 / 20°	Nur Außen External only Solo esterno	●	●
52504-AM	5,06	25	6/8,5°	0,4	6 / 20°		●	●
63008-AM	6,06	30	6°	0,8	6 / 20°	Nur Außen External only Solo esterno	●	●
83808-AM	8,06	38	6°	0,8	6 / 20°		●	●
104608-AM	10,07	46	6°	0,8	6 / 20°		●	●

ε = Spanwinkel
ε = Rake angle
ε = Angolo di taglio

P	●	○
M	○	●
K		
N		
S	○	○
H		

● Hauptanwendung
Main application
Applicazione principale
○ Nebenanwendung
Secondary application
Applicazione secondaria

NC-V

Vollradiusausführung / Full radius execution / Esecuzione a raggio completo

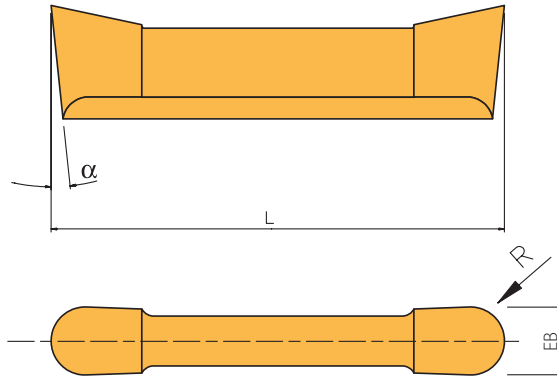

Präzisionsgeschliffene Ausführung / Precision ground execution / Esecuzione rettifica di precisione

3

Bezeichnung Designation Articolo	EB ± 0,02	L ± 0,02	α	R	ε	Anwendung Application Applicazione	PG 15				
							beschichtet coated rivestito	unbeschichtet uncoated non rivestito	hochhart ultra-hard extra duri		
							AM35C	AK10	AH7520	AN8020	
21210V	2	12	7/15°	1,0	12°	Außen und Innen External and internal Esterno ed interno	●	●		●	
21210V-FN	2	12	7/15°	1,0	0°					●	
21210V-TN	2	12	7/15°	1,0	0°					●	
31615V	3	16	7/15°	1,5	12°		●	●			●
31615V-FN	3	16	7/15°	1,5	0°					●	
31615V-TN	3	16	7/15°	1,5	0°					●	
32015V	3	20	6/16°	1,5	10°		●	●			●
32015V-FN	3	20	6/16°	1,5	0°					●	
32015V-TN	3	20	6/16°	1,5	0°					●	
42220V	4	22	6/9,5°	2,0	10°		●	●			●
42220V-FN	4	22	6/9,5°	2,0	0°					●	
42220V-TN	4	22	6/9,5°	2,0	0°					●	
52525V	5	25	6/8,5°	2,5	10°		●	●			●
52525V-FN	5	25	6/8,5°	2,5	0°					●	
52525V-TN	5	25	6/8,5°	2,5	0°					●	
63030V	6	30	6°	3,0	10°		●	●			●
63030V-FN	6	30	6°	3,0	0°					●	
63030V-TN	6	30	6°	3,0	0°					●	
83840V	8	38	6°	4,0	10°	●	●			●	
83840V-FN	8	38	6°	4,0	0°				●		
83840V-TN	8	38	6°	4,0	0°				●		
104650V	10	46	6°	5,0	10°	●	●			●	
104650V-FN	10	46	6°	5,0	0°				●		
104650V-TN	10	46	6°	5,0	0°				●		

Achtung: Beim Einsatz von Schneideinsätzen in Vollradiusausführung muss die Unterstüztplatte abgeändert werden.
Attention: The use of full radius inserts require a slightly modified support blade
Attenzione: l'utilizzo degli inserti a raggio completo rende necessaria una modifica della lama.

ε = Spanwinkel
ε = Rake angle
ε = Angolo di taglio

Hinweis für AN8020 und AH7520: Einseitig bestückte Schneideinsätze mit einem Spanwinkel von 0°
Remark for AN8020 and AH7520 inserts: single-sided with a rank angle of 0°
Nota gli inserti AN8020 e AH7520 hanno un solo tagliente con un angolo di taglio di 0°

P	●		
M	○		
K		●	
N		●	●
S	○	○	○
H			●

● Hauptanwendung
Main application
Applicazione principale
○ Nebenanwendung
Secondary application
Applicazione secondaria

NC-VK

Vollradiusausführung / Full radius execution / Esecuzione a raggio completo

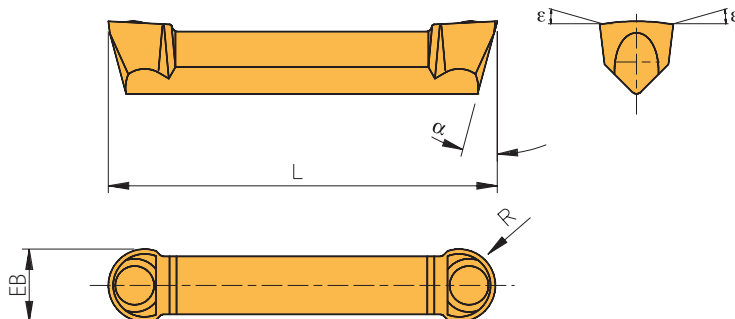

3

Präzisionsgeschliffene Ausführung / Precision ground execution / Esecuzione rettifica di precisione

							PG 15			
							beschichtet coated rivestito			unbeschichtet uncoated non rivestito
Bezeichnung Designation Articolo	EB ± 0,02	L ± 0,02	α	R	ε	Anwendung Application Applicazione	AM35C	AM5035	AT10	AK10
21210VK	2	12	7/15°	1,0	3°	Außen und Innen External and internal Esterno ed interno	●	●	●	●
31615VK	3	16	7/15°	1,5	3°		●	●	●	●
32015VK	3	20	6/16°	1,5	3°		●	●	●	●
42220VK	4	22	6/9,5°	2,0	3°		●	●	●	●
52525VK	5	25	6/8,5°	2,5	3°		●	●	●	●
63030VK	6	30	6°	3,0	3°		●	●	●	●
83840VK	8	38	6°	4,0	3°	Nur Außen External only Solo esterno	●	●	●	●
104650VK	10	46	6°	5,0	3°		●	●	●	●

Achtung: Beim Einsatz von Schneideinsätzen in Vollradiusausführung muss die Unterstützplatte abgeändert werden.
Attention: The use of full radius inserts require a slightly modified support blade
Attenzione: l'utilizzo degli inserti a raggio completo rende necessaria una modifica della lama.

ε = Spanwinkel
ε = Rake angle
ε = Angolo di taglio

Hinweis für AN8020 und AH7520: Einseitig bestückte Schneideinsätze mit einem Spanwinkel von 0°
Remark for AN8020 and AH7520 inserts: single-sided with a rank angle of 0°
Nota gli inserti AN8020 e AH7520 hanno un solo tagliente con un angolo di taglio di 0°

P	●	○		
M	○	●		
K			●	●
N			●	●
S	○	○	○	○
H				

● Hauptanwendung
Main application
Applicazione principale
○ Nebenanwendung
Secondary application
Applicazione secondaria

NC-ALU

Aluminiumausführung / Aluminium geometry / Geometria alluminio

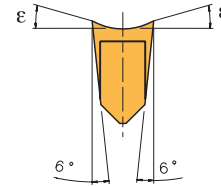
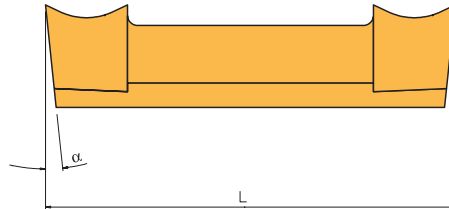

Präzisionsgeschliffene Ausführung / Precision ground execution / Esecuzione rettifica di precisione

							PG 15		
							beschichtet coated rivestito		unbeschichtet uncoated non rivestito
Bezeichnung Designation Articolo	EB ± 0,02	L ± 0,02	α	R	ε	Anwendung Application Applicazione	AM35C	AT10	AK10
21201-ALU	2	12	8/15°	0,1	25°	Außen und Innen External and internal Esterno ed interno		●	●
31602-ALU	3	16	8/15°	0,2	25°			●	●
32002-ALU	3	20	8/16°	0,2	25°			●	●
42202-ALU	4	22	8°	0,2	25°			●	●
52502-ALU	5	25	8°	0,2	25°			●	●
63002-ALU	6	30	8°	0,2	25°	Nur Außen External only Solo esterno	●	●	●
83804-ALU	8	38	8°	0,4	25°			●	●
104604-ALU	10	46	8°	0,4	25°			●	●

ε = Spanwinkel
ε = Rake angle
ε = Angolo di taglio

P	●		
M	○		
K		●	●
N		●	●
S	○	○	○
H			

● Hauptanwendung
Main application
Applicazione principale
○ Nebenanwendung
Secondary application
Applicazione secondaria

3

NC-DIN471

Ausführung für Sicherungsringeinstiche / Circlip inserts / Inserti per sedi seeger

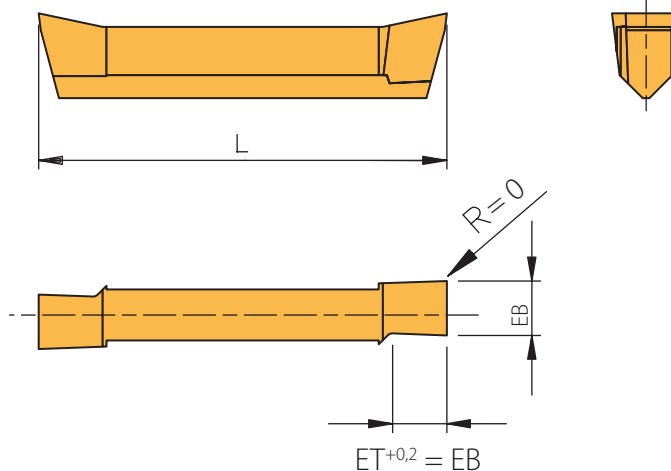

Rechte Ausführung abgebildet
Right-hand execution shown
Versione destra in figura

Präzisionsgeschliffene Ausführung / Precision ground execution / Esecuzione rettifica di precisione

					PG 15	
					beschichtet coated rivestito	unbeschichtet uncoated non rivestito
Bezeichnung Designation Articolo	EB ± 0,05	L ± 0,03	ε	Anwendung Application Applicazione	AM35C	AK10
2-04/471L/R	0,55	12	12°	Außen und Innen External and internal Esterno ed interno	●	●
2-06/471L/R	0,75	12	12°		●	●
2-07/471L/R	0,85	12	12°		●	●
2-08/471L/R	0,95	12	12°		●	●
2-10/471L/R	1,15	12	12°		●	●
2-12/471L/R	1,35	12	12°		●	●
2-15/471L/R	1,65	12	12°		●	●
2-175/471L/R	1,90	12	12°		●	●
3-04/471L/R	0,55	20	12°		●	●
3-06/471L/R	0,75	20	12°		●	●
3-07/471L/R	0,85	20	12°		●	●
3-08/471L/R	0,95	20	12°		●	●
3-10/471L/R	1,15	20	12°		●	●
3-12/471L/R	1,35	20	12°		●	●
3-15/471L/R	1,65	20	12°		●	●
3-175/471L/R	1,90	20	12°		●	●
3-20/471L/R	2,20	20	12°		●	●
3-25/471L/R	2,70	20	12°		●	●
3-30/471L/R	3,13	20	12°		●	●

NC-DIN471

Präzisionsgeschliffene Ausführung / Precision ground execution / Esecuzione rettifica di precisione

					PG 15	
					beschichtet coated rivestito	unbeschichtet uncoated non rivestito
Bezeichnung Designation Articolo	EB ± 0,05	L ± 0,03	ε	Anwendung Application Applicazione	AM35C	AK10
3M-04/471L/R	0,55	16	12°	Außen und Innen External and internal Esterno ed interno	●	
3M-06/471L/R	0,75	16	12°		●	
3M-07/471L/R	0,85	16	12°		●	
3M-08/471L/R	0,95	16	12°		●	
3M-10/471L/R	1,15	16	12°		●	
3M-12/471L/R	1,35	16	12°		●	
3M-15/471L/R	1,65	16	12°		●	
3M-175/471L/R	1,90	16	12°		●	
3M-20/471L/R	2,20	16	12°		●	
3M-25/471L/R	2,70	16	12°		●	
3M-30/471L/R	3,13	16	12°		●	

ε = Spanwinkel
ε = Rake angle
ε = Angolo di taglio

P	●	
M	○	
K		●
N		●
S	○	○
H		

● Hauptanwendung
Main application
Applicazione principale

○ Nebenanwendung
Secondary application
Applicazione secondaria

3

Artikel / Item / Articolo	PG 13
U-Platte / Support blade / Spina staffa	
10208 R/L	●
102-2530 R/L	●
102-3040 R/L	●
102-4050 R/L	●
102-5060 R/L	●
102-6075 R/L	●
102-75100 R/L	●
102-100150 R/L	●
102-150300 R/L	●
102-300500 R/L	●
10312 R/L	●
103-2530 R/L	●
103-3040 R/L	●
103-4050 R/L	●
103-5060 R/L	●
103-6075 R/L	●
103-75100 R/L	●
103-100150 R/L	●
103-150300 R/L	●
103-300500 R/L	●
20306 R/L	●
20310 R/L	●
203-5060 R/L	●
203-6075 R/L	●
203-75100 R/L	●
203-100150 R/L	●
203-150300 R/L	●
203-300500 R/L	●
203-500XX R/L	●
203S-5060 R/L Kontra	●
203S-6075 R/L Kontra	●
203S-75100 R/L Kontra	●
203S-100150 R/L Kontra	●
203S-150300 R/L Kontra	●
203S-300500 R/L Kontra	●
203S-500XX R/L Kontra	●
20408 R/L	●
20412 R/L	●
204-5060 R/L	●
204-6075 R/L	●
204-75100 R/L	●
204-100150 R/L	●
204-150300 R/L	●
204-300500 R/L	●
204-500XX R/L	●
204S-5060 R/L Kontra	●
204S-6075 R/L Kontra	●
204S-75100 R/L Kontra	●
204S-100150 R/L Kontra	●
204S-150300 R/L Kontra	●
204S-300500 R/L Kontra	●
204S-500XX R/L Kontra	●
20511 R/L	●
20515 R/L	●
205-5060 R/L	●
205-6075 R/L	●
205-75100 R/L	●
205-100150 R/L	●
205-150300 R/L	●
205-300500 R/L	●
205-500XX R/L	●
205S-5060 R/L Kontra	●
205S-6075 R/L Kontra	●
205S-75100 R/L Kontra	●
205S-100150 R/L Kontra	●
205S-150300 R/L Kontra	●
205S-300500 R/L Kontra	●
205S-500XX R/L Kontra	●
20620 R/L	●
206-5060 R/L	●
206-6075 R/L	●
206-75100 R/L	●
206-100150 R/L	●
206-150300 R/L	●
206-300500 R/L	●
206-500XX R/L	●
206S-5060 R/L Kontra	●
206S-6075 R/L Kontra	●

Artikel / Item / Articolo	PG 13
U-Platte / Support blade / Spina staffa	
206S-75100 R/L Kontra	●
206S-100150 R/L Kontra	●
206S-150300 R/L Kontra	●
206S-300500 R/L Kontra	●
206S-500XX R/L Kontra	●
30817 R/L	●
308-75100 R/L	●
308-100150 R/L	●
308-150300 R/L	●
308-300500 R/L	●
308-500XX R/L	●
308S-75100 R/L Kontra	●
308S-100150 R/L Kontra	●
308S-150300 R/L Kontra	●
308S-300500 R/L Kontra	●
308S-500XX R/L Kontra	●
31025 R/L	●
310-75100 R/L	●
310-100150 R/L	●
310-150300 R/L	●
310-300500 R/L	●
310-500XX R/L	●
310S-75100 R/L Kontra	●
310S-100150 R/L Kontra	●
310S-150300 R/L Kontra	●
310S-300500 R/L Kontra	●
310S-500XX R/L Kontra	●
9-20310 R/L	●
9-20412 R/L	●
9-20515 R/L	●
9-20620 R/L	●
9-UT 316 R/L	●
9-UT 419 R/L	●
9-UT 522 R/L	●
9-UT 627 R/L	●
UA2/471 R/L	●
UA3/471 R/L	●
UA471 R/L	●
UI 471 R/L	●
UT316 R/L	●
UT3-5060 R/L	●
UT3-6075 R/L	●
UT3-75100 R/L	●
UT3-100150 R/L	●
UT3-150300 R/L	●
UT3-300500 R/L	●
UT3-500XX R/L	●
UT3S-5060 R/L Kontra	●
UT3S-6075 R/L Kontra	●
UT3S-75100 R/L Kontra	●
UT3S-100150 R/L Kontra	●
UT3S-150300 R/L Kontra	●
UT3S-300500 R/L Kontra	●
UT3S-500XX R/L Kontra	●
UT419 R/L	●
UT4-5060 R/L	●
UT4-6075 R/L	●
UT4-75100 R/L	●
UT4-100150 R/L	●
UT4-150300 R/L	●
UT4-300500 R/L	●
UT4-500XX R/L	●
UT4S-5060 R/L Kontra	●
UT4S-6075 R/L Kontra	●
UT4S-75100 R/L Kontra	●
UT4S-100150 R/L Kontra	●
UT4S-150300 R/L Kontra	●
UT4S-300500 R/L Kontra	●
UT4S-500XX R/L Kontra	●
UT522 R/L	●
UT5-5060 R/L	●
UT5-6075 R/L	●
UT5-75100 R/L	●
UT5-100150 R/L	●
UT5-150300 R/L	●
UT5-300500 R/L	●
UT5-500XX R/L	●
UT5S-5060 R/L Kontra	●

Artikel / Item / Articolo	PG 13
U-Platte / Support blade / Spina staffa	
UT5S-6075 R/L Kontra	●
UT5S-75100 R/L Kontra	●
UT5S-100150 R/L Kontra	●
UT5S-150300 R/L Kontra	●
UT5S-300500 R/L Kontra	●
UT5S-500XX R/L Kontra	●
UT627 R/L	●
UT6-5060 R/L	●
UT6-6075 R/L	●
UT6-75100 R/L	●
UT6-100150 R/L	●
UT6-150300 R/L	●
UT6-300500 R/L	●
UT6-500XX R/L	●
UT6S-5060 R/L Kontra	●
UT6S-6075 R/L Kontra	●
UT6S-75100 R/L Kontra	●
UT6S-100150 R/L Kontra	●
UT6S-150300 R/L Kontra	●
UT6S-300500 R/L Kontra	●
UT6S-500XX R/L Kontra	●
UT832 R/L	●
UT8-75100 R/L	●
UT8-100150 R/L	●
UT8-150300 R/L	●
UT8-300500 R/L	●
UT8-500XX R/L	●
UT8S-75100 R/L Kontra	●
UT8S-100150 R/L Kontra	●
UT8S-150300 R/L Kontra	●
UT8S-300500 R/L Kontra	●
UT8S-500XX R/L Kontra	●
UT1040 R/L	●
UT10-75100 R/L	●
UT10-100150 R/L	●
UT10-150300 R/L	●
UT10-300500 R/L	●
UT10-500XX R/L	●
UT10S-75100 R/L Kontra	●
UT10S-100150 R/L Kontra	●
UT10S-150300 R/L Kontra	●
UT10S-300500 R/L Kontra	●
UT10S-500XX R/L Kontra	●

Artikel / Item / Articolo	PG 14
Klemme / Clamb / Staffa	
KA3 R/L	●
KA4 R/L	●
KA5 R/L	●
KA6 R/L	●
KA8 R/L	●
KA10 R/L	●
KAK8 R/L	●
KAK10 R/L	●
KAM2 R/L	●
KAM2 R/L Kontra	●
KAM3 R/L	●
KAM3 R/L Kontra	●
KAML3 R/L	●
KAS3 R/L Kontra	●
KAS4 R/L Kontra	●
KAS5 R/L Kontra	●
KAS6 R/L Kontra	●
KAS8 R/L Kontra	●
KAS10 R/L Kontra	●
KI2F R/L	●
KI3F R/L	●
KI3W R/L	●
KI4W R/L	●
KI5W R/L	●
KT3 R/L	●
KT4 R/L	●
KT5 R/L	●
KT6 R/L	●
KTM2 R/L Kontra	●
KTM3 R/L Kontra	●
KTS3 R/L Kontra	●
KTS4 R/L Kontra	●
KTS5 R/L Kontra	●
KTS6 R/L Kontra	●
KTS8 R/L Kontra	●
KTS10 R/L Kontra	●
MKI3F R/L	●

Artikel / Item / Articolo	PG 11
Kühlmitteldüse / Coolant jet / Ugello refrigerante	
KMD 0519	●
KMD 0830	●
KMD 0818	●

Artikel / Item / Articolo	PG 11
Schraube / Screw / Vite	
AS0018	●
AS0019	●
AS0020	●
M154	●
SS1111	●
T154	●
T205	●
T206	●

Artikel / Item / Articolo	PG 11
Schlüssel / Key / Chiave	
KS1111	●
T5120	●

Artikel / Item / Articolo	PG 11
Verschlussringl / Locking ring / Anello di tenuta	
KVR 16	●
KVR 20	●
KVR 25	●

Empfohlene Schnittwerte

Werkstoff- gruppe	Gliederung der Werkstoffhauptgruppen und Kennbuchstaben		Brinell-Härte	Zugfestigkeit (N/mm ²)	Zerspanungsgruppe	Schnittgeschwindigkeit V _c (m/min)			
						beschichtet			
						AM27C	AM35C	AM350	
P	Unlegierter Stahl	C ≤ 0,25 % geglüht	125	428	P1	140 - 195 - 250	120 - 135 - 150	140 - 165 - 190	
		C > 0,25 ... ≤ 0,55 % geglüht	190	639	P2	110 - 145 - 180	60 - 95 - 130	110 - 125 - 140	
		C > 0,25 ... ≤ 0,55 % vergütet	210	708	P3	100 - 125 - 150	70 - 85 - 100	90 - 100 - 110	
		C > 0,55 % geglüht	190	639	P4	110 - 145 - 180	60 - 95 - 130	110 - 125 - 140	
		C > 0,55 % vergütet	300	1013	P5	100 - 125 - 150	70 - 85 - 100	90 - 105 - 120	
		Automatenstahl (kurzspanend) geglüht	220	745	P6	110 - 145 - 180	60 - 95 - 130	110 - 130 - 150	
	Niedrig legierter Stahl	geglüht	175	591	P7	130 - 170 - 210	70 - 85 - 100	130 - 150 - 170	
		vergütet	300	1013	P8	120 - 135 - 150	70 - 85 - 100	100 - 125 - 150	
		vergütet	380	1282	P9	120 - 135 - 150	70 - 85 - 100	100 - 125 - 150	
		vergütet	430	1477	P10	100 - 125 - 150	60 - 75 - 90	90 - 105 - 120	
	Hochlegierter Stahl und hochlegierter Werkzeugstahl	geglüht	200	675	P11	120 - 130 - 140	60 - 70 - 80	90 - 120 - 150	
		gehärtet und angelassen	300	1013	P12	90 - 100 - 110	60 - 70 - 80	70 - 95 - 120	
		gehärtet und angelassen	400	1361	P13	90 - 100 - 110	60 - 70 - 80	70 - 95 - 120	
	Nichtrostender Stahl	ferritisch / martensitisch, geglüht	200	675	P14	140 - 180 - 220	90 - 105 - 120	110 - 140 - 170	
		martensitisch, vergütet	330	1114	P15	120 - 130 - 140	60 - 75 - 90	80 - 155 - 90	
M	Nichtrostender Stahl	austenitisch, abgeschreckt	200	675	M1	130 - 165 - 200	100 - 140 - 180	110 - 155 - 200	
		austenitisch, ausscheidungsgehärtet (PH)	300	1013	M2	80 - 105 - 130	80 - 115 - 150	80 - 100 - 120	
		austenitisch-ferritisch, Duplex	230	778	M3	65 - 80 - 100	50 - 70 - 90	60 - 80 - 100	
K	Temperguss	ferritisch	200	675	K1	-	-	-	
		perritisch	260	867	K2	-	-	-	
	Grauguss	niedrige Festigkeit	180	602	K3	-	-	-	
		hohe Festigkeit / austenitisch	245	825	K4	-	-	-	
	Gusseisen mit Kugelgraphit	ferritisch	155	518	K5	-	-	-	
		perritisch	265	885	K6	-	-	-	
	GGV (CGI)		200	675	K7	-	-	-	
N	Aluminium-Knetlegierungen	nicht aushärtbar	30	-	N1	-	-	-	
		aushärtbar, ausgehärtet	100	343	N2	-	-	-	
	Aluminium-Gusslegierungen	≤ 12 % Si, nicht aushärtbar	75	260	N3	-	-	-	
		≤ 12 % Si, aushärtbar, ausgehärtet	90	314	N4	-	-	-	
		> 12 % Si, nicht aushärtbar	130	447	N5	-	-	-	
	Magnesiumlegierungen		70	250	N6	-	-	-	
	Kupfer und Kupferlegierungen (Bronze / Messing)	unlegiert, Elektrolytkupfer	100	343	N7	-	-	-	
		Messing, Bronze, Rotguss	90	314	N8	-	-	-	
		Cu-Legierung, kurzspanend	110	382	N9	-	-	-	
		hochfest, Ampco	300	1013	N10	-	-	-	
Nichtmetallische Werkstoffe	Thermoplaste (ohne abrasive Füllstoffe)	-	-	N11	-	-	-		
	Duroplaste (ohne abrasive Füllstoffe)	-	-	N12	-	-	-		
	Kunststoff glasfaserverstärkt GFRP	-	-	N13	-	-	-		
	Kunststoff kohlefaserverstärkt CFRP	-	-	N14	-	-	-		
	Kunststoff aramidfaserverstärkt AFRP	-	-	N15	-	-	-		
	Graphit (technisch)	80 Shore	-	N16	-	-	-		
S	Warmfeste Legierungen	Fe-Basis geglüht	200	675	S1	30 - 40 - 50	-	-	
		ausgehärtet	280	943	S2	25 - 35 - 40	20 - 30 - 40	20 - 30 - 40	
		geglüht	250	839	S3	10 - 20 - 30	20 - 25 - 30	20 - 25 - 30	
		Ni- oder Co-Basis ausgehärtet	350	1177	S4	10 - 15 - 20	-	-	
		gegossen	320	1076	S5	10 - 15 - 20	-	-	
	Titanlegierungen	Reintitan	200	675	S6	-	-	-	
		α- und β-Legierungen, ausgehärtet	375	1262	S7	-	-	-	
		β-Legierungen	410	1396	S8	-	-	-	
	Wolframlegierungen		300	1013	S9	-	-	-	
	Molybdänlegierungen		300	1013	S10	-	-	-	
H	Gehärteter Stahl	gehärtet und angelassen	50 HRC	-	H1	-	-	-	
		gehärtet und angelassen	55 HRC	-	H2	-	-	-	
		gehärtet und angelassen	60 HRC	-	H3	-	-	-	
	Gehärtetes Gusseisen	gehärtet und angelassen	55 HRC	-	H4	-	-	-	

Die Tabellenwerte sind Richtwerte.
Es kann notwendig sein, die Werte den jeweiligen Bearbeitungsumständen anzupassen.

					unbeschichtet		hochhart	
	AM5035	AR17C	AR27C	AT10	AK10	CERMET	AH7520	AN8020
	140 - 165 - 190	150 - 195 - 240	160 - 205 - 250	-	-	130 - 265 - 400	-	-
	110 - 125 - 145	110 - 140 - 170	120 - 155 - 190	-	-	100 - 215 - 325	-	-
	90 - 105 - 120	90 - 125 - 160	100 - 115 - 130	-	-	80 - 180 - 275	-	-
	110 - 125 - 140	110 - 140 - 170	120 - 155 - 190	-	-	100 - 215 - 325	-	-
	90 - 105 - 120	90 - 125 - 160	100 - 115 - 130	-	-	80 - 180 - 275	-	-
	110 - 125 - 140	110 - 140 - 170	120 - 155 - 190	-	-	100 - 215 - 325	-	-
	130 - 150 - 170	100 - 130 - 160	150 - 180 - 210	-	-	100 - 175 - 250	-	-
	100 - 125 - 150	80 - 105 - 150	130 - 150 - 170	-	-	90 - 195 - 300	-	-
	100 - 125 - 150	80 - 105 - 150	130 - 150 - 170	-	-	90 - 195 - 300	-	-
	90 - 105 - 120	70 - 95 - 120	100 - 125 - 150	-	-	60 - 105 - 150	-	-
	90 - 115 - 140	90 - 110 - 130	140 - 150 - 160	-	-	80 - 130 - 180	-	-
	70 - 95 - 120	70 - 90 - 110	90 - 110 - 130	-	-	60 - 100 - 140	-	-
	70 - 95 - 120	70 - 90 - 110	90 - 110 - 130	-	-	60 - 100 - 140	-	-
	110 - 140 - 170	110 - 135 - 160	140 - 180 - 220	-	-	80 - 150 - 220	-	-
	60 - 75 - 90	90 - 115 - 140	60 - 80 - 100	-	-	70 - 125 - 180	-	-
	110 - 155 - 200	-	130 - 165 - 200	-	-	100 - 175 - 250	-	-
	80 - 100 - 120	-	80 - 105 - 130	-	-	80 - 130 - 180	-	-
	60 - 80 - 100	-	65 - 80 - 100	-	-	60 - 105 - 150	-	-
	-	150 - 180 - 210	150 - 180 - 210	120 - 185 - 250	120 - 130 - 140	250 - 300 - 350	-	-
	-	120 - 160 - 200	120 - 160 - 200	100 - 150 - 200	90 - 110 - 130	160 - 190 - 250	-	-
	-	130 - 175 - 220	130 - 175 - 220	140 - 170 - 200	120 - 140 - 160	-	-	-
	-	100 - 130 - 160	100 - 130 - 160	120 - 145 - 170	120 - 135 - 150	-	-	-
	-	160 - 195 - 230	160 - 195 - 230	110 - 145 - 180	160 - 180 - 200	220 - 260 - 300	-	-
	-	120 - 145 - 170	120 - 145 - 170	120 - 170 - 220	100 - 120 - 140	180 - 205 - 230	-	-
	-	150 - 180 - 210	150 - 180 - 210	120 - 185 - 250	120 - 130 - 140	250 - 300 - 350	-	-
	-	-	-	120 - 535 - 950	100 - 450 - 800	-	-	-
	-	-	-	100 - 525 - 950	80 - 440 - 800	-	-	350 - 1675 - 3000
	-	-	-	100 - 350 - 600	80 - 290 - 500	-	-	350 - 1675 - 3000
	-	-	-	-	-	-	-	350 - 1675 - 3000
	-	-	-	-	-	-	-	350 - 1675 - 3000
	-	-	-	-	-	-	-	-
	-	-	-	150 - 250 - 350	130 - 215 - 300	-	-	600 - 900 - 1200
	-	-	-	250 - 425 - 600	200 - 350 - 500	-	-	600 - 900 - 1200
	-	-	-	150 - 250 - 350	130 - 215 - 300	-	-	600 - 900 - 1200
	-	-	-	-	-	-	-	-
	-	-	-	120 - 360 - 600	100 - 300 - 500	-	-	600 - 900 - 1200
	-	-	-	120 - 360 - 600	100 - 300 - 500	-	-	600 - 900 - 1200
	-	-	-	100 - 140 - 180	80 - 105 - 150	-	-	80 - 790 - 1500
	-	-	-	100 - 140 - 180	80 - 105 - 150	-	-	80 - 790 - 1500
	-	-	-	100 - 140 - 180	80 - 105 - 150	-	-	80 - 790 - 1500
	-	-	-	-	-	-	-	-
	-	30 - 40 - 50	25 - 35 - 45	-	-	-	-	-
	20 - 30 - 40	25 - 30 - 35	20 - 30 - 40	-	-	-	-	-
	20 - 25 - 30	15 - 20 - 25	15 - 20 - 25	-	-	-	-	-
	-	10 - 20 - 25	10 - 15 - 20	-	-	-	-	-
	-	10 - 15 - 20	10 - 15 - 20	-	-	-	-	-
	-	100 - 125 - 150	-	100 - 125 - 150	80 - 105 - 130	-	-	60 - 70 - 80
	-	40 - 50 - 60	-	50 - 65 - 80	40 - 55 - 70	-	-	50 - 60 - 70
	-	35 - 45 - 55	-	45 - 60 - 75	35 - 50 - 65	-	-	45 - 55 - 65
	-	-	-	-	-	-	-	-
	-	-	-	-	-	-	-	-
	-	-	-	-	-	-	-	-
	-	35 - 40 - 45	10 - 15 - 20	-	-	-	-	-
	-	-	-	-	-	-	80 - 140 - 200	-
	-	35 - 40 - 45	10 - 15 - 20	-	-	-	80 - 140 - 200	-

Recommended cutting data

Material group	Structure of the material groups and identification letters		Brinell hardness HB	Tensile strength Rm (N/mm ²)	Chipping group	Cutting speed V _c (m/min)			
						coated			
						AM27C	AM35C	AM350	
P	Unalloyed steel	C ≤ 0.25 % annealed	125	428	P1	140 - 195 - 250	120 - 135 - 150	140 - 165 - 190	
		C > 0.25 ... ≤ 0.55 % annealed	190	639	P2	110 - 145 - 180	60 - 95 - 130	110 - 125 - 140	
		C > 0.25 ... ≤ 0.55 % hardened and tempered	210	708	P3	100 - 125 - 150	70 - 85 - 100	90 - 100 - 110	
		C > 0.55 % annealed	190	639	P4	110 - 145 - 180	60 - 95 - 130	110 - 125 - 140	
		C > 0.55 % hardened and tempered	300	1013	P5	100 - 125 - 150	70 - 85 - 100	90 - 105 - 120	
		Machining steel (short-chipping) tempered	220	745	P6	110 - 145 - 180	60 - 95 - 130	110 - 130 - 150	
	Low alloyed steel	annealed	175	591	P7	130 - 170 - 210	70 - 85 - 100	130 - 150 - 170	
		hardened and tempered	300	1013	P8	120 - 135 - 150	70 - 85 - 100	100 - 125 - 150	
		hardened and tempered	380	1282	P9	120 - 135 - 150	70 - 85 - 100	100 - 125 - 150	
		hardened and tempered	430	1477	P10	100 - 125 - 150	60 - 75 - 90	90 - 105 - 120	
	High alloyed steel and high alloyed tool steel	annealed	200	675	P11	120 - 130 - 140	60 - 70 - 80	90 - 120 - 150	
		hardened	300	1013	P12	90 - 100 - 110	60 - 70 - 80	70 - 95 - 120	
		hardened	400	1361	P13	90 - 100 - 110	60 - 70 - 80	70 - 95 - 120	
	Stainless steel	ferritic / martensitic, annealed	200	675	P14	140 - 180 - 220	90 - 105 - 120	110 - 140 - 170	
		martensitic, hardened and tempered	330	1114	P15	120 - 130 - 140	60 - 75 - 90	80 - 75 - 90	
M	Stainless steel	austenitic, chilled	200	675	M1	130 - 165 - 200	100 - 140 - 180	110 - 155 - 200	
		austenitic, precipitation-hardened (PH)	300	1013	M2	80 - 105 - 130	80 - 115 - 150	80 - 100 - 120	
		austenitic-ferritic, Duplex	230	778	M3	65 - 80 - 100	50 - 70 - 90	60 - 80 - 100	
K	Malleable cast iron	ferritic	200	675	K1	-	-	-	
		pearlitic	260	867	K2	-	-	-	
	Cast iron	low tensile strength	180	602	K3	-	-	-	
		high tensile strength / austenitic	245	825	K4	-	-	-	
	Cast iron with nodular graphite	ferritic	155	518	K5	-	-	-	
		pearlitic	265	885	K6	-	-	-	
GGV (CGI)		200	675	K7	-	-	-		
N	Aluminium alloys long chipping	not heat treatable	30	-	N1	-	-	-	
		heat treatable, heat treated	100	343	N2	-	-	-	
		≤ 12 % Si, not heat treatable	75	260	N3	-	-	-	
	Casted aluminium alloys	≤ 12 % Si, aushärtbar, ausgehärtet	90	314	N4	-	-	-	
		> 12 % Si, not heat treatable	130	447	N5	-	-	-	
	Magnesium alloys		70	250	N6	-	-	-	
	Copper and copper alloys (Brass / Bronze)	Unalloyed, elektrolyte copper	100	343	N7	-	-	-	
		Brass, Bronze	90	314	N8	-	-	-	
		Cu-alloys, short-chipping	110	382	N9	-	-	-	
		High-tensile, Ampco	300	1013	N10	-	-	-	
Non-ferrous materials	Lead alloys (without abrasive filling material)	-	-	N11	-	-	-		
	Duroplastic (without abrasive filling material)	-	-	N12	-	-	-		
	Plastic glas fibre reinforced GFRP	-	-	N13	-	-	-		
	Plastic carbon fibre reinforced CFRP	-	-	N14	-	-	-		
	Plastic aramid fibre reinforced AFRP	-	-	N15	-	-	-		
	Graphite (tech.)		80 Shore	-	N16	-	-	-	
S	High temperature resistant alloys	Fe-Basis	annealed	200	675	S1	30 - 40 - 50	-	-
			heat treated	280	943	S2	25 - 35 - 40	20 - 30 - 40	20 - 30 - 40
		Ni- or Co-alloyed	annealed	250	839	S3	10 - 20 - 30	20 - 25 - 30	20 - 25 - 30
			heat treated	350	1177	S4	10 - 15 - 20	-	-
			casting	320	1076	S5	10 - 15 - 20	-	-
	Titanium alloys	Pure titan	200	675	S6	-	-	-	
		α- and β-alloys, heat treated	375	1262	S7	-	-	-	
		β-alloys	410	1396	S8	-	-	-	
	Wolfram alloys		300	1013	S9	-	-	-	
	Molybdän alloys		300	1013	S10	-	-	-	
H	Hardened steel	hardened	50 HRC	-	H1	-	-	-	
		hardened	55 HRC	-	H2	-	-	-	
		hardened	60 HRC	-	H3	-	-	-	
	Hardened cast iron	hardened	55 HRC	-	H4	-	-	-	

The recommended cutting data are only approximate values. It may be necessary to adjust them to each individual machining application.

					uncoated		untra-hard	
	AM5035	AR17C	AR27C	AT10	AK10	CERMET	AH7520	AN8020
	140 - 165 - 190	150 - 195 - 240	160 - 205 - 250	-	-	130 - 265 - 400	-	-
	110 - 125 - 145	110 - 140 - 170	120 - 155 - 190	-	-	100 - 215 - 325	-	-
	90 - 105 - 120	90 - 125 - 160	100 - 115 - 130	-	-	80 - 180 - 275	-	-
	110 - 125 - 140	110 - 140 - 170	120 - 155 - 190	-	-	100 - 215 - 325	-	-
	90 - 105 - 120	90 - 125 - 160	100 - 115 - 130	-	-	80 - 180 - 275	-	-
	110 - 125 - 140	110 - 140 - 170	120 - 155 - 190	-	-	100 - 215 - 325	-	-
	130 - 150 - 170	100 - 130 - 160	150 - 180 - 210	-	-	100 - 175 - 250	-	-
	100 - 125 - 150	80 - 105 - 150	130 - 150 - 170	-	-	90 - 195 - 300	-	-
	100 - 125 - 150	80 - 105 - 150	130 - 150 - 170	-	-	90 - 195 - 300	-	-
	90 - 105 - 120	70 - 95 - 120	100 - 125 - 150	-	-	60 - 105 - 150	-	-
	90 - 115 - 140	90 - 110 - 130	140 - 150 - 160	-	-	80 - 130 - 180	-	-
	70 - 95 - 120	70 - 90 - 110	90 - 110 - 130	-	-	60 - 100 - 140	-	-
	70 - 95 - 120	70 - 90 - 110	90 - 110 - 130	-	-	60 - 100 - 140	-	-
	110 - 140 - 170	110 - 135 - 160	140 - 180 - 220	-	-	80 - 150 - 220	-	-
	60 - 75 - 90	90 - 115 - 140	60 - 80 - 100	-	-	70 - 125 - 180	-	-
	110 - 155 - 200	-	130 - 165 - 200	-	-	100 - 175 - 250	-	-
	80 - 100 - 120	-	80 - 105 - 130	-	-	80 - 130 - 180	-	-
	60 - 80 - 100	-	65 - 80 - 100	-	-	60 - 105 - 150	-	-
	-	150 - 180 - 210	150 - 180 - 210	120 - 185 - 250	120 - 130 - 140	250 - 300 - 350	-	-
	-	120 - 160 - 200	120 - 160 - 200	100 - 150 - 200	90 - 110 - 130	160 - 190 - 250	-	-
	-	130 - 175 - 220	130 - 175 - 220	140 - 170 - 200	120 - 140 - 160	-	-	-
	-	100 - 130 - 160	100 - 130 - 160	120 - 145 - 170	120 - 135 - 150	-	-	-
	-	160 - 195 - 230	160 - 195 - 230	110 - 145 - 180	160 - 180 - 200	220 - 260 - 300	-	-
	-	120 - 145 - 170	120 - 145 - 170	120 - 170 - 220	100 - 120 - 140	180 - 205 - 230	-	-
	-	150 - 180 - 210	150 - 180 - 210	120 - 185 - 250	120 - 130 - 140	250 - 300 - 350	-	-
	-	-	-	120 - 535 - 950	100 - 450 - 800	-	-	-
	-	-	-	100 - 525 - 950	80 - 440 - 800	-	-	350 - 1675 - 3000
	-	-	-	100 - 350 - 600	80 - 290 - 500	-	-	350 - 1675 - 3000
	-	-	-	-	-	-	-	350 - 1675 - 3000
	-	-	-	-	-	-	-	350 - 1675 - 3000
	-	-	-	-	-	-	-	-
	-	-	-	150 - 250 - 350	130 - 215 - 300	-	-	600 - 900 - 1200
	-	-	-	250 - 425 - 600	200 - 350 - 500	-	-	600 - 900 - 1200
	-	-	-	150 - 250 - 350	130 - 215 - 300	-	-	600 - 900 - 1200
	-	-	-	-	-	-	-	-
	-	-	-	120 - 360 - 600	100 - 300 - 500	-	-	600 - 900 - 1200
	-	-	-	120 - 360 - 600	100 - 300 - 500	-	-	600 - 900 - 1200
	-	-	-	100 - 140 - 180	80 - 105 - 150	-	-	80 - 790 - 1500
	-	-	-	100 - 140 - 180	80 - 105 - 150	-	-	80 - 790 - 1500
	-	-	-	100 - 140 - 180	80 - 105 - 150	-	-	80 - 790 - 1500
	-	-	-	-	-	-	-	-
	-	30 - 40 - 50	25 - 35 - 45	-	-	-	-	-
	20 - 30 - 40	25 - 30 - 35	20 - 30 - 40	-	-	-	-	-
	20 - 25 - 30	15 - 20 - 25	15 - 20 - 25	-	-	-	-	-
	-	10 - 20 - 25	10 - 15 - 20	-	-	-	-	-
	-	10 - 15 - 20	10 - 15 - 20	-	-	-	-	-
	-	100 - 125 - 150	-	100 - 125 - 150	80 - 105 - 130	-	-	60 - 70 - 80
	-	40 - 50 - 60	-	50 - 65 - 80	40 - 55 - 70	-	-	50 - 60 - 70
	-	35 - 45 - 55	-	45 - 60 - 75	35 - 50 - 65	-	-	45 - 55 - 65
	-	-	-	-	-	-	-	-
	-	-	-	-	-	-	-	-
	-	-	-	-	-	-	-	-
	-	35 - 40 - 45	10 - 15 - 20	-	-	-	-	-
	-	-	-	-	-	-	80 - 140 - 200	-
	-	35 - 40 - 45	10 - 15 - 20	-	-	-	80 - 140 - 200	-



Parametri di taglio suggeriti

Gruppo materiale	Struttura dei gruppi di materiali e lettere di riferimento		Durezza Brinell	Resistenza Rm (N/mm ²)	Gruppo di lavoro	Velocità di taglio V _c (m/min)			
						rivestito			
						AM27C	AM35C	AM350	
P	Acciai non legato	C ≤ 0,25 % ricotto	125	428	P1	140 - 195 - 250	120 - 135 - 150	140 - 165 - 190	
		C > 0,25 ... ≤ 0,55 % ricotto	190	639	P2	110 - 145 - 180	60 - 95 - 130	110 - 125 - 140	
		C > 0,25 ... ≤ 0,55 % bonificato	210	708	P3	100 - 125 - 150	70 - 85 - 100	90 - 100 - 110	
		C > 0,55 % ricotto	190	639	P4	110 - 145 - 180	60 - 95 - 130	110 - 125 - 140	
		C > 0,55 % bonificato	300	1013	P5	100 - 125 - 150	70 - 85 - 100	90 - 105 - 120	
	Acciai debolmente legati	Acciaio (truciolo corto) ricotto	220	745	P6	110 - 145 - 180	60 - 95 - 130	110 - 130 - 150	
		ricotto	175	591	P7	130 - 170 - 210	70 - 85 - 100	130 - 150 - 170	
		bonificato	300	1013	P8	120 - 135 - 150	70 - 85 - 100	100 - 125 - 150	
		bonificato	380	1282	P9	120 - 135 - 150	70 - 85 - 100	100 - 125 - 150	
		bonificato	430	1477	P10	100 - 125 - 150	60 - 75 - 90	90 - 105 - 120	
	Acciai fortemente legati e acciai da utensili	ricotto	200	675	P11	120 - 130 - 140	60 - 70 - 80	90 - 120 - 150	
		temprato e rinvenuto	300	1013	P12	90 - 100 - 110	60 - 70 - 80	70 - 95 - 120	
		temprato e rinvenuto	400	1361	P13	90 - 100 - 110	60 - 70 - 80	70 - 95 - 120	
	Acciai inossidabili	ferritico / martensitico, ricotto	200	675	P14	140 - 180 - 220	90 - 105 - 120	110 - 140 - 170	
		martensitico, bonificato	330	1114	P15	120 - 130 - 140	60 - 75 - 90	80 - 140 - 90	
M	Acciai inossidabili	austenitico, trattato o temperato	200	675	M1	130 - 165 - 200	100 - 140 - 180	110 - 155 - 200	
		austenitico, indurimento per precipitazione (PH)	300	1013	M2	80 - 105 - 130	80 - 115 - 150	80 - 100 - 120	
		austenitico-ferritico, Duplex	230	778	M3	65 - 80 - 100	50 - 70 - 90	60 - 80 - 100	
K	Ghisa temprata	ferritico	200	675	K1	-	-	-	
		perlitica	260	867	K2	-	-	-	
	Ghisa grigia	bassa resistenza	180	602	K3	-	-	-	
		alta resistenza / austenitico	245	825	K4	-	-	-	
	Ghisa sferoidale	ferritico	155	518	K5	-	-	-	
		perlitica	265	885	K6	-	-	-	
GGV (CGI)		200	675	K7	-	-	-		
N	Leghe di Alluminio stampato	non invecchiato	30	-	N1	-	-	-	
		rinvenuto, invecchiato	100	343	N2	-	-	-	
	Leghe di Alluminio da fusione	≤ 12 % Si, non invecchiato	75	260	N3	-	-	-	
		≤ 12 % Si, rinvenuto, invecchiato	90	314	N4	-	-	-	
		> 12 % Si, non invecchiato	130	447	N5	-	-	-	
	Leghe di magnesio		70	250	N6	-	-	-	
	Rame e Leghe di Rame (Bronzo / Ottone)	Non legati, Rame Elettrolitico	100	343	N7	-	-	-	
		Ottone, Bronzo	90	314	N8	-	-	-	
		Leghe Cu, truciolo corto	110	382	N9	-	-	-	
		Alta resistenza, Ampco	300	1013	N10	-	-	-	
Materiali non metallici	Leghe al piombo (senza materiale di riempimento abrasivo)	-	-	N11	-	-	-		
	Duroplastico (senza materiale di riempimento abrasivo)	-	-	N12	-	-	-		
	Plastica rinforzata in fibra di vetro GFRP	-	-	N13	-	-	-		
	Plastica rinforzata in fibra di carbonio CFRP	-	-	N14	-	-	-		
	Plastica rinforzata in fibra aramidica AFRP	-	-	N15	-	-	-		
	Grafite (tecnico)		80 Shore	-	N16	-	-	-	
S	Leghe resistenti al calore	Base-Fe ricotto	200	675	S1	30 - 40 - 50	-	-	
		Base-Fe invecchiato	280	943	S2	25 - 35 - 40	20 - 30 - 40	20 - 30 - 40	
		Base Ni o Co ricotto	250	839	S3	10 - 20 - 30	20 - 25 - 30	20 - 25 - 30	
		Base Ni o Co invecchiato	350	1177	S4	10 - 15 - 20	-	-	
		Base Ni o Co da fusione	320	1076	S5	10 - 15 - 20	-	-	
	Leghe di Titanio	Titanio puro	200	675	S6	-	-	-	
		Leghe α e β, invecchiato	375	1262	S7	-	-	-	
		Leghe β	410	1396	S8	-	-	-	
	Leghe di tungsteno		300	1013	S9	-	-	-	
	Leghe di molibdeno		300	1013	S10	-	-	-	
H	Acciaio Temprato	temprato e rinvenuto	50 HRC	-	H1	-	-	-	
		temprato e rinvenuto	55 HRC	-	H2	-	-	-	
		temprato e rinvenuto	60 HRC	-	H3	-	-	-	
	Ghisa Temprata	temprato e rinvenuto	55 HRC	-	H4	-	-	-	

I dati indicati in tabella sono valori approssimati.
Può essere necessario adattarli alle singole applicazioni di lavorazione.

					non rivestito		extra duri	
	AM5035	AR17C	AR27C	AT10	AK10	CERMET	AH7520	AN8020
	140 - 165 - 190	150 - 195 - 240	160 - 205 - 250	-	-	130 - 265 - 400	-	-
	110 - 125 - 145	110 - 140 - 170	120 - 155 - 190	-	-	100 - 215 - 325	-	-
	90 - 105 - 120	90 - 125 - 160	100 - 115 - 130	-	-	80 - 180 - 275	-	-
	110 - 125 - 140	110 - 140 - 170	120 - 155 - 190	-	-	100 - 215 - 325	-	-
	90 - 105 - 120	90 - 125 - 160	100 - 115 - 130	-	-	80 - 180 - 275	-	-
	110 - 125 - 140	110 - 140 - 170	120 - 155 - 190	-	-	100 - 215 - 325	-	-
	130 - 150 - 170	100 - 130 - 160	150 - 180 - 210	-	-	100 - 175 - 250	-	-
	100 - 125 - 150	80 - 105 - 150	130 - 150 - 170	-	-	90 - 195 - 300	-	-
	100 - 125 - 150	80 - 105 - 150	130 - 150 - 170	-	-	90 - 195 - 300	-	-
	90 - 105 - 120	70 - 95 - 120	100 - 125 - 150	-	-	60 - 105 - 150	-	-
	90 - 115 - 140	90 - 110 - 130	140 - 150 - 160	-	-	80 - 130 - 180	-	-
	70 - 95 - 120	70 - 90 - 110	90 - 110 - 130	-	-	60 - 100 - 140	-	-
	70 - 95 - 120	70 - 90 - 110	90 - 110 - 130	-	-	60 - 100 - 140	-	-
	110 - 140 - 170	110 - 135 - 160	140 - 180 - 220	-	-	80 - 150 - 220	-	-
	60 - 75 - 90	90 - 115 - 140	60 - 80 - 100	-	-	70 - 125 - 180	-	-
	110 - 155 - 200	-	130 - 165 - 200	-	-	100 - 175 - 250	-	-
	80 - 100 - 120	-	80 - 105 - 130	-	-	80 - 130 - 180	-	-
	60 - 80 - 100	-	65 - 80 - 100	-	-	60 - 105 - 150	-	-
	-	150 - 180 - 210	150 - 180 - 210	120 - 185 - 250	120 - 130 - 140	250 - 300 - 350	-	-
	-	120 - 160 - 200	120 - 160 - 200	100 - 150 - 200	90 - 110 - 130	160 - 190 - 250	-	-
	-	130 - 175 - 220	130 - 175 - 220	140 - 170 - 200	120 - 140 - 160	-	-	-
	-	100 - 130 - 160	100 - 130 - 160	120 - 145 - 170	120 - 135 - 150	-	-	-
	-	160 - 195 - 230	160 - 195 - 230	110 - 145 - 180	160 - 180 - 200	220 - 260 - 300	-	-
	-	120 - 145 - 170	120 - 145 - 170	120 - 170 - 220	100 - 120 - 140	180 - 205 - 230	-	-
	-	150 - 180 - 210	150 - 180 - 210	120 - 185 - 250	120 - 130 - 140	250 - 300 - 350	-	-
	-	-	-	120 - 535 - 950	100 - 450 - 800	-	-	-
	-	-	-	100 - 525 - 950	80 - 440 - 800	-	-	350 - 1675 - 3000
	-	-	-	100 - 350 - 600	80 - 290 - 500	-	-	350 - 1675 - 3000
	-	-	-	-	-	-	-	350 - 1675 - 3000
	-	-	-	-	-	-	-	350 - 1675 - 3000
	-	-	-	-	-	-	-	-
	-	-	-	150 - 250 - 350	130 - 215 - 300	-	-	600 - 900 - 1200
	-	-	-	250 - 425 - 600	200 - 350 - 500	-	-	600 - 900 - 1200
	-	-	-	150 - 250 - 350	130 - 215 - 300	-	-	600 - 900 - 1200
	-	-	-	-	-	-	-	-
	-	-	-	120 - 360 - 600	100 - 300 - 500	-	-	600 - 900 - 1200
	-	-	-	120 - 360 - 600	100 - 300 - 500	-	-	600 - 900 - 1200
	-	-	-	100 - 140 - 180	80 - 105 - 150	-	-	80 - 790 - 1500
	-	-	-	100 - 140 - 180	80 - 105 - 150	-	-	80 - 790 - 1500
	-	-	-	100 - 140 - 180	80 - 105 - 150	-	-	80 - 790 - 1500
	-	-	-	-	-	-	-	-
	-	30 - 40 - 50	25 - 35 - 45	-	-	-	-	-
	20 - 30 - 40	25 - 30 - 35	20 - 30 - 40	-	-	-	-	-
	20 - 25 - 30	15 - 20 - 25	15 - 20 - 25	-	-	-	-	-
	-	10 - 20 - 25	10 - 15 - 20	-	-	-	-	-
	-	10 - 15 - 20	10 - 15 - 20	-	-	-	-	-
	-	100 - 125 - 150	-	100 - 125 - 150	80 - 105 - 130	-	-	60 - 70 - 80
	-	40 - 50 - 60	-	50 - 65 - 80	40 - 55 - 70	-	-	50 - 60 - 70
	-	35 - 45 - 55	-	45 - 60 - 75	35 - 50 - 65	-	-	45 - 55 - 65
	-	-	-	-	-	-	-	-
	-	-	-	-	-	-	-	-
	-	-	-	-	-	-	-	-
	-	35 - 40 - 45	10 - 15 - 20	-	-	-	-	-
	-	-	-	-	-	-	80 - 140 - 200	-
	-	35 - 40 - 45	10 - 15 - 20	-	-	-	80 - 140 - 200	-



Recommended cutting data
Parametri di taglio suggeriti

Maximale Vorschübe und Spantiefen

Max. feed rate and depth of cut

Avanzamenti e profondità di taglio massimi

- f_v [mm/U] = **Vorschub ins Volle** / Feed rate into solid / Avanzamento nel pieno
- f_n [mm/U] = **Vorschub beim Einstechen** / Feed rate for re-grooving / Avanzamento di ripresa
- f_k [mm/U] = **Vorschub beim Kopieren** / Feed rate for copying / Avanzamento per copiatura
- a_p [mm] = **Spantiefe** / Depth of cut / Profondità di taglio

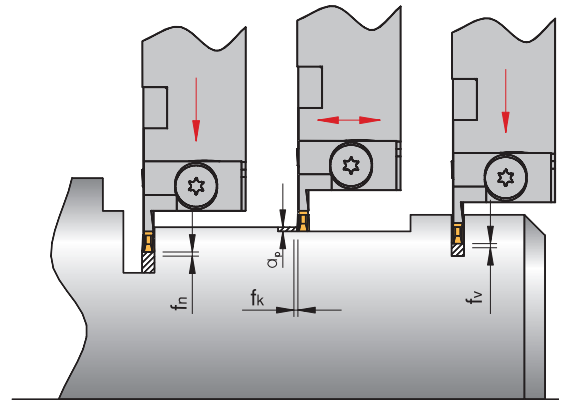

3

Standardausführung / Standard geometry / Esecuzione standard

	Schneideinsatz / Insert / Inserto							
	21201	31602	32002	42202	52502	63002	83804	104604
f_v	0,02–0,08	0,02–0,08	0,05–0,12	0,07–0,18	0,07–0,18	0,07–0,18	0,10–0,25	0,10–0,25
f_n	0,02–0,08	0,02–0,08	0,05–0,12	0,07–0,18	0,07–0,18	0,07–0,18	0,10–0,30	0,10–0,30
f_k	0,02–0,05	0,02–0,05	0,05–0,10	0,05–0,10	0,05–0,10	0,07–0,15	0,12–0,25	0,12–0,25
$a_p \text{ max}$	0,30	0,30	0,50	0,50	0,50	0,50	1,00	1,00

Kopierausführung / Geometry for copying / Geometria a copiare

-12

	Schneideinsatz / Insert / Inserto							
	21201-12	31602-12	32002-12	42202-12	52502-12	63002-12	83804-12	104604-12
f_v	0,02–0,08	0,02–0,08	0,05–0,15	0,07–0,18	0,07–0,18	0,07–0,18	0,10–0,18	0,10–0,18
f_n	0,02–0,08	0,02–0,08	0,05–0,15	0,07–0,18	0,07–0,18	0,07–0,18	0,10–0,30	0,10–0,30
f_k	0,02–0,05	0,02–0,05	0,05–0,10	0,07–0,18	0,07–0,18	0,07–0,18	0,10–0,30	0,10–0,40
$a_p \text{ max}$	0,50	0,50	1,50	2,00	2,50	2,50	3,50	4,00

Stechdrehen / Groove turning / Scanalatura di copiatura

-AM

	Schneideinsatz / Insert / Inserto							
	21202-AM	31602-AM	32002-AM	42204-AM	52504-AM	63008-AM	83808-AM	104608-AM
f_v	0,02–0,08	0,02–0,08	0,04–0,15	0,07–0,18	0,07–0,25	0,10–0,25	0,10–0,40	0,10–0,40
f_n	0,02–0,08	0,02–0,08	0,04–0,15	0,07–0,18	0,07–0,25	0,10–0,25	0,10–0,40	0,10–0,40
f_k	0,02–0,12	0,02–0,12	0,04–0,15	0,07–0,18	0,07–0,25	0,10–0,25	0,10–0,40	0,10–0,40
$a_p \text{ max}$	0,50	0,50	1,50	2,00	2,50	2,50	3,50	4,00

Vollradiusausführung / Full radius execution / Esecuzione a raggio completo

-V

	Schneideinsatz / Insert / Inserto							
	21210 V	31615 V	32015 V	42220 V	52525 V	63030 V	83840 V	104650 V
f_v	0,02–0,05	0,02–0,05	0,05–0,10	0,05–0,10	0,05–0,10	0,07–0,12	0,07–0,15	0,07–0,15
f_n	0,02–0,05	0,02–0,05	0,05–0,10	0,05–0,10	0,05–0,10	0,07–0,12	0,07–0,15	0,07–0,15
f_k	0,02–0,05	0,02–0,05	0,05–0,10	0,05–0,10	0,05–0,10	0,07–0,12	0,07–0,15	0,07–0,15
$a_p \text{ max}$	0,30	0,30	0,50	0,50	0,50	0,50	1,00	1,00

Die Tabellenwerte sind Richtwerte. Es kann notwendig sein, die Werte den jeweiligen Bearbeitungsumständen anzupassen.
The recommended cutting data are only approximate values. It may be necessary to adjust them to each individual machining application.
I dati indicati in tabella sono valori approssimati. Può essere necessario adattarli alle singole applicazioni di lavorazione.

Recommended cutting data
Parametri di taglio suggeriti

Vollradiusausführung / Full radius execution / Esecuzione a raggio completo

-VK

	Schneideinsatz / Insert / Insetto							
	21210 VK	31615 VK	32015 VK	42220 VK	52525 VK	63030 VK	83840 VK	104650 VK
f_v	0,02–0,05	0,02–0,05	0,05–0,12	0,05–0,12	0,05–0,12	0,07–0,12	0,07–0,15	0,07–0,15
f_n	0,02–0,05	0,02–0,05	0,05–0,12	0,05–0,12	0,05–0,12	0,07–0,25	0,07–0,30	0,07–0,30
f_k	0,02–0,05	0,02–0,05	0,05–0,15	0,05–0,12	0,08–0,12	0,07–0,30	0,07–0,30	0,07–0,40
$a_p \text{ max}$	0,50	0,50	1,50	2,00	2,50	3,00	4,00	5,00

Aluminiumausführung / Aluminium geometry / Geometria alluminio

-ALU

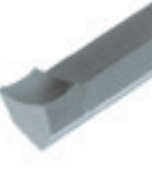
	Schneideinsatz / Insert / Insetto							
	21201-ALU	31602-ALU	32002-ALU	42202-ALU	52502-ALU	63002-ALU	83804-ALU	104604-ALU
f_v	0,02–0,08	0,02–0,12	0,05–0,18	0,05–0,18	0,05–0,18	0,05–0,18	0,10–0,25	0,10–0,25
f_n	0,02–0,08	0,02–0,12	0,05–0,18	0,05–0,18	0,05–0,18	0,05–0,18	0,10–0,30	0,10–0,30
f_k	0,02–0,10	0,02–0,15	0,05–0,20	0,05–0,20	0,05–0,20	0,05–0,20	0,10–0,35	0,10–0,35
$a_p \text{ max}$	0,50	0,50	2,00	2,50	3,00	3,00	4,00	5,00

Ausführung für Sicherungsringestiche / Circlip inserts / Insetti per sedi seeger

	Schneideinsatz / Insert / Insetto		
	2-...	3M-...	3-...
f_v	0,01–0,05	0,01–0,05	0,01–0,10

Die Tabellenwerte sind Richtwerte. Es kann notwendig sein, die Werte den jeweiligen Bearbeitungsumständen anzupassen.
The recommended cutting data are only approximate values. It may be necessary to adjust them to each individual machining application.
I dati indicati in tabella sono valori approssimati. Può essere necessario adattarli alle singole applicazioni di lavorazione.

3

Auswahl des Halters / Selecting the toolholder / Scelta dello stelo

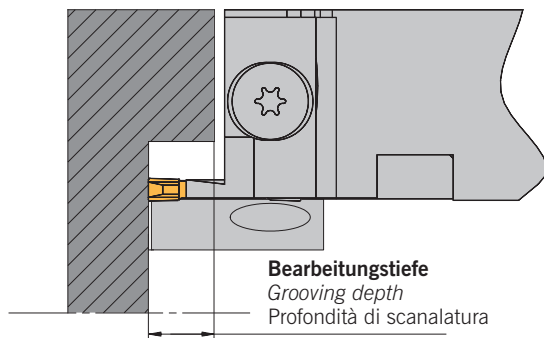

Einsatz eines Halters mit maximalen Schaftabmessungen. Zur Vermeidung oder Minimierung von Vibrationen und Werkzeugauslenkung, Auswahl des Werkzeuges (Halter, Unterstützplatte) mit der geringsten Auskraglänge, entsprechend der geforderten Bearbeitungstiefe.

The maximum shank cross section should be used. In order to minimize vibration, the tool and support blade should be setup with minimum overhang.

Scegliere lo stelo dalla sezione massima di gambo. Per ridurre le vibrazioni, l'utensile e la lama devono essere montati con una sporgenza minima.

Auswahl des Schneideinsatzes / Selecting the inserts / Scelta dell'inserto

Die Breite des Schneideinsatzes sollte, bezogen auf die Abmessungen des Werkzeuges, so breit wie möglich gewählt werden, um eine optimale Stabilität zu erreichen. Die Breite des Schneideinsatzes hat unmittelbare Auswirkung auf die Auskraglänge des Werkzeuges. Es ist der größtmögliche Eckenradius zu wählen. Ein Schneideinsatz mit größerem Radius ist stabiler und garantiert längere Standzeit durch bessere Verteilung der Schnittkräfte. Ein größerer Radius erhöht in der Regel die Oberflächenqualität beim Drehen. Der Radius sollte größer sein als der maximal gewählte Vorschub. Die kleinste Schnitttiefe „ a_p “ sollte nicht kleiner sein als der Eckenradius des Schneideinsatzes.

In order to achieve maximum stability, the widest possible insert (depending on the size of the tool) should be selected. The grooving depth of the tool is depending on the width. The largest possible corner radius should be used. A insert with a larger corner radius gives more stability and better tool-life, as the cutting forces are equalized. A large corner radius improves the surface quality. The radius should be larger than the maximum feed rate. The smallest depth cut should not be less than the corner radius of the insert.

Per ottenere la massima stabilità, è consigliabile selezionare l'inserto più largo possibile (considerando la misura dell'utensile). La profondità di scanalatura dell'utensile dipende dalla larghezza. È suggerito scegliere raggi di punta più ampi possibili. Un inserto di scanalatura con raggio di punta ampio dà maggiore stabilità e durata, e le forze di taglio contenute. Un raggio di punta ampio permette una migliore qualità superficiale. Il raggio dovrebbe essere più largo dell'avanzamento massimo. La profondità di taglio più piccola non dovrebbe essere minore del raggio di punta dell'inserto di scanalatura.

Einrichten des Werkzeuges / Set up of the tool / Installazione dell'utensile

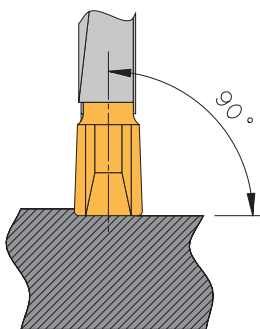

Optimale Bearbeitungsergebnisse sind nur zu erzielen, wenn das Werkzeug sachgemäß eingerichtet ist. Hierbei ist zu beachten, dass das Werkzeug (Schneidkante) stets rechtwinklig (bzw. parallel beim Axial-Stechedrehen) zur Werkstückrotationsachse ausgerichtet wird. Beim Kopierdrehen ist die zweite Schneidenecke um 0,05 mm freizustellen.

ACHTUNG: Bei unsachgemäßer Ausrichtung der Schneidkante können Vibrationen auftreten.

Optimal processing results can only be achieved if the tool is correctly mounted. Whereby it should be noted that the tool (cutting edge) must be always mounted at right angles to the work piece rotating axis (or respectively parallel with axial groove turning). With duplicating turning, the second corner is to be released 0.05 mm.

ATTENTION: If cutting edges are not set correctly, vibration can be caused.

I migliori risultati di lavorazione possono essere ottenuti solo se l'utensile è montato correttamente. Per cui bisogna considerare che l'utensile (il tagliente) deve essere sempre montato ai corretti angoli rispetto all'asse rotante del pezzo da lavorare (o rispettivamente parallelo alla tornitura assiale del canale). In tornitura di copiatura, il secondo tagliente deve arretrare di 0,05 mm.

ATTENZIONE: Se i taglienti non vengono impostati correttamente si possono originare vibrazioni.

Beispiele / Examples / Esempi

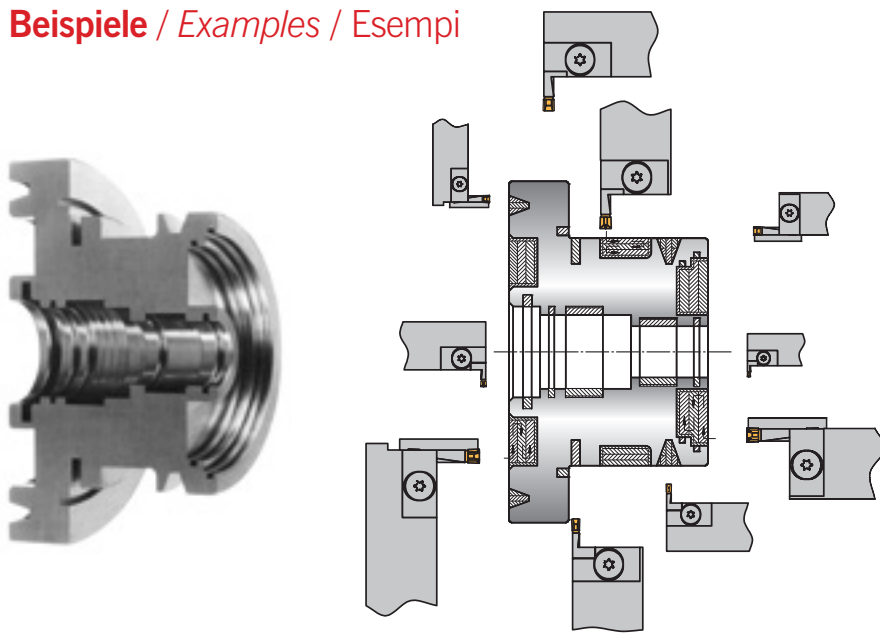

Die Schraffur macht die Schnittaufteilung deutlich und zeigt gleichzeitig die abschließende Kopieroperation.

- Musterteil aus 16MnCr5
- durchschnittliche Schnittgeschwindigkeit 150 m/min
- Vorschübe von 0,1 bis 0,25 mm

The shaded area shows the sequence of operations as well as the final profiling cut, with the Nprecision grooving tools.

- A low tensile steel was used for this component
- Average cutting speed 150 m/min
- Feed rates 0.1 up to 0.25 mm/rev

L'illustrazione mostra la sequenza delle operazioni la profilatura finale con l'uso degli utensili di scanalatura di precisione NC.

- Per questo esempio si utilizza un acciaio basso legato 16MnCr5
- Velocità di taglio 150 m/min
- Avanzamento da 0,1 a 0,25 mm

3

Einstecken ins Volle / Grooving into solid / Scanalatura nel pieno

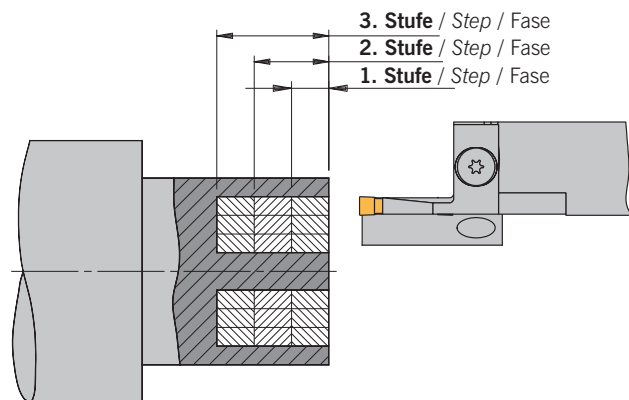

Bei großen Stechtiefen ist ein stufenweises Einstecken zu empfehlen, um Spanräume zu schaffen. Erst danach wird tiefer eingestochen.

If large groove depths are required, rough out in a series of plunges, before finishing the profile down each side and blending into the centre.

Se sono richieste scanalature profonde, procedere con una serie di passate al fine di creare uno spazio d'evacuazione del truciolo, poi scanalare più in profondità.

Innenstechen / Internal grooving / Scanalatura interna

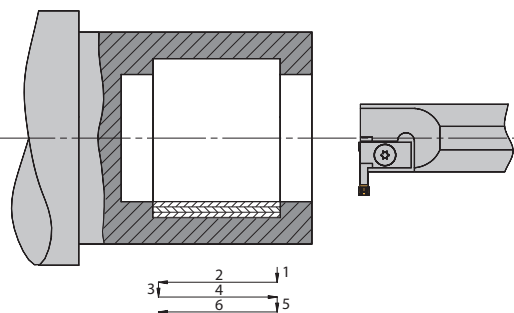

Verwendung der Schneideinsätze – 12 oder -AM

Using insert type – 12 or -AM

Utilizzo dell'inserto – 12 o -AM

Ein- oder Auswärtskopieren

Inward- and outward copy-turning

Copiatura in entrata o in uscita

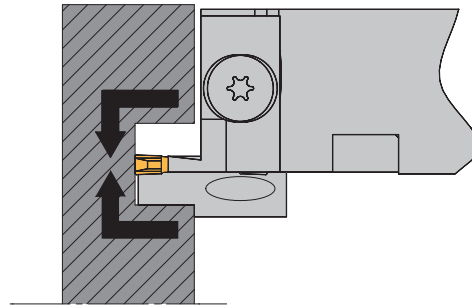

Einwärtskopieren bewirkt einen besseren, gleichmäßigeren Spanbruch und ist zur Minimierung des Werkzeugverschleißes zu empfehlen. Der Span fließt in den bearbeiteten Raum ab. Senkrecht / Rechtwinklig: Um eine gute Rechtwinkligkeit zwischen den Seitenwänden zu erhalten, empfiehlt sich das Einwärtskopieren.

Inward copy-turning gives a more uniform chip-breaking and minimizes insert wear. In order to achieve rectangular faces, we recommend inward copy-turning.

La copiatura in uscita permette una rottura del truciolo uniforme e minimizza l'usura dell'inserto. Perpendicolarità/Parallelismo: per ottenere una buona perpendicolarità ed un buon parallelismo raccomandiamo la copiatura in uscita.

3

Axial-Stechen und Plandrehen

Axial grooving and facing

Scanalatura assiale e sfacciatura

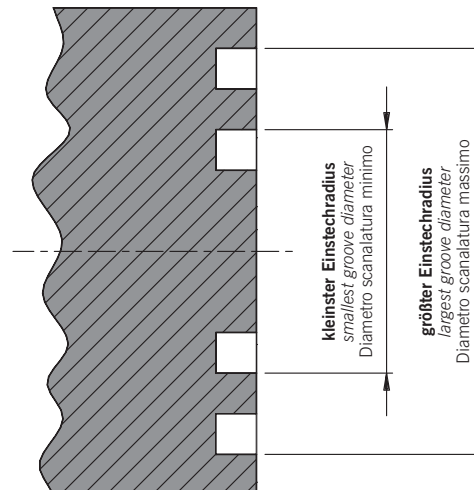

Axial-Stechen ist nur innerhalb des festgelegten Durchmesserbereiches möglich (z. B. 50–60). Andernfalls kann es zur Beschädigung oder Zerstörung des Werkzeuges kommen.

Axial grooving is only possible within the diameter range (e. g. 50–60). If not, the tool can be damaged or destroyed.

La scanalatura assiale è possibile solo entro la gamma di diametri determinati (per es. 50–60). Una scelta scorretta causerebbe la collisione tra utensile e pezzo da lavorare.

ACHTUNG: Der angegebene Durchmesserbereich gilt immer für den Außendurchmesser der Nut!

ATTENTION: The specified diameter range in all cases refers to the outer diameter of the groove!

ATTENZIONE: La gamma dei diametri specifici si riferisce in ogni caso al diametro più esterno della gola in prima piantata.

ACHTUNG / ATTENTION / ATTENZIONE

Beim Axial-Stechen immer am Nutaußendurchmesser starten.
Nutverbreiterungen über den angegebenen Durchmesserbereich hinaus sind nach oben und unten möglich.

Der erste Einstich muss im angegebenen Durchmesserbereich liegen. Die Tiefe der Einstiche zur Nutverbreiterung darf nicht größer als die des ersten Einstichs sein.

When axial grooving always begin at the groove outside diameter.
Once the first plunge is complete, it is possible to widen the groove above and below the diameter range quoted.

The first groove made must be within the quoted diameter range. The depth of the next cut must not be deeper than the depth of the first groove.

Nella scanalatura assiale occorre sempre iniziare con il diametro esterno.
Una volta completata la prima piantata è possibile allargare il canale al di sopra e al di sotto della gamma di diametro lavorato.

Il primo canale prodotto deve essere entro la gamma diametro indicato sulla lama. La profondità della gola successiva non deve essere più profonda della profondità della prima.

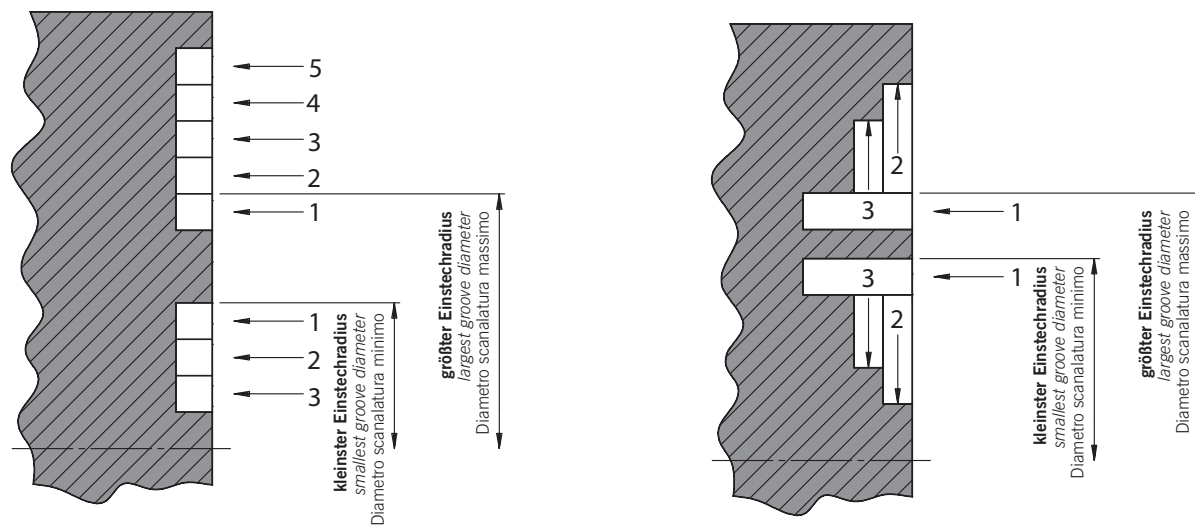



- Modulares NC-Stechdrehsystem für verschiedene Werkzeugvarianten mit einem Grundhalter durch einfachen Austausch von Unterstutzplatte und Klemme.
- Komplettes Programm für die axiale und radiale Außenbearbeitung in verschiedenen Stechbreiten.
- Für die Innenbearbeitung besteht ein Programm in verschiedenen Haltergrößen (wahlweise mit oder ohne innere Kühlmittelzufuhr) und Stechbreiten.
- Für größere Bearbeitungstiefen stehen spezielle Klemmen und Unterstutzplatten zur Verfügung.
- Kompakthalter mit VDI- und UTS-/KM und Capto®-Aufnahmen für erhöhte Stabilität. Diese Halter können ebenfalls mit dem gesamten Standardzubehör kombiniert werden.
- A modular grooving and copy-turning system giving different tool variations from one basic holder by simply exchanging the support blade and clamp.
- A complete programme for external radial and axial grooves of various widths.
- For internal machining a range of boring bars with and without coolant feed and inserts in different widths are available.
- For deep grooving applications special support blades and clamps can be designed and manufactured.
- Toolholder with VDI or UTS/KM and Capto® shanks, which can give improved stability, along with their spares are stock items. These holders are used in conjunction with standard support blades, clamps and inserts.
- Un sistema di tornitura-scanalatura modulare permette differenti varianti d'utensile con il semplice cambio della lama e della staffa.
- Un programma completo per lavorazioni esterne assiali e radiali con larghezze di taglio differenti.
- Per la lavorazione interna, esiste un programma di steli con sezioni differenti (con un sistema di raffreddamento centrale) e larghezze di taglio differenti.
- Per profondità di taglio non standard è possibile studiare apposite lame e staffe speciali.
- Sono disponibili attacchi VDI, UTS/KM e Capto® per una stabilità superiore. Questi attacchi possono essere combinati con l'insieme degli accessori standard.



- Präzisionsgeschliffene bzw. gesinterte, 2-schneidige Schneideinsätze für die Innen- und Außenbearbeitung.
- Verschiedene Spanformgeometrien sowie eine Vielzahl von Schneidstoffen mit speziell abgestimmten Beschichtungen bieten eine optimale Auswahl für den jeweiligen Bearbeitungsfall.
- Lange Prismenführung der Schneideinsätze für optimale Kontrolle der Schnittkräfte beim Längsdrehen und Kopieren.
- Positive Schneidgeometrie erlaubt Programmkorrekturen im Bereich von 0,01 mm und eignet sich somit für Schlichtoperationen aller Art.
- Precision or sintered ground inserts with two cutting edges for use on internal and external grooving applications.
- A choice of chipbreaker geometries together with coated and uncoated carbide grades, combine to offer optimum cutting performance on a wide range of materials.
- Inserts have a ground vee seating for a positive location into the support blade. This ensures maximum stability when side turning or copying.
- The positive insert geometry minimises deflection (less than 0.01 mm) and is therefore particularly suitable for finishing operations.
- Inserti a due taglienti rettificati di precisione o sinterizzati per lavorazioni interne ed esterne.
- Le differenti geometrie di taglio insieme alla grande diversità di gradi con rivestimenti specifici offrono una scelta ottimale per qualsiasi lavorazione.
- La lunghezza del prisma dell'inserto offre un controllo ottimale delle forze di taglio nella tornitura longitudinale e nella copiatura.
- La geometria di taglio positiva permette delle correzioni di programmazione nell'ordine di 0,01 mm e favorisce tutte le lavorazioni di finitura.

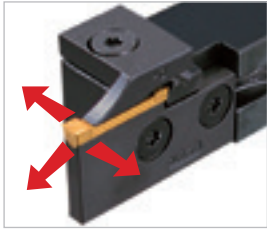

- **Stechdrehen in 3 verschiedene Hauptschnitt-richtungen. Dadurch Verbundoperationen mit nur einem Werkzeug möglich.**
- *Tools and operate in three directions offering the opportunity to consolidate several operations into one and reduce the number of tool changes.*
- La tornitura-copiatura tri-direzionale è ottenuta con un solo utensile.

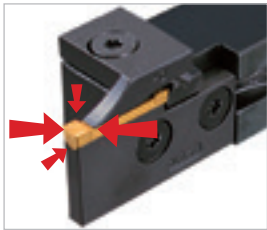

- **Die Klemmtechnik in Verbindung mit der Prismenführung verhindert ein seitliches Abkippen der Schneideinsatz bei Längsdrehoperationen und sichert durch die breite axiale Auflage die hohe Wiederholgenauigkeit.**
- **Die freigestellte Unterstützplatte garantiert eine optimale Plattenauflage und sichert die Stabilität bei einseitigen Belastungen.**
- *The design of the insert clamping and the vee location provides for accurate indexing of insert edges and index repeatability is achievable.*
- *The relief in the support blade means the insert is supported under the ends to ensure high stability and optimum rigidity.*
- La tecnica di serraggio, associata al prisma dell'inserto permette di evitare il suo movimento all'interno della sede.
- Il sostegno della lama di supporto garantisce una stabilità ottimale dell'inserto nella sua sede e assicura la stabilità negli sforzi di taglio laterali.



- **Zur Komplettierung des Stechdrehprogrammes stehen weiterhin Monoblock-Halter im Axialbereich für Nut-Außendurchmesser ab D_{\min} 15 mm und Mini-Innenstechdrehwerkzeuge ab D_{\min} 11 mm zur Verfügung.**
- *To complete the grooving programme, there are monoblock holders for axial grooving diameters of 15 mm upward. Also an internal boring bar for 11 mm minimum bore diameter are available.*
- Per completare il programma di tornitura-copiatura, esistono anche utensili monoblocco, per lavorazione assiale, per diametri esterni minimi di 15 mm. La gamma prevede inoltre utensili per interni come i sistemi AMS e SIM per diametri a partire da 2,5 mm.

Montage ARNO-NC-Stechdrehsystem

Assembling of ARNO-Groove turning system

Montaggio del sistema ARNO di Scanalatura e copiatura

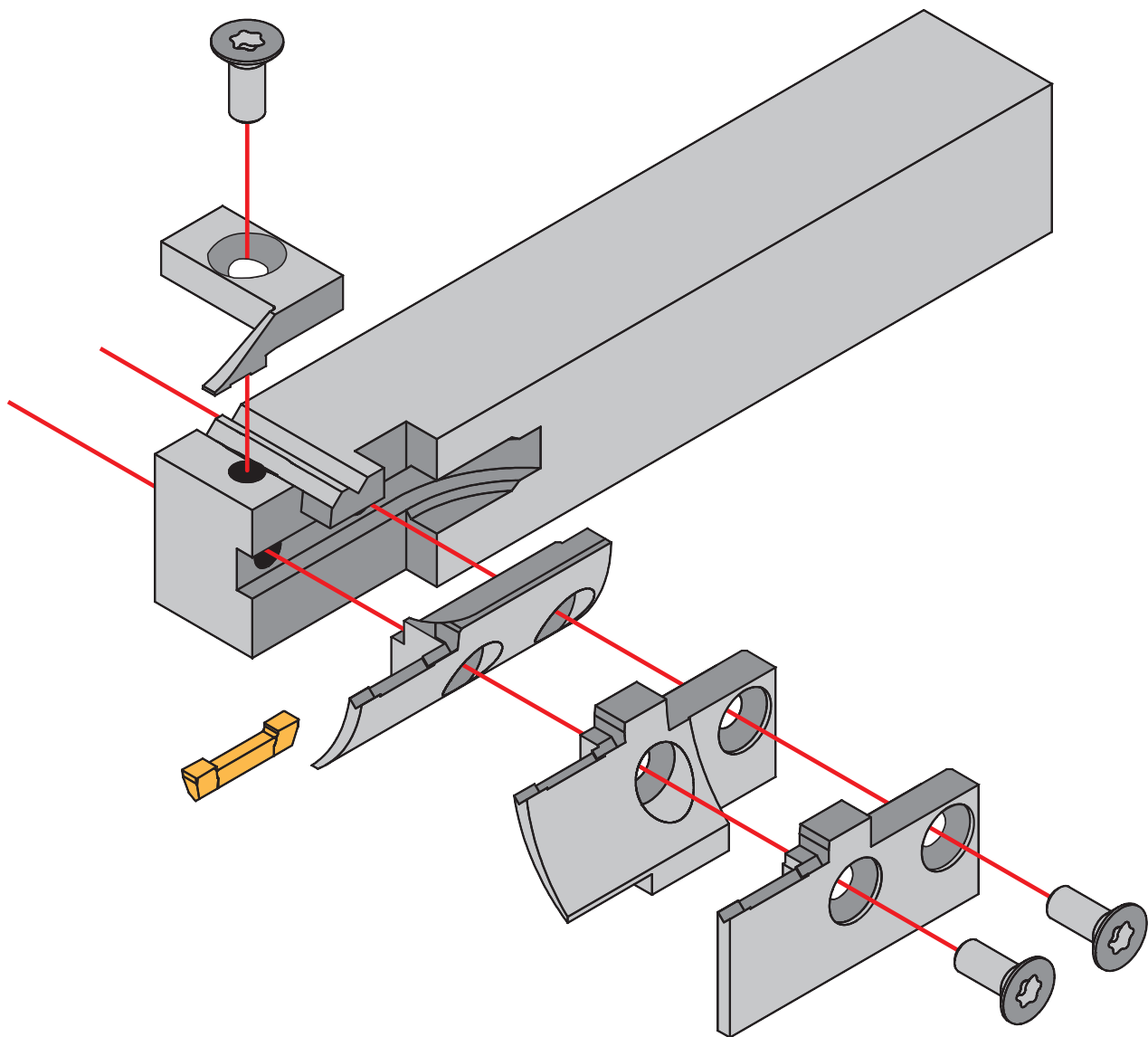

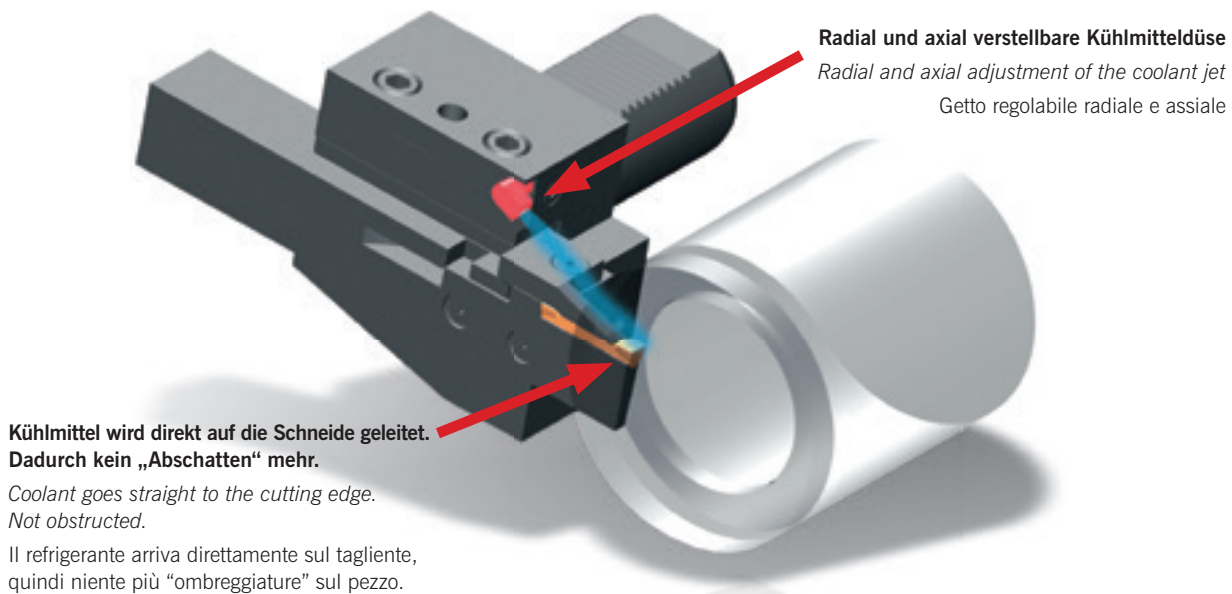
Systemübersicht SBN/KMH / System overview SBN/KMH /
Panoramica del sistema SBN e KMH**KMH – Werkzeughalter** / KMH tool holder / Adattatori KMH

3

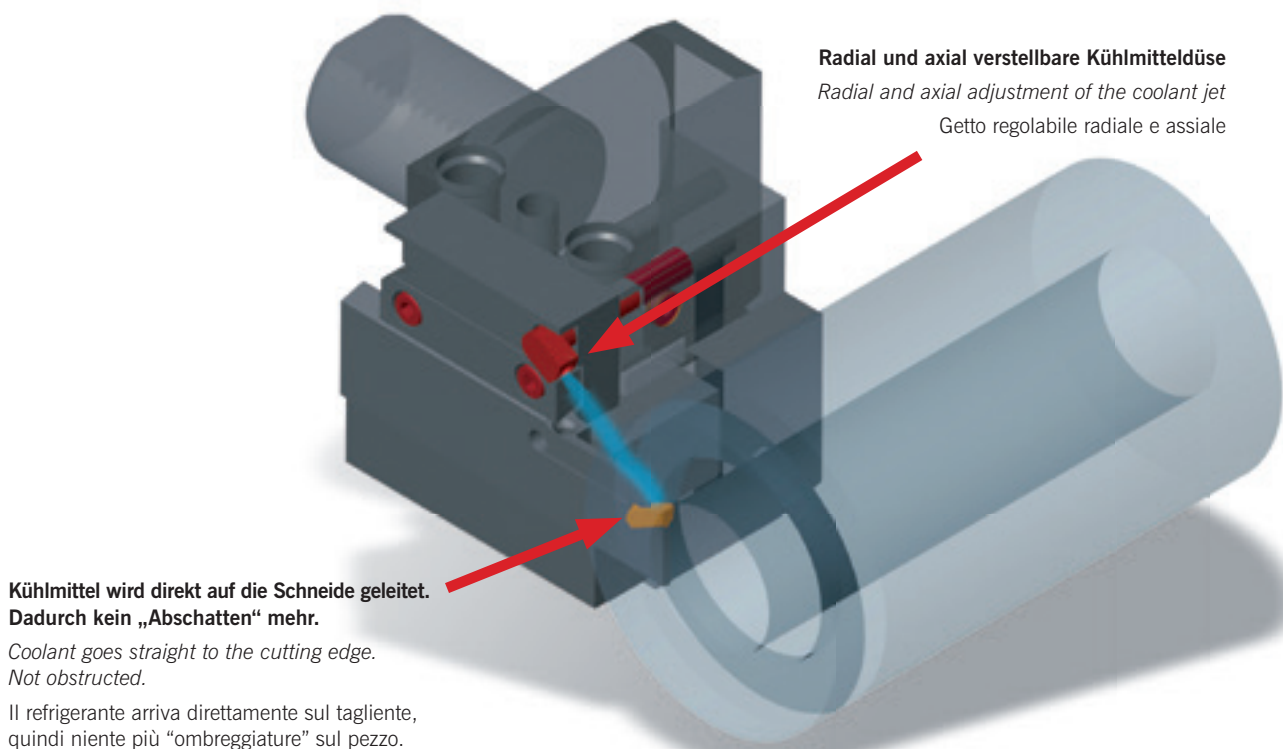
SBN Spannblock / SBN Parting block / SBN Blocco portalama

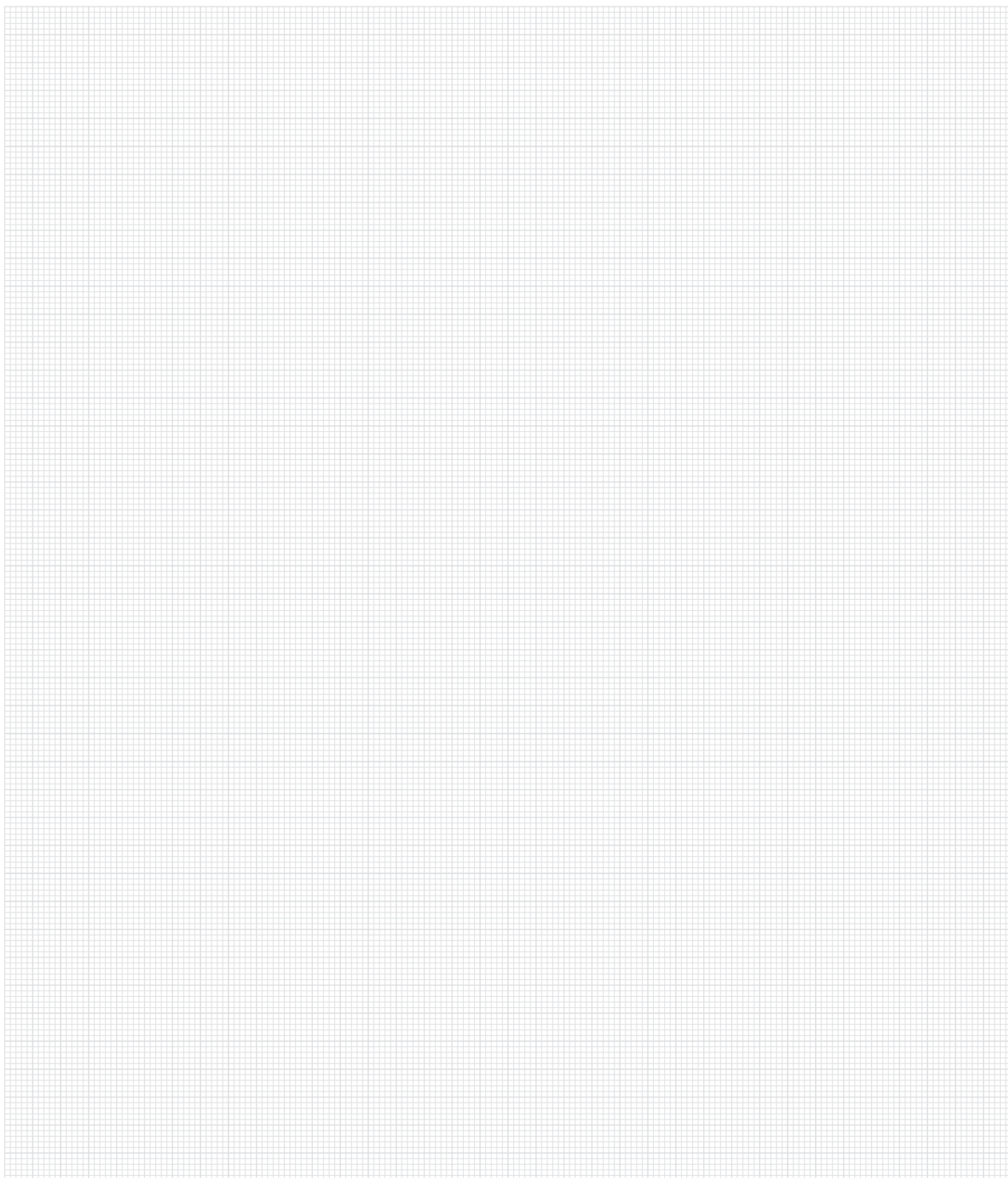

Weitere Informationen finden Sie unter:

For more information see:

Per maggiori informazioni visita il sito:

www.arno.de

SHORT-CUT

SHORT-CUT

SHORT-CUT

Stechdrehsystem zum Außen- und Innenstechdrehen

Groove turning system for external and internal grooving and copy-turning

Sistema di scanalatura e copiatura esterna e interna

- Systemvorstellung
- Werkzeugauswahl
- Bezeichnungssystem
- Monoblockhalter – Außenstechdrehen
- **SIS** Bohrstangen – Innenstechdrehen
- Geometrie
- Sortenbeschreibung
- Schneideinsätze
- Ersatzteile und Zubehör
- Schnittwerte

- Introduction
- Tool shank options
- Designation system
- Monoblock holders – External groove turning
- **SIS** Boring bars – Internal groove turning
- Geometry
- Grade description
- Inserts
- Spare parts and accessories
- Cutting data

- Caratteristiche del sistema **280 – 281**
- Tipologie di corpo utensile **282**
- Sistema di identificazione **283 – 284**
- Utensili monoblocco – di scanalatura esterna **285 – 287**
- **SIS** Barenì – di scanalatura interna **288**
- Geometria **289**
- Descrizione delle Qualità **290 – 291**
- Inserti **292 – 295**
- Ricambi e accessori **296**
- Parametri di taglio **298 – 304**



Der „Robuste“ für die grobe Zerspanung

The rigid system for grooving and turning with one tool

Il sistema robusto per scanalatura e copiatura

Stabiles SHORT-CUT Stechdrehsystem zum Außen- und Innenstechdrehen ab D_{\min} 29,5 mm

Strong SHORT-CUT groove turning system for external and internal groove turning and copy-turning, internal from minimum bore diameter 29.5 mm

Sistema SHORT-CUT di scanalatura e copiatura esterna e interna da diametro 29,5 mm

4

Monoblockhalter Außenstechdrehen

*Monoblock holder
External groove turning*

Utensile monoblocco
di scanalatura esterna



SIS Bohrstangen Innenstechdrehen

*SIS Boring bars
Internal groove turning*

SIS Baren
di scanalatura interna



Systemvorstellung

Die Kombination von optimaler Stabilität der Halter (kurze Auskraglänge, neueste Klemmtechnik) und gesintertem, zweiseitigem Schneideinsatz (spezielle Spanformgeometrie und Schneidkantenausführung) machen unsere SHORT-CUT-Werkzeuge zum perfekten Partner für höchste Zerspanungsleistungen beim Stechdrehen.

Fakten

Monoblockhalter

- Schaft 10 x 10 bis 32 x 25 mm
- 7 Plattengrößen (LOMX...)
- präzisionsgesintert
- Stechbreiten 2 – 10 mm
- Einstechtiefe bis 27 mm

Bohrstangen

- Innere Kühlmittelzuführung durch die Patze „SIS“
- 2 Plattengrößen (LOMX...)
- Stechbreiten 3 und 4 mm
- Einstechtiefe max. 14 mm

Introduction

The combination of optimum stability in the holder (short overhang, latest clamping technique) and sintered double-sided insert (special chip geometry and cutting edge preparation) makes the SHORT-CUT system the best partner for high machining outputs in grooving and turning applications.

Features

Monoblock holders

- Shank sizes 10 x 10 to 32 x 25 mm
- 7 insert sizes (LOMX...)
- Precision sintered
- Groove width 2 – 10 mm
- Groove depth up to 27 mm

Boring bars

- Through tool coolant supply
- 2 insert sizes (LOMX...)
- Groove width 3 and 4 mm
- Groove depth maximum 14 mm

Descrizione

La combinazione di una stabilità ottimale dello stelo (le più innovative tecniche di serraggio) e di inserti bitaglianti sinterizzati (geometrie speciali e diversi tipi di preparazione taglienti) rendono il nostro utensile SHORT-CUT il sistema perfetto per le migliori prestazioni in scanalatura.

Caratteristiche

Utensili monoblocco

- Stelo da 10 x 10 a 32 x 25 mm
- 7 Dimensioni inserto (LOMX ...)
- Inserti sinterizzati di precisione
- Larghezze di taglio 2 – 10 mm
- Profondità gola fino a 27 mm

Bareni

- Adduzione refrigerante interna attraverso staffa “SIS”
- 2 dimensioni di inserti (LOMX ...)
- Larghezze di taglio 3 e 4 mm
- Profondità gola max. 14 mm



Monoblockhalter – Außenstechdrehen / *Monoblock holders – External groove turning* / *Utensili monoblocco – di scanalatura esterna*

Seite/Page/Pagina **285 – 287**

4



SIS Bohrstangen – Innenstechdrehen / *SIS Boring bars – Internal groove turning* / *SIS Baren di scanalatura interna*

Seite/Page/Pagina **288**



Schneideinsätze / *Inserts* / *Inserti*

Seite/Page/Pagina **292 – 295**

Designation system
Sistema di identificazione

Monoblockhalter / Monoblock holders / Utensili monoblocco

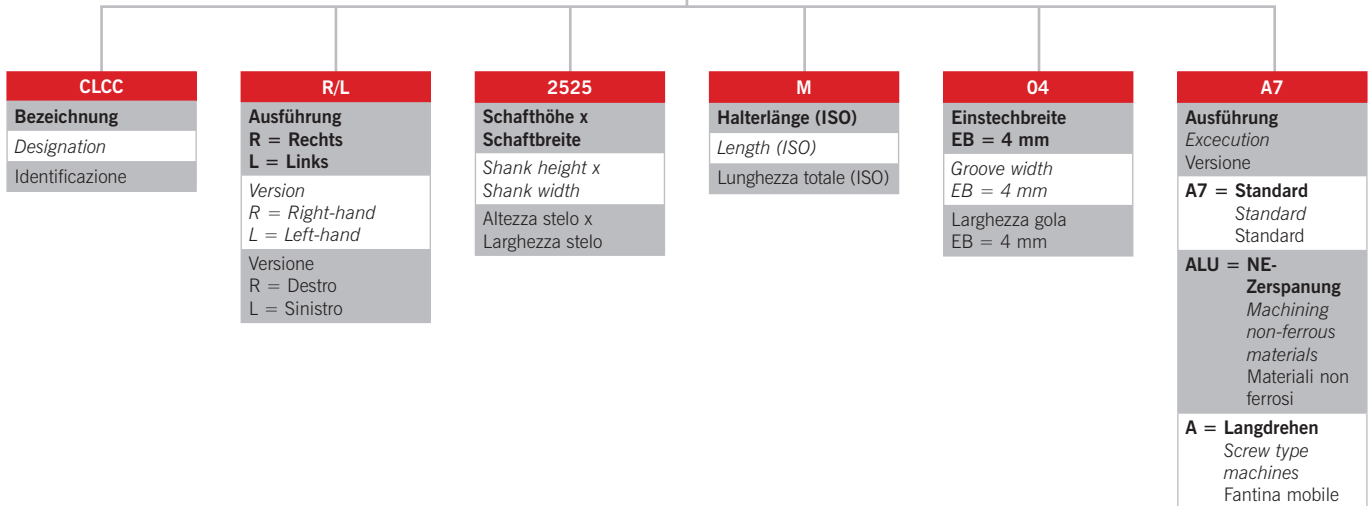

4

SIS Bohrstanzen / SIS Boring bars / SIS Baren

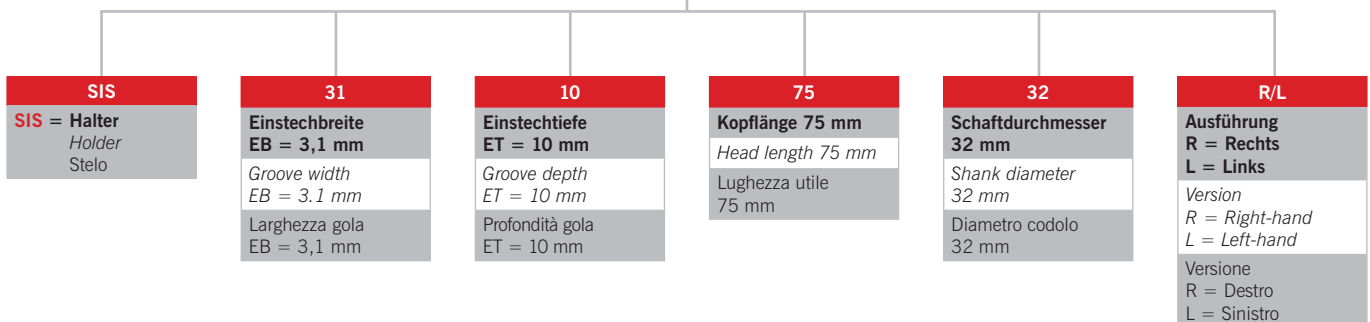

Schneideinsätze / Inserts / Inserti



LOMX	18	04	04	EN	AM	350
ISO-Bezeichnung	Plattenlänge 18 mm	Einstechbreite	Eckenradius	Schneidkante	ARNO®-Einsatzgebiet	Schneidstoffcode (ISO-Gruppierung)
ISO-Designation	Insert length 18 mm	EB = 4 mm	R = 0,4 mm	Edge condition	ARNO®-Application area	Grade code (ISO)
Identificazione ISO	Lunghezza inserto 18 mm	Inserts width EB = 4 mm	Corner radius R = 0.4 mm	Preparazione tagliente	ARNO®-Campo utilizzo	Qualità (ISO)
		Larghezza gola EB = 4 mm	Raggio R = 0,4 mm			

4

Radial-Stechdrehen / Radial groove turning / Scanalatura radiale

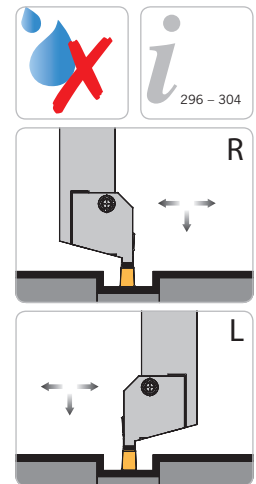
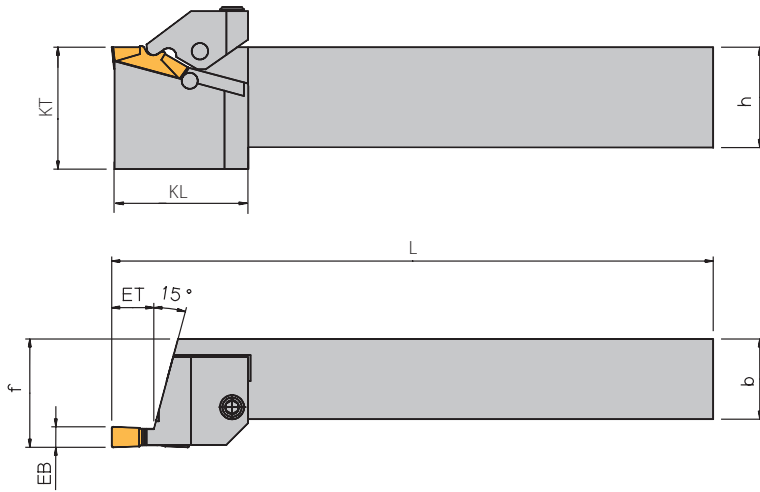

Rechte Ausführung abgebildet
Right-hand execution shown
Versione destra in figura

Trägerwerkzeuge / Holders / Utensili

Bezeichnung Designation Articolo	EB	ET	ET _{max}	h	b	L	KL	KT	f	PG 12	Schneideinsatz Insert Inserto
CLCCL/R 1616J03-A7	3,1	6,5	10,5	16	16	110	-	-	23	●	LOMX 15
CLCCL/R 1616J04-A7	4,1	8,5	13,0	16	16	110	-	-	23	●	LOMX 18
CLCCL/R 2020K03-A7	3,1	6,5	10,5	20	20	125	-	-	27	●	LOMX 15
CLCCL/R 2020K04-A7	4,1	8,5	13,0	20	20	125	-	-	27	●	LOMX 18
CLCCL/R 2020K05-A7	5,1	10,5	15,0	20	20	125	-	-	27	●	LOMX 20
CLCCL/R 2020K06-A7	6,1	12,5	18,5	20	20	125	39	25	27	●	LOMX 24
CLCCL/R 2525M03-A7	3,1	6,5	10,5	25	25	150	-	-	32	●	LOMX 15
CLCCL/R 2525M04-A7	4,1	8,5	13,0	25	25	150	-	-	32	●	LOMX 18
CLCCL/R 2525M05-A7	5,1	10,5	15,0	25	25	150	-	-	32	●	LOMX 20
CLCCL/R 2525M06-A7	6,1	12,5	18,5	25	25	150	-	-	32	●	LOMX 24
CLCCL/R 2525M08-A7	8,1	14,5	25,0	25	25	150	48	32	26	●	LOMX 32
CLCCL/R 2525M10-A7	10,1	16,5	27,0	25	25	150	48	32	26	●	LOMX 40
CLCCL/R 3225P05-A7	5,1	10,5	15,0	32	25	170	-	-	32	●	LOMX 20
CLCCL/R 3225P06-A7	6,1	12,5	18,5	32	25	170	-	-	32	●	LOMX 24
CLCCL/R 3225P08-A7	8,1	14,5	25,0	32	25	170	-	-	26	●	LOMX 32
CLCCL/R 3225P10-A7	10,1	16,5	27,0	32	25	170	-	-	26	●	LOMX 40

Die Standard-Stechtiefe der Grundhalter entspricht der Einstechtiefe ET. Die Stechtiefe kann auf Kundenwunsch bis auf maximale E_{tmax} nachgearbeitet werden. Durch diese Nacharbeit reduziert sich die Stabilität, daher Reduzierung der Schnittdaten um ca 30%

The standard recess depth of the basic support corresponds to the recess depth ET. At the request of the customer, the recess depth can be extended to the maximum recess depth, max. ET
La profondità del recesso standard del supporto di base corrisponde alla profondità di recesso ET. La profondità di recesso può essere estesa alla massima profondità di recesso ET max.

Bei Bestellung bitte unbedingt Einstechtiefe in Bestellbezeichnung angeben. z.B.: CLCCL 2525M04-A7-12!

When ordering make sure to specify the recess depth on the order form, e.g. CLCCL 2525M04-A7-12!

Nell'ordine indicare la profondità di recesso, p.e.: CLCCL 2525M04-A7-12!

Ersatzteile / Spare Parts / Ricambi

Trägerwerkzeug Holder Utensile	Klemme Clamp Staffa	Klemmlagerstift Clamping pin Spina staffa	Schraube Screw Vite	Anlagestift Support pin Spina di fermo	Schlüssel Key Chiave
CLCC R/L 03-A7	KTC3 R/L	STC ..*	GTC6N	ATC1N	KP1111
CLCC R/L 04-A7	KTC4 R/L	STC ..*	GTC6N	ATC1N	KP1111
CLCC R/L 05-A7	KTC5 R/L	STC ..*	GTC6N	ATC1N	KP1111
CLCC R/L 06-A7	KTC6 R/L	STC ..*	GTC6N	ATC1N	KP1111
CLCC R/L 08-A7	KTC8 R/L	STC 2N	GTC6N	ATC2N	KP1111
CLCC R/L 10-A7	KTC10 R/L	STC 2N	GTC6N	ATC2N	KP1111

*Schaft 16mm --> Klemmlagerstift STC3N Schaft 20mm --> Klemmlagerstift STC1N Schaft 25 und 32mm --> Klemmlagerstift STC2N

*Shank 16 --> Clamping pin STC3N Shank 20mm --> Clamping pin STC1N Shank 25 and 32mm --> Clamping pin STC2N

*Gambo 16 mm --> Asse della staffa STC-3N Gambo 20 mm --> Asse della staffa STC-1N Gambo 25 e 32 mm --> Asse della staffa STC-2N

Monoblock holders
Utensili monoblocco

Radial Stechdrehen – für die NE-Zerspanung

Radial groove turning - for machining of non-ferrous materials

Scanalatura radiale - per la lavorazione dei materiali non-ferrosi

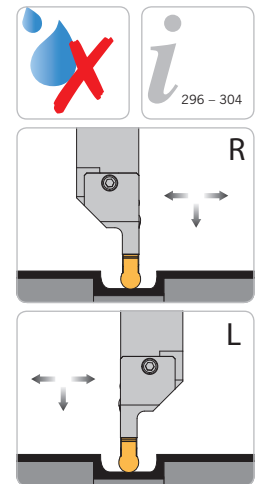
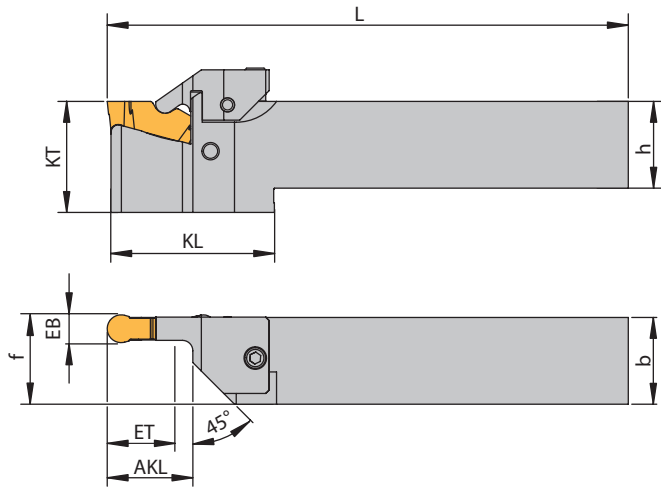

Linke Ausführung abgebildet
Left-hand execution shown
Versione sinistra in figura

N NEU/NEW/
NUOVO

Trägerwerkzeuge / Holders / Utensili

Bezeichnung Designation Articolo	EB	ET	h	b	L	KL	KT	f	AKL	PG 12	Schneideinsatz Insert Inserto
CLCCL/R 2525M06-ALU	6	21	25	25	150	48	32	25,60	24	●	LOMX 2406...FN-ACB
CLCCL/R 2525M08-ALU	6	24	25	25	150	48	32	25,75	24	●	LOMX 3208...FN-ACB
CLCCR 2532M08-ALU	8	24	25	32	150	64	40	32,80	24	●	LOMX 3208...FN-ACB

Ersatzteile / Spare Parts / Ricambi

Trägerwerkzeug Holder Utensile	Klemme Clamp Staffa	Klemmlagerstift Clamping pin Spina staffa	Schraube Screw Vite	Schlüssel Key Chiave
CLCC R/L.. 06..	KTC6 L/R-ALU	STC4N	GTC6N	KP 1111
CLCC R/L.. 06..	KTC8 L/R-ALU	STC4N	GTC6N	KP 1111

Monoblock holders
Utensili monoblocco

Radial Stechdrehen – für Langdrehautomaten

Radial groove turning - for auto lathes

Scanalatura radiale - per torni a fantina mobile

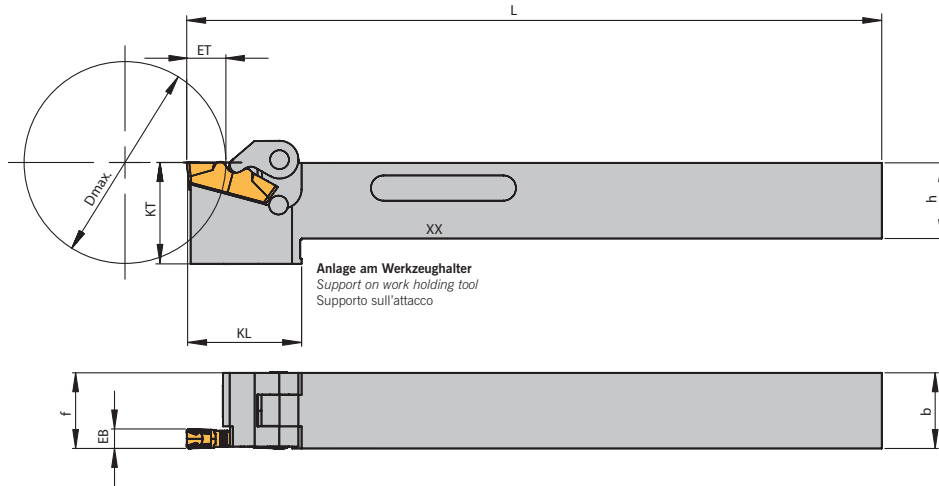
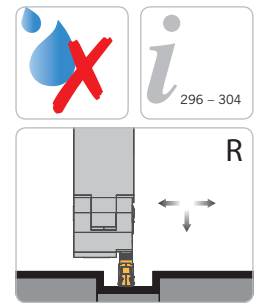

Rechte Ausführung abgebildet
Right-hand execution shown
Versione destra in figura

Trägerwerkzeuge / Holders / Utensili

Bezeichnung Designation Articolo	EB	ET	h	b	L	KL	KT	f	D _{max}	PG 12	Schneideinsatz Insert Inserto
CLCCR 1010 J02-A7-A	2,1	4,0	10	10	110	20	14	10	32	●	LOMX 12....
CLCCR 1212 J02-A7-A	2,1	4,0	12	12	110	20	16	12	32	●	LOMX 12....
CLCCR 1212 J03-A7-A	3,1	6,0	12	12	110	20	16	12	32	●	LOMX 15....
CLCCR 1616 J04-A7-A	4,1	8,0	16	16	110	-	-	16	32	●	LOMX 18....
CLCCR 1616 J05-A7-A	5,1	9,5	16	16	110	26	20.5	16	32	●	LOMX 20....
CLCCR 1616 J06-A7-A	6,1	9,5	16	16	110	26	25	16	32	●	LOMX 24....

Ersatzteile / Spare Parts / Ricambi

Trägerwerkzeug Holder Utensile	Klemme Clamp Staffa	Klemmlagerstift Clamping pin Spina staffa	Druckfeder Compressing spring Molla di compressione	Schraube Screw Vite	Schlüssel Key Chiave
CLCCR .. J02-A7-A	KTC2 R-10A	DIN6325-3M6X10	D-0900	DIN912-M4X10-12.9	KP 1111
CLCCR .. J03-A7-A	KTC3 R-12A	DIN6325-3M6X12	D-0900	DIN912-M4X10-12.9	KP 1111
CLCCR .. J04-A7-A	KTC4 R-16A	DIN6325-3M6X12	D-0900	DIN912-M4X10-12.9	KP 1111
CLCCR .. J05-A7-A	KTC5 R-16A	DIN6325-3M6X14	D-0900	DIN912-M4X10-12.9	KP 3421
CLCCR .. J06-A7-A	KTC6 R-16A	DIN6325-4M6X14	D-0900	DIN912-M4X16-12.9	KP 1321

SIS Boring bars
SIS Baren

Innenstechdrehen / Internal groove turning / Scanalatura interna

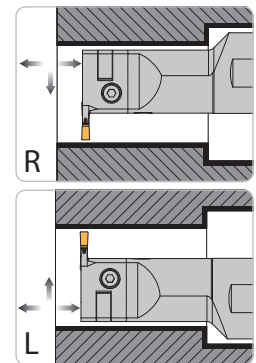
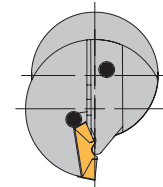
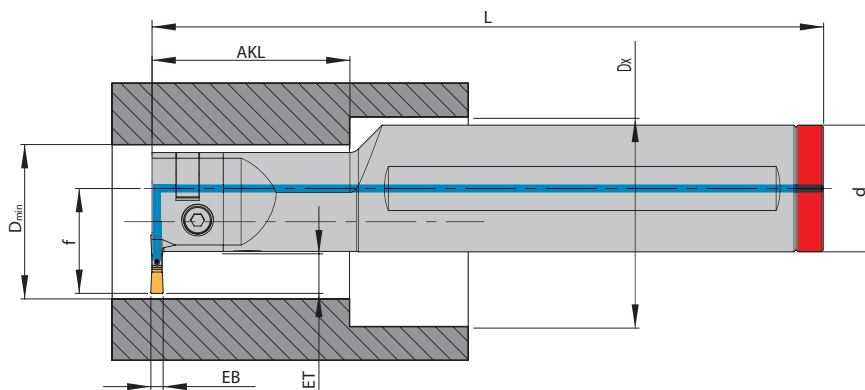

Rechte Ausführung abgebildet
Right-hand execution shown
Versione destra in figura

Trägerwerkzeuge / Holders / Utensili

Bezeichnung Designation Articolo	D _{min}	EB	ET	L	d	f	AKL	D _x	PG 12	Schneideinsatz Insert Inserto
SIS31-08-20L/R	29,5	3,1	8	130	20	18,5	30	-	●	LOMX 1503...
SIS31-08-40-25L/R	29,5	3,1	8	150	25	21,0	40	39,5	●	LOMX 1503...
SIS31-08-60-25L/R	29,5	3,1	8	150	25	21,0	60	39,5	●	LOMX 1503...
SIS31-10-25L/R	36,5	3,1	10	150	25	23,0	40	-	●	LOMX 1503...
SIS31-10-50-32L/R	36,5	3,1	10	170	32	26,5	50	50,5	●	LOMX 1503...
SIS31-10-75-32L/R	36,5	3,1	10	170	32	26,5	75	50,5	●	LOMX 1503...
SIS41-10-25L/R	36,5	4,1	10	150	25	23,0	40	-	●	LOMX 1804...
SIS41-10-32L/R	43,5	4,1	10	150	32	26,5	40	-	●	LOMX 1804...
SIS41-10-50-32L/R	36,5	4,1	10	170	32	26,5	50	50,5	●	LOMX 1804...
SIS41-10-65-40L/R	43,5	4,1	10	200	40	30,5	65	59,0	●	LOMX 1804...
SIS41-10-75-32L/R	36,5	4,1	10	170	32	26,5	75	50,5	●	LOMX 1804...
SIS41-10-100-40L/R	43,5	4,1	10	200	40	30,5	100	59,0	●	LOMX 1804...
SIS41-14-32L/R	47,5	4,1	14	180	32	30,5	40	-	●	LOMX 1804...

Ersatzteile / Spare Parts / Ricambi

Trägerwerkzeug Holder Utensile	Schraube Screw Vite	Verschlossring Locking Ring Anello di tenuta
SIS31-08-20 R/L	DIN912-M3X10-12.9	KVR 20
SIS31-08-40-25 R/L	DIN912-M3X10-12.9	KVR 25
SIS31-08-60-25 R/L	DIN912-M3X10-12.9	KVR 25
SIS31-10-25 R/L	DIN912-M4X16-12.9	KVR 25
SIS31-10-50-32 R/L	DIN912-M4X16-12.9	KVR 32
SIS31-10-75-32 R/L	DIN912-M4X16-12.9	KVR 32
SIS41-10-25 R/L	DIN912-M4X16-12.9	KVR 25
SIS41-10-32 R/L	DIN912-M4X16-12.9	KVR 32
SIS41-10-50-32 R/L	DIN912-M4X16-12.9	KVR 32
SIS41-10-65-40 R/L	DIN912-M4X16-12.9	KVR 40
SIS41-10-75-32 R/L	DIN912-M4X16-12.9	KVR 32
SIS41-10-100-40 R/L	DIN912-M4X16-12.9	KVR 40
SIS41-14-32 R/L	DIN912-M4X16-12.9	KVR 32

**Standardausführung**

- gesinterter Schneideinsatz
- zweiseitig
- zum Einstecken und Drehen bei mittleren bis großen Spanquerschnitten
- stabile Schneidkante für unterbrochenen Schnitt und stark wechselnde Spanquerschnitte
- für eine große Anzahl von Werkstückstoffen

Standard geometry

- sintered insert
- two cutting edges
- for grooving and turning with medium to large chip-cross-section
- strong cutting edge for interrupted cutting and changing chip-cross-sections
- for various materials

Esecuzione standard

- inserto sinterizzato
- 2 taglienti
- per la scanalatura e la copiatura di sezioni di truciolo medie e grandi
- tagliente stabile per il taglio interrotto e sezioni di truciolo variabili
- adatto ad una grande diversità di materiali

**AM-Geometrie**

- gesinterter Schneideinsatz
- zweiseitig
- zum Einstecken und Stechdrehen für die mittlere bis große Zerspanung
- spezielle weichschneidende Geometrie
- Zerspanung sämtlicher Stahlwerkstoffe

AM geometry

- sintered insert
- two cutting edges
- for grooving and copy-turning at medium to large chip-cross-sections
- special soft cutting geometry
- machining all steel materials

Geometria AM

- inserto a 2 taglienti sinterizzato
- per scanalatura e tornitura
- geometria positiva
- per la lavorazione di tutti gli acciai

**ACB-Geometrie**

- umfangsgeschliffener Schneideinsatz
- zweiseitig
- polierte Spanfläche
- Stechdrehen bei mittleren bis großen Spanquerschnitten
- spezielle Spanformgeometrie für kontrollierten Spanbruch
- Zerspanung von Alu und Alu-Legierungen, Leicht- und Buntmetallen sowie Titan und Titanlegierungen

ACB geometry

- completely ground insert
- two cutting edges
- polished surface
- for groove turning and copy-turning with medium to large chip-cross-section
- special chipbreaker for controlled chip breaking
- machining of aluminum and aluminium alloys, non-ferrous metals as well as titanium and titanium alloys

Geometria ACB

- inserto di scanalatura rettificato periferico
- due taglienti
- superficie lappata
- scanalatura e tornitura di sezioni di truciolo medie e grandi
- rompitruciolo speciale
- lavorazione dell'alluminio e sue leghe, metalli non ferrosi come titanio e sue leghe

**ACB1/ACB4-Geometrie**

- Spezielle Geometrien zur Felgenbearbeitung
- umfangsgeschliffener Schneideinsatz
- zweiseitig
- polierte Spanfläche
- Zerspanung von Alu und Alu-Legierungen

ACB1/ACB4 geometry

- Special geometries for machining aluminum rims
- completely ground insert
- two cutting edges
- polished surface
- machining of aluminum and aluminium alloys

Geometria ACB1/ACB4

- geometrie speciali per la lavorazione di cerchi in alluminio
- inserto di scanalatura rettificato periferico
- due taglienti
- superficie lappata
- lavorazione dell'alluminio e sue leghe

Beschichtet / Coated / Rivestito

AM27C

CVD-Mehrlagenbeschichtung

Bearbeitung von Stahl, Stahlguss mit mittleren bis hohen Schnittgeschwindigkeiten, mittleren bis großen Spanquerschnitten und wechselnden Schnitttiefen. Speziell einsetzbar für Stähle mit starker Verklebneigung. Einsatz im Schlicht- und mittleren Schruppbereich.

CVD-multilayer coating

Machining steel, cast steel as well as grey cast iron, at medium to high cutting speeds, medium to large chip-cross-sections and varying depths of cut. Used for finishing and medium roughing.

Rivestimento multistrato CVD

Lavorazione di acciaio, acciaio da fusione con velocità di taglio da medie ad elevate, sezioni di truciolo medie e larghe e profondità di taglio varie. Per finitura e media sgrassatura.

AM35C

CVD-Mehrlagenbeschichtung

Bearbeitung von Stahl, rostfreiem Stahl sowie Stahlguss bei mittleren bis großen Spanquerschnitten und mittleren bis geringen Schnittgeschwindigkeiten unter ungünstigen Bearbeitungsbedingungen und hohen Zähigkeitsanforderungen.

CVD-multilayer coating

Machining steel, stainless steel and cast steel, at medium to large chip-cross-sections and medium to low cutting speeds under unfavourable machining conditions where good toughness is required.

Rivestimento multistrato CVD

Lavorazione di acciaio inossidabile e acciaio da fusione per sezioni di taglio medie e grandi e velocità di taglio medie e basse. In condizioni di lavorazione non favorevoli quando è richiesta una buona tenacità.

AM350

CVD-Mehrlagenbeschichtung

Zur Bearbeitung von Stahl und Stahlguss mit hohen Schnittgeschwindigkeiten, mittleren bis hohen Spanquerschnitten und wechselnden Schnitttiefen. Verschleißfeste Sorte durch speziell aufeinander abgestimmtes Substrat und Beschichtung. Einsatz im Schlicht- und mittleren Schruppbereich.

CVD-multilayer coating

Grade with a good combination of wear resistance and toughness for turning steel, stainless steel as well as cast steel at medium chip-cross-sections and medium to high cutting speeds. Can also be used under unfavourable machining conditions. Special grade for stainless steel (austenitic).

Rivestimento multistrato CVD

Grado resistente all'usura, buona tenacità per la tornitura dell'acciaio, acciaio inossidabile, sezioni di taglio medie, velocità di taglio medie ed elevate, in condizioni di lavoro non favorevoli. Grado particolarmente adatto ad acciai austenitici ed acciai inossidabili.

AR27C

CVD-Mehrlagenbeschichtung

Bearbeitung von Stahl, Stahlguss, rostfreiem Stahl, Gusseisen mit Kugelgraphit sowie Grauguss mit hohen Schnittgeschwindigkeiten unter stabilen Bearbeitungsbedingungen.

CVD-multilayer coating

Machining of steel, stainless steel, spheroidal cast iron, cast steel and grey cast iron at high cutting speeds under stable machining conditions.

Rivestimento multistrato CVD

Lavorazione dell'acciaio, acciaio inossidabile, ghisa sferoidale, fusioni d'acciaio a velocità di taglio elevate in condizioni di taglio stabili.

Unbeschichtet / Uncoated / Non rivestito

AK10

Feinkorn-Hartmetall zur Bearbeitung von Gusswerkstoffen, Leicht- und Buntmetallen, hochschmelzenden Metallen und gehärteten Stählen bis 55 HRC. In Verbindung mit der Spanleitstufengeometrie-ACB besonders für das Stechdrehen von Al- und Cu-Legierungen zu empfehlen.

Submicron carbide grade for machining cast materials, light and non-ferrous materials, refractory metals, hardened steels up to 55 HRC. In connection with chipbreaker-ACB specially suitable for machining Al- and Cu-alloys.

Metallo duro submicrograna per la lavorazione di fusioni, leghe leggere e non ferrose, metalli refrattari, metalli temprati fino a 55 HRC. Abbinato al rompitrucciolo-ACB è specificamente adatto per la lavorazione leghe di alluminio e rame.

AP40

Bearbeitung von Stahl, Stahlguss und austenitischen Stählen mit mittleren bis niedrigen Schnittgeschwindigkeiten, mittleren bis großen Spanquerschnitten, auch unter ungünstigen Bedingungen.

Machining of steel, cast steel and austenitic steel, at medium to lower cutting speeds, medium to large chip-cross-sections, also under unfavourable conditions.

Lavorazione d'acciaio, fusioni, acciai austenitici a velocità di taglio medie e basse, sezioni di taglio medie e grandi, anche in condizioni difficili.

Grade description

Descrizione delle Qualità

Beschichtet / Coated / Rivestito**AN8020 (PKD/PCD)**

Bearbeitung von NE-Metallen, Aluminiumlegierungen mit Siliziumanteilen, glas- und kohlefaserverstärkte Kunststoffe, Kugelgraphitguss bei hohen Schnittdaten. Durch die scharfe Schneidkante entstehen geringe Schnittdrücke und sehr gute Oberflächengüten bei extrem hoher Wärmeleitfähigkeit. Fein- und Feinstbearbeitung bei glattem und unterbrochenem Schnitt.

Machining of non-ferrous metals, aluminium alloys with silicon, glass- and coal-fiber reinforced materials, spheroidal cast iron, at high cutting speeds. Sharp cutting edges enable low cutting forces and extremely good surface finish. Finishing and super finishing even at interrupted cuts.

Lavorazione dei metalli non ferrosi, leghe d'alluminio con basso tenore di Silicio, materiali rinforzati al vetro e fibre di carbonio, a velocità di taglio elevate. Il tagliente affilato rende possibile bassi sforzi di taglio ed una finitura superficiale estremamente buona. Finitura e super finitura anche con taglio interrotto.

Radial-Stechedrehen / Radial groove turning / Scanalatura radiale

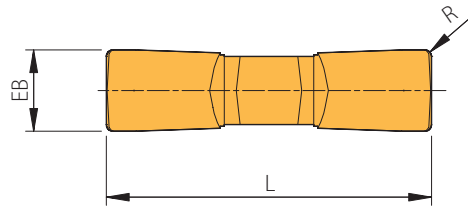
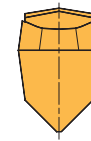
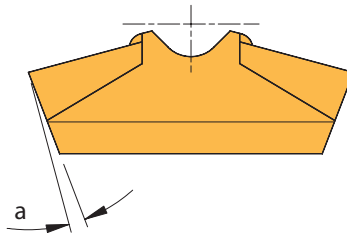

Gesinterte Ausführung / Sintered Execution / Esecuzione Sinterizzato

4

Bezeichnung Designation Articolo	EB ± 0,05	L	α	R	PG 15				beschichtet coated rivestito		unbeschichtet uncoated non rivestito	
					AM27C	AM35C	AM350	AR27C	AK10	AP40		
LOMX 120202EN	2,1	12	6°	0,2			●					
LOMX 150302EN	3,1	15	6°	0,2	●	●	●	●	●	●		
LOMX 180404EN	4,1	18	6°	0,4	●	●	●	●	●	●		
LOMX 200504EN	5,1	20	6°	0,4	●	●	●	●	●	●		
LOMX 200508EN	5,1	20	6°	0,8	●	●	●	●	●	●		
LOMX 240608EN	6,1	24	6°	0,8	●	●	●	●	●	●		

P	●	●	○	○		●
M	○	○	●	○		
K				●	●	
N					●	
S	○	○	○	○	○	
H				○		

● Hauptanwendung
Main application
Applicazione principale
○ Nebenanwendung
Secondary application
Applicazione secondaria

Radial-Stechedrehen / Radial groove turning / Scanalatura radiale

Präzisionsgeschliffene Ausführung / Precision ground execution / Esecuzione rettifica di precisione

						PG 15	
						unbeschichtet uncoated non rivestito	PKD
Bezeichnung Designation Articolo	EB ± 0,05	L	α	R	AK10	AN8020	
LOMX 320800FN	8	32	6°	4		●	
LOMX 320800FN-AEC	8	32	6°	4	●		
LOMX 320800TN-ALU	8	32	6°	4		●	

P		
M		
K	●	
N	●	●
S	○	○
H		○

- Hauptanwendung
Main application
Applicazione principale
- Nebenanwendung
Secondary application
Applicazione secondaria



Stechdrehen AM-Geometrie / Groove turning AM-geometry /
Scanalatura geometria AM

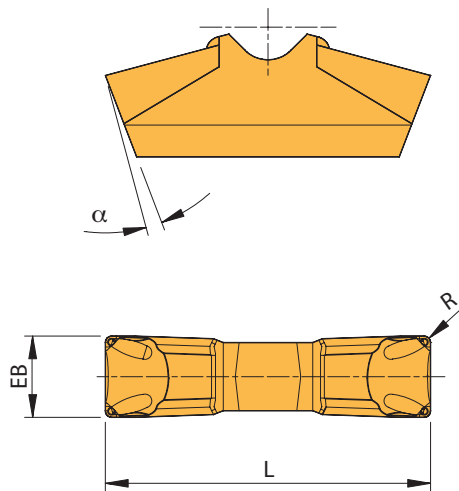

Gesinterte Ausführung / Sintered Execution / Esecuzione Sinterizzato

4

					PG 15		
					beschichtet coated rivestito		unbeschichtet uncoated non rivestito
Bezeichnung Designation Articolo	EB ± 0,05	L	α	R	AM27C	AM350	AK10
LOMX 150302EN-AM	3,1	15	6°	0,2	●	●	
LOMX 150304EN-AM	3,1	15	6°	0,2		●	
LOMX 180402EN-AM	4,1	18	6°	0,2		●	
LOMX 180404EN-AM	4,1	18	6°	0,4	●	●	
LOMX 200504EN-AM	5,1	20	6°	0,4	●	●	
LOMX 240608EN-AM	5,1	24	6°	0,8	●	●	
LOMX 320800FN-AMF	8,0	32	6°	4,0			●
LOMX 320808EN-AM	8,1	32	6°	0,8	●	●	
LOMX 401008EN-AM	10,1	40	6°	0,8		●	

P	●	○	
M	○	●	
K			●
N			●
S	○	○	○
H			

● Hauptanwendung
Main application
Applicazione principale
○ Nebenanwendung
Secondary application
Applicazione secondaria

Inserts
Inserti

Stechdrehen ACB-Geometrie / Groove turning ACB-geometry /
Scanalatura geometria ACB

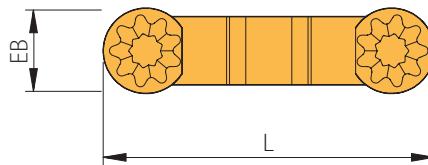
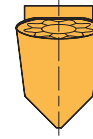
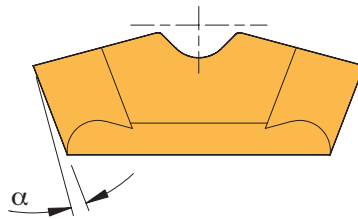

Präzisionsgeschliffene Ausführung / Precision ground execution / Esecuzione rettifica di precisione

						PG 15	
						unbeschichtet uncoated non rivestito	PKD
Bezeichnung Designation Articolo	EB ± 0,02	L ± 0,18	α	R	AK10*	AN8020	
LOMX 240600FN-ACB	6	24	6°	3	●	●	●
LOMX 320800EN-ACB1	8	32	6°	4			●
LOMX 320800FN-ACB	8	32	6°	4	●		
LOMX 320800TN-ACB	8	32	6°	4			●
LOMX 320800TN-ACB4	8	32	6°	4			●

Achtung: Halter ist für Vollradius-Schneideinsatz nachzuarbeiten!
 Achtung: Halter ist für Vollradius-Schneideinsatz nachzuarbeiten!
 Achtung: Halter ist für Vollradius-Schneideinsatz nachzuarbeiten!

Hinweis: AN8020 sind einseitig bestückte Schneideinsätze mit einem Spanwinkel von 0°.
 Remark: AN8020 inserts are single-sided with a rake angle of 0°.
 Nota: Gli inserti AN8020 hanno un solo tagliente con un angolo di taglio di 0°.

* Feinkorn-Hartmetall
 * Submicron carbide grad
 * Grado di carburo submicrograna

P		
M		
K	●	
N	●	●
S	○	○
H		○

● **Hauptanwendung**
 Main application
 Applicazione principale
 ○ **Nebenanwendung**
 Secondary application
 Applicazione secondaria



Spare parts and accessories
Ricambi e accessori

Artikel / Item / Articolo	PG 14
Klemme / Clamp / Staffa	
KTC3R	●
KTC3L	●
KTC4R	●
KTC4L	●
KTC5R	●
KTC5L	●
KTC6R	●
KTC6L	●
KTC8R	●
KTC8L	●
KTC10R	●
KTC10L	●
KTC6 R-ALU	●
KTC6 L-ALU	●
KTC8R-ALU	●
KTC8L-ALU	●
KTC2 R-10A	●
KTC3 R-12A	●
KTC4 R-16A	●
KTC5 R-16A	●
KTC6 R-16A	●

Artikel / Item / Articolo	PG 11
Klemmlagerstift / Clamping pin / Spina staffa	
DIN6325-3M6X10	●
DIN6325-3M6X12	●
DIN6325-3M6X14	●
DIN6325-4M6X14	●
STC1N	●
STC2N	●
STC4N	●

Artikel / Item / Articolo	PG 11
Schraube / Screw / Vite	
GTC6N	●
DIN912-M3x10-12.9	●
DIN912-M4x16-12.9	●
DIN912-M4x10-12.9	●

Artikel / Item / Articolo	PG 11
Anlagestift / Support pin / Spina di fermo	
ATC1N	●
ATC2N	●

Artikel / Item / Articolo	PG 11
Schlüssel / Key / Chiave	
KP 1111	●
KP 3421	●
KP 1321	●

Artikel / Item / Articolo	PG 11
Druckfeder / Compressing spring / Molla di compressione	
D-0900	●

Artikel / Item / Articolo	PG 11
Verschlussring / Locking ring / Anello di tenuta	
KVR 20	●
KVR 25	●
KVR 32	●
KVR 40	●

4

ARNO®

WERKZEUGE

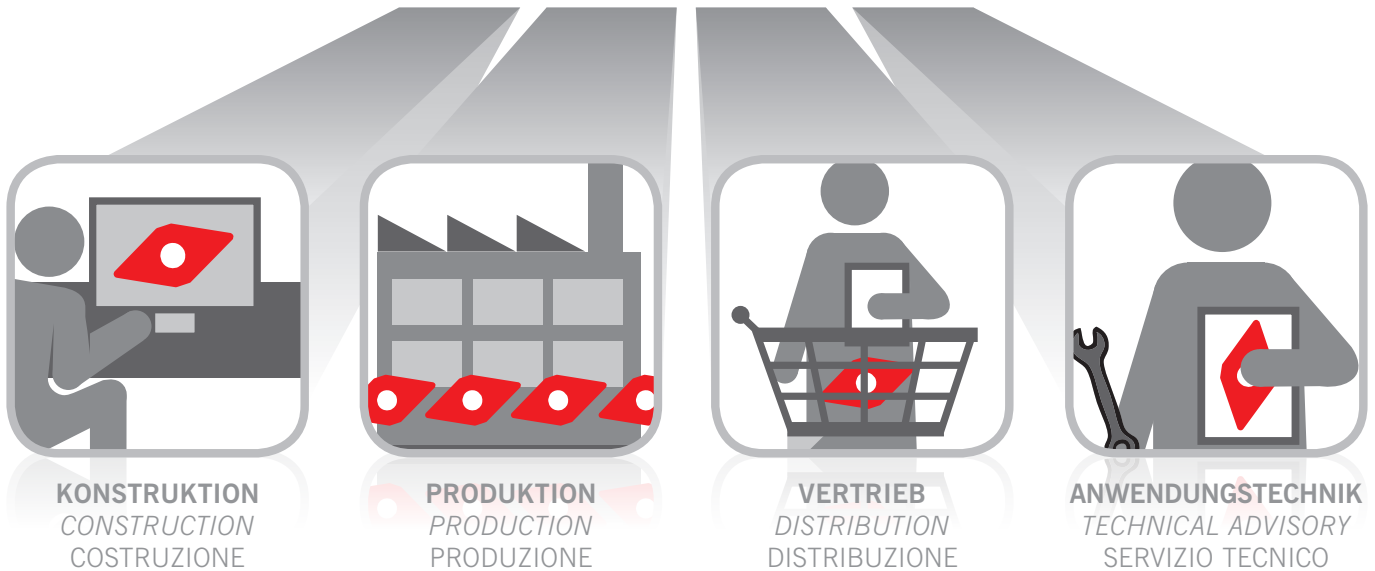

Schnell, flexibel und individuell.

Quick, flexible and individual.

Veloce, flessibile e individuale.

Konstruktion, Produktion und Vertrieb unter einem Dach.

Das ist die perfekte Verbindung um Ihnen Standard- und Sonderprodukte schnell und hochwertig anbieten zu können.

95% der Standardprodukte sind sofort verfügbar: Bei Bestellung bis 18 Uhr erhalten Sie Ihre Produkte bereits am nächsten Tag.

Mit großer fachlicher Kompetenz betreut Sie unser Außendienst-Team, unsere Anwendungstechniker helfen Ihnen mit Spezial-Wissen gerne auch vor Ort.

To have design, production and service all under one roof

is the perfect way of providing standard and special products.

95% of the standard programme is available from stock. Order received before 18.00 CET are dispatched the very same day and in most cases supplied next day.

Our competent team of technical sales engineers will be available to support you on site.

Costruzione, Produzione e Distribuzione sotto un unico tetto.

La sequenza perfetta per garantire un servizio di supporto cliente su prodotti Standard e Speciali di alta qualità.

Il 95% dei prodotti Standard sono disponibili a stock; con ordini entro le 18:00 garantiamo la consegna il giorno successivo.

Il nostro team di vendita altamente qualificato si offre come supporto alla produzione presso i nostri clienti direttamente sul territorio.

Weitere Informationen finden Sie unter:

For more information see:

Altre informazioni su:

www.arno.de

Empfohlene Schnittwerte

Werkstoff- gruppe	Gliederung der Werkstoffhauptgruppen und Kennbuchstaben		Brinell-Härte	Zugfestigkeit (N/mm ²)	Zerspanungsgruppe	Schnittgeschwindigkeit V _c (m/min)			
						beschichtet			
						AM27C	AM35C	AM350	
P	Unlegierter Stahl	C ≤ 0,25 % geglüht	125	428	P1	110 - 150 - 190	60 - 100 - 140	110 - 130 - 150	
		C > 0,25 ... ≤ 0,55 % geglüht	190	639	P2	100 - 130 - 160	70 - 90 - 110	90 - 105 - 120	
		C > 0,25 ... ≤ 0,55 % vergütet	210	708	P3	110 - 150 - 190	60 - 100 - 140	110 - 130 - 150	
		C > 0,55 % geglüht	190	639	P4	100 - 130 - 160	70 - 90 - 110	90 - 105 - 120	
		C > 0,55 % vergütet	300	1013	P5	110 - 150 - 190	60 - 100 - 140	110 - 130 - 150	
		Automatenstahl (kurzspanend) geglüht	220	745	P6	130 - 175 - 220	70 - 85 - 100	130 - 155 - 180	
	Niedrig legierter Stahl	geglüht	175	591	P7	120 - 140 - 160	70 - 85 - 100	100 - 125 - 150	
		vergütet	300	1013	P8	120 - 140 - 160	70 - 85 - 100	100 - 125 - 150	
		vergütet	380	1282	P9	100 - 130 - 160	60 - 75 - 90	90 - 105 - 120	
		vergütet	430	1477	P10	120 - 135 - 150	60 - 70 - 80	90 - 120 - 150	
	Hochlegierter Stahl und hochlegierter Werkzeugstahl	geglüht	200	675	P11	90 - 105 - 120	60 - 70 - 80	70 - 95 - 120	
		gehärtet und angelassen	300	1013	P12	90 - 105 - 120	60 - 70 - 80	70 - 95 - 120	
		gehärtet und angelassen	400	1361	P13	140 - 195 - 250	90 - 105 - 120	110 - 145 - 180	
	Nichtrostender Stahl	ferritisch / martensitisch, geglüht	200	675	P14	120 - 135 - 150	60 - 85 - 90	60 - 75 - 90	
		martensitisch, vergütet	330	1114	P15	130 - 165 - 200	100 - 140 - 180	110 - 155 - 200	
M	Nichtrostender Stahl	austenitisch, abgeschreckt	200	675	M1	80 - 105 - 130	80 - 115 - 150	80 - 100 - 120	
		austenitisch, ausscheidungsgehärtet (PH)	300	1013	M2	65 - 80 - 100	50 - 70 - 90	55 - 80 - 100	
		austenitisch-ferritisch, Duplex	230	778	M3	-	-	-	
K	Temperguss	ferritisch	200	675	K1	-	-	-	
		perritisch	260	867	K2	-	-	-	
	Grauguss	niedrige Festigkeit	180	602	K3	-	-	-	
		hohe Festigkeit / austenitisch	245	825	K4	-	-	-	
	Gusseisen mit Kugelgraphit	ferritisch	155	518	K5	-	-	-	
		perritisch	265	885	K6	-	-	-	
GGV (CGI)		200	675	K7	-	-	-		
N	Aluminium-Knetlegierungen	nicht aushärtbar	30	-	N1	-	-	-	
		aushärtbar, ausgehärtet	100	343	N2	-	-	-	
		≤ 12 % Si, nicht aushärtbar	75	260	N3	-	-	-	
	Aluminium-Gusslegierungen	≤ 12 % Si, aushärtbar, ausgehärtet	90	314	N4	-	-	-	
		> 12 % Si, nicht aushärtbar	130	447	N5	-	-	-	
	Magnesiumlegierungen		70	250	N6	-	-	-	
	Kupfer und Kupferlegierungen (Bronze / Messing)	unlegiert, Elektrolytkupfer	100	343	N7	-	-	-	
		Messing, Bronze, Rotguss	90	314	N8	-	-	-	
		Cu-Legierung, kurzspanend	110	382	N9	-	-	-	
		hochfest, Ampco	300	1013	N10	-	-	-	
Nichtmetallische Werkstoffe	Thermoplaste (ohne abrasive Füllstoffe)	-	-	N11	-	-	-		
	Duroplaste (ohne abrasive Füllstoffe)	-	-	N12	-	-	-		
	Kunststoff glasfaserverstärkt GFRP	-	-	N13	-	-	-		
	Kunststoff kohlefaserverstärkt CFRP	-	-	N14	-	-	-		
	Kunststoff aramidfaserverstärkt AFRP	-	-	N15	-	-	-		
	Graphit (technisch)	80 Shore	-	N16	30 - 40 - 50	-	-		
S	Warmfeste Legierungen	Fe-Basis geglüht	200	675	S1	25 - 35 - 40	20 - 30 - 40	20 - 30 - 40	
		ausgehärtet	280	943	S2	10 - 20 - 30	20 - 25 - 30	20 - 25 - 30	
		geglüht	250	839	S3	10 - 15 - 20	-	-	
		Ni- oder Co-Basis ausgehärtet	350	1177	S4	10 - 15 - 20	-	-	
		gegossen	320	1076	S5	-	-	-	
	Titanlegierungen	Reintitan	200	675	S6	-	-	-	
		α- und β-Legierungen, ausgehärtet	375	1262	S7	-	-	-	
		β-Legierungen	410	1396	S8	-	-	-	
	Wolframlegierungen		300	1013	S9	-	-	-	
	Molybdänlegierungen		300	1013	S10	-	-	-	
H	Gehärteter Stahl	gehärtet und angelassen	50 HRC	-	H1	-	-	-	
		gehärtet und angelassen	55 HRC	-	H2	-	-	-	
		gehärtet und angelassen	60 HRC	-	H3	-	-	-	
	Gehärtetes Gusseisen	gehärtet und angelassen	55 HRC	-	H4	-	-	-	

Die Tabellenwerte sind Richtwerte.
Es kann notwendig sein, die Werte den jeweiligen Bearbeitungsbedingungen anzupassen.

		unbeschichtet		PKD
	AR27C	AK10	AP40	AN8020
	160 - 220 - 280	-	90 - 105 - 120	-
	120 - 160 - 200	-	65 - 75 - 85	-
	100 - 115 - 130	-	50 - 60 - 70	-
	120 - 160 - 200	-	65 - 75 - 85	-
	100 - 115 - 130	-	50 - 60 - 70	-
	120 - 160 - 200	-	65 - 75 - 85	-
	150 - 190 - 230	-	70 - 85 - 100	-
	130 - 155 - 180	-	60 - 70 - 80	-
	130 - 155 - 180	-	60 - 70 - 80	-
	100 - 125 - 150	-	50 - 60 - 70	-
	140 - 155 - 170	-	50 - 60 - 70	-
	90 - 110 - 130	-	50 - 60 - 70	-
	90 - 110 - 130	-	50 - 60 - 70	-
	140 - 190 - 240	-	80 - 100 - 120	-
	60 - 80 - 100	-	60 - 80 - 100	-
	130 - 165 - 200	-	-	-
	80 - 105 - 130	-	-	-
	65 - 80 - 100	-	-	-
	150 - 180 - 210	100 - 150 - 200	-	-
	120 - 160 - 200	80 - 120 - 160	-	-
	130 - 175 - 220	120 - 140 - 160	-	-
	100 - 130 - 160	100 - 120 - 140	-	-
	160 - 195 - 230	90 - 120 - 150	-	-
	120 - 145 - 170	100 - 140 - 180	-	-
	150 - 180 - 210	100 - 150 - 200	-	-
	-	100 - 450 - 800	-	-
	-	80 - 440 - 800	-	350 - 1675 - 3000
	-	80 - 290 - 500	-	350 - 1675 - 3000
	-	-	-	350 - 1675 - 3000
	-	-	-	350 - 1675 - 3000
	-	-	-	-
	-	130 - 215 - 300	-	600 - 900 - 1200
	-	200 - 350 - 500	-	600 - 900 - 1200
	-	130 - 215 - 300	-	600 - 900 - 1200
	-	-	-	-
	-	100 - 300 - 500	-	600 - 900 - 1200
	-	100 - 300 - 500	-	600 - 900 - 1200
	-	80 - 115 - 150	-	80 - 790 - 1500
	-	80 - 115 - 150	-	80 - 790 - 1500
	-	80 - 115 - 150	-	80 - 790 - 1500
	-	-	-	-
	25 - 35 - 45	-	-	80 - 790 - 1500
	20 - 30 - 40	-	-	-
	15 - 20 - 25	-	-	-
	10 - 15 - 20	-	-	-
	10 - 15 - 20	-	-	-
	-	80 - 105 - 130	-	-
	-	40 - 55 - 70	-	60 - 70 - 80
	-	35 - 50 - 65	-	55 - 65 - 75
	-	-	-	-
	-	-	-	-
	-	-	-	-
	10 - 15 - 20	-	-	50 - 60 - 70
	-	-	-	-
	10 - 15 - 20	-	-	-



Recommended cutting data

Material group	Structure of the material groups and identification letters		Brinell hardness HB	Tensile strength Rm (N/mm ²)	Chipping group	Cutting speed V _c (m/min)			
						coated			
						AM27C	AM35C	AM350	
P	Unalloyed steel	C ≤ 0.25 % annealed	125	428	P1	110 - 150 - 190	60 - 100 - 140	110 - 130 - 150	
		C > 0.25 ... ≤ 0.55 % annealed	190	639	P2	100 - 130 - 160	70 - 90 - 110	90 - 105 - 120	
		C > 0.25 ... ≤ 0.55 % hardened and tempered	210	708	P3	110 - 150 - 190	60 - 100 - 140	110 - 130 - 150	
		C > 0.55 % annealed	190	639	P4	100 - 130 - 160	70 - 90 - 110	90 - 105 - 120	
		C > 0.55 % hardened and tempered	300	1013	P5	110 - 150 - 190	60 - 100 - 140	110 - 130 - 150	
		Machining steel (short-chipping) tempered	220	745	P6	130 - 175 - 220	70 - 85 - 100	130 - 155 - 180	
	Low alloyed steel	annealed	175	591	P7	120 - 140 - 160	70 - 85 - 100	100 - 125 - 150	
		hardened and tempered	300	1013	P8	120 - 140 - 160	70 - 85 - 100	100 - 125 - 150	
		hardened and tempered	380	1282	P9	100 - 130 - 160	60 - 75 - 90	90 - 105 - 120	
		hardened and tempered	430	1477	P10	120 - 135 - 150	60 - 70 - 80	90 - 120 - 150	
	High alloyed steel and high alloyed tool steel	annealed	200	675	P11	90 - 105 - 120	60 - 70 - 80	70 - 95 - 120	
		hardened	300	1013	P12	90 - 105 - 120	60 - 70 - 80	70 - 95 - 120	
		hardened	400	1361	P13	140 - 195 - 250	90 - 105 - 120	110 - 145 - 180	
	Stainless steel	ferritic / martensitic, annealed	200	675	P14	120 - 135 - 150	60 - 85 - 90	60 - 75 - 90	
		martensitic, hardened and tempered	330	1114	P15	130 - 165 - 200	100 - 140 - 180	110 - 155 - 200	
M	Stainless steel	austenitic, chilled	200	675	M1	80 - 105 - 130	80 - 115 - 150	80 - 100 - 120	
		austenitic, precipitation-hardened (PH)	300	1013	M2	65 - 80 - 100	50 - 70 - 90	55 - 80 - 100	
		austenitic-ferritic, Duplex	230	778	M3	-	-	-	
K	Malleable cast iron	ferritic	200	675	K1	-	-	-	
		pearlitic	260	867	K2	-	-	-	
	Cast iron	low tensile strength	180	602	K3	-	-	-	
		high tensile strength / austenitic	245	825	K4	-	-	-	
	Cast iron with nodular graphite	ferritic	155	518	K5	-	-	-	
		pearlitic	265	885	K6	-	-	-	
GGV (CGI)		200	675	K7	-	-	-		
N	Aluminium alloys long chipping	not heat treatable	30	-	N1	-	-	-	
		heat treatable, heat treated	100	343	N2	-	-	-	
		≤ 12 % Si, not heat treatable	75	260	N3	-	-	-	
	Casted aluminium alloys	≤ 12 % Si, aushärtbar, ausgehärtet	90	314	N4	-	-	-	
		> 12 % Si, not heat treatable	130	447	N5	-	-	-	
	Magnesium alloys		70	250	N6	-	-	-	
	Copper and copper alloys (Brass / Bronze)	Unalloyed, elektrolyte copper	100	343	N7	-	-	-	
		Brass, Bronze	90	314	N8	-	-	-	
		Cu-alloys, short-chipping	110	382	N9	-	-	-	
		High-tensile, Ampco	300	1013	N10	-	-	-	
Non-ferrous materials	Lead alloys (without abrasive filling material)	-	-	N11	-	-	-		
	Duroplastic (without abrasive filling material)	-	-	N12	-	-	-		
	Plastic glas fibre reinforced GFRP	-	-	N13	-	-	-		
	Plastic carbon fibre reinforced CFRP	-	-	N14	-	-	-		
	Plastic aramid fibre reinforced AFRP	-	-	N15	-	-	-		
	Graphite (tech.)		80 Shore	-	N16	30 - 40 - 50	-	-	
S	High temperature resistant alloys	Fe-Basis	annealed	200	675	S1	25 - 35 - 40	20 - 30 - 40	20 - 30 - 40
			heat treated	280	943	S2	10 - 20 - 30	20 - 25 - 30	20 - 25 - 30
		Ni- or Co-alloyed	annealed	250	839	S3	10 - 15 - 20	-	-
			heat treated	350	1177	S4	10 - 15 - 20	-	-
			casting	320	1076	S5	-	-	-
	Titanium alloys	Pure titan	200	675	S6	-	-	-	
		α- and β-alloys, heat treated	375	1262	S7	-	-	-	
		β-alloys	410	1396	S8	-	-	-	
	Wolfram alloys		300	1013	S9	-	-	-	
	Molybdän alloys		300	1013	S10	-	-	-	
H	Hardened steel	hardened	50 HRC	-	H1	-	-	-	
		hardened	55 HRC	-	H2	-	-	-	
		hardened	60 HRC	-	H3	-	-	-	
	Hardened cast iron	hardened	55 HRC	-	H4	-	-	-	

The recommended cutting data are only approximate values. It may be necessary to adjust them to each individual machining application.

		uncoated		PCD
	AR27C	AK10	AP40	AN8020
	160 - 220 - 280	-	90 - 105 - 120	-
	120 - 160 - 200	-	65 - 75 - 85	-
	100 - 115 - 130	-	50 - 60 - 70	-
	120 - 160 - 200	-	65 - 75 - 85	-
	100 - 115 - 130	-	50 - 60 - 70	-
	120 - 160 - 200	-	65 - 75 - 85	-
	150 - 190 - 230	-	70 - 85 - 100	-
	130 - 155 - 180	-	60 - 70 - 80	-
	130 - 155 - 180	-	60 - 70 - 80	-
	100 - 125 - 150	-	50 - 60 - 70	-
	140 - 155 - 170	-	50 - 60 - 70	-
	90 - 110 - 130	-	50 - 60 - 70	-
	90 - 110 - 130	-	50 - 60 - 70	-
	140 - 190 - 240	-	80 - 100 - 120	-
	60 - 80 - 100	-	60 - 80 - 100	-
	130 - 165 - 200	-	-	-
	80 - 105 - 130	-	-	-
	65 - 80 - 100	-	-	-
	150 - 180 - 210	100 - 150 - 200	-	-
	120 - 160 - 200	80 - 120 - 160	-	-
	130 - 175 - 220	120 - 140 - 160	-	-
	100 - 130 - 160	100 - 120 - 140	-	-
	160 - 195 - 230	90 - 120 - 150	-	-
	120 - 145 - 170	100 - 140 - 180	-	-
	150 - 180 - 210	100 - 150 - 200	-	-
	-	100 - 450 - 800	-	-
	-	80 - 440 - 800	-	350 - 1675 - 3000
	-	80 - 290 - 500	-	350 - 1675 - 3000
	-	-	-	350 - 1675 - 3000
	-	-	-	350 - 1675 - 3000
	-	-	-	-
	-	130 - 215 - 300	-	600 - 900 - 1200
	-	200 - 350 - 500	-	600 - 900 - 1200
	-	130 - 215 - 300	-	600 - 900 - 1200
	-	-	-	-
	-	100 - 300 - 500	-	600 - 900 - 1200
	-	100 - 300 - 500	-	600 - 900 - 1200
	-	80 - 115 - 150	-	80 - 790 - 1500
	-	80 - 115 - 150	-	80 - 790 - 1500
	-	80 - 115 - 150	-	80 - 790 - 1500
	-	-	-	-
	25 - 35 - 45	-	-	80 - 790 - 1500
	20 - 30 - 40	-	-	-
	15 - 20 - 25	-	-	-
	10 - 15 - 20	-	-	-
	10 - 15 - 20	-	-	-
	-	80 - 105 - 130	-	-
	-	40 - 55 - 70	-	60 - 70 - 80
	-	35 - 50 - 65	-	55 - 65 - 75
	-	-	-	-
	-	-	-	-
	-	-	-	-
	10 - 15 - 20	-	-	50 - 60 - 70
	-	-	-	-
	10 - 15 - 20	-	-	-



Parametri di taglio suggeriti

Gruppo materiale	Struttura dei gruppi di materiali e lettere di riferimento			Durezza Brinell	Resistenza Rm (N/mm ²)	Gruppo di lavoro	Velocità di taglio V _c (m/min)			
							rivestito			
							AM27C	AM35C	AM350	
P	Acciai non legato	C ≤ 0,25 %	ricotto	125	428	P1	110 - 150 - 190	60 - 100 - 140	110 - 130 - 150	
		C > 0,25 ... ≤ 0,55 %	ricotto	190	639	P2	100 - 130 - 160	70 - 90 - 110	90 - 105 - 120	
		C > 0,25 ... ≤ 0,55 %	bonificato	210	708	P3	110 - 150 - 190	60 - 100 - 140	110 - 130 - 150	
		C > 0,55 %	ricotto	190	639	P4	100 - 130 - 160	70 - 90 - 110	90 - 105 - 120	
		C > 0,55 %	bonificato	300	1013	P5	110 - 150 - 190	60 - 100 - 140	110 - 130 - 150	
	Acciai debolmente legati	Acciaio (truciolo corto)	ricotto	220	745	P6	130 - 175 - 220	70 - 85 - 100	130 - 155 - 180	
			ricotto	175	591	P7	120 - 140 - 160	70 - 85 - 100	100 - 125 - 150	
			bonificato	300	1013	P8	120 - 140 - 160	70 - 85 - 100	100 - 125 - 150	
			bonificato	380	1282	P9	100 - 130 - 160	60 - 75 - 90	90 - 105 - 120	
			bonificato	430	1477	P10	120 - 135 - 150	60 - 70 - 80	90 - 120 - 150	
	Acciai fortemente legati e acciai da utensili		ricotto	200	675	P11	90 - 105 - 120	60 - 70 - 80	70 - 95 - 120	
			temprato e rinvenuto	300	1013	P12	90 - 105 - 120	60 - 70 - 80	70 - 95 - 120	
			temprato e rinvenuto	400	1361	P13	140 - 195 - 250	90 - 105 - 120	110 - 145 - 180	
	Acciai inossidabili		ferritico / martensitico, ricotto	200	675	P14	120 - 135 - 150	60 - 85 - 90	60 - 75 - 90	
			martensitico, bonificato	330	1114	P15	130 - 165 - 200	100 - 140 - 180	110 - 155 - 200	
M	Acciai inossidabili		austenitico, trattato o temperato	200	675	M1	80 - 105 - 130	80 - 115 - 150	80 - 100 - 120	
			austenitico, indurimento per precipitazione (PH)	300	1013	M2	65 - 80 - 100	50 - 70 - 90	55 - 80 - 100	
			austenitico-ferritico, Duplex	230	778	M3	-	-	-	
K	Ghisa temprata		ferritico	200	675	K1	-	-	-	
			perlitica	260	867	K2	-	-	-	
	Ghisa grigia		bassa resistenza	180	602	K3	-	-	-	
			alta resistenza / austenitico	245	825	K4	-	-	-	
	Ghisa sferoidale		ferritico	155	518	K5	-	-	-	
			perlitica	265	885	K6	-	-	-	
	GGV (CGI)			200	675	K7	-	-	-	
N	Leghe di Alluminio stampato		non invecchiato	30	-	N1	-	-	-	
			rinvenuto, invecchiato	100	343	N2	-	-	-	
			≤ 12 % Si, non invecchiato	75	260	N3	-	-	-	
	Leghe di Alluminio da fusione		≤ 12 % Si, rinvenuto, invecchiato	90	314	N4	-	-	-	
			> 12 % Si, non invecchiato	130	447	N5	-	-	-	
		Leghe di magnesio			70	250	N6	-	-	-
	Rame e Leghe di Rame (Bronzo / Ottone)		Non legati, Rame Elettrolitico	100	343	N7	-	-	-	
			Ottone, Bronzo	90	314	N8	-	-	-	
			Leghe Cu, truciolo corto	110	382	N9	-	-	-	
			Alta resistenza, Ampco	300	1013	N10	-	-	-	
Materiali non metallici		Leghe al piombo (senza materiale di riempimento abrasivo)	-	-	N11	-	-	-		
		Duroplastico (senza materiale di riempimento abrasivo)	-	-	N12	-	-	-		
		Plastica rinforzata in fibra di vetro GFRP	-	-	N13	-	-	-		
		Plastica rinforzata in fibra di carbonio CFRP	-	-	N14	-	-	-		
		Plastica rinforzata in fibra aramidica AFRP	-	-	N15	-	-	-		
		Grafite (tecnico)			80 Shore	-	-	-		
S	Leghe resistenti al calore	Base-Fe	ricotto	200	675	S1	25 - 35 - 40	20 - 30 - 40	20 - 30 - 40	
			invecchiato	280	943	S2	10 - 20 - 30	20 - 25 - 30	20 - 25 - 30	
		Base Ni o Co	ricotto	250	839	S3	10 - 15 - 20	-	-	
			invecchiato	350	1177	S4	10 - 15 - 20	-	-	
			da fusione	320	1076	S5	-	-	-	
	Leghe di Titanio		Titanio puro	200	675	S6	-	-	-	
			Leghe α e β, invecchiato	375	1262	S7	-	-	-	
			Leghe β	410	1396	S8	-	-	-	
		Leghe di tungsteno			300	1013	S9	-	-	-
		Leghe di molibdeno			300	1013	S10	-	-	-
H	Acciaio Temprato		temprato e rinvenuto	50 HRC	-	H1	-	-	-	
			temprato e rinvenuto	55 HRC	-	H2	-	-	-	
			temprato e rinvenuto	60 HRC	-	H3	-	-	-	
		Ghisa Temprata			55 HRC	-	-	-		

I dati indicati in tabella sono valori approssimati. Può essere necessario adattarli alle singole applicazioni di lavorazione.

		non rivestito		PKD
	AR27C	AK10	AP40	AN8020
	160 - 220 - 280	-	90 - 105 - 120	-
	120 - 160 - 200	-	65 - 75 - 85	-
	100 - 115 - 130	-	50 - 60 - 70	-
	120 - 160 - 200	-	65 - 75 - 85	-
	100 - 115 - 130	-	50 - 60 - 70	-
	120 - 160 - 200	-	65 - 75 - 85	-
	150 - 190 - 230	-	70 - 85 - 100	-
	130 - 155 - 180	-	60 - 70 - 80	-
	130 - 155 - 180	-	60 - 70 - 80	-
	100 - 125 - 150	-	50 - 60 - 70	-
	140 - 155 - 170	-	50 - 60 - 70	-
	90 - 110 - 130	-	50 - 60 - 70	-
	90 - 110 - 130	-	50 - 60 - 70	-
	140 - 190 - 240	-	80 - 100 - 120	-
	60 - 80 - 100	-	60 - 80 - 100	-
	130 - 165 - 200	-	-	-
	80 - 105 - 130	-	-	-
	65 - 80 - 100	-	-	-
	150 - 180 - 210	100 - 150 - 200	-	-
	120 - 160 - 200	80 - 120 - 160	-	-
	130 - 175 - 220	120 - 140 - 160	-	-
	100 - 130 - 160	100 - 120 - 140	-	-
	160 - 195 - 230	90 - 120 - 150	-	-
	120 - 145 - 170	100 - 140 - 180	-	-
	150 - 180 - 210	100 - 150 - 200	-	-
	-	100 - 450 - 800	-	-
	-	80 - 440 - 800	-	350 - 1675 - 3000
	-	80 - 290 - 500	-	350 - 1675 - 3000
	-	-	-	350 - 1675 - 3000
	-	-	-	350 - 1675 - 3000
	-	-	-	-
	-	130 - 215 - 300	-	600 - 900 - 1200
	-	200 - 350 - 500	-	600 - 900 - 1200
	-	130 - 215 - 300	-	600 - 900 - 1200
	-	-	-	-
	-	100 - 300 - 500	-	600 - 900 - 1200
	-	100 - 300 - 500	-	600 - 900 - 1200
	-	80 - 115 - 150	-	80 - 790 - 1500
	-	80 - 115 - 150	-	80 - 790 - 1500
	-	80 - 115 - 150	-	80 - 790 - 1500
	-	-	-	-
	25 - 35 - 45	-	-	80 - 790 - 1500
	20 - 30 - 40	-	-	-
	15 - 20 - 25	-	-	-
	10 - 15 - 20	-	-	-
	10 - 15 - 20	-	-	-
	-	80 - 105 - 130	-	-
	-	40 - 55 - 70	-	60 - 70 - 80
	-	35 - 50 - 65	-	55 - 65 - 75
	-	-	-	-
	-	-	-	-
	-	-	-	-
	10 - 15 - 20	-	-	50 - 60 - 70
	-	-	-	-
	10 - 15 - 20	-	-	-

Recommended cutting data
Parametri di taglio suggeriti

Maximale Vorschübe und Spantiefen

Max. feed rate and depth of cut

Avanzamenti e profondità di taglio massimi

- f_v (mm/U) = **Vorschub ins Volle** / Feed rate into solid / Avanzamento nel pieno
- f_n (mm/U) = **Vorschub beim Einstechen** / Feed rate for re-grooving / Avanzamento di ripresa
- f_k (mm/U) = **Vorschub beim Kopieren** / Feed rate for copying / Avanzamento per copiatura
- a_p (mm) = **Spantiefe** / Depth of cut / Profondità di taglio

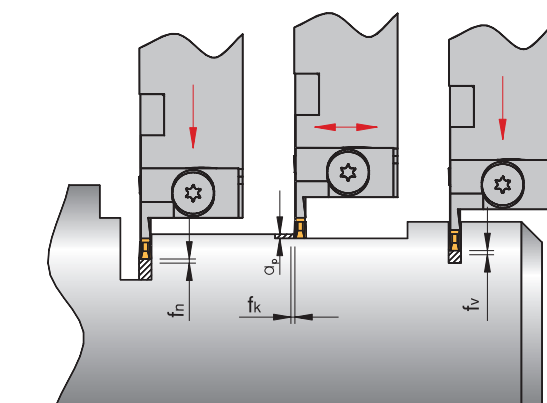

Stechdrehen / Groove turning / Scanalatura di copiatura

SHORT-CUT

	Schneideinsatz / Insert / Inserto				
	LOMX 120202 EN	LOMX 150302 EN	LOMX 180404 EN	LOMX 200504/08 EN	LOMX 240608 EN
f_v	0,04–0,15	0,08–0,15	0,10–0,25	0,10–0,25	0,10–0,30
f_n	0,04–0,15	0,08–0,15	0,10–0,30	0,10–0,35	0,10–0,40
f_k	0,04–0,10	0,08–0,15	0,10–0,25	0,10–0,25	0,10–0,30
a_p max	0,20–1,00	0,20–1,50	0,40–2,00	0,40–2,50	0,80–3,00

Stechdrehen / Groove turning / Scanalatura di copiatura

SHORT-CUT -AM

	Schneideinsatz / Insert / Inserto					
	LOMX 150302 EN-AM	LOMX 180404 EN-AM	LOMX 200504/08 EN-AM	LOMX 240608 EN-AM	LOMX 320808 EN-AM	LOMX 401008 EN-AM
f_v	0,08–0,15	0,10–0,25	0,10–0,30	0,10–0,30	0,10–0,35	0,10–0,35
f_n	0,08–0,15	0,10–0,30	0,10–0,35	0,10–0,40	0,10–0,40	0,10–0,40
f_k	0,08–0,20	0,10–0,30	0,10–0,30	0,10–0,35	0,10–0,35	0,10–0,35
a_p max	0,20–1,50	0,40–2,00	0,40–2,50	0,80–3,00	0,80–4,00	0,80–5,00

Stechdrehen / Groove turning / Scanalatura di copiatura

SHORT-CUT -ACB

	Schneideinsatz / Insert / Inserto	
	LOMX 240600 FN-ACB	LOMX 320800 FN-ACB
f_v	0,15–0,30	0,18–0,40
f_n	0,15–0,45	0,18–0,60
f_k	0,15–0,45	0,18–0,60
a_p max	3,00	4,00

Die Tabellenwerte sind Richtwerte. Es kann notwendig sein, die Werte den jeweiligen Bearbeitungsumständen anzupassen.
The recommended cutting data are only approximate values. It may be necessary to adjust them to each individual machining application.
I dati indicati in tabella sono valori approssimati. Può essere necessario adattarli alle singole applicazioni di lavorazione.



CLIP-GROOVE

CLIP-GROOVE

CLIP-GROOVE

Einteichsystem zum Außen- und Inneneinstechen

Grooving system for external and internal grooving

Sistema per scanalatura esterna e interna

• Systemvorstellung	• Introduction	• Caratteristiche del sistema	306 – 307
• Werkzeugauswahl	• Tool shank options	• Tipologie di corpo utensile	308
• Bezeichnungssystem	• Designation system	• Sistema di identificazione	309 – 310
• Monoblockhalter – Außeneinstechen	• Monoblock holders – External grooving	• Utensili monoblocco – di scanalatura esterna	311 – 313
• Bohrstangen – Inneneinstechen	• Boring bars – Internal grooving	• Barenì – di scanalatura interna	314
• Geometrie	• Geometry	• Geometria	315
• Sortenbeschreibung	• Grade description	• Descrizione delle Qualità	316 – 317
• Schneideinsätze	• Inserts	• Inserti	318 – 328
• Ersatzteile und Zubehör	• Spare parts and accessories	• Ricambi e accessori	329
• Schnittwerte	• Cutting data	• Parametri di taglio	330 – 335
• Anwendungshinweise	• Application reference	• Suggestimenti tecnici	336

Stechsystem mit dreischneidiger Schneidplatte für die radiale oder axiale Bearbeitung

Circlip grooving system for radial or axial application with 3-edged insert

Sistema di scanalatura con inserti a tre taglienti radiali o assiali

Monoblockhalter

Außeneinstecken

Monoblock holders

External grooving

Utensili monoblocco

di scanalatura esterna



Bohrstangen

Inneneinstecken

Boring bars

Internal grooving

Baren

di scanalatura interna



3-schneidige Schneideinsätze

3 edged inserts

Inserti a tre taglienti



5

Fakten

- **Drei Plattengrößen**
- **Einstechbreiten von 0,55 – 5 mm**
- **Einstechtiefe bis 10 mm**
- **Verschiedene Formeinstiche mit nur einem Werkzeug möglich**
- **Einsatzbereich:**
 - **Radiuseinstiche**
 - **Seegeringnuten DIN 471/472**
 - **Einstecken**
- **Optimaler Form- und Kraftschluss der Schneideinsätze durch Schraubenklemmung**
- **3-schneidige Schneideinsätze in verschiedenen Einstechbreiten**
- **Sonderprofile bis Stechbreite 7 mm möglich**
- **Schnelles Einspannen und Wechseln der Schneidplatten**
- **Clip-Groove® axial – speziell für Formeinstiche bei der Axialbearbeitung**

Features

- *Three insert sizes*
- *Groove width from 0.55 to 5 mm*
- *Groove depth up to 10 mm*
- *Choice of groove forms for the same tool holder*
- *Application areas*
 - *Radius grooves*
 - *Cir-clip grooves DIN 471/472*
 - *Straight grooves*
- *Optimum clamping and insert location with screw clamping*
- *3 edged inserts*
- *Special profiles possible up to 7 mm width*
- *Quick change of inserts*
- *Clip-Groove® axial for face grooving*

Caratteristiche

- Tre misure di inserti
- Larghezza di taglio 0,55 a 5 mm
- Profondità di gola max 10 mm
- Diverse forme di gole con il medesimo utensile
- Inserti profilati specifici per:
 - Gole raggiate
 - Sedi seeger DIN 471/472
 - Gole decimali
- Insetto perfettamente bloccato a vite
- Insetti a tre taglienti con diverse larghezze
- Possibili profili speciali fino ad una larghezza di 7 mm
- Cambio e serraggio inserto facile e veloce
- Versione Clip-Groove® – specifico per lavorazioni assiali

Tool shank options
Tipologie di corpo utensile

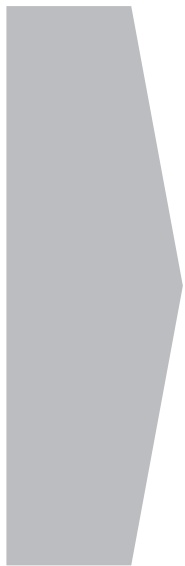

Monoblockhalter – Außeneinstecken / *Monoblock holders – External grooving* / *Utensili monoblocco di scanalatura esterna*

Seite/Page/Pagina **311 – 313**

5

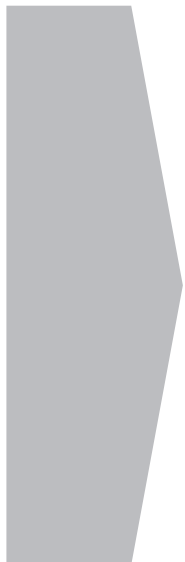

Bohrstangen – Inneneinstecken / *Boring bars – Internal grooving* / *Bareni di scanalatura interna*

Seite/Page/Pagina **314**



Schneideinsätze / *Inserts* / *Inserti*

Seite/Page/Pagina **318 – 328**

Monoblockhalter / Monoblock holders / Utensili monoblocco

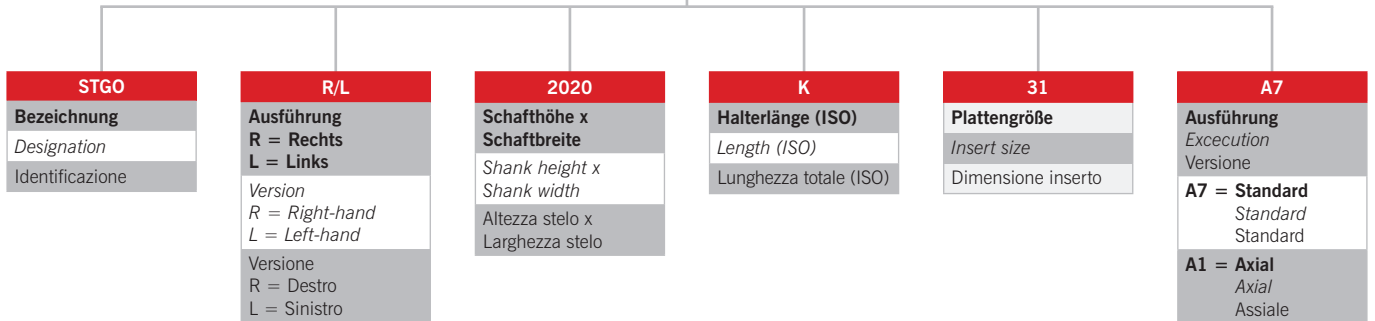

5

Bohrstangen / Boring bars / Barenì

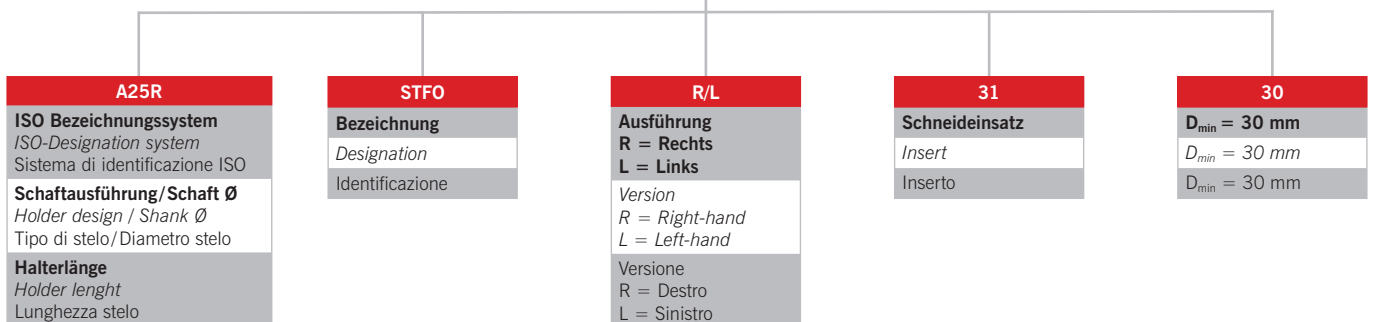

Schneideinsätze / Inserts / Inserti

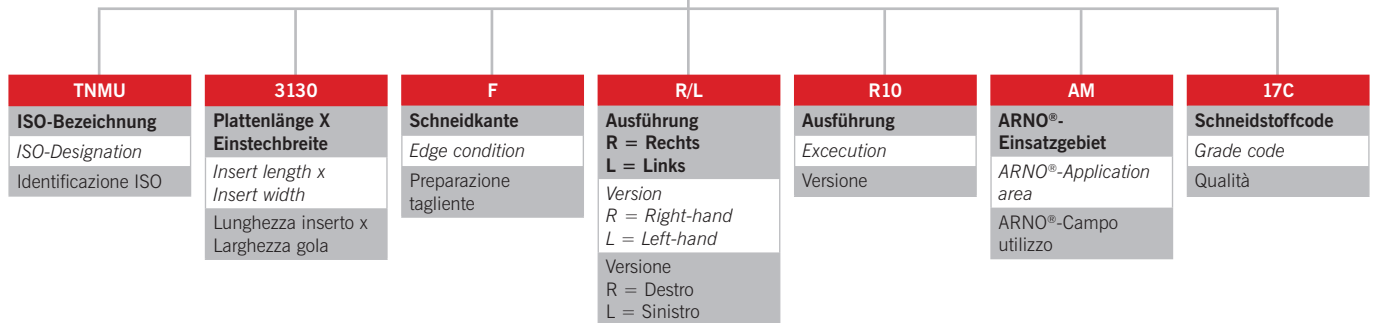

Radial-Steichen / Radial grooving / Scanalatura radiale

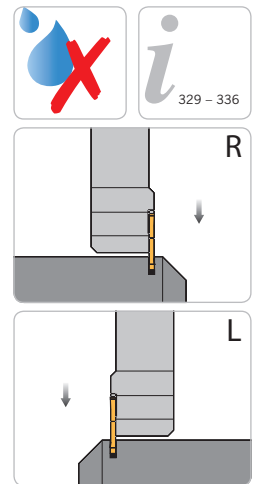
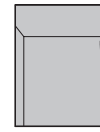
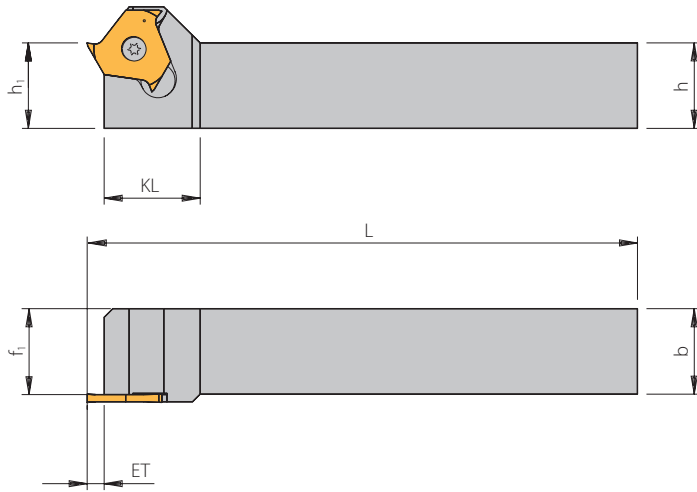

Rechte Ausführung abgebildet
Right-hand execution shown
Versione destra in figura

Trägerwerkzeuge / Holders / Utensili

Bezeichnung Designation Articolo	ET	h	b	L	f ₁	h ₁	KL	PG 12	Schneideinsatz Insert Inserto
STGOL/R 1010 E17-A7	2,0 ①	10	10	72,5	10,0	10	17,5	●	TNMU 17...
STGOL/R 1212 F17-A7	2,0 ①	12	12	82,5	12,0	12	17,5	●	TNMU 17...
STGOL/R 1616 J17-A7	2,0 ①	16	16	112,5	16,0	16	17,5	●	TNMU 17...
STGOL/R 1616 J17-A7/3 ②	2,0 ①	16	16	112,5	14,8	16	17,5	●	TNMU 17...
STGOL/R 2020 K17-A7	2,0 ①	20	20	127,5	20,0	20	17,5	●	TNMU 17...
STGOL/R 2020 K17-A7/3 ②	2,0 ①	20	20	127,5	18,8	20	17,5	●	TNMU 17...
STGOL/R 2525 M17-A7	2,0 ①	25	25	152,5	25,0	25	17,5	●	TNMU 17...
STGOL/R 2525 M17-A7/3 ②	2,0 ①	25	25	152,5	23,8	25	17,5	●	TNMU 17...
STGOL/R 1616 J31-A7	3,5 ②	16	16	114,0	16,0	16	22,5	●	TNMU 31...
STGOL/R 1616 J31-A7/4 ④	3,5 ②	16	16	114,0	13,8	16	22,5	●	TNMU 31...
STGOL/R 2020 K31-A7	3,5 ②	20	20	129,0	20,0	20	22,5	●	TNMU 31...
STGOL/R 2020 K31-A7/4 ④	3,5 ②	20	20	129,0	17,8	20	22,5	●	TNMU 31...
STGOL/R 2525 M31-A7	3,5 ②	25	25	154,0	25,0	25	22,5	●	TNMU 31...
STGOL 2525 M31-A7/4 ④	3,5 ②	25	25	154,0	22,8	25	22,5	●	TNMU 31...

- ① Bei Schneideinsätzen EB < 1,6 mm ist die Stechtiefe durch das Maß „t“ begrenzt.
Cutting depth is limited by the dimension "t" if cutting with EB < 1.6 mm for inserts.
Per gli inserti con EB < 1,6 mm, la profondità di taglio è limitata dalla quota "t".
- ② Bei Schneideinsätzen EB < 1,85 mm ist die Stechtiefe durch das Maß „t“ begrenzt.
Cutting depth is limited by the dimension "t" if cutting with EB < 1.85 mm for inserts.
Per gli inserti con EB < 1,85 mm, la profondità di taglio è limitata dalla quota "t".
- ③ Für die Halter STGO R/L.../3 Schneideinsätze TNMU 1730F R/L, TNMU 1731F R/L, TNMU 1735F R/L und TNMU 1740F R/L verwenden!
For the toolholder STGO R/L.../3 inserts TNMU 1730F R/L, TNMU 1731F R/L, TNMU 1735F R/L and TNMU 1740F R/L must be used!
Per l'utensile STGO R/L.../3 utilizzare gli inserti TNMU 1730F R/L, TNMU 1731F R/L, TNMU 1735F R/L e TNMU 1740F R/L!
- ④ Für die Halter STGO R/L.../4 Schneideinsätze TNMU 3140F R/L, TNMU 3145F R/L and TNMU 3150F R/L verwenden!
For the toolholder STGO R/L.../4 inserts TNMU 3140F R/L, TNMU 3145F R/L and TNMU 3150F R/L must be used!
Per l'utensile STGO R/L.../4 utilizzare gli inserti TNMU 3140F R/L, TNMU 3145F R/L e TNMU 3150F R/L!

Hinweis: Werkzeugsystem auch für Sonderprofile bis Stechbreite 7 mm geeignet.
Remark: Our tool-system can also be used for special profiles up to grooving width 7 mm.
Nota: Il nostro sistema può essere utilizzato per dei profili speciali fino ad una larghezza di scanalatura di 7 mm.

Hinweis: Zum Schulterdrehen Schraube AS0002 verwenden. (Seite 336)
Remark: When turning up to a shoulder use screw AS 0002. (Page 336)
Nota: In caso una elaborazione della superficie frontale dovete utilizzare la vite per il bloccaggio del inserto con il codice AS 0002. (Pagina 336)

Ersatzteile / Spare Parts / Ricambi

Trägerwerkzeug Holder Utensile	Schraube Screw Vite	Schlüssel Key Chiave
STGO L/R .. 17-..	AS 0007	KS 1751
STGO L/R .. 31-..	AS 0222	T5215-IP



Radial-Stechen (ET = 10mm) / Radial grooving (ET = 10mm) /
Scanalatura radiale (ET = 10mm)

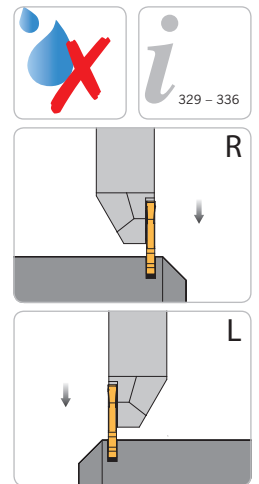
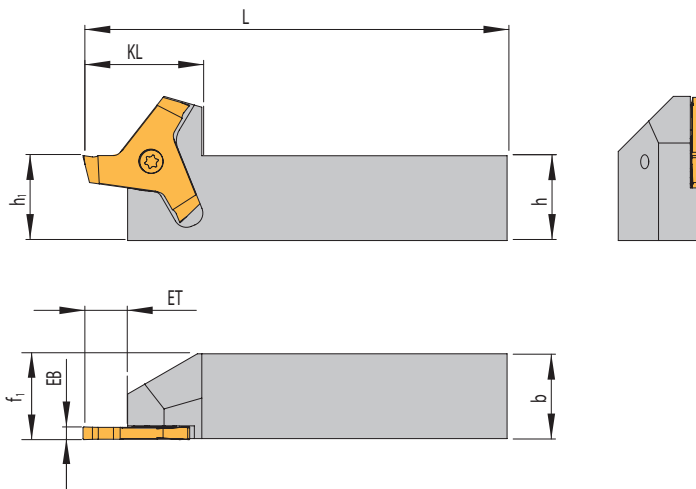

Rechte Ausführung abgebildet
Right-hand execution shown
Versione destra in figura

Trägerwerkzeuge / Holders / Utensili

Bezeichnung Designation Articolo	ET	h	b	L	f ₁	h ₁	KL	KT	PG 12	Schneideinsatz Insert Inserto
STGOL/R 1616 F31/2	10	16	16	85	16,25	16	28	30	●	TNMU31 10../ 15../ 20../ 25..
STGOL/R 1616 F31/3	10	16	16	85	16,25	16	28	30	●	TNMU31 30..
STGOL/R 1616 F31/4	10	16	16	85	16,25	16	28	30	●	TNMU31 40../ 50..
STGOL/R 2020 H31/2	10	20	20	100	20,25	20	28	34	●	TNMU31 10../ 15../ 20../ 25..
STGOL/R 2020 H31/3	10	20	20	100	20,25	20	28	34	●	TNMU31 30..
STGOL/R 2020 H31/4	10	20	20	100	20,25	20	28	34	●	TNMU31 40../ 50..
STGOL/R 2525 H31/2	10	25	25	125	25,25	25	28	39	●	TNMU31 10../ 15../ 20../ 25..
STGOL/R 2525 H31/3	10	25	25	125	25,25	25	28	39	●	TNMU31 30..
STGOL/R 2525 H31/4	10	25	25	125	25,25	25	28	39	●	TNMU31 40../ 50..

Ersatzteile / Spare Parts / Ricambi

Trägerwerkzeug Holder Utensile	Schraube Screw Vite	Schlüssel Key Chiave
STGO L/R.. 31..	AS 0222	T5215-IP

5

Axial Stechen / Axial grooving / Scanalatura assiale

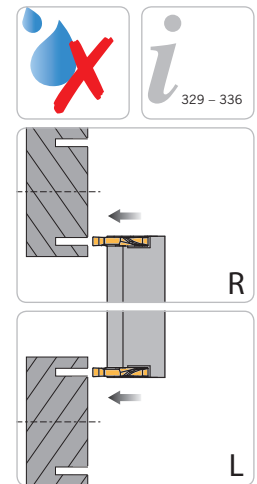
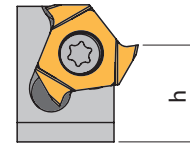
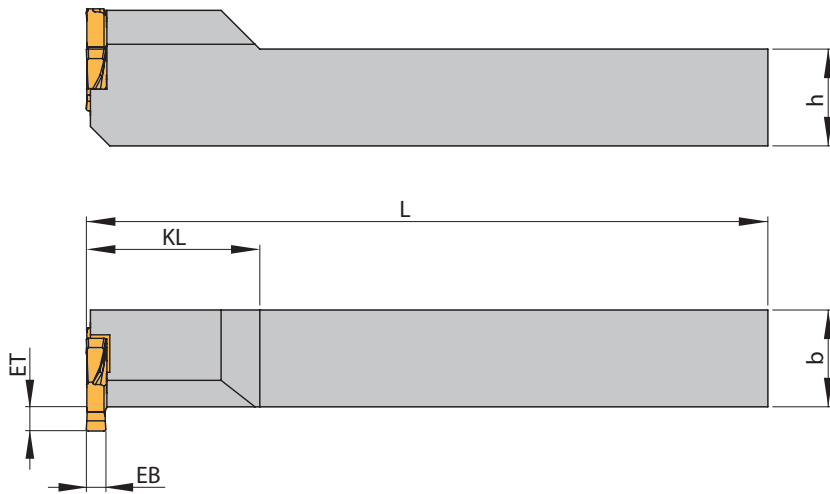

Rechte Ausführung abgebildet
Right-hand execution shown
Versione destra in figura

Trägerwerkzeuge / Holders / Utensili

Bezeichnung Designation Articolo	EB	ET	ET _{max}	D _{min}	h	b	L	KL	PG 12	Schneideinsatz Insert Inserto
STFOL/R 2020 K17-A1	1,0 - 2,0	1,5	2	10	20	20	125	17,5	●	TNMU 17...
STFOL/R 2020 K31-A1	1,5 - 2,5	2,0	3	20	20	20	125	22,5	●	TNMU 31...

Bitte beachten: Rechter Halter --> Linker Schneideinsatz, Linker Halter --> Rechter Schneideinsatz

Please note: Holder right-hand design --> Left-hand grooving insert, Holder left-hand design --> Right-hand grooving insert

Attenzione: portautensile destro --> inserto sinistro portautensile sinistro --> inserto destro

Ersatzteile / Spare Parts / Ricambi

Trägerwerkzeug Holder Utensile	Schraube Screw Vite	Schlüssel Key Chiave
STFO L/R .. 17-..	AS 0007	KS 1751
STFO L/R .. 31-..	AS 0222	T5215-IP

Innenstechdrehen / Internal groove turning / Scanalatura interna

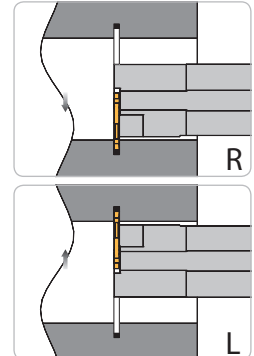
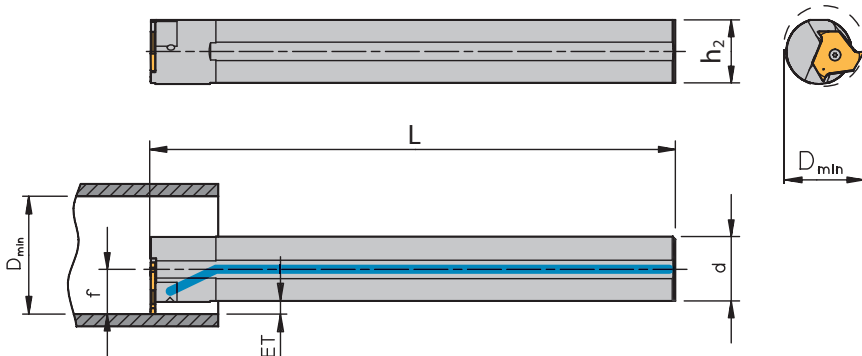

Rechte Ausführung abgebildet
Right-hand execution shown
Versione destra in figura

Trägerwerkzeuge / Holders / Utensili

Bezeichnung Designation Articolo	ET	D _{min}	d	h ₂	L	f	PG 12	Schneideinsatz Insert Inserto
A12K STFOL/R 1716 ⑥	2 ①	16	12	11	127	8,5	●	TNMU 17...
A12K STFOL/R 1716/3 ⑥	2 ①	16	12	11	128	8,5	●	TNMU 17...
A16M STFOL/R 1716	2 ①	16	16	15	152	8,5	●	TNMU 17...
A16M STFOL/R 1716/3 ⑥	2 ①	16	16	15	153	8,5	●	TNMU 17...
A20Q STFOL/R 1716	2 ①	16	20	19	182	8,5	●	TNMU 17...
A20Q STFOL/R 1725	2 ①	23	20	19	182	12,5	●	TNMU 17...
A20Q STFOL/R 1725/3 ⑥	2 ①	23	20	19	183	12,5	●	TNMU 17...
A25R STFOL/R 3130	4 ②	30	25	24	202	17,0	●	TNMU 31...
A25R STFOL/R 3130/4 ④	4 ②	30	25	24	204	17,0	●	TNMU 31...
A32S STFOL/R 3137	4 ②	37	32	30	252	20,5	●	TNMU 31...
A32S STFOL 3137/4 ④	4 ②	37	32	30	254	20,5	●	TNMU 31...

- ① Bei Schneideinsätzen EB < 1,6 mm ist die Stechtiefe durch das Maß „t“ begrenzt.
Cutting depth is limited by the dimension "t" if cutting with EB < 1.6 mm for inserts.
Per gli inserti con EB < 1,6 mm, la profondità di taglio è limitata dalla quota "t".
- ② Bei Schneideinsätzen EB < 1,85 mm ist die Stechtiefe durch das Maß „t“ begrenzt.
Cutting depth is limited by the dimension "t" if cutting with EB < 1.85 mm for inserts.
Per gli inserti con EB < 1,85 mm, la profondità di taglio è limitata dalla quota "t".
- ③ Für die Halter STFO R/L.../3 Schneideinsätze TNMU 1730F R/L, TNMU 1731F R/L, TNMU 1735F R/L und TNMU 1740F R/L verwenden!
For the toolholder STFO R/L.../3 inserts TNMU 1730F R/L, TNMU 1731F R/L, TNMU 1735F R/L and TNMU 1740F R/L must be used!
Per l'utensile STFO R/L.../3 utilizzare gli inserti TNMU 1730F R/L, TNMU 1731F R/L, TNMU 1735F R/L e TNMU 1740F R/L!
- ④ Für die Halter STFO R/L.../4 Schneideinsätze TNMU 3140F R/L, TNMU 3145F R/L und TNMU 3150F R/L verwenden!
For the toolholder STFO R/L.../4 inserts TNMU 3140F R/L, TNMU 3145F R/L and TNMU 3150F R/L must be used!
Per l'utensile STFO R/L.../4 utilizzare gli inserti TNMU 3140F R/L, TNMU 3145F R/L e TNMU 3150F R/L!
- ⑤ Nur bis Stechbreite EB = 2 mm
Only up to range of width EB = 2 mm
Solo da una larghezza di taglio EB = 2 mm

Hinweis: Bei Halter für TNMU... Schneidkante 0,5 mm über Mitte.
Remark: With the support for the TNMU..., cutting edge 0.5 mm over centre.
Nota: Tutti i bareni per TNMU hanno tagliente 0,5 mm sopra il centro.

Bitte beachten: Rechter Halter -> Linker Schneideinsatz, Linker Halter -> Rechter Schneideinsatz
Please note: Holder right-hand-design -> Left-hand insert, Holder left-hand-design -> Right-hand insert
Nota: Adattatore destro -> inserto sinistro, adattatore sinistro -> inserto destro

Ersatzteile / Spare Parts / Ricambi

Trägerwerkzeug Holder Utensile	Schraube Screw Vite	Schlüssel Key Chiave
STFO L/R .. 17-..	AS 0007	KS 1751
STFO L/R .. 31-..	AS 0222	T5215-IP

- 3-schneidig geschliffener Schneideinsatz
- Schneideinsatz für die Innen- und Außenbearbeitung
- verschiedene Formeinstiche

- 3 edge ground insert
- for internal and external machining
- several forms

- inserto intercambiabile a 3 taglienti
- inserto per lavorazione interna ed esterna
- diversi tipi di profilo gole

TNMU 17



TNMU 31



TNMU Axial



Sehr schneidfreudige und stabile Geometrie

- Universell einsetzbar
- Geschliffene Ausführung

Soft cutting and stable geometry

- Wide application area
- Ground version

Geometria stabile dal taglio dolce

- Ampia area applicativa
- Versione rettificata



T1
Gepresste Spanleitstufe zur Verbesserung der Spanbildung

- Für Stahl- und Rostfreibearbeitung
- Universell einsetzbar – auch bei dünnwandigen Teilen

Sintered chipbreaker for improved swarf formation

- For steel and stainless steel
- Universal geometry machining, for thin-walled components

Geometria sinterizzata per una migliore formazione del truciolo

- Per acciaio e materiali inossidabili
- Utilizzo universale, anche per pezzi sottili



S1
Gepresste Spanleitstufe zur Verbesserung der Spanbildung

- Spezielle Geometrie für rostfreie Stähle
- „Problemlöser“ bei der Stahlzerspannung

Sintered chipbreaker for improved swarf formation

- Especially for stainless steel
- Problem solver for steel machining

Geometria sinterizzata per una migliore formazione del truciolo

- Geometria specifica per acciai inossidabili
- Il risolutore dei problemi nella lavorazione di acciaio

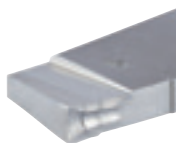

ALU
Hochpositive Geometrie mit scharfer Schneide

- Erste Wahl für Aluminium und NE-Metalle
- Umseitig geschliffener Schneideinsatz
- Polierte Spanflächen

High positive geometry with sharp cutting edge

- First choice for aluminium and non-ferrous materials
- Periphery ground insert
- High positive design
- Polished chip breakers

Geometria molto positiva con tagliente affilato

- Prima scelta per Alluminio e materiali non ferrosi
- Inserto rettificato e lappato
- Spoglia di taglio molto positiva

Beschichtet / Coated / Rivestito

AM17C

CVD-Mehrlagenbeschichtung
Feinkorn-Hartmetallsorte für den universellen Einsatz in sämtlichen Werkstoffen, wie z. B. Stahl, rostfreiem Stahl.

CVD-multilayer coating
Submicron carbide grade for universal application of all materials, e. g. steel, stainless steel, cast iron and non-ferrous materials.

Rivestimento multistrato CVD
Grado di carburo micrograna per un'applicazione universale su tutti i tipi di materiali come acciai legati, inossidabili, ghisa grigia e sferoidale.

AM5140

PVD-beschichtete Hartmetallsorte
Universell einsetzbare Sorte für mittlere Schnittgeschwindigkeiten. Hauptanwendungsbereich für rostfreie Stähle. In der weiteren Anwendung auch für Stahlwerkstoffe geeignet.

PVD coated carbide grade
Universally applied with medium cutting speeds. Main application area being stainless steel, this grade is also suitable for steel machining.

Qualità rivestita PVD
Applicazione universale molto tenace con medie velocità di taglio. Principale utilizzo su acciai inox ma idoneo anche per acciai.

AP5020

PVD-beschichtete Hartmetallsorte
Eine sehr universell einsetzbare Sorte für niedrige und mittlere Schnittgeschwindigkeiten. Hauptanwendungsbereich für Stahl. Als Nebenanwendung geeignet für die Bearbeitung rostfreier Stähle und für das Ein- und Abstechen hochwarmfester Werkstoffe und NE-Metalle.

PVD coated carbide grade
A versatile grade for low to medium cutting speeds. Main application area is steel but can also be used on stainless steel and both high temperature and non-ferrous materials.

Metallo duro rivestito PVD
Qualità universale per velocità di taglio medie. Adatto principalmente per acciaio e secondariamente per acciaio inossidabile. Utilizzo secondario anche per metalli non ferrosi e refrattari.

PVD1

PVD-Mehrlagenbeschichtung
Feinkorn-Hartmetallsorte mit hoher Verschleißfestigkeit und gutem Widerstand gegen plastische Verformung für die leichte bis mittlere Zerspanung. Speziell zur Zerspannung von NE-Metallen, wie z. B. Al und Al-Legierungen, Kupfer, Bronze und hochschmelzenden Werkstoffen.

PVD multilayer coating
Submicron carbide grade with high wear resistance and resistance against crater wear. Light to medium cutting. Excellent for machining non-ferrous products, e.g. aluminium and aluminium alloys, copper, brass and refractory metals.

Rivestimento multistrato PVD
Qualità con base sub-micrograna per una elevata resistenza all'usura ed alla caratterizzazione. Idonea alla finitura e semifinitura. Eccellente per la lavorazione di materiali non ferrosi come Alluminio, leghe di Alluminio, Rame, Ottone, Leghe refrattarie (Niobio, Tantalio, Molibdeno, Tungsteno) e Ghisa grigia.

PVD2

PVD-Mehrlagenbeschichtung
Verschleißfeste Sorte mit guter Schneidkanten-sicherheit zur Bearbeitung von Nichteisenmetallen, wie z. B. Al und Al-Legierungen, Kupfer, Bronze und hochschmelzenden Werkstoffen unter ungünstigen Bearbeitungsbedingungen. Auch geeignet für die Zerspannung von Stahl und rostfreiem Stahl im unteren Schlichtbereich bei guten Bearbeitungsbedingungen.

PVD-multilayer coating
Wear resistant grade with good cutting edge stability for machining non-ferrous materials, e. g. Al and Al-alloys, copper brass and refractory metals under unfavourable machining conditions. Also suitable for finishing steel and stainless steel under favourable machining conditions.

Rivestimento multistrato PVD
Grado di carburo resistente all'usura, buona tenuta del tagliente, per la lavorazione di metalli non ferrosi (p. e. alluminio, leghe d'alluminio, rame, bronzo) e materiali refrattari (p. e. niobio, tantalio, molibdeno, tungsteno), in condizioni di taglio non favorevoli. Anche adatto alla finitura dell'acciaio e dell'acciaio inossidabile in buone condizioni di taglio.

Unbeschichtet / Uncoated / Non rivestito

AK10

Feinkorn-Hartmetall zur Bearbeitung von Gusswerkstoffen, Leicht- und Buntmetallen, hochschmelzenden Metallen und gehärteten Stählen bis 55 HRC. In Verbindung mit der Spanleitstufengeometrie-ALU besonders für das Stechdrehen von Al- und Cu-Legierungen zu empfehlen.

Submicron carbide grade for machining cast materials, light and non-ferrous materials, refractory metals, hardened steels up to 55 HRC. In connection with chipbreaker-ALU specially suitable for machining Al- and Cu-alloys.

Grado submicrograna per la lavorazione di fusioni, leghe leggere e non ferrose, metalli refrattari, metalli temprati fino a 55 HRC. Abbinato al rompitrucciolo-ALU è specificamente adatto per la lavorazione leghe di alluminio e rame.

AK20

Hartmetallsorte mit höherer Zähigkeit zur Bearbeitung von Al und Al-Legierungen, Kupfer, Bronze, NE-Metalle und hochschmelzenden Werkstoffen bei mittleren Spanquerschnitten unter ungünstigen Bearbeitungsbedingungen, wie unterbrochene Schnitte.

A grade with great resilience for machining Al and Al-alloys, copper, brass, non-ferrous and refractory metals with medium chip cross sections under unfavourable machining conditions and interrupted cuts.

Un grado con grande resilienza per la lavorazione dell'Alluminio e sue leghe, ottone, rame, metalli non ferrosi e refrattari (p. e. niobio, tantalio, molibdeno, tungsteno) con sezioni di truciolo in condizioni di taglio non favorevoli e taglio interrotto.

AN1015

Unbeschichtete Hartmetallsorte zum Schlichten und Schruppen von Aluminiumlegierungen und bei NE-Metallen in Verbindung mit geschliffenen Schneidkanten. Zur Reduzierung der Aufbauschneidenbildung ist die Spanfläche hochglanzpoliert.

Uncoated carbide grade which in connection with a ground cutting edge is for finishing and roughing of aluminium alloys and non-ferrous materials. In order to reduce build up edge problems the insert is also highly polished.

Grado di metallo duro micrograna per tutte le lavorazioni di materiali non ferrosi e Alluminio. Tagliante rettificato super positivo e spoglia lappata per ridurre tagliante di riporto.

CERMET

Bearbeitung von Stahl, Stählen mittlerer Festigkeit sowie rostfreiem Stahl und Gusseisen mit Kugelgraphit. Bedingt einsetzbar für Grauguss.

Machining of steel, steels with medium tensile strength as well as stainless steel and spheroidal cast iron. Limited use on grey cast iron.

Lavorazione dell'acciaio, acciai di durezza media come l'acciaio inossidabile e la ghisa sferoidale. Uso limitato sulla ghisa grigia.

Inserts
Inserti

TNMU 17

Schneideinsätze für Seegeringnuten DIN 471/472 / Inserts for circlip grooves to DIN 471/472 / Inserti per gole sedi seeger DIN 471/472

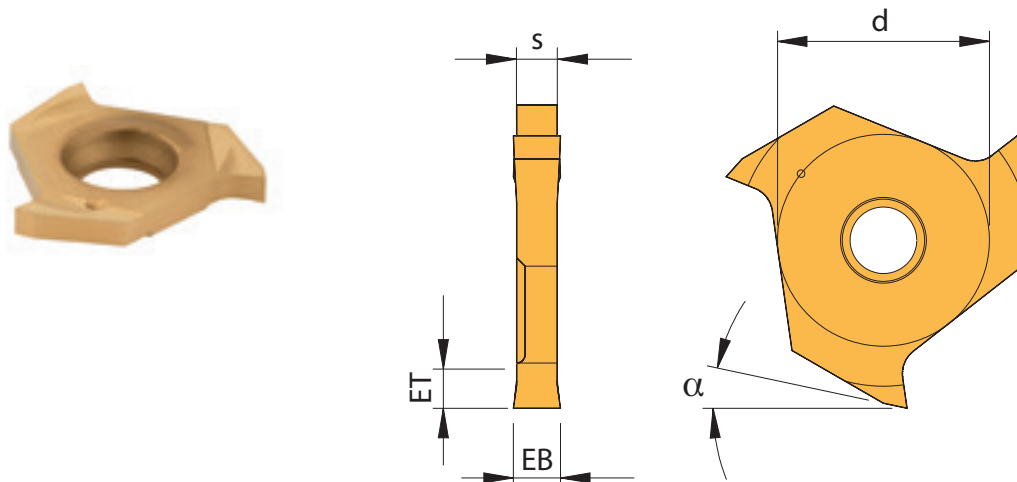

Präzisionsgeschliffene Ausführung / Precision ground execution / Esecuzione rettifica di precisione

5

Bezeichnung Designation Articolo	EB + 0,05	ET	d	s	α	beschichtet coated rivestito		PG 15 unbeschichtet uncoated non rivestito		
						AM17C	PVD2	AK10	AK20	CERMET
TNMU 1705FL/R	0,55	0,7	7,5	1,52	12°	●	●	●	●	
TNMU 1707FL/R	0,75	1,0	7,5	1,52	12°	●	●	●	●	
TNMU 1708FL/R	0,85	1,3	7,5	1,52	12°	●	●	●	●	
TNMU 1709FL/R	0,95	1,3	7,5	1,52	12°	●	●	●	●	
TNMU 1711FL/R	1,15	1,5	7,5	1,52	12°	●	●	●	●	
TNMU 1713FL/R	1,35	1,5	7,5	1,52	12°	●	●	●	●	
TNMU 1716FL/R	1,65	2,0	7,5	1,52	12°	●	●	●	●	
TNMU 1718FL/R	1,90	2,0	7,5	1,77	12°	●	●	●	●	
TNMU 1721FL/R	2,20	2,0	7,5	2,07	12°	●	●	●	●	●
TNMU 1726FL/R	2,70	2,0	7,5	2,57	12°	●	●	●	●	●
TNMU 1731FL/R	3,20	2,0	7,5	3,07	12°	●	●	●	●	●

P	●	○			●
M	●	○			○
K	○	○	●	●	○
N	○	●	●	●	
S	○	○	○	○	
H					

● Hauptanwendung
Main application
Applicazione principale
○ Nebenanwendung
Secondary application
Applicazione secondaria

Inserts
Inserti

TNMU 17

Schneideinsätze für Seegeringnuten nach DIN 471/472 Vollprofil / Inserts for circlip grooves to DIN 471/472 full profile / Inserti per gole sedi seeger DIN 471/472 profilo completo

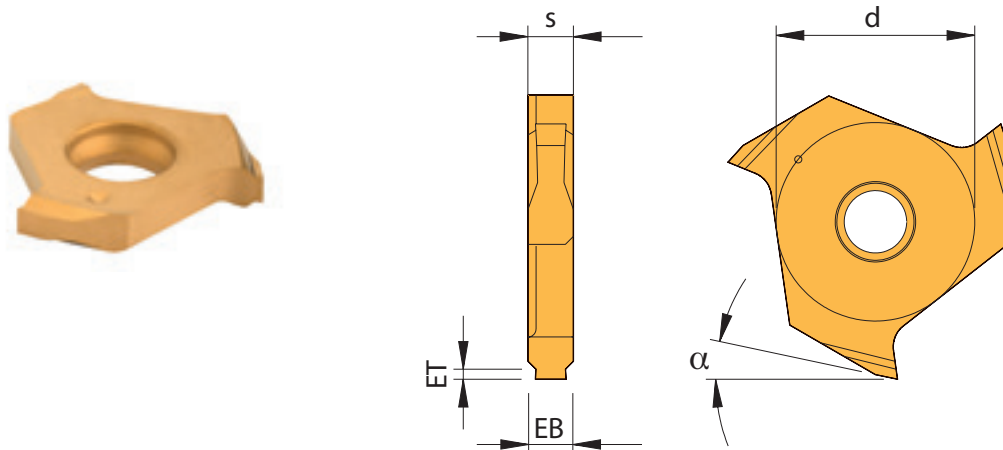

Präzisionsgeschliffene Ausführung / Precision ground execution / Esecuzione rettifica di precisione

						PG 15	
						beschichtet coated rivestito	unbeschichtet uncoated non rivestito
Bezeichnung Designation Articolo	EB + 0,05	ET	d	s	α	AM17C	AK10
TNMU 1711FL/R-V020	1,15	0,20	7,5	1,77	12°	●	●
TNMU 1711FL/R-V025	1,15	0,25	7,5	1,77	12°	●	●
TNMU 1711FL/R-V030	1,15	0,30	7,5	1,77	12°	●	●
TNMU 1711FL/R-V035	1,15	0,35	7,5	1,77	12°	●	●
TNMU 1711FL/R-V040	1,15	0,40	7,5	1,77	12°	●	●
TNMU 1713FL/R-V055	1,35	0,55	7,5	2,07	12°	●	●
TNMU 1716FL/R-V070	1,65	0,70	7,5	2,57	12°	●	●
TNMU 1716FL/R-V085	1,65	0,85	7,5	2,57	12°	●	●
TNMU 1716FL/R-V100	1,65	1,00	7,5	2,57	12°	●	●
TNMU 1718FL/R-V100	1,90	1,00	7,5	3,07	12°	●	●
TNMU 1718FL/R-V125	1,90	1,25	7,5	3,07	12°	●	●

P	●	
M	●	
K	○	●
N	○	●
S	○	○
H		

● Hauptanwendung
Main application
Applicazione principale

○ Nebenanwendung
Secondary application
Applicazione secondaria

5

Inserts
Inserti

TNMU 17

Schneideinsätze Vollradius / Full radius inserts / Inserti per gola a raggio completo

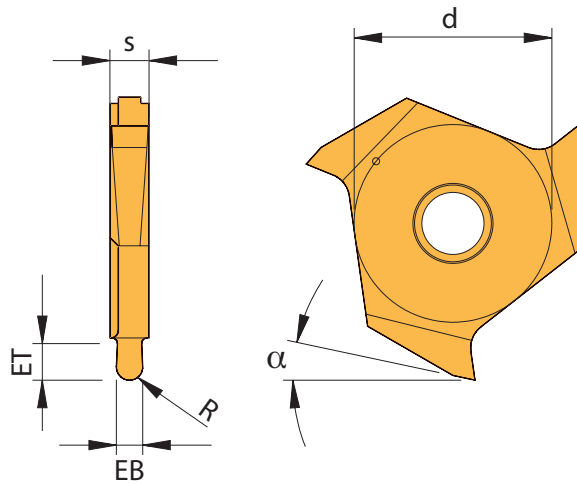

Präzisionsgeschliffene Ausführung / Precision ground execution / Esecuzione rettifica di precisione

5

Bezeichnung Designation Articolo	EB ± 0,02	R	ET	d	s	α	PG 15				
							beschichtet coated rivestito		unbeschichtet uncoated non rivestito		
							AM17C	PVD2	AK10	AK20	CERMET
TNMU 1710FL/R-R05	1	0,5	1,0	7,5	1,52	12°	●	●	●	●	
TNMU 1720FL/R-R10	2	1,0	1,5	7,5	2,57	12°	●	●	●	●	●

P	●	○			●
M	●	○			○
K	○	○	●	●	○
N	○	●	●	●	
S	○	○	○	○	
H					

● **Hauptanwendung**
Main application
Applicazione principale

○ **Nebenanwendung**
Secondary application
Applicazione secondaria

TNMU 17

Schneideinsätze Axial / Inserts Axial / Inserti per gole assiale

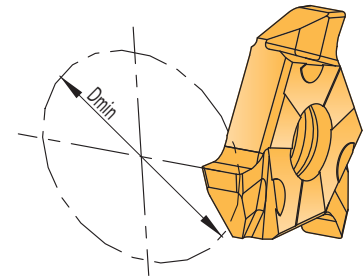
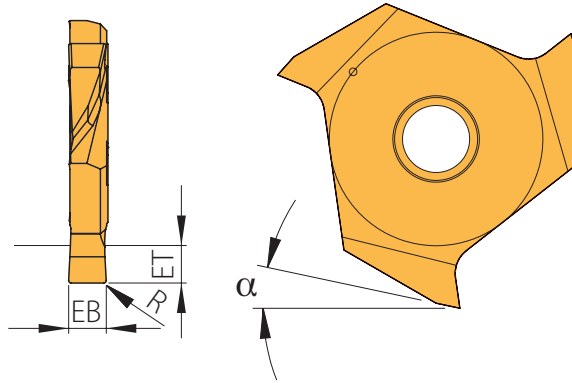

Präzisionsgeschliffene Ausführung / Precision ground execution / Esecuzione rettifica di precisione

Bezeichnung Designation Articolo	EB ± 0,02	R	ET	D _{min}	d	α	PG 15	
							beschichtet coated rivestito	unbeschichtet uncoated non rivestito
							PVD2	AK20
TNMU 1710FL/R-AX10	1,0	0,1	1,5	10	7,5	12°	●	●
TNMU 1715FL/R-AX10	1,5	0,1	2,0	10	0,0	12°	●	●
TNMU 1720FL/R-AX10	2,0	0,2	2,0	10	0,0	12°	●	●

P	○	
M	○	
K	○	●
N	●	●
S	○	○
H		

● Hauptanwendung
Main application
Applicazione principale
○ Nebenanwendung
Secondary application
Applicazione secondaria

5

Inserts
Inserti

TNMU 17

Schneideinsätze Geradmaße / Inserts with straight dimensions / Inserti per canali
dimensioni decimali

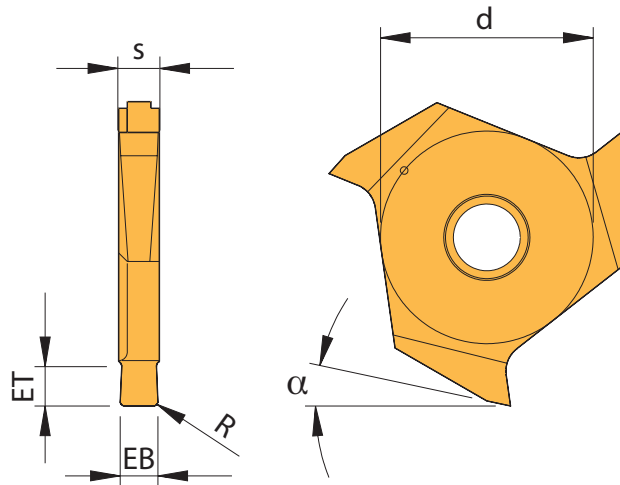

Präzisionsgeschliffene Ausführung / Precision ground execution / Esecuzione rettifica di precisione

5

Bezeichnung Designation Articolo	EB ± 0,02	R	ET	d	s	α	PG 15						
							beschichtet coated rivestito			unbeschichtet uncoated non rivestito			
							AM17C	PVD1	PVD2	AK10	AK20	CERMET	
TNMU 1710FR	1,0	0,1	1,8	7,5	1,77	12°		●			●		
TNMU 1715FL/R	1,5	0,1	1,8	7,5	1,77	12°	●		●	●	●	●	
TNMU 1720FL/R	2,0	0,1	1,8	7,5	2,07	12°	●		●	●	●	●	●
TNMU 1725FL/R	2,5	0,2	1,8	7,5	2,57	12°	●		●	●	●	●	●
TNMU 1730FL/R	3,0	0,2	1,8	7,5	3,07	12°	●		●	●	●	●	●
TNMU 1735FL/R	3,5	0,2	1,8	7,5	3,57	12°	●				●		
TNMU 1740FL/R	4,0	0,2	1,8	7,5	4,37	12°	●				●		

Hinweis: Ab Schneideinsatz TNMU 1730L/R den Halter STGOL/R.../3 verwenden!
Remark: For inserts TNMU 1730L/R the toolholder STGOL/R.../3 must be used!
Nota: Per gli inserti a partire da TNMU 1730L/R deve essere utilizzato il adattatore STGOL/R.../3!

	P	M	K	N	S	H
●	●	○	○			●
○	○	○	○			○
●	○	○	○	●	●	○
○	○	○	○	○	○	○
○	○	○	○	○	○	○

● Hauptanwendung
Main application
Applicazione principale
○ Nebenanwendung
Secondary application
Applicazione secondaria

Inserts
Inserti

TNMU 31

Schneideinsätze für Seegeringnuten DIN 471/472 / Inserts for circlip grooves to DIN 471/472 / Inserti per gole sedi seeger DIN 471/472

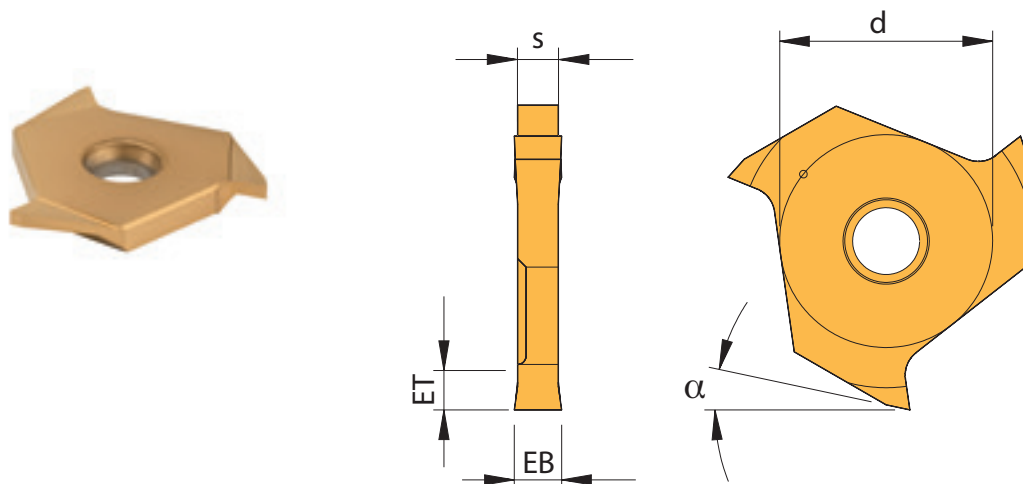

Präzisionsgeschliffene Ausführung / Precision ground execution / Esecuzione rettifica di precisione

Bezeichnung Designation Articolo	EB + 0,05	ET	d	s	α	PG 15				
						beschichtet coated rivestito		unbeschichtet uncoated non rivestito		
						AM17C	PVD2	AK10	AK20	CERMET
TNMU 3105FL/R	0,55	0,7	14	2,56	14°	●	●	●	●	
TNMU 3107FL/R	0,75	1,0	14	2,56	14°	●	●	●	●	
TNMU 3108FL/R	0,85	1,9	14	2,56	14°	●	●	●	●	
TNMU 3109FL/R	0,95	2,0	14	2,56	14°	●	●	●	●	
TNMU 3111FL/R	1,15	2,0	14	2,56	14°	●	●	●	●	
TNMU 3113FL/R	1,35	2,0	14	2,56	14°	●	●	●	●	
TNMU 3116FL/R	1,65	2,0	14	2,56	14°	●	●	●	●	
TNMU 3118FL/R	1,90	3,5	14	2,56	14°	●	●	●	●	
TNMU 3121FL/R	2,20	3,5	14	2,56	14°	●	●	●	●	●
TNMU 3126FL/R	2,70	3,5	14	2,56	14°	●	●	●	●	●
TNMU 3131FL/R	3,20	3,5	14	3,06	14°	●	●	●	●	●

P	●	○			●
M	●	○			○
K	○	○	●	●	○
N	○	●	●	●	
S	○	○	○	○	
H					

● Hauptanwendung
Main application
Applicazione principale
○ Nebenanwendung
Secondary application
Applicazione secondaria

5

Inserts
Inserti

TNMU 31

Schneideinsätze für Seegeringnuten nach DIN 471/472 Vollprofil / Inserts for circlip grooves to DIN 471/472 full profile / Inserti per gole sedi seeger DIN 471/472 profilo completo

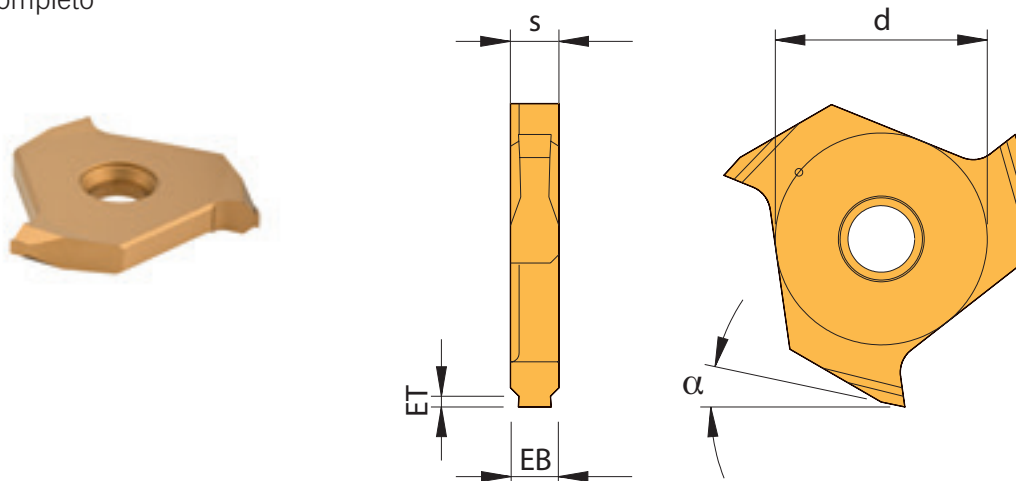

Präzisionsgeschliffene Ausführung / Precision ground execution / Esecuzione rettifica di precisione

5

						PG 15	
						beschichtet coated rivestito	unbeschichtet uncoated non rivestito
Bezeichnung Designation Articolo	EB + 0,05	ET	d	s	α	AM17C	AK10
TNMU 3111FL/R-V020	1,15	0,20	14	2,56	14°	●	●
TNMU 3111FL/R-V025	1,15	0,25	14	2,56	14°	●	●
TNMU 3111FL/R-V030	1,15	0,30	14	2,56	14°	●	●
TNMU 3111FL/R-V035	1,15	0,35	14	2,56	14°	●	●
TNMU 3111FL/R-V040	1,15	0,40	14	2,56	14°	●	●
TNMU 3113FL/R-V055	1,35	0,55	14	2,56	14°	●	●
TNMU 3116FL/R-V070	1,65	0,70	14	2,56	14°	●	●
TNMU 3116FL/R-V085	1,65	0,85	14	2,56	14°	●	●
TNMU 3116FL/R-V100	1,65	1,00	14	2,56	14°	●	●
TNMU 3118FL/R-V100	1,90	1,00	14	3,06	14°	●	●
TNMU 3118FL/R-V125	1,90	1,25	14	3,06	14°	●	●
TNMU 3121FL/R-V150	2,20	1,50	14	3,56	14°	●	●
TNMU 3126FL/R-V150	2,70	1,50	14	4,36	14°	●	●
TNMU 3126FL/R-V175	2,70	1,75	14	4,36	14°	●	●
TNMU 3131FL/R-V175	3,20	1,75	14	4,91	14°	●	●

P	●	
M	●	
K	○	●
N	○	●
S	○	○
H		

● Hauptanwendung
Main application
Applicazione principale
○ Nebenanwendung
Secondary application
Applicazione secondaria

Inserts
Inserti

TNMU 31

Schneideinsätze Vollradius / Full radius inserts / Inserti per gola a raggio completo

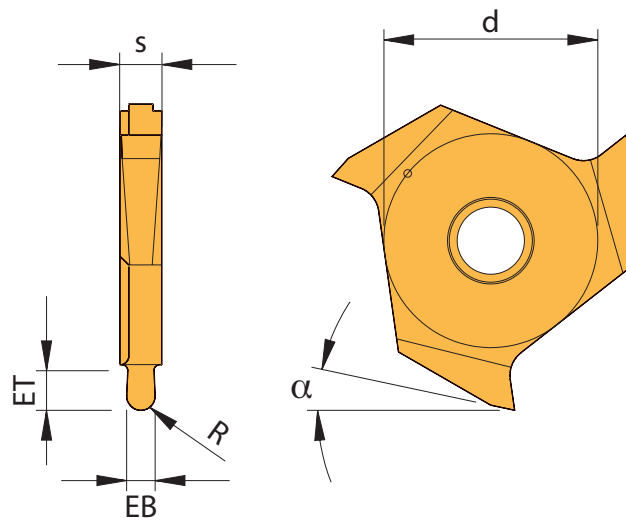
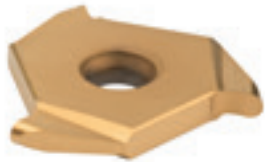

Präzisionsgeschliffene Ausführung / Precision ground execution / Esecuzione rettifica di precisione

Bezeichnung Designation Articolo	EB ± 0,02	R	ET	d	s	α	PG 15				
							beschichtet coated rivestito		unbeschichtet uncoated non rivestito		
							AM17C	PVD2	AK10	AK20	CERMET
TNMU 3120FL/R-R10	2	1,0	3	14	2,56	14°	●	●	●	●	●
TNMU 3130FL/R-R15	3	1,5	3	14	3,56	14°	●	●	●	●	●
TNMU 3140FL/R-R20	4	2,0	3	14	4,36	14°	●	●	●	●	●

P	●	○			●
M	●	○			○
K	○	○	●	●	○
N	○	●	●	●	
S	○	○	○	○	
H					

● Hauptanwendung
Main application
Applicazione principale
○ Nebenanwendung
Secondary application
Applicazione secondaria

5

TNMU 31

Schneideinsätze Axial / Inserts Axial / Inserti per gole assiale

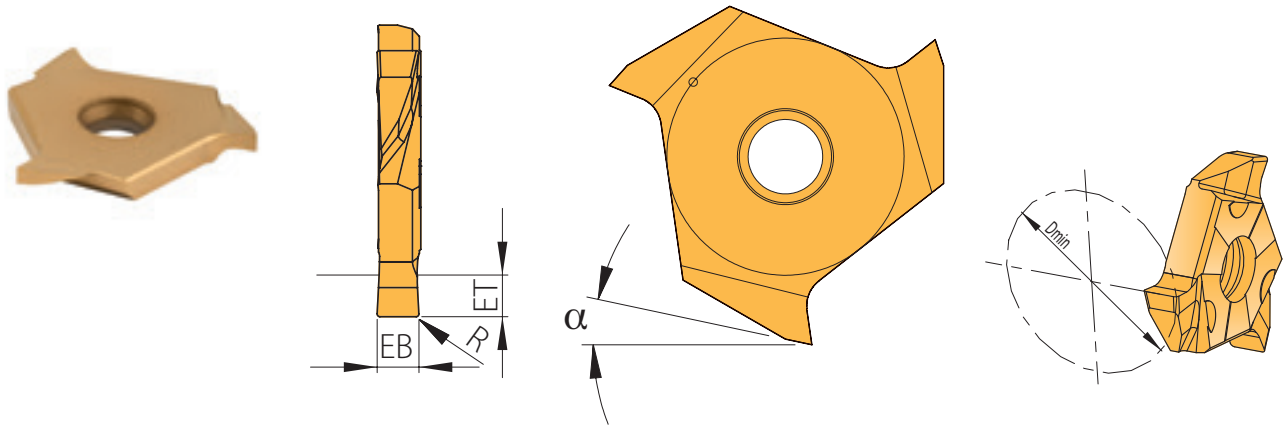

Präzisionsgeschliffene Ausführung / Precision ground execution / Esecuzione rettifica di precisione

5

Bezeichnung Designation Articolo	EB ± 0,02	R	ET	D _{min}	α	PG 15	
						beschichtet coated rivestito	unbeschichtet uncoated non rivestito
						PVD2	AK20
TNMU 3115FL/R-AX20	1,5	0,1	2	20	12°	●	●
TNMU 3120FL/R-AX20	2,0	0,2	3	20	12°	●	●
TNMU 3125FL/R-AX20	2,5	0,2	3	20	12°	●	●

P	○	
M	○	
K	○	●
N	●	●
S	○	○
H		

● Hauptanwendung
Main application
Applicazione principale

○ Nebenanwendung
Secondary application
Applicazione secondaria

TNMU 31

Schneideinsätze Geradmaße / Inserts with straight dimensions /
Inserti per canali dimensioni decimali

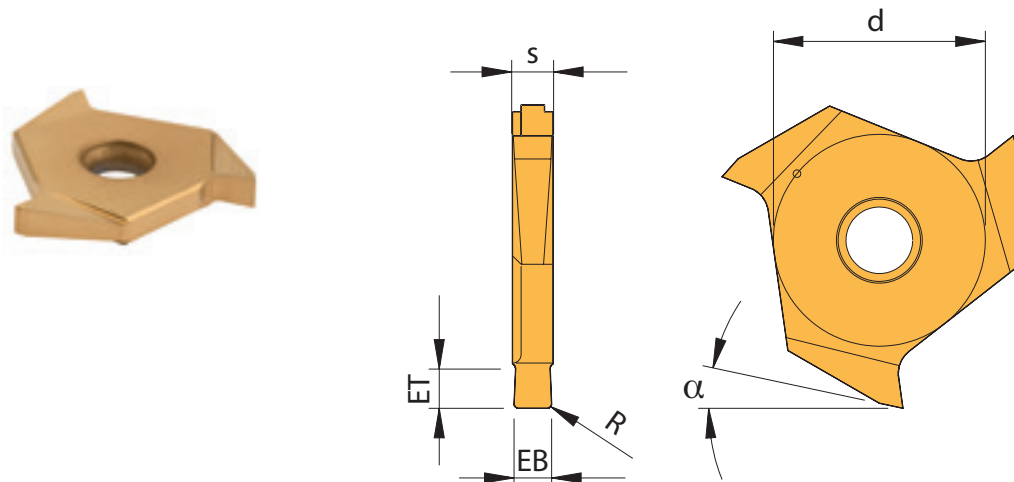

Präzisionsgeschliffene Ausführung / Precision ground execution / Esecuzione rettifica di precisione

Bezeichnung Designation Articolo	EB + 0,05	R	ET	d	s	α	PG 15						
							beschichtet coated rivestito			unbeschichtet uncoated non rivestito			
							AM17C	PVD1	PVD2	AK10	AK20	CERMET	
TNMU 3110FR	1,0	0,1	3	14	2,56	14°		●			●		
TNMU 3115FR	1,5	0,0	3	14	2,56	14°		●			●		
TNMU 3120FL/R	2,0	0,1	3	14	2,56	14°	●		●	●	●	●	
TNMU 3125FL/R	2,5	0,2	3	14	2,56	14°	●		●	●	●	●	
TNMU 3130FL/R	3,0	0,2	3	14	3,06	14°	●		●	●	●	●	
TNMU 3135FL/R	3,5	0,2	3	14	3,56	14°	●		●	●	●	●	
TNMU 3140FL/R	4,0	0,2	3	14	4,36	14°	●		●	●	●	●	
TNMU 3145FL/R	4,5	0,2	3	14	4,91	14°	●			●			
TNMU 3150FL/R	5,0	0,2	3	14	4,91	14°	●			●			

Hinweis: Für Schneideinsatz TNMU 3140F R/L, TNMU 3145F R/L und TNMU 3150F R/L den Halter STGO R/L.../4 oder STFO R/L.../4 verwenden!

Information: For inserts TNMU 3140F R/L, TNMU 3145F R/L and TNMU 3150F R/L the toolholder STGO R/L.../4 or STFO R/L.../4 must be used!

Indicazione: Per gli inserti TNMU 3140F R/L, TNMU 3145F R/L e TNMU 3150F R/L, utilizzare il portautensile STGO R/L.../4 o STFO R/L.../4!

Auf Anfrage sind verschiedene Sonderformen- und Abmessungen bis Stechbreite 7 mm lieferbar.

On request we can supply special geometries and dimensions up to grooving width 7mm. Please let us have your enquiries. Geometrie e dimensioni speciali da una larghezza di 7mm sono disponibili su richiesta. Non esitate a contattarci.

P	●	○	○			●
M	●	○	○			○
K	○	○	○	●	●	○
N	○	●	●	●	●	
S	○	○	○	○	○	
H						

● Hauptanwendung
Main application
Applicazione principale

○ Nebenanwendung
Secondary application
Applicazione secondaria



Inserts
Inserti

TNMU31

Schneideinsätze (ET = 6 und 10 mm) / Inserts (ET = 6 and 10 mm) /
Inserti (ET = 6 e 10 mm)

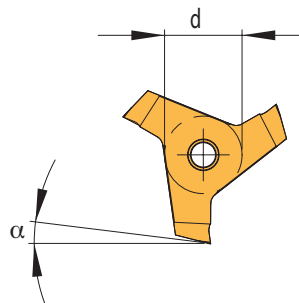
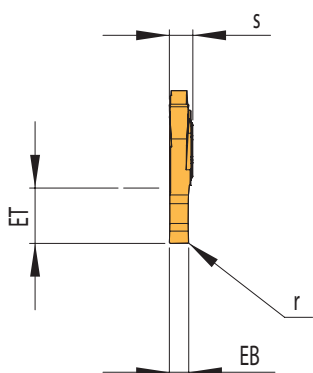

N NEU/NEW/
NUOVO

Präzisionsgeschliffene Ausführung / Precision ground execution / Esecuzione rettifica di precisione

Bezeichnung Designation Articolo	EB ± 0,02	R	ET	d	s	α	PG 15			AN1015
							beschichtet coated rivestito	beschichtet coated rivestito	unbeschichtet uncoated non rivestito	
TNMU31 1006001L/R	1,0	0,1	6	14	2,25	7°	●	●		
TNMU31 1010001L/R	1,0	0,1	10	14	2,25	7°	●	●		
TNMU31 1506001L/R	1,5	0,1	6	14	2,25	7°	●	●		
TNMU31 1510001L/R	1,5	0,1	10	14	2,25	7°	●	●		
TNMU31 2010001L/R	2,0	0,1	10	14	2,25	7°	●	●	●	
TNMU31 2010001L-ALU	2,0	0,1	10	14	2,25	7°				●
TNMU31 2010001L-S1	2,0	0,1	10	14	2,25	7°		●		
TNMU31 2010001L-T1	2,0	0,1	10	14	2,25	7°		●		
TNMU31 2510002L/R	2,5	0,2	10	14	2,75	7°	●	●		
TNMU31 3010002L/R	3,0	0,2	10	14	3,25	7°	●	●	●	
TNMU31 4010002L/R	4,0	0,2	10	14	4,25	7°	●	●	●	
TNMU31 5010004L/R	5,0	0,4	10	14	5,25	7°	●	●		

P	○	●	●	
M	●	○	○	
K				○
N		○		●
S		○		○
H				

● Hauptanwendung
Main application
Applicazione principale

○ Nebenanwendung
Secondary application
Applicazione secondaria

Spare parts and accessories
Ricambi e accessori

Artikel / Item / Articolo	PG 11
Schraube / Screw / Vite	
AS 0007	●
AS 0222	●
Schlüssel / Key / Chiave	
KS 1751	●
T5215-IP	●

Empfohlene Schnittwerte

Werkstoff- gruppe	Gliederung der Werkstoffhauptgruppen und Kennbuchstaben		Brinell-Härte	Zugfestigkeit (N/mm ²)	Zerspanungsgruppe	Schnittgeschwindigkeit V _c (m/min)		
						beschichtet		
						AM17C	PVD1	PVD2
P	Unlegierter Stahl	C ≤ 0,25 % geglüht	125	428	P1	140 - 160 - 180	100 - 115 - 130	100 - 110 - 130
		C > 0,25 ... ≤ 0,55 % geglüht	190	639	P2	110 - 135 - 160	-	-
		C > 0,25 ... ≤ 0,55 % vergütet	210	708	P3	80 - 100 - 120	60 - 80 - 100	60 - 80 - 100
		C > 0,55 % geglüht	190	639	P4	110 - 135 - 160	-	-
		C > 0,55 % vergütet	300	1013	P5	80 - 100 - 120	60 - 80 - 100	60 - 80 - 100
		Automatenstahl (kurzspanend) geglüht	220	745	P6	110 - 135 - 160	-	-
	Niedrig legierter Stahl	geglüht	175	591	P7	90 - 110 - 130	70 - 90 - 110	70 - 90 - 110
		vergütet	300	1013	P8	80 - 100 - 120	60 - 80 - 100	60 - 80 - 100
		vergütet	380	1282	P9	80 - 100 - 120	60 - 80 - 100	60 - 80 - 100
		vergütet	430	1477	P10	70 - 80 - 90	50 - 60 - 70	50 - 60 - 70
Hochlegierter Stahl und hochlegierter Werkzeugstahl	geglüht	200	675	P11	90 - 115 - 140	70 - 90 - 110	70 - 90 - 110	
	gehärtet und angelassen	300	1013	P12	70 - 80 - 90	50 - 60 - 70	50 - 60 - 70	
	gehärtet und angelassen	400	1361	P13	70 - 80 - 90	50 - 60 - 70	50 - 60 - 70	
Nichtrostender Stahl	ferritisch / martensitisch, geglüht	200	675	P14	160 - 190 - 220	130 - 165 - 200	130 - 165 - 200	
	martensitisch, vergütet	330	1114	P15	70 - 90 - 110	60 - 80 - 90	60 - 75 - 90	
M	Nichtrostender Stahl	austenitisch, abgeschreckt	200	675	M1	100 - 130 - 160	130 - 165 - 200	130 - 165 - 200
		austenitisch, ausscheidungsgehärtet (PH)	300	1013	M2	70 - 95 - 120	60 - 80 - 90	60 - 80 - 90
		austenitisch-ferritisch, Duplex	230	778	M3	50 - 65 - 80	65 - 80 - 100	65 - 80 - 100
K	Temperguss	ferritisch	200	675	K1	180 - 210 - 240	140 - 170 - 200	140 - 170 - 200
		perritisch	260	867	K2	160 - 180 - 200	120 - 140 - 160	120 - 140 - 160
	Grauguss	niedrige Festigkeit	180	602	K3	180 - 200 - 220	140 - 160 - 180	140 - 160 - 180
		hohe Festigkeit / austenitisch	245	825	K4	140 - 160 - 180	110 - 125 - 140	110 - 125 - 140
	Gusseisen mit Kugelgraphit	ferritisch	155	518	K5	160 - 180 - 200	120 - 140 - 160	120 - 140 - 160
		perritisch	265	885	K6	120 - 160 - 180	100 - 120 - 140	100 - 120 - 140
	GGV (CGI)		200	675	K7	180 - 210 - 240	140 - 170 - 200	140 - 160 - 200
N	Aluminium-Knetlegierungen	nicht aushärtbar	30	-	N1	100 - 550 - 1000	100 - 450 - 800	100 - 450 - 800
		aushärtbar, ausgehärtet	100	343	N2	100 - 450 - 800	100 - 350 - 600	100 - 350 - 600
		≤ 12 % Si, nicht aushärtbar	75	260	N3	100 - 300 - 500	100 - 250 - 400	100 - 250 - 400
	Aluminium-Gusslegierungen	≤ 12 % Si, aushärtbar, ausgehärtet	90	314	N4	100 - 300 - 500	100 - 250 - 400	100 - 250 - 400
		> 12 % Si, nicht aushärtbar	130	447	N5	100 - 400 - 500	100 - 250 - 400	100 - 250 - 400
	Magnesiumlegierungen		70	250	N6	-	-	-
	Kupfer und Kupferlegierungen (Bronze / Messing)	unlegiert, Elektrolytkupfer	100	343	N7	-	80 - 190 - 300	80 - 190 - 300
		Messing, Bronze, Rotguss	90	314	N8	-	150 - 375 - 600	150 - 375 - 600
		Cu-Legierung, kurzspanend	110	382	N9	-	80 - 190 - 300	80 - 190 - 300
		hochfest, Ampco	300	1013	N10	-	-	-
Nichtmetallische Werkstoffe	Thermoplaste (ohne abrasive Füllstoffe)	-	-	N11	80 - 290 - 500	80 - 240 - 400	80 - 240 - 400	
	Duroplaste (ohne abrasive Füllstoffe)	-	-	N12	80 - 290 - 500	80 - 240 - 400	80 - 240 - 400	
	Kunststoff glasfaserverstärkt GFRP	-	-	N13	80 - 140 - 200	80 - 120 - 160	80 - 120 - 160	
	Kunststoff kohlefaserverstärkt CFRP	-	-	N14	80 - 140 - 200	80 - 120 - 160	80 - 120 - 160	
	Kunststoff aramidfaserverstärkt AFRP	-	-	N15	80 - 140 - 200	80 - 120 - 160	80 - 120 - 160	
	Graphit (technisch)	80 Shore	-	N16	-	-	-	
S	Warmfeste Legierungen	Fe-Basis geglüht	200	675	S1	30 - 40 - 50	25 - 35 - 40	25 - 35 - 40
		ausgehärtet	280	943	S2	25 - 30 - 35	20 - 25 - 30	20 - 25 - 30
		geglüht	250	839	S3	15 - 20 - 25	10 - 15 - 20	10 - 15 - 20
		Ni- oder Co-Basis ausgehärtet	350	1177	S4	10 - 15 - 20	10 - 15 - 20	10 - 15 - 20
		gegossen	320	1076	S5	10 - 20 - 25	5 - 10 - 15	5 - 10 - 15
	Titanlegierungen	Reintitan	200	675	S6	-	-	-
		α- und β-Legierungen, ausgehärtet	375	1262	S7	-	-	-
	Wolframlegierungen	β-Legierungen	410	1396	S8	-	-	-
			300	1013	S9	-	-	-
	Molybdänlegierungen		300	1013	S10	-	-	-
H	Gehärteter Stahl	gehärtet und angelassen	50 HRC	-	H1	-	-	-
		gehärtet und angelassen	55 HRC	-	H2	-	-	-
		gehärtet und angelassen	60 HRC	-	H3	-	-	-
	Gehärtetes Gusseisen	gehärtet und angelassen	55 HRC	-	H4	-	-	-

Die Tabellenwerte sind Richtwerte.
Es kann notwendig sein, die Werte den jeweiligen Bearbeitungsumständen anzupassen.

				unbeschichtet			
	AM5140	AP5020	AP5120	AK10	AK20	CERMET	ANI015
	120 - 150 - 180	120 - 160 - 200	120 - 160 - 200	-	-	130 - 265 - 400	-
	80 - 115 - 150	80 - 115 - 150	80 - 115 - 150	-	-	120 - 235 - 350	-
	60 - 100 - 140	60 - 100 - 140	60 - 100 - 140	-	-	80 - 178 - 275	-
	80 - 115 - 150	80 - 115 - 150	80 - 115 - 150	-	-	120 - 235 - 350	-
	60 - 100 - 140	60 - 100 - 140	60 - 100 - 140	-	-	80 - 178 - 275	-
	80 - 115 - 150	80 - 115 - 150	80 - 115 - 150	-	-	120 - 235 - 350	-
	80 - 120 - 160	80 - 125 - 170	80 - 125 - 170	-	-	100 - 175 - 250	-
	60 - 95 - 130	60 - 95 - 130	60 - 95 - 130	-	-	90 - 160 - 230	-
	60 - 95 - 130	60 - 95 - 130	60 - 95 - 130	-	-	90 - 160 - 230	-
	60 - 90 - 120	60 - 90 - 120	60 - 90 - 120	-	-	60 - 105 - 150	-
	80 - 110 - 140	80 - 110 - 140	80 - 110 - 140	-	-	80 - 130 - 180	-
	50 - 85 - 120	50 - 85 - 120	50 - 85 - 120	-	-	60 - 100 - 140	-
	50 - 85 - 120	50 - 85 - 120	50 - 85 - 120	-	-	60 - 100 - 140	-
	60 - 110 - 160	60 - 115 - 170	60 - 115 - 170	-	-	80 - 150 - 220	-
	50 - 75 - 100	50 - 75 - 100	50 - 75 - 100	-	-	70 - 125 - 180	-
	60 - 110 - 160	60 - 120 - 180	60 - 120 - 180	-	-	100 - 175 - 250	-
	50 - 70 - 90	50 - 70 - 90	50 - 70 - 90	-	-	80 - 130 - 180	-
	40 - 60 - 80	40 - 65 - 90	40 - 65 - 90	-	-	50 - 90 - 125	-
	-	-	-	70 - 80 - 90	80 - 130 - 180	250 - 300 - 350	140 - 170 - 200
	-	-	-	60 - 65 - 70	70 - 110 - 150	160 - 205 - 250	120 - 140 - 160
	-	-	-	100 - 140 - 180	100 - 140 - 180	-	120 - 140 - 160
	-	-	-	90 - 105 - 120	90 - 105 - 120	-	100 - 125 - 150
	-	-	-	100 - 120 - 140	100 - 130 - 160	220 - 260 - 300	130 - 150 - 170
	-	-	-	80 - 100 - 120	70 - 95 - 120	180 - 205 - 230	90 - 110 - 130
	-	-	-	70 - 80 - 90	80 - 120 - 180	250 - 300 - 350	140 - 170 - 200
	-	100 - 300 - 500	-	650 - 825 - 1000	100 - 450 - 800	-	300 - 400 - 500
	-	100 - 200 - 300	-	300 - 500 - 700	80 - 440 - 800	-	200 - 250 - 300
	-	100 - 300 - 500	-	200 - 400 - 600	80 - 440 - 800	-	100 - 300 - 500
	-	100 - 200 - 300	-	150 - 275 - 400	-	-	100 - 200 - 300
	-	100 - 150 - 200	-	100 - 200 - 300	-	-	100 - 150 - 200
	-	-	-	-	-	-	-
	-	100 - 200 - 300	-	130 - 215 - 300	80 - 165 - 250	-	150 - 225 - 300
	-	100 - 300 - 500	-	200 - 300 - 400	150 - 325 - 500	-	200 - 350 - 500
	-	100 - 200 - 300	-	130 - 215 - 300	80 - 165 - 250	-	150 - 225 - 300
	-	-	-	-	-	-	-
	-	80 - 130 - 180	-	80 - 290 - 500	100 - 300 - 500	-	80 - 130 - 180
	-	80 - 130 - 180	-	80 - 290 - 500	100 - 300 - 500	-	80 - 130 - 180
	-	60 - 105 - 150	-	60 - 105 - 150	50 - 100 - 150	-	80 - 140 - 200
	-	60 - 105 - 150	-	60 - 105 - 150	50 - 100 - 150	-	80 - 140 - 200
	-	60 - 105 - 150	-	60 - 105 - 150	50 - 100 - 150	-	80 - 140 - 200
	-	-	-	-	-	-	-
	-	20 - 35 - 50	-	10 - 20 - 30	30 - 35 - 40	-	70 - 90 - 110
	-	20 - 30 - 40	-	15 - 23 - 30	25 - 30 - 35	-	30 - 45 - 60
	-	15 - 20 - 25	-	15 - 23 - 30	15 - 20 - 25	-	50 - 60 - 70
	-	10 - 15 - 20	-	-	10 - 15 - 20	-	50 - 65 - 80
	-	10 - 15 - 20	-	-	10 - 15 - 20	-	50 - 60 - 70
	-	50 - 85 - 120	-	15 - 33 - 50	100 - 125 - 150	-	110 - 135 - 160
	-	30 - 40 - 50	-	40 - 55 - 70	40 - 55 - 70	-	25 - 40 - 50
	-	25 - 35 - 45	-	35 - 50 - 65	35 - 50 - 65	-	20 - 35 - 45
	-	-	-	-	-	-	-
	-	-	-	-	-	-	-
	-	-	-	-	-	-	-
	-	-	-	-	-	-	-
	-	-	-	-	-	-	-
	-	-	-	-	-	-	-
	-	-	-	-	-	-	-
	-	-	-	-	-	-	-

Recommended cutting data

Material group	Structure of the material groups and identification letters		Brinell hardness HB	Tensile strength Rm (N/mm ²)	Chipping group	Cutting speed V _c (m/min)			
						coated			
						AM17C	PVD1	PVD2	
P	Unalloyed steel	C ≤ 0.25 % annealed	125	428	P1	140 - 160 - 180	100 - 115 - 130	100 - 110 - 130	
		C > 0.25 ... ≤ 0.55 % annealed	190	639	P2	110 - 135 - 160	-	-	
		C > 0.25 ... ≤ 0.55 % hardened and tempered	210	708	P3	80 - 100 - 120	60 - 80 - 100	60 - 80 - 100	
		C > 0.55 % annealed	190	639	P4	110 - 135 - 160	-	-	
		C > 0.55 % hardened and tempered	300	1013	P5	80 - 100 - 120	60 - 80 - 100	60 - 80 - 100	
		Machining steel (short-chipping) tempered	220	745	P6	110 - 135 - 160	-	-	
	Low alloyed steel	annealed	175	591	P7	90 - 110 - 130	70 - 90 - 110	70 - 90 - 110	
		hardened and tempered	300	1013	P8	80 - 100 - 120	60 - 80 - 100	60 - 80 - 100	
		hardened and tempered	380	1282	P9	80 - 100 - 120	60 - 80 - 100	60 - 80 - 100	
		hardened and tempered	430	1477	P10	70 - 80 - 90	50 - 60 - 70	50 - 60 - 70	
	High alloyed steel and high alloyed tool steel	annealed	200	675	P11	90 - 115 - 140	70 - 90 - 110	70 - 90 - 110	
		hardened	300	1013	P12	70 - 80 - 90	50 - 60 - 70	50 - 60 - 70	
		hardened	400	1361	P13	70 - 80 - 90	50 - 60 - 70	50 - 60 - 70	
	Stainless steel	ferritic / martensitic, annealed	200	675	P14	160 - 190 - 220	130 - 165 - 200	130 - 165 - 200	
		martensitic, hardened and tempered	330	1114	P15	70 - 90 - 110	60 - 80 - 90	60 - 75 - 90	
M	Stainless steel	austenitic, chilled	200	675	M1	100 - 130 - 160	130 - 165 - 200	130 - 165 - 200	
		austenitic, precipitation-hardened (PH)	300	1013	M2	70 - 95 - 120	60 - 80 - 90	60 - 80 - 90	
		austenitic-ferritic, Duplex	230	778	M3	50 - 65 - 80	65 - 80 - 100	65 - 80 - 100	
K	Malleable cast iron	ferritic	200	675	K1	180 - 210 - 240	140 - 170 - 200	140 - 170 - 200	
		pearlitic	260	867	K2	160 - 180 - 200	120 - 140 - 160	120 - 140 - 160	
	Cast iron	low tensile strength	180	602	K3	180 - 200 - 220	140 - 160 - 180	140 - 160 - 180	
		high tensile strength / austenitic	245	825	K4	140 - 160 - 180	110 - 125 - 140	110 - 125 - 140	
	Cast iron with nodular graphite	ferritic	155	518	K5	160 - 180 - 200	120 - 140 - 160	120 - 140 - 160	
		pearlitic	265	885	K6	120 - 160 - 180	100 - 120 - 140	100 - 120 - 140	
	GGV (CGI)		200	675	K7	180 - 210 - 240	140 - 170 - 200	140 - 160 - 200	
N	Aluminium alloys long chipping	not heat treatable	30	-	N1	100 - 550 - 1000	100 - 450 - 800	100 - 450 - 800	
		heat treatable, heat treated	100	343	N2	100 - 450 - 800	100 - 350 - 600	100 - 350 - 600	
	Casted aluminium alloys	≤ 12 % Si, not heat treatable	75	260	N3	100 - 300 - 500	100 - 250 - 400	100 - 250 - 400	
		≤ 12 % Si, aushärtbar, ausgehärtet	90	314	N4	100 - 300 - 500	100 - 250 - 400	100 - 250 - 400	
		> 12 % Si, not heat treatable	130	447	N5	100 - 400 - 500	100 - 250 - 400	100 - 250 - 400	
	Magnesium alloys		70	250	N6	-	-	-	
	Copper and copper alloys (Brass / Bronze)	Unalloyed, elektrolyte copper	100	343	N7	-	80 - 190 - 300	80 - 190 - 300	
		Brass, Bronze	90	314	N8	-	150 - 375 - 600	150 - 375 - 600	
		Cu-alloys, short-chipping	110	382	N9	-	80 - 190 - 300	80 - 190 - 300	
		High-tensile, Ampco	300	1013	N10	-	-	-	
Non-ferrous materials	Lead alloys (without abrasive filling material)	-	-	N11	80 - 290 - 500	80 - 240 - 400	80 - 240 - 400		
	Duroplastic (without abrasive filling material)	-	-	N12	80 - 290 - 500	80 - 240 - 400	80 - 240 - 400		
	Plastic glas fibre reinforced GFRP	-	-	N13	80 - 140 - 200	80 - 120 - 160	80 - 120 - 160		
	Plastic carbon fibre reinforced CFRP	-	-	N14	80 - 140 - 200	80 - 120 - 160	80 - 120 - 160		
	Plastic aramid fibre reinforced AFRP	-	-	N15	80 - 140 - 200	80 - 120 - 160	80 - 120 - 160		
	Graphite (tech.)		80 Shore	-	N16	-	-	-	
S	High temperature resistant alloys	Fe-Basis	annealed	200	675	S1	30 - 40 - 50	25 - 35 - 40	25 - 35 - 40
			heat treated	280	943	S2	25 - 30 - 35	20 - 25 - 30	20 - 25 - 30
		Ni- or Co-alloyed	annealed	250	839	S3	15 - 20 - 25	10 - 15 - 20	10 - 15 - 20
			heat treated	350	1177	S4	10 - 15 - 20	10 - 15 - 20	10 - 15 - 20
			casting	320	1076	S5	10 - 20 - 25	5 - 10 - 15	5 - 10 - 15
	Titanium alloys	Pure titan	200	675	S6	-	-	-	
		α- and β-alloys, heat treated	375	1262	S7	-	-	-	
	β-alloys	410	1396	S8	-	-	-		
	Wolfram alloys		300	1013	S9	-	-	-	
	Molybdän alloys		300	1013	S10	-	-	-	
H	Hardened steel	hardened	50 HRC	-	H1	-	-	-	
		hardened	55 HRC	-	H2	-	-	-	
		hardened	60 HRC	-	H3	-	-	-	
	Hardened cast iron	hardened	55 HRC	-	H4	-	-	-	

The recommended cutting data are only approximate values. It may be necessary to adjust them to each individual machining application.

				uncoated			
	AM5140	AP5020	AP5120	AK10	AK20	CERMET	ANI015
	120 - 150 - 180	120 - 160 - 200	120 - 160 - 200	-	-	130 - 265 - 400	-
	80 - 115 - 150	80 - 115 - 150	80 - 115 - 150	-	-	120 - 235 - 350	-
	60 - 100 - 140	60 - 100 - 140	60 - 100 - 140	-	-	80 - 178 - 275	-
	80 - 115 - 150	80 - 115 - 150	80 - 115 - 150	-	-	120 - 235 - 350	-
	60 - 100 - 140	60 - 100 - 140	60 - 100 - 140	-	-	80 - 178 - 275	-
	80 - 115 - 150	80 - 115 - 150	80 - 115 - 150	-	-	120 - 235 - 350	-
	80 - 120 - 160	80 - 125 - 170	80 - 125 - 170	-	-	100 - 175 - 250	-
	60 - 95 - 130	60 - 95 - 130	60 - 95 - 130	-	-	90 - 160 - 230	-
	60 - 95 - 130	60 - 95 - 130	60 - 95 - 130	-	-	90 - 160 - 230	-
	60 - 90 - 120	60 - 90 - 120	60 - 90 - 120	-	-	60 - 105 - 150	-
	80 - 110 - 140	80 - 110 - 140	80 - 110 - 140	-	-	80 - 130 - 180	-
	50 - 85 - 120	50 - 85 - 120	50 - 85 - 120	-	-	60 - 100 - 140	-
	50 - 85 - 120	50 - 85 - 120	50 - 85 - 120	-	-	60 - 100 - 140	-
	60 - 110 - 160	60 - 115 - 170	60 - 115 - 170	-	-	80 - 150 - 220	-
	50 - 75 - 100	50 - 75 - 100	50 - 75 - 100	-	-	70 - 125 - 180	-
	60 - 110 - 160	60 - 120 - 180	60 - 120 - 180	-	-	100 - 175 - 250	-
	50 - 70 - 90	50 - 70 - 90	50 - 70 - 90	-	-	80 - 130 - 180	-
	40 - 60 - 80	40 - 65 - 90	40 - 65 - 90	-	-	50 - 90 - 125	-
	-	-	-	70 - 80 - 90	80 - 130 - 180	250 - 300 - 350	140 - 170 - 200
	-	-	-	60 - 65 - 70	70 - 110 - 150	160 - 205 - 250	120 - 140 - 160
	-	-	-	100 - 140 - 180	100 - 140 - 180	-	120 - 140 - 160
	-	-	-	90 - 105 - 120	90 - 105 - 120	-	100 - 125 - 150
	-	-	-	100 - 120 - 140	100 - 130 - 160	220 - 260 - 300	130 - 150 - 170
	-	-	-	80 - 100 - 120	70 - 95 - 120	180 - 205 - 230	90 - 110 - 130
	-	-	-	70 - 80 - 90	80 - 120 - 180	250 - 300 - 350	140 - 170 - 200
	-	100 - 300 - 500	-	650 - 825 - 1000	100 - 450 - 800	-	300 - 400 - 500
	-	100 - 200 - 300	-	300 - 500 - 700	80 - 440 - 800	-	200 - 250 - 300
	-	100 - 300 - 500	-	200 - 400 - 600	80 - 440 - 800	-	100 - 300 - 500
	-	100 - 200 - 300	-	150 - 275 - 400	-	-	100 - 200 - 300
	-	100 - 150 - 200	-	100 - 200 - 300	-	-	100 - 150 - 200
	-	-	-	-	-	-	-
	-	100 - 200 - 300	-	130 - 215 - 300	80 - 165 - 250	-	150 - 225 - 300
	-	100 - 300 - 500	-	200 - 300 - 400	150 - 325 - 500	-	200 - 350 - 500
	-	100 - 200 - 300	-	130 - 215 - 300	80 - 165 - 250	-	150 - 225 - 300
	-	-	-	-	-	-	-
	-	80 - 130 - 180	-	80 - 290 - 500	100 - 300 - 500	-	80 - 130 - 180
	-	80 - 130 - 180	-	80 - 290 - 500	100 - 300 - 500	-	80 - 130 - 180
	-	60 - 105 - 150	-	60 - 105 - 150	50 - 100 - 150	-	80 - 140 - 200
	-	60 - 105 - 150	-	60 - 105 - 150	50 - 100 - 150	-	80 - 140 - 200
	-	60 - 105 - 150	-	60 - 105 - 150	50 - 100 - 150	-	80 - 140 - 200
	-	-	-	-	-	-	-
	-	20 - 35 - 50	-	10 - 20 - 30	30 - 35 - 40	-	70 - 90 - 110
	-	20 - 30 - 40	-	15 - 23 - 30	25 - 30 - 35	-	30 - 45 - 60
	-	15 - 20 - 25	-	15 - 23 - 30	15 - 20 - 25	-	50 - 60 - 70
	-	10 - 15 - 20	-	-	10 - 15 - 20	-	50 - 65 - 80
	-	10 - 15 - 20	-	-	10 - 15 - 20	-	50 - 60 - 70
	-	50 - 85 - 120	-	15 - 33 - 50	100 - 125 - 150	-	110 - 135 - 160
	-	30 - 40 - 50	-	40 - 55 - 70	40 - 55 - 70	-	25 - 40 - 50
	-	25 - 35 - 45	-	35 - 50 - 65	35 - 50 - 65	-	20 - 35 - 45
	-	-	-	-	-	-	-
	-	-	-	-	-	-	-
	-	-	-	-	-	-	-
	-	-	-	-	-	-	-
	-	-	-	-	-	-	-
	-	-	-	-	-	-	-
	-	-	-	-	-	-	-
	-	-	-	-	-	-	-
	-	-	-	-	-	-	-

Parametri di taglio suggeriti

Gruppo materiale	Struttura dei gruppi di materiali e lettere di riferimento		Durezza Brinell	Resistenza Rm (N/mm ²)	Gruppo di lavoro	Velocità di taglio V _c (m/min)		
						rivestito		
						AM17C	PVD1	PVD2
P	Acciai non legato	C ≤ 0,25 % ricotto	125	428	P1	140 - 160 - 180	100 - 115 - 130	100 - 110 - 130
		C > 0,25 ... ≤ 0,55 % ricotto	190	639	P2	110 - 135 - 160	-	-
		C > 0,25 ... ≤ 0,55 % bonificato	210	708	P3	80 - 100 - 120	60 - 80 - 100	60 - 80 - 100
		C > 0,55 % ricotto	190	639	P4	110 - 135 - 160	-	-
		C > 0,55 % bonificato	300	1013	P5	80 - 100 - 120	60 - 80 - 100	60 - 80 - 100
	Acciai debolmente legati	Acciaio (truciolo corto) ricotto	220	745	P6	110 - 135 - 160	-	-
		ricotto	175	591	P7	90 - 110 - 130	70 - 90 - 110	70 - 90 - 110
		bonificato	300	1013	P8	80 - 100 - 120	60 - 80 - 100	60 - 80 - 100
		bonificato	380	1282	P9	80 - 100 - 120	60 - 80 - 100	60 - 80 - 100
	Acciai fortemente legati e acciai da utensili	bonificato	430	1477	P10	70 - 80 - 90	50 - 60 - 70	50 - 60 - 70
ricotto		200	675	P11	90 - 115 - 140	70 - 90 - 110	70 - 90 - 110	
temprato e rinvenuto		300	1013	P12	70 - 80 - 90	50 - 60 - 70	50 - 60 - 70	
Acciai inossidabili	temprato e rinvenuto	400	1361	P13	70 - 80 - 90	50 - 60 - 70	50 - 60 - 70	
	ferritico / martensitico, ricotto	200	675	P14	160 - 190 - 220	130 - 165 - 200	130 - 165 - 200	
M	Acciai inossidabili	martensitico, bonificato	330	1114	P15	70 - 90 - 110	60 - 80 - 90	60 - 75 - 90
		austenitico, trattato o temperato	200	675	M1	100 - 130 - 160	130 - 165 - 200	130 - 165 - 200
		austenitico, indurimento per precipitazione (PH)	300	1013	M2	70 - 95 - 120	60 - 80 - 90	60 - 80 - 90
K	Ghisa temprata	austenitico-ferritico, Duplex	230	778	M3	50 - 65 - 80	65 - 80 - 100	65 - 80 - 100
		ferritico	200	675	K1	180 - 210 - 240	140 - 170 - 200	140 - 170 - 200
	Ghisa grigia	perlitica	260	867	K2	160 - 180 - 200	120 - 140 - 160	120 - 140 - 160
		bassa resistenza	180	602	K3	180 - 200 - 220	140 - 160 - 180	140 - 160 - 180
	Ghisa sferoidale	alta resistenza / austenitico	245	825	K4	140 - 160 - 180	110 - 125 - 140	110 - 125 - 140
		ferritico	155	518	K5	160 - 180 - 200	120 - 140 - 160	120 - 140 - 160
GGV (CGI)	perlitica	265	885	K6	120 - 160 - 180	100 - 120 - 140	100 - 120 - 140	
N	Leghe di Alluminio stampato	200	675	K7	180 - 210 - 240	140 - 170 - 200	140 - 160 - 200	
		non invecchiato	30	-	N1	100 - 550 - 1000	100 - 450 - 800	100 - 450 - 800
	Leghe di Alluminio da fusione	rinvenuto, invecchiato	100	343	N2	100 - 450 - 800	100 - 350 - 600	100 - 350 - 600
		≤ 12 % Si, non invecchiato	75	260	N3	100 - 300 - 500	100 - 250 - 400	100 - 250 - 400
		≤ 12 % Si, rinvenuto, invecchiato	90	314	N4	100 - 300 - 500	100 - 250 - 400	100 - 250 - 400
	Leghe di magnesio	> 12 % Si, non invecchiato	130	447	N5	100 - 400 - 500	100 - 250 - 400	100 - 250 - 400
		70	250	N6	-	-	-	
	Rame e Leghe di Rame (Bronzo / Ottone)	Non legati, Rame Elettrolitico	100	343	N7	-	80 - 190 - 300	80 - 190 - 300
		Ottone, Bronzo	90	314	N8	-	150 - 375 - 600	150 - 375 - 600
		Leghe Cu, truciolo corto	110	382	N9	-	80 - 190 - 300	80 - 190 - 300
Alta resistenza, Ampco		300	1013	N10	-	-	-	
Materiali non metallici	Leghe al piombo (senza materiale di riempimento abrasivo)	-	-	N11	80 - 290 - 500	80 - 240 - 400	80 - 240 - 400	
	Duroplastico (senza materiale di riempimento abrasivo)	-	-	N12	80 - 290 - 500	80 - 240 - 400	80 - 240 - 400	
	Plastica rinforzata in fibra di vetro GFRP	-	-	N13	80 - 140 - 200	80 - 120 - 160	80 - 120 - 160	
	Plastica rinforzata in fibra di carbonio CFRP	-	-	N14	80 - 140 - 200	80 - 120 - 160	80 - 120 - 160	
	Plastica rinforzata in fibra aramidica AFRP	-	-	N15	80 - 140 - 200	80 - 120 - 160	80 - 120 - 160	
	Grafite (tecnico)	80 Shore	-	N16	-	-	-	
S	Leghe resistenti al calore	Base-Fe ricotto	200	675	S1	30 - 40 - 50	25 - 35 - 40	25 - 35 - 40
		invecchiato	280	943	S2	25 - 30 - 35	20 - 25 - 30	20 - 25 - 30
		Base Ni o Co ricotto	250	839	S3	15 - 20 - 25	10 - 15 - 20	10 - 15 - 20
		invecchiato	350	1177	S4	10 - 15 - 20	10 - 15 - 20	10 - 15 - 20
		da fusione	320	1076	S5	10 - 20 - 25	5 - 10 - 15	5 - 10 - 15
	Leghe di Titanio	Titanio puro	200	675	S6	-	-	-
		Leghe α e β, invecchiato	375	1262	S7	-	-	-
	Leghe di tungsteno	Leghe β	410	1396	S8	-	-	-
		300	1013	S9	-	-	-	
	Leghe di molibdeno	300	1013	S10	-	-	-	
H	Acciaio Temprato	temprato e rinvenuto	50 HRC	-	H1	-	-	-
		temprato e rinvenuto	55 HRC	-	H2	-	-	-
		temprato e rinvenuto	60 HRC	-	H3	-	-	-
	Ghisa Temprata	temprato e rinvenuto	55 HRC	-	H4	-	-	-

I dati indicati in tabella sono valori approssimati.
Può essere necessario adattarli alle singole applicazioni di lavorazione.

Einstecken / Grooving / Scanalatura

	Schneideinsatz / Insert / Insetto	
	TN MU 17	TN MU 31
f_v	0,2 – 0,12	0,02 – 0,15
f_n	0,02 – 0,12	0,02 – 0,15
f_k	①	①

Hinweis: Bei rechten und linken Schneidplatten Vorschub um 30 – 50% reduzieren.

Remark: When using right or left-hand inserts, reduce feed by 30 – 50%.

Nota: Per gli inserti a destra e a sinistra, ridurre l'avanzamento dal 30 al 50%.

① Kopieren nicht möglich!
Copying not possible!
Copiatura non possibile!

Clip-Groove® axial / Clip-Groove® axial / Clip-Groove® assiale

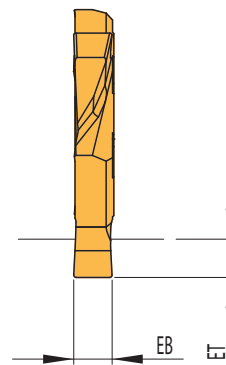
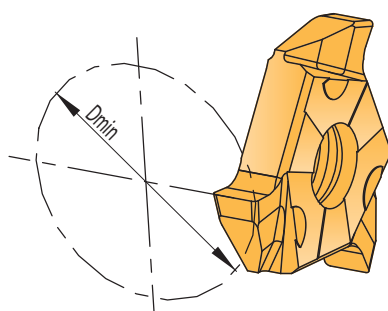
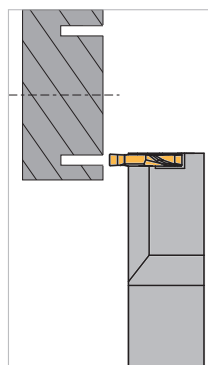

Clip-Groove® axial – speziell für Formeinstiche bei der Axialbearbeitung.

Clip-Groove® axial especially for face grooving.

Clip-Groove® assiale – specifico per lavorazioni a tuffo assiali.

TN MU 31 – Drehen der Schulter / TN MU 31 – Turning up to a shoulder / TN MU 31 - Lavorazione della superficie frontale

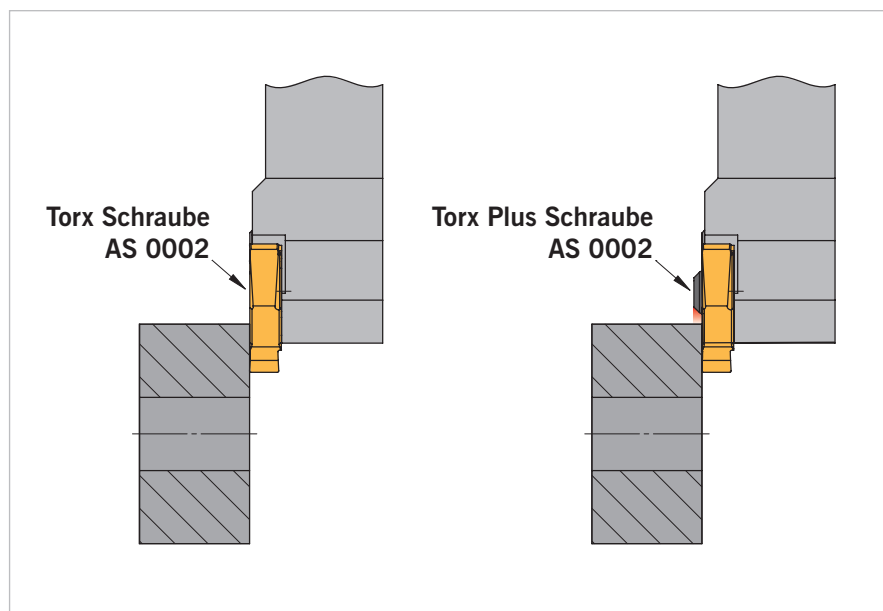

AS 0002 – Schraube / Screw / Vite

+ Drehen der Schulter problemlos möglich

- TORX-Profil verschleißanfälliger

+ Turning up to a shoulder is no problem, but

- TORX screw profile is weaker

+ Una lavorazione della superficie frontale è possibile senza problemi

- Svantaggio è solo la usura della vite AS 0002 della versione TORX

AS 0222 – Schraube / Screw / Vite

+ TORX-Profil tiefer und verschleißfester

- Drehen der Schulter, aufgrund des Schraubenüberstandes

+ The TORX profile is larger and stronger but therefore not suitable for turning up to shoulder

+ Il profilo della vite Torx-Plus è più resistente contro la usura della testa della vite
- Una lavorazione della superficie frontale in questo caso non è possibile perché la testa della vite non è affondata nel inserto

Bei der Bearbeitung mit einem TN MU 31 Schneideinsatz ist ein Drehen der Schulter nur in Verbindung mit der Montage des Schneideinsatzes durch einen AS 0002 Schraube möglich. Beim Einsatz einer AS 0222 Schraube besteht Kollisionsgefahr.

When machining with a TN MU 31 insert it is necessary to replace screw with an AS0002 screw. Using AS0222 could cause collision.

Una lavorazione della superficie frontale è solo possibile in combinazione con il utilizzo della vite AS 0002. Nella lavorazione superficie frontale con il utilizzo della vite AS 0222 è possibile di avere collisione con il pezzo.



PROFIL-CUT

PROFIL-CUT

PROFIL-CUT

Formeinstechsystem

Form grooving system

Sistema per inserti a profilo

• Systemvorstellung	• Introduction	• Caratteristiche del sistema	338 – 339
• Werkzeugauswahl	• Tool shank options	• Tipologie di corpo utensile	340
• Bezeichnungssystem	• Designation system	• Sistema di identificazione	341
• Monoblockhalter	• Monoblock holders	• Utensili monoblocco	342 – 343
• Sortenbeschreibung	• Grade description	• Descrizione delle Qualità	344
• Schneideinsätze	• Inserts	• Inserti	345
• Ersatzteile und Zubehör	• Spare parts and accessories	• Ricambi e accessori	346
• Schnittwerte	• Cutting data	• Parametri di taglio	348 – 350

Formstechsystem zur Eigenprofilierung der Schneidplatte

Grooving system for one plunge groove cutting

Sistema per inserti a profilo



Immense Einsparpotentiale mit dem Einsatz des PROFIL-CUT (Profil- und Formwerkzeugsystem) in Ihrer Fertigung durch Einsparung von Werkzeugkosten und Reduzierung der Bearbeitungszeiten. Gerne fertigen wir Ihnen spezielle Profil-Formplatten nach Ihren Vorgaben an, die wir schnell und präzise inhouse schleifen.

Alternativ stehen Ihnen Halbzeuge zur Verfügung, die Sie eigenständig nacharbeiten können.

By utilizing the PROFIL-CUT you could benefit from vast cost savings in tooling costs and machine time. We are ready to produce your specific profile form inserts; we grind them in-house, accurately and quickly.

Alternatively we can supply our blanks which you can grind yourselves.

Il sistema PROFIL-CUT permette notevoli risparmi nella produzione di particolari con sagome complesse. La profilatura degli inserti permette di lavorare a tuffo l'intera sagoma richiesta riducendo i tempi di lavorazione. Gli inserti possono poi essere rivestiti per aumentare la durata e la tenuta del tagliente.

E' anche possibile acquistare i grezzi per una personalizzazione del profilo.

Beispiele / Examples / Esempio

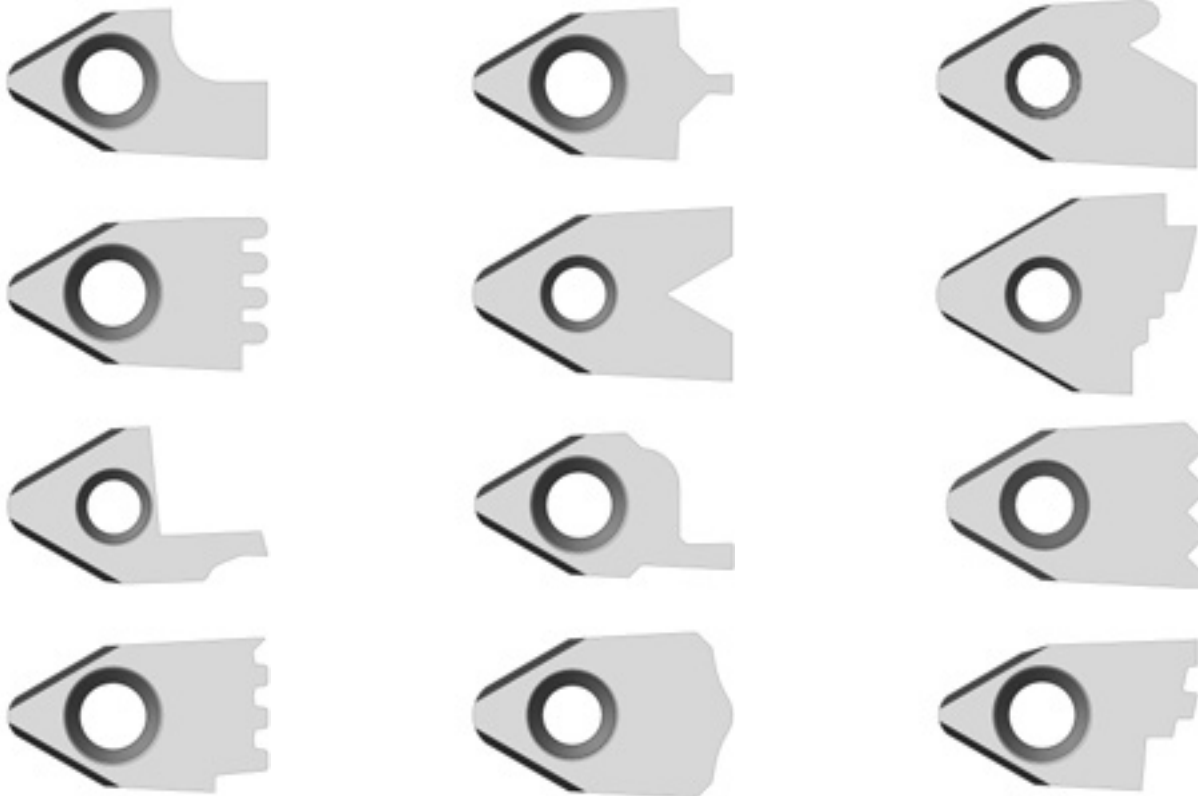

6

Fakten

- Verschiedene Rohlinge für unterschiedliche Profilgrößen
- Einfachste Montage für leichtes Handling und geringste Rüstzeiten. Sicherer Plattensitz für absolute Prozesssicherheit
- Sonderprofile bis Stechbreite 25 mm möglich
- Sonderformen nach Kundenzeichnung auf Anfrage

Introduction

- Different blanks for special profile grooves
- Easiest assembly for simple handling and quick insert changes
- Secure insert seat for absolute process reliability
- Special profiles up to a width of 25 mm possible
- Customer specific shapes on request

Descrizione

- Diverse misure di semilavorato
- Montaggio semplice per un facile utilizzo risparmio di tempo
- Sede inserto sicura
- Profili speciali possibili fino a 25 mm
- Forme speciali a disegno su richiesta

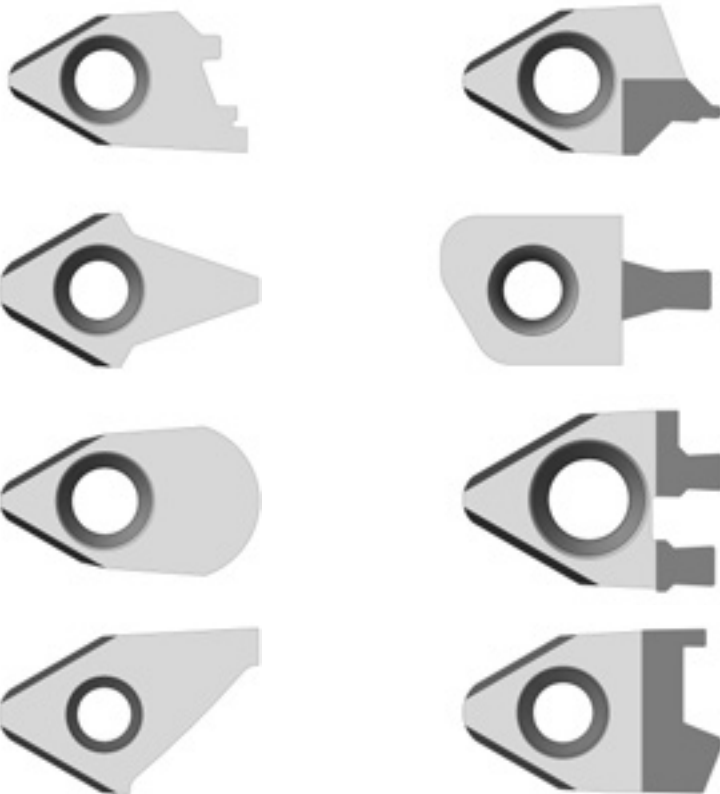

Auf Anfrage liefern wir Ihnen auch PKD- oder CBN-bestückte Schneideinsätze.

On request we also supply PKD or CBN tipped inserts.

A richiesta è inoltre possibile realizzare profili su riporti in CBN o PKD.



Monoblockhalter / *Monoblock holders* / Utensili monoblocco

Seite/Page/Pagina **342 – 343**

6

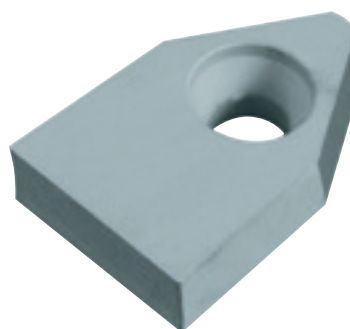

Schneideinsätze / *Inserts* / Inserti

Seite/Page/Pagina **345**

Designation system
Sistema di identificazione

Monoblockhalter / Monoblock holders / Utensili monoblocco

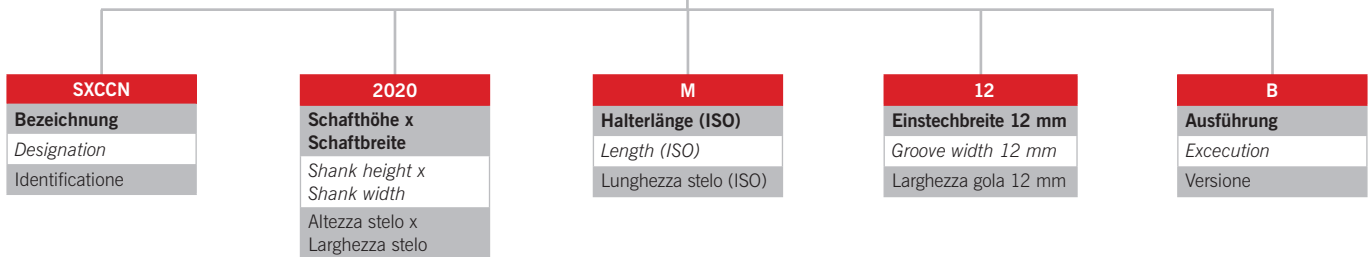

Schneideinsätze / Inserts / Inserti

6

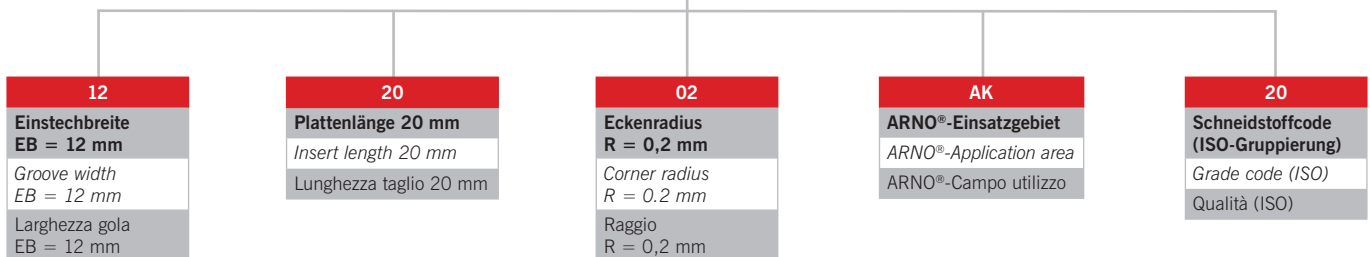
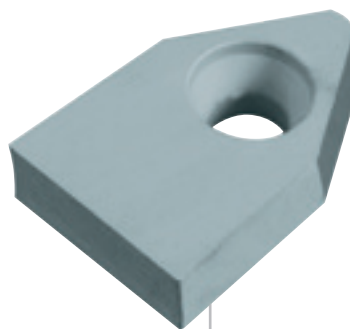

Formeinstechen / Form groove system / Sistema di gole e forma

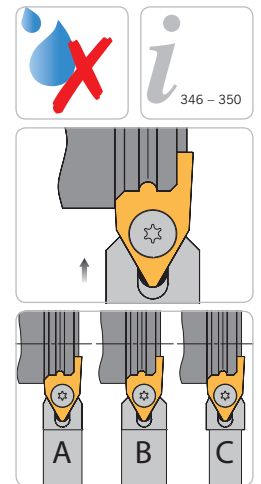
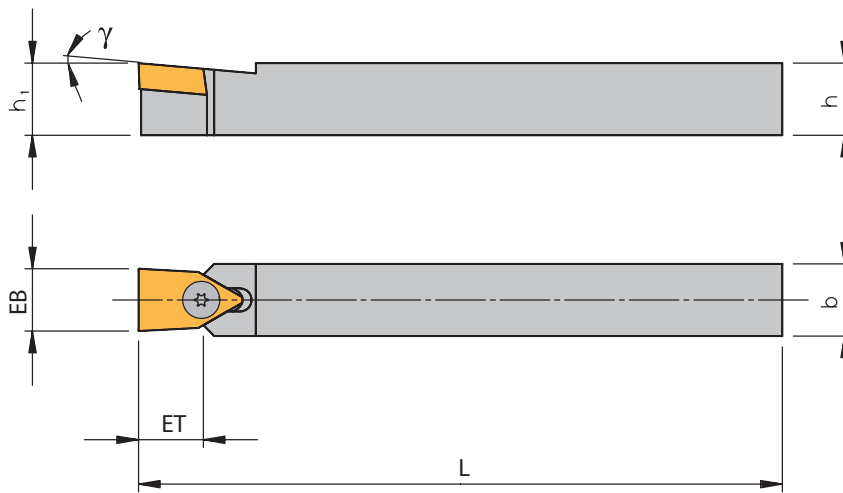

Trägerwerkzeuge / Holders / Utensili

Bezeichnung Designation Articolo	EB	ET	h	h_1	b	L	γ	PG 12	Schneideinsatz Insert Inserto
SXCCN 1212 K12-A	12	-	12	12	12	125	5°	●	122002...
SXCCN 1414 K12-B	12	12,5	14	14	14	125	5°	●	122002...
SXCCN 1414 K16-C	16	22,0	14	14	14	125	5°	●	162502...
SXCCN 1612 K12-A	12	-	16	16	12	125	5°	●	122002...
SXCCN 1616 K12-B	12	12,5	16	16	16	125	5°	●	122002...
SXCCN 1616 K16-A	16	-	16	16	16	125	5°	●	162502...
SXCCN 1616 K21-C	21	30,0	16	16	16	125	5°	●	213202...
SXCCN 2020 M12-B	12	12,6	20	20	20	150	5°	●	162502...
SXCCN 2020 M16-B	16	14,5	20	20	20	150	5°	●	162502...
SXCCN 2020 M21-A	21	-	20	20	20	150	5°	●	213202...
SXCCN 2025 M25-A	25	14,0	20	20	25	150	8°	●	253202...
SXCCN 2525 M12-B	12	12,6	25	25	25	150	5°	●	122002...
SXCCN 2525 M16-B	16	14,5	25	25	25	150	5°	●	162502...
SXCCN 2525 M21-B	21	18,2	25	25	25	150	5°	●	213202...
SXCCN 2525 M25-A	25	14,0	25	25	25	150	8°	●	253202...

Ersatzteile / Spare Parts / Ricambi

Trägerwerkzeug Holder Utensile	Schraube Screw Vite	Schlüssel Key Chiave
SXCCN .. 12..	SS 1221	KS 1111
SXCCN .. 14 .. / SXCCN .. 16 ..	SS 9950	KS 2520
SXCCN .. 21..	SS 9980	KS 2525
SXCCN .. 25..	SS 9980	KS 2525

6

Formeinstechen / Form groove system / Sistema di gole e forma

Klemhalter zur Eigenprofilierung der Schneidplatte / Holder only for grinding special profiles / Stelo per affilatura profili speciali

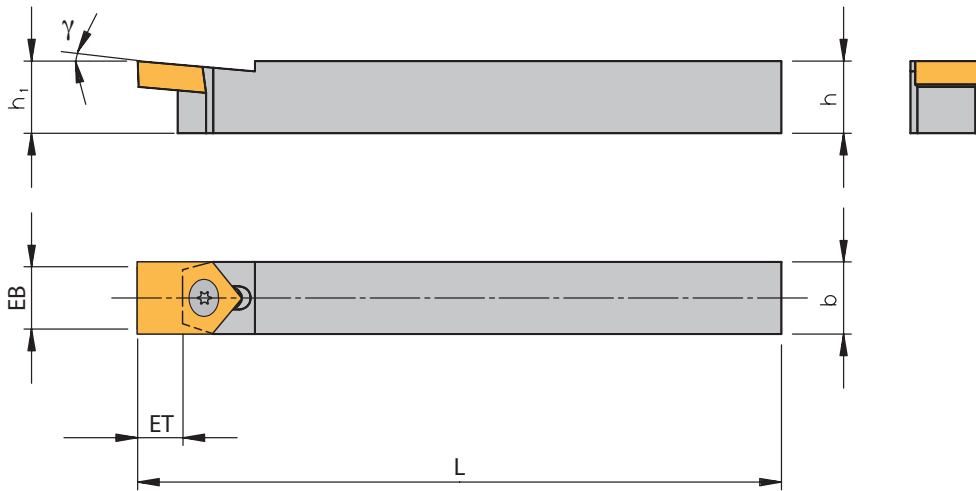
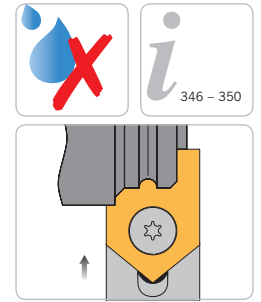

Trägerwerkzeuge / Holders / Utensili

Bezeichnung Designation Articolo	EB	ET	h	h ₁	b	L	γ	PG 12	Schneideinsatz Insert Inserto
GXCCN 1212 K12	12	5,0	12	12	12	125	5°	●	122002...
GXCCN 1616 K16	16	6,5	16	16	16	125	5°	●	162502...
GXCCN 2020 M21	21	9,5	20	20	20	150	5°	●	213202...
GXCCN 2025 M25	25	9,5	20	25	25	150	8°	●	253202...

Ersatzteile / Spare Parts / Ricambi

Trägerwerkzeug Holder Utensile	Schraube Screw Vite	Schlüssel Key Chiave
GXCCN 1212 K12	SS 1221	KS 1111
GXCCN 1616 K16	SS 9950	KS 2520
GXCCN 2020 M21	SS 9980	KS 2525
GXCCN 2025 M25	SS 9980	KS 2525

Unbeschichtet / Uncoated / Non rivestito

AK20

Hartmetallsorte mit höherer Zähigkeit zur Bearbeitung von Al und Al-Legierungen, Kupfer, Bronze, NE-Metalle und hochschmelzenden Werkstoffen bei mittleren Spannerschnitten unter ungünstigen Bearbeitungsbedingungen, wie unterbrochene Schnitte.

A grade with great resilience for machining Al and Al-alloys, copper, brass, non-ferrous and refractory metals with medium chip cross sections under unfavourable machining conditions and interrupted cuts.

Un grado con grande resilienza per la lavorazione dell'Alluminio e sue leghe, ottone, rame, metalli non ferrosi e refrattari (p. e. niobio, tantalio, molibdeno, tungsteno) con sezioni di truciolo in condizioni di taglio non favorevoli e taglio interrotto.

AP40

Bearbeitung von Stahl, Stahlguss und austenitischen Stählen mit mittleren bis niedrigen Schnittgeschwindigkeiten, mittleren bis großen Spannerschnitten, auch unter ungünstigen Bedingungen.

Machining of steel, cast steel and austenitic steel, at medium to lower cutting speeds, medium to large chip-cross-sections, also under unfavourable conditions.

Lavorazione d'acciaio, fusioni, acciai austenitici a velocità di taglio medie e basse, sezioni di taglio medie e grandi, anche in condizioni difficili.

CERMET

Bearbeitung von Stahl, Stählen mittlerer Festigkeit sowie rostfreiem Stahl und Guss-eisen mit Kugelgraphit. Bedingt einsetzbar für Grauguss.

Machining of steel, steels with medium tensile strength as well as stainless steel and spheroidal cast iron. Limited use on grey cast iron.

Lavorazione dell'acciaio, acciai di durezza media come l'acciaio inossidabile e la ghisa sferoidale. Uso limitato sulla ghisa grigia.

Formeinstechen / Form groove system / Sistema di gole e forma

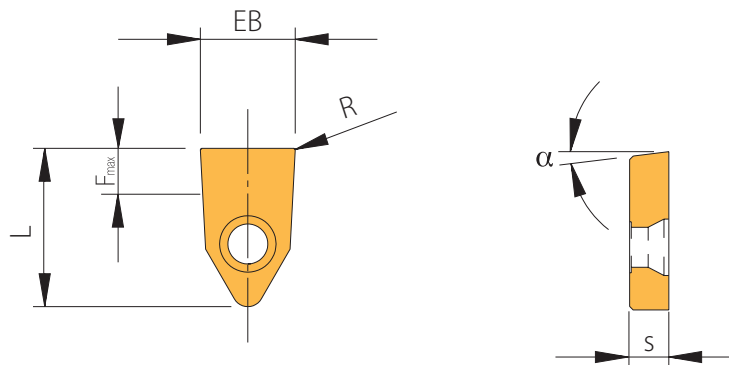

Geschliffene Ausführung / Ground execution / Esecuzione rettificato

							PG 15		
							unbeschichtet uncoated non rivestito		
Bezeichnung Designation Articolo	EB	s	R	L	F _{max}	α	AK20	AP40	CERMET
122002	12	5,0	0,2	20	7,5	7°	●	●	●
162502	16	6,5	0,2	25	10,0	7°	●	●	●
213202	21	7,5	0,2	32	12,0	7°	●	●	●
253202	25	5,0	0,2	32	12,0	7°	●	●	●

Hinweis: Sonderformen nach Kundenzeichnung auf Anfrage!
Information: Special form inserts to customer's drawing on request!
Indicazione: Esecuzione di profili speciali su richiesta!

P		●	●
M			○
K	●		○
N	●		
S	○		
H			

● Hauptanwendung
Main application
Applicazione principale
○ Nebenanwendung
Secondary application
Applicazione secondaria



Spare parts and accessories
Ricambi e accessori

Artikel / Item / Articolo	PG 11
Schraube / Screw / Vite	
SS 1221	●
SS 9950	●
SS 9980	●
Schlüssel / Key / Chiave	
KS 1111	●
KS 2520	●
KS 2525	●

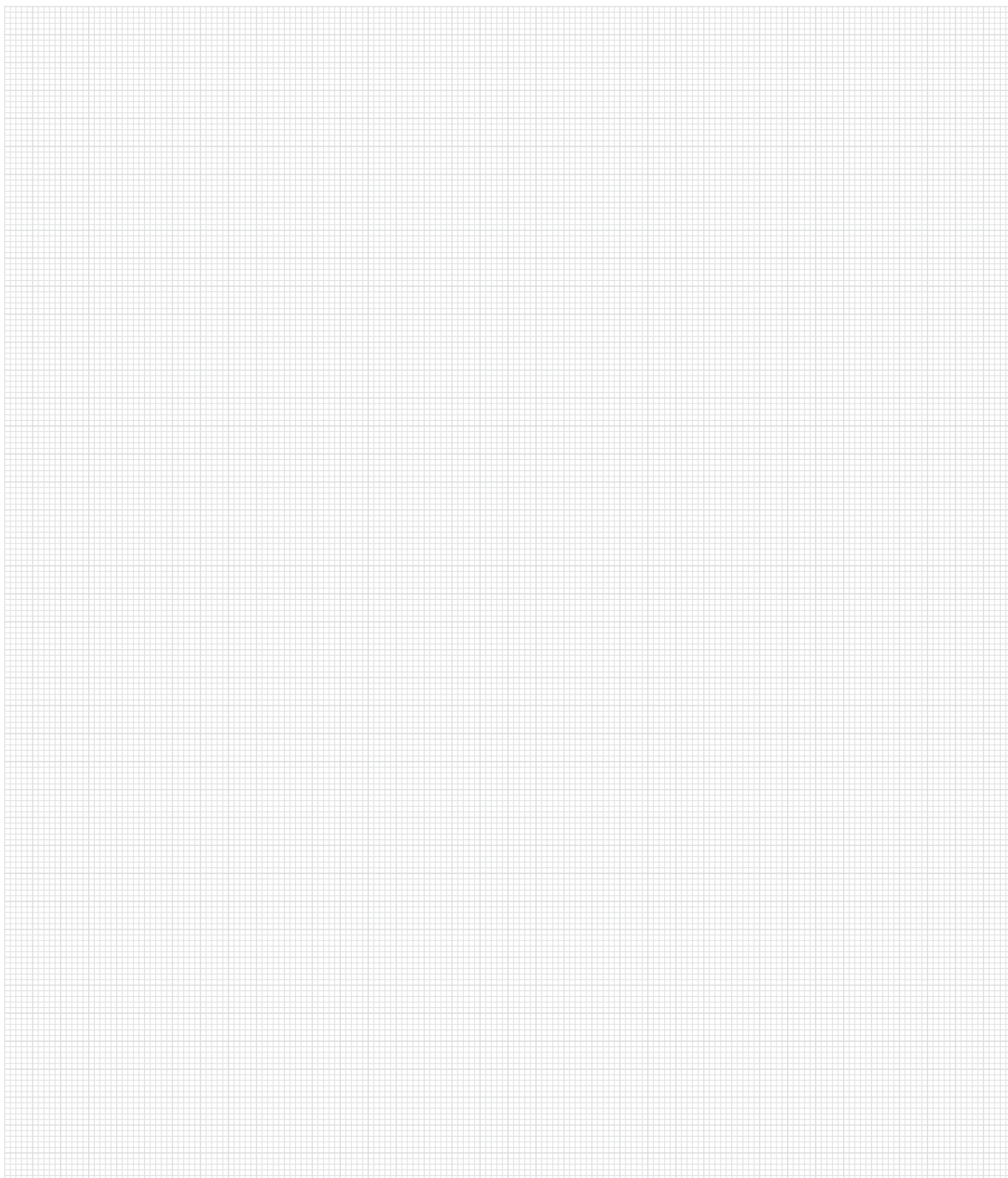

Weitere Informationen finden Sie unter:

For more information see:

Per maggiori informazioni visita il sito:

www.arno.de

Werkstoff- gruppe	Gliederung der Werkstoffhauptgruppen und Kennbuchstaben		Brinell-Härte	Zugfestigkeit (N/mm ²)	Zerspanungsgruppe	Schnittgeschwindigkeit V _c (m/min)		
						unbeschichtet		
						AK20	AP40	CERMET
P	Unlegierter Stahl	C ≤ 0,25 % geglüht	125	428	P1			
		C > 0,25 ... ≤ 0,55 % geglüht	190	639	P2			
		C > 0,25 ... ≤ 0,55 % vergütet	210	708	P3			
		C > 0,55 % geglüht	190	639	P4			
		C > 0,55 % vergütet	300	1013	P5			
		Automatenstahl (kurzspanend) geglüht	220	745	P6			
	Niedrig legierter Stahl	geglüht	175	591	P7			
		vergütet	300	1013	P8			
		vergütet	380	1282	P9			
		vergütet	430	1477	P10			
	Hochlegierter Stahl und hochlegierter Werkzeugstahl	geglüht	200	675	P11			
		gehärtet und angelassen	300	1013	P12			
		gehärtet und angelassen	400	1361	P13			
	Nichtrostender Stahl	ferritisch / martensitisch, geglüht	200	675	P14			
		martensitisch, vergütet	330	1114	P15			
M	Nichtrostender Stahl	austenitisch, abgeschreckt	200	675	M1			
		austenitisch, ausscheidungsgehärtet (PH)	300	1013	M2			
		austenitisch-ferritisch, Duplex	230	778	M3			
K	Temperguss	ferritisch	200	675	K1			
		perritisch	260	867	K2			
	Grauguss	niedrige Festigkeit	180	602	K3			
		hohe Festigkeit / austenitisch	245	825	K4			
	Gusseisen mit Kugelgraphit	ferritisch	155	518	K5			
		perritisch	265	885	K6			
	GGV (CGI)		200	675	K7			
N	Aluminium-Knetlegierungen	nicht aushärtbar	30	-	N1	Schnittwerte abhängig von der Profilierung der Schneidplatte		
		aushärtbar, ausgehärtet	100	343	N2			
	Aluminium-Gusslegierungen	≤ 12 % Si, nicht aushärtbar	75	260	N3			
		≤ 12 % Si, aushärtbar, ausgehärtet	90	314	N4			
		> 12 % Si, nicht aushärtbar	130	447	N5			
	Magnesiumlegierungen		70	250	N6			
	Kupfer und Kupferlegierungen (Bronze / Messing)	unlegiert, Elektrolytkupfer	100	343	N7			
		Messing, Bronze, Rotguss	90	314	N8			
		Cu-Legierung, kurzspanend	110	382	N9			
		hochfest, Ampco	300	1013	N10			
	Nichtmetallische Werkstoffe	Thermoplaste (ohne abrasive Füllstoffe)	-	-	N11			
		Duroplaste (ohne abrasive Füllstoffe)	-	-	N12			
		Kunststoff glasfaserverstärkt GFRP	-	-	N13			
		Kunststoff kohlefaserverstärkt CFRP	-	-	N14			
		Kunststoff aramidfaserverstärkt AFRP	-	-	N15			
		Graphit (technisch)	80 Shore	-	N16			
S	Warmfeste Legierungen	Fe-Basis geglüht	200	675	S1			
		ausgehärtet	280	943	S2			
		geglüht	250	839	S3			
		Ni- oder Co-Basis ausgehärtet	350	1177	S4			
		gegossen	320	1076	S5			
	Titanlegierungen	Reintitan	200	675	S6			
		α- und β-Legierungen, ausgehärtet	375	1262	S7			
		β-Legierungen	410	1396	S8			
	Wolframlegierungen		300	1013	S9			
	Molybdänlegierungen		300	1013	S10			
H	Gehärteter Stahl	gehärtet und angelassen	50 HRC	-	H1			
		gehärtet und angelassen	55 HRC	-	H2			
		gehärtet und angelassen	60 HRC	-	H3			
	Gehärtetes Gusseisen	gehärtet und angelassen	55 HRC	-	H4			

Die Tabellenwerte sind Richtwerte.
Es kann notwendig sein, die Werte den jeweiligen Bearbeitungsumständen anzupassen.

Material group	Structure of the material groups and identification letters		Brinell hardness HB	Tensile strength Rm (N/mm ²)	Chipping group	Cutting speed V _c (m/min)		
						uncoated		
						AK20	AP40	CERMET
P	Unalloyed steel	C ≤ 0.25 % annealed	125	428	P1			
		C > 0.25 ... ≤ 0.55 % annealed	190	639	P2			
		C > 0.25 ... ≤ 0.55 % hardened and tempered	210	708	P3			
		C > 0.55 % annealed	190	639	P4			
		C > 0.55 % hardened and tempered	300	1013	P5			
		Machining steel (short-chipping) tempered	220	745	P6			
	Low alloyed steel	annealed	175	591	P7			
		hardened and tempered	300	1013	P8			
		hardened and tempered	380	1282	P9			
		hardened and tempered	430	1477	P10			
	High alloyed steel and high alloyed tool steel	annealed	200	675	P11			
		hardened	300	1013	P12			
		hardened	400	1361	P13			
	Stainless steel	ferritic / martensitic, annealed	200	675	P14			
		martensitic, hardened and tempered	330	1114	P15			
M	Stainless steel	austenitic, chilled	200	675	M1			
		austenitic, precipitation-hardened (PH)	300	1013	M2			
		austenitic-ferritic, Duplex	230	778	M3			
K	Malleable cast iron	ferritic	200	675	K1			
		pearlitic	260	867	K2			
	Cast iron	low tensile strength	180	602	K3			
		high tensile strength / austenitic	245	825	K4			
	Cast iron with nodular graphite	ferritic	155	518	K5			
		pearlitic	265	885	K6			
	GGV (CGI)		200	675	K7			
N	Aluminium alloys long chipping	not heat treatable	30	-	N1	Cutting data depends on form of the inserts		
		heat treatable, heat treated	100	343	N2			
	Casted aluminium alloys	≤ 12 % Si, not heat treatable	75	260	N3			
		≤ 12 % Si, aushärtbar, ausgehärtet	90	314	N4			
		> 12 % Si, not heat treatable	130	447	N5			
	Magnesium alloys		70	250	N6			
	Copper and copper alloys (Brass / Bronze)	Unalloyed, elektrolyte copper	100	343	N7			
		Brass, Bronze	90	314	N8			
		Cu-alloys, short-chipping	110	382	N9			
		High-tensile, Ampco	300	1013	N10			
	Non-ferrous materials	Lead alloys (without abrasive filling material)	-	-	N11			
Duroplastic (without abrasive filling material)		-	-	N12				
Plastic glas fibre reinforced GFRP		-	-	N13				
Plastic carbon fibre reinforced CFRP		-	-	N14				
Plastic aramid fibre reinforced AFRP		-	-	N15				
Graphite (tech.)		80 Shore	-	N16				
S	High temperature resistant alloys	Fe-Basis	annealed	200	675	S1		
			heat treated	280	943	S2		
		Ni- or Co-alloyed	annealed	250	839	S3		
			heat treated	350	1177	S4		
			casting	320	1076	S5		
	Titanium alloys	Pure titan	200	675	S6			
		α- and β-alloys, heat treated	375	1262	S7			
		β-alloys	410	1396	S8			
	Wolfram alloys		300	1013	S9			
	Molybdän alloys		300	1013	S10			
H	Hardened steel	hardened	50 HRC	-	H1			
		hardened	55 HRC	-	H2			
		hardened	60 HRC	-	H3			
	Hardened cast iron	hardened	55 HRC	-	H4			

The recommended cutting data are only approximate values. It may be necessary to adjust them to each individual machining application.

Gruppo materiale	Struttura dei gruppi di materiali e lettere di riferimento		Durezza Brinell	Resistenza Rm (N/mm ²)	Gruppo di lavoro	Velocità di taglio V _c (m/min)		
						non rivestito		
						AK20	AP40	CERMET
P	Acciai non legato	C ≤ 0,25 % ricotto	125	428	P1			
		C > 0,25 ... ≤ 0,55 % ricotto	190	639	P2			
		C > 0,25 ... ≤ 0,55 % bonificato	210	708	P3			
		C > 0,55 % ricotto	190	639	P4			
		C > 0,55 % bonificato	300	1013	P5			
	Acciai debolmente legati	Acciaio (truciolo corto) ricotto	220	745	P6			
		ricotto	175	591	P7			
		bonificato	300	1013	P8			
		bonificato	380	1282	P9			
		bonificato	430	1477	P10			
	Acciai fortemente legati e acciai da utensili	ricotto	200	675	P11			
		temprato e rinvenuto	300	1013	P12			
		temprato e rinvenuto	400	1361	P13			
	Acciai inossidabili	ferritico / martensitico, ricotto	200	675	P14			
		martensitico, bonificato	330	1114	P15			
M	Acciai inossidabili	austenitico, trattato o temperato	200	675	M1			
		austenitico, indurimento per precipitazione (PH)	300	1013	M2			
		austenitico-ferritico, Duplex	230	778	M3			
K	Ghisa temprata	ferritico	200	675	K1			
		perlitica	260	867	K2			
	Ghisa grigia	bassa resistenza	180	602	K3			
		alta resistenza / austenitico	245	825	K4			
	Ghisa sferoidale	ferritico	155	518	K5			
		perlitica	265	885	K6			
GGV (CGI)		200	675	K7				
N	Leghe di Alluminio stampato	non invecchiato	30	-	N1	I parametrie die taglio dipendono dal profilo dell' inserto		
		rinvenuto, invecchiato	100	343	N2			
	Leghe di Alluminio da fusione	≤ 12 % Si, non invecchiato	75	260	N3			
		≤ 12 % Si, rinvenuto, invecchiato	90	314	N4			
		> 12 % Si, non invecchiato	130	447	N5			
	Leghe di magnesio		70	250	N6			
	Rame e Leghe di Rame (Bronzo / Ottone)	Non legati, Rame Elettrolitico	100	343	N7			
		Ottone, Bronzo	90	314	N8			
		Leghe Cu, truciolo corto	110	382	N9			
		Alta resistenza, Ampco	300	1013	N10			
	Materiali non metallici	Leghe al piombo (senza materiale di riempimento abrasivo)	-	-	N11			
		Duroplastico (senza materiale di riempimento abrasivo)	-	-	N12			
		Plastica rinforzata in fibra di vetro GFRP	-	-	N13			
		Plastica rinforzata in fibra di carbonio CFRP	-	-	N14			
		Plastica rinforzata in fibra aramidica AFRP	-	-	N15			
		Grafite (tecnico)	80 Shore	-	N16			
S	Leghe resistenti al calore	Base-Fe ricotto	200	675	S1			
		Base-Fe invecchiato	280	943	S2			
		Base Ni o Co ricotto	250	839	S3			
		Base Ni o Co invecchiato	350	1177	S4			
		Base Ni o Co da fusione	320	1076	S5			
	Leghe di Titanio	Titanio puro	200	675	S6			
		Leghe α e β, invecchiato	375	1262	S7			
		Leghe β	410	1396	S8			
	Leghe di tungsteno		300	1013	S9			
	Leghe di molibdeno		300	1013	S10			
H	Acciaio Temprato	temprato e rinvenuto	50 HRC	-	H1			
		temprato e rinvenuto	55 HRC	-	H2			
		temprato e rinvenuto	60 HRC	-	H3			
	Ghisa Temprata	temprato e rinvenuto	55 HRC	-	H4			

I dati indicati in tabella sono valori approssimati. Può essere necessario adattarli alle singole applicazioni di lavorazione.

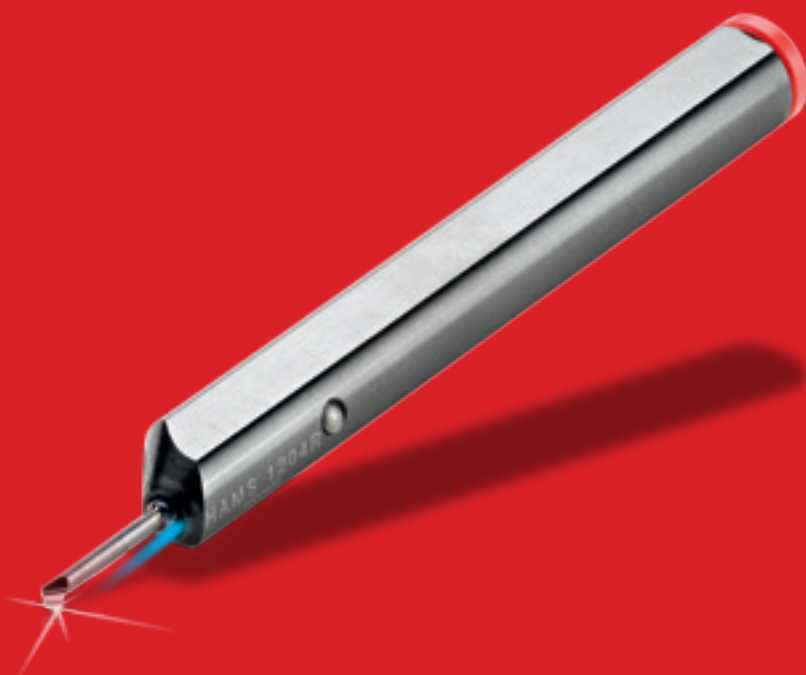

AMS ARNO®-Mini-System	<i>AMS</i> <i>ARNO®-Mini-System</i>	AMS ARNO®-Mini-System	
Innenbearbeitungssystem	<i>Internal machining system</i>	Sistema di lavorazione interna	
• Systemvorstellung	• <i>Introduction</i>	• Caratteristiche del sistema	352 – 353
• Klemmhalter	• <i>Holders</i>	• Adattatori	354 – 369
– Werkzeugauswahl	– <i>Tool shank options</i>	– Tipologie di corpo utensile	354 – 357
– Bezeichnungssystem	– <i>Designation system</i>	– Sistema di identificazione	358
– Klemmhalter	– <i>Holders</i>	– Adattatori	359 – 369
• Schneideinsätze	• <i>Inserts</i>	• Inserti	371 – 398
– Sortenbeschreibung	– <i>Grade description</i>	– Descrizione delle Qualità	371
– Schneideinsätze	– <i>Inserts</i>	– Inserti	372 – 398
• Ersatzteile und Zubehör	• <i>Spare parts and accessories</i>	• Ricambi e accessori	402
• Schnittwerte	• <i>Cutting data</i>	• Parametri di taglio	403 – 406
• Anwendungshinweise	• <i>Application reference</i>	• Suggestimenti tecnici	407 – 408

ARNO®-Mini-System

Durchmesser ab 0,7 mm, Bohrtiefe bis 50 mm

ARNO® Mini-System

Diameter from 0.7 mm, depth up to 50 mm

ARNO® Mini-System

Diametri da 0,7 mm, profondità
del foro massima fino a 50 mm



7

Systemvorstellung

AMS ist ein modulares System zur flexiblen Bohrungsbearbeitung ab Durchmesser 0,7 mm mit maximaler Bohrungstiefe bis zu 50 mm (abhängig von der Bearbeitung). Durch die geschliffene Schräge am Schaft des Schneideinsatzes und den fixierten Anschlagstift im Halter wird eine exakte Bestimmung der Länge sowie eine garantierte Wiederholgenauigkeit der Spitzenhöhe erreicht. Der Kegel des Gewindestiftes ermöglicht eine sichere Spannung und reduziert somit die auftretenden Schwingungen im Schneidenbereich. Das Ergebnis ist maximale Stabilität für prozesssichere Bohrungsbearbeitung.

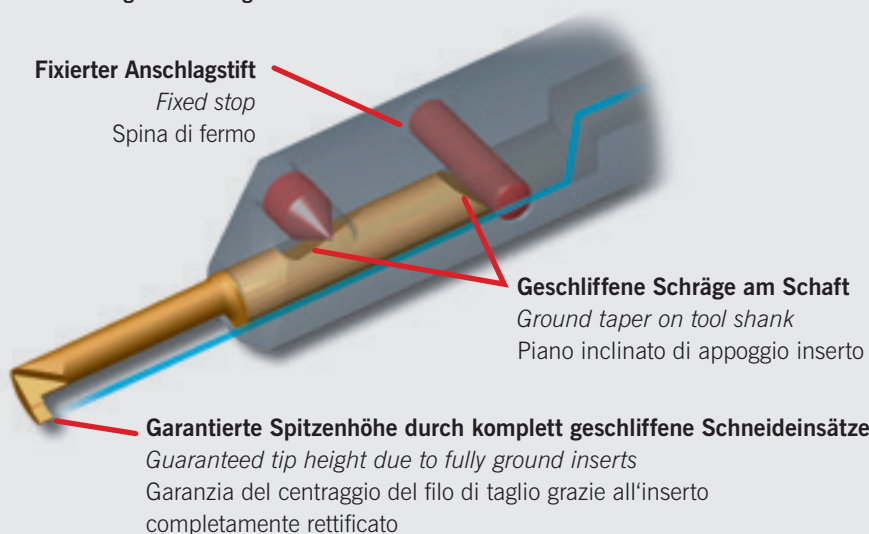

Fakten

- Bohrungen Ausdrehen ab Durchmesser 0,7 mm
- Einstechen ab Breite 0,8 mm
- Radieneinstich ab R 0,5 mm
- Rückwärtsdrehen und Fasen
- Vorstechen und Fasen
- Zentrum Fasen
- Kopieren
- Gewindedrehen ab M3
- Axial-Stechen ab Durchmesser 5 mm
- Seegering DIN 471/472

Introduction

AMS is a modular boring system starting at D_{min} 0.7 mm with a maximum reach of 50 mm (depending on application). With the ground taper on the tool shank and the fixed stop in the sleeve the length remains accurately constant and guaranteed cutting edge repeatability is achieved. The cone of the threaded pin ensures secure tool locking and reduces cutting edge vibrations.

Features

- Boring from diameter 0.7 mm
- Groove width starting at 0.8 mm
- Full radius grooving starting at R 0.5 mm
- Back turning and chamfering
- Pre-grooving and chamfering
- Centre chamfering
- Copying
- Threading from M3
- Face grooving starting at \varnothing 5 mm
- Cir-clip DIN 471/472

Descrizione

AMS è un sistema modulare per una lavorazione flessibile da diametri di 0,7 mm con profondità del foro massima fino a 50 mm (in base alla lavorazione). Il gambo rettificato ed il piano di fermo garantiscono perfetta ripetibilità di posizione ed altezza del filo di taglio. Il metodo di bloccaggio garantisce un bloccaggio sicuro e privo di vibrazioni.

Caratteristiche

- Lavorazione fori da diametro 0,7 mm
- Gole da larghezza 0,8 mm
- Raggio da R 0,5 mm
- Pre-scanalatura e smusso
- Lavorazione in tirata
- Smussatura centrale
- Copiatura
- Filettatura da M3
- Gole assiali da diametro 5 mm
- Sedi Seeger DIN 471/472

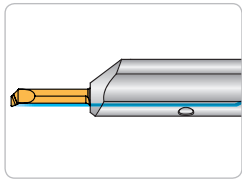
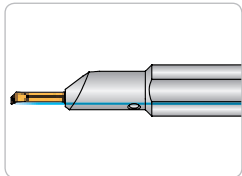
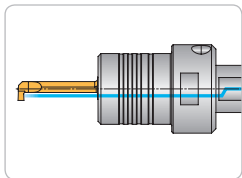
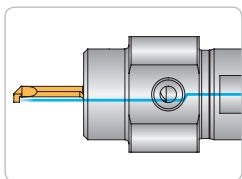
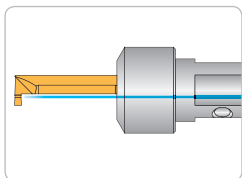
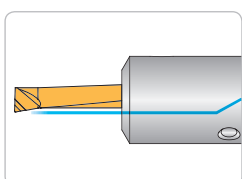
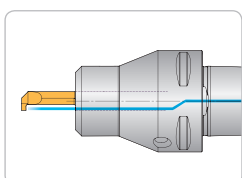
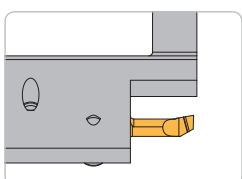
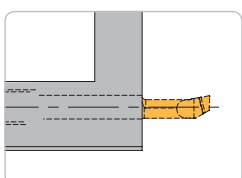
Übersicht Klemmhalter und Schneideinsätze / Program overview holders and inserts /
Gamma prodotti adattatori e inserti**Klemmhalter – Standard***Holder – Standard*
Stelo – StandardKlemmhalter Seite/Holders page/Adattatori pagina **359** / Schneideinsätze Seite/Inserts page/Inserti pagina **372 – 396****Klemmhalter – Abgesetzt***Holder – Off-set*
Stelo – Off-SetKlemmhalter Seite/Holders page/Adattatori pagina **360** / Schneideinsätze Seite/Inserts page/Inserti pagina **372 – 396****Hydro-Dehn Klemmhalter***Hydraulic Holder*
Adattatore idrauliciKlemmhalter Seite/Holders page/Adattatori pagina **361** / Schneideinsätze Seite/Inserts page/Inserti pagina **372 – 396****Klemmhalter für STAR-Drehmaschinen***Holders for STAR – lathes*
Utensile di finitura per torni STARKlemmhalter Seite/Holders page/Adattatori pagina **362** / Schneideinsätze Seite/Inserts page/Inserti pagina **372 – 396****Klemmhalter für Drehmaschinen***Holders for lathes*
Adattatori per torniKlemmhalter Seite/Holders page/Adattatori pagina **363** / Schneideinsätze Seite/Inserts page/Inserti pagina **372 – 396****Klemmhalter zum Ausspindeln***Holders for finishing*
Adattatori corti per contromandrinoKlemmhalter Seite/Holders page/Adattatori pagina **365** / Schneideinsätze Seite/Inserts page/Inserti pagina **372 – 396****NEU: Klemmhalter mit Polygonschaft***NEW: Holders with Polygon-Shank*
NUOVO: Adattatori con attacco poligonaleKlemmhalter Seite/Holders page/Adattatori pagina **366** / Schneideinsätze Seite/Inserts page/Inserti pagina **372 – 396****Klemmhalter für Langdrehmaschinen und Mehrspindler***Adattatori per fantina mobile e plurimandrino*
Holders for sliding head auto lathes and multi spindle machinesKlemmhalter Seite/Holders page/Adattatori pagina **367** / Schneideinsätze Seite/Inserts page/Inserti pagina **372 – 396****Klemmhalter für Langdrehmaschinen an Gegenspindel***Holder for sliding head lathes on counter spindle*
Adattatori per torni a fantina mobile su contromandrinoKlemmhalter Seite/Holders page/Adattatori pagina **368** / Schneideinsätze Seite/Inserts page/Inserti pagina **372 – 396**

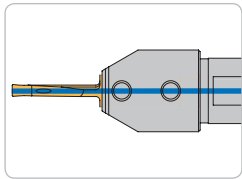
Übersicht Klemmhalter und Schneideinsätze / Program overview holders and inserts /
Gamma prodotti adattatori e inserti**Klemmhalter SAV - Axial Stechen***Holder SAV – Axial grooving*

Adattatori SAV – Scanalatura assiale

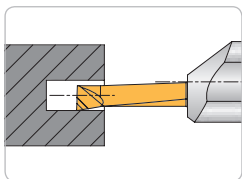
Klemmhalter Seite/Holders page/Adattatori pagina **369** / Schneideinsätze Seite/Inserts page/Inserti pagina **397 – 398****Schneideinsätze** / Inserts / Inserti**Drehen***Turning*

Barenatura

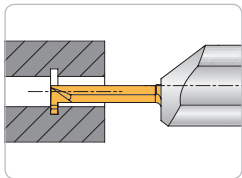
Klemmhalter Seite/Holders page/Adattatori pagina **359 – 368** / Schneideinsätze Seite/Inserts page/Inserti pagina **372****Stechen***Grooving*

Scanalatura

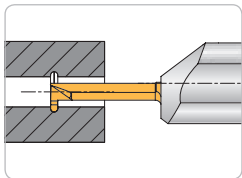
Klemmhalter Seite/Holders page/Adattatori pagina **359 – 368** / Schneideinsätze Seite/Inserts page/Inserti pagina **374****Radius-Einstich***Radius grooving*

Profilo a raggio pieno

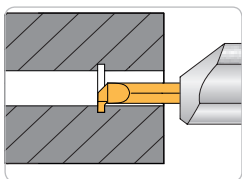
Klemmhalter Seite/Holders page/Adattatori pagina **359 – 368** / Schneideinsätze Seite/Inserts page/Inserti pagina **375****Seegering DIN 471/472***Cir-clip DIN 471/472*

Sedi seeger DIN 471/472

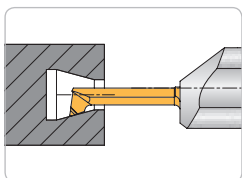
Klemmhalter Seite/Holders page/Adattatori pagina **359 – 368** / Schneideinsätze Seite/Inserts page/Inserti pagina **376****Kopieren***Copying*

Copiatura

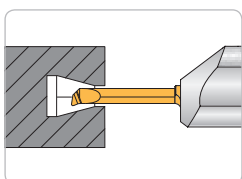
Klemmhalter Seite/Holders page/Adattatori pagina **359 – 368** / Schneideinsätze Seite/Inserts page/Inserti pagina **378****Kopieren – verstärkte Ausführung***Copying – Re-inforced execution*

Copiatura – Versione rinforzata

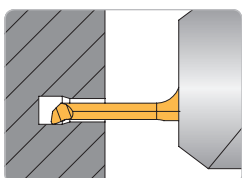
Klemmhalter Seite/Holders page/Adattatori pagina **359 – 368** / Schneideinsätze Seite/Inserts page/Inserti pagina **380****Kopieren - versetzte und verstärkte Ausführung***Copying - offset and reinforced version*

Copiatura - versione disassata e rinforzata

Klemmhalter Seite/Holders page/Adattatori pagina **359 – 368** / Schneideinsätze Seite/Inserts page/Inserti pagina **381**

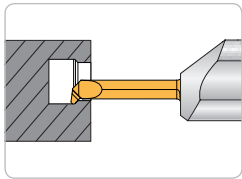
Übersicht Klemmhalter und Schneideinsätze / Program overview holders and inserts /
Gamma prodotti adattatori e inserti**Kopieren 45°**

Copying 45°
Copiatura 45°

Klemmhalter Seite/Holders page/Adattatori pagina **359 – 368** / Schneideinsätze Seite/Inserts page/Inserti pagina **382**

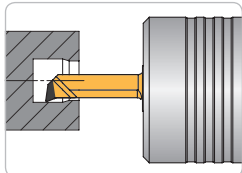
**Kopieren – CBN bestückt**

Copy turning – CBN brazed
Copiatura – riporto CBN

Klemmhalter Seite/Holders page/Adattatori pagina **359 – 368** / Schneideinsätze Seite/Inserts page/Inserti pagina **383**

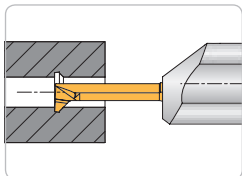
**Vorstechen und Fasen**

Pre-grooving and chamfering
Pre-scanalatura e smusso

Klemmhalter Seite/Holders page/Adattatori pagina **359 – 368** / Schneideinsätze Seite/Inserts page/Inserti pagina **384**

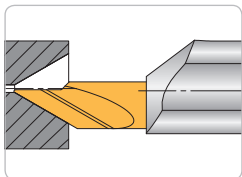
**Zentrum Fasen 45°/60°**

Centre chamfering 45°/60°
Smussatura centrale 45°/60°

Klemmhalter Seite/Holders page/Adattatori pagina **359 – 368** / Schneideinsätze Seite/Inserts page/Inserti pagina **385**

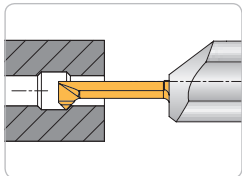
**Fasen 45°**

Chamfering 45°
Smusso 45°

Klemmhalter Seite/Holders page/Adattatori pagina **359 – 368** / Schneideinsätze Seite/Inserts page/Inserti pagina **386**

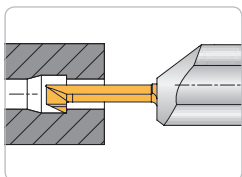
**Rückwärtsdrehen**

Back turning
Lavorazione in tirata

Klemmhalter Seite/Holders page/Adattatori pagina **359 – 368** / Schneideinsätze Seite/Inserts page/Inserti pagina **387**

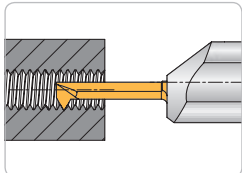
**Gewinde 60° – Metrisch-Teilprofil**

Threading 60° – Metric partial profile
Filettatura 60° – Metrica profilo parziale

Klemmhalter Seite/Holders page/Adattatori pagina **359 – 368** / Schneideinsätze Seite/Inserts page/Inserti pagina **388**

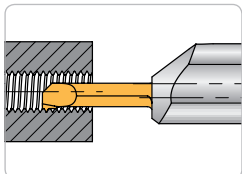
**Gewinde 60° – Metrisch-Vollprofil**

Threading 60° – Metric full profile
Filettatura 60° – Metrica profilo completo

Klemmhalter Seite/Holders page/Adattatori pagina **359 – 368** / Schneideinsätze Seite/Inserts page/Inserti pagina **389**

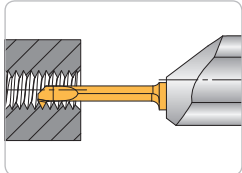
**Whitworth Gewinde 55° – Teilprofil**

Whitworth thread 55° – Partial profile
Filettatura Whitworth 55° – Profilo parziale

Klemmhalter Seite/Holders page/Adattatori pagina **359 – 368** / Schneideinsätze Seite/Inserts page/Inserti pagina **390**

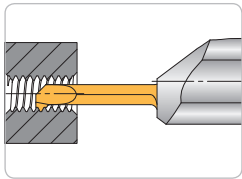
Übersicht Klemmhalter und Schneideinsätze / Program overview holders and inserts /
Gamma prodotti adattatori e inserti**Whitworth Rohrgewinde 55° DIN-ISO 228 – Vollprofil***Whitworth pipe thread 55° DIN ISO 228 – Full profile*

Filettatura Whitworth 55° DIN ISO 228 – Profilo completo

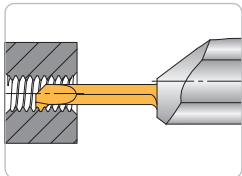
Klemmhalter Seite/Holders page/Adattatori pagina **359 – 368** / Schneideinsätze Seite/Inserts page/Inserti pagina **391****Whitworth Rohrgewinde 55° BSW – Vollprofil***Whitworth pipe thread 55° BSW – Full profile*

Filettatura Whitworth 55° BSW – Profilo completo

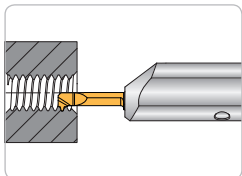
Klemmhalter Seite/Holders page/Adattatori pagina **359 – 368** / Schneideinsätze Seite/Inserts page/Inserti pagina **392****Trapezgewinde 30° DIN-ISO 103 – Teilprofil***Trapezoidal 30° DIN ISO 103 – Partial profile*

Filettatura Trapezoidale 30° DIN ISO 103 – Profilo parziale

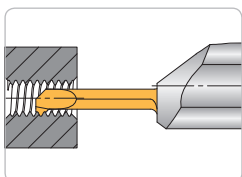
Klemmhalter Seite/Holders page/Adattatori pagina **359 – 368** / Schneideinsätze Seite/Inserts page/Inserti pagina **393****Amerikanisches ISO-Zollgewinde 60° UN – Vollprofil***American standard thread 60° UN – full profile*

Filettatura Americana standard 60° UN – Profilo completo

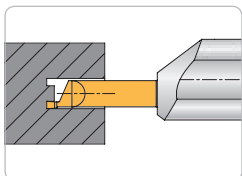
Klemmhalter Seite/Holders page/Adattatori pagina **359 – 368** / Schneideinsätze Seite/Inserts page/Inserti pagina **394****Axial-Stecken***Axial grooving*

Scanalatura assiale

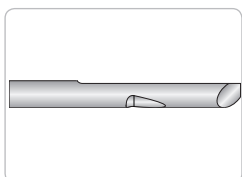
Klemmhalter Seite/Holders page/Adattatori pagina **359 – 368** / Schneideinsätze Seite/Inserts page/Inserti pagina **395****Halbzeuge zur Eigenprofilierung***Blanks for special profiles*

Semilavorato per la realizzazione di speciali

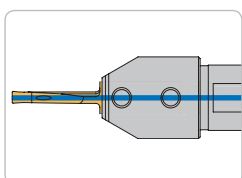
Klemmhalter Seite/Holders page/Adattatori pagina **359 – 368** / Schneideinsätze Seite/Inserts page/Inserti pagina **396****SAV – Axial-Stecken***SAV – Axial grooving*

SAV – Scanalatura assiale

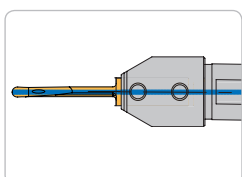
Klemmhalter Seite/Holders page/Adattatori pagina **369** / Schneideinsätze Seite/Inserts page/Inserti pagina **397****SAV – Axial Stecken - Vollradiusausführung***SAV – Axial grooving - Full radius execution*

SAV – Scanalatura assiale - Esecuzione a raggio completo

Klemmhalter Seite/Holders page/Adattatori pagina **369** / Schneideinsätze Seite/Inserts page/Inserti pagina **398**

Klemmhalter / Holders / Adattatori

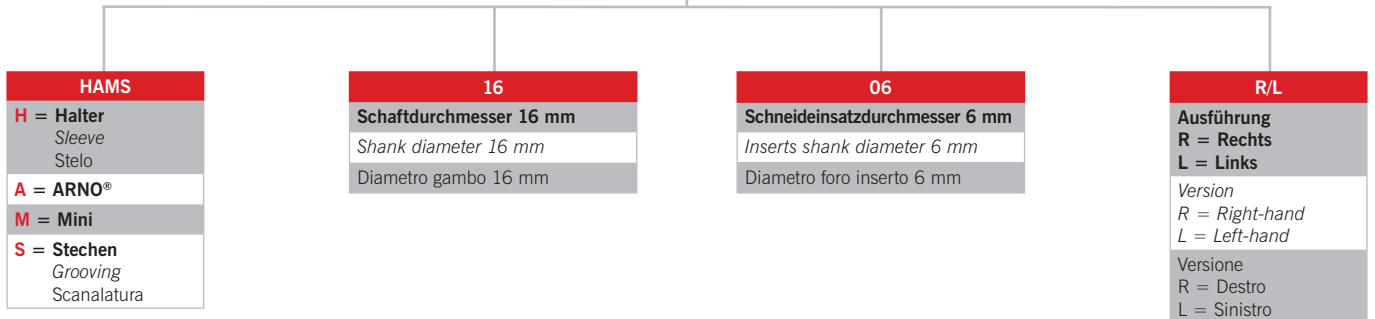

Schneideinsätze / Inserts / Inserti

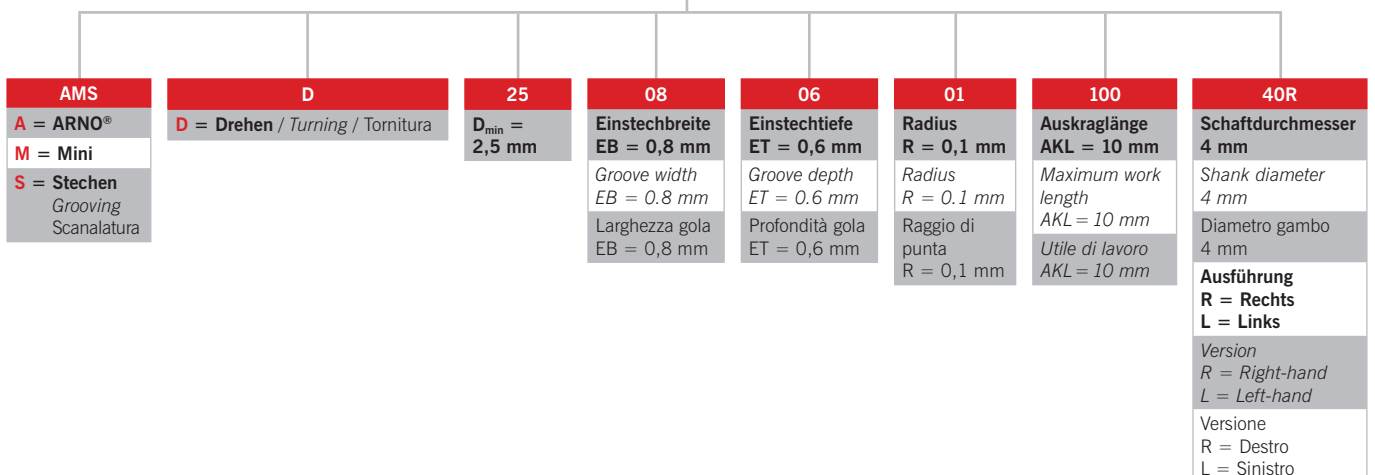

Klemmhalter - Standard / Holder - Standard / Stelo - Standard

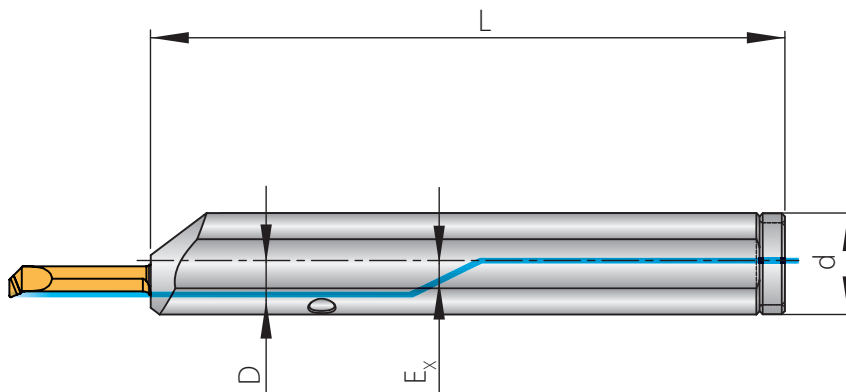

Rechte Ausführung abgebildet
Right-hand execution shown
Versione destra in figura

Trägerwerkzeuge / Holders / Utensili

Bezeichnung Designation Articolo	D	d	L	E _x	PG 44	Schneideinsatz Insert Inserto
HAMS 1204L/R	4	12	100	2,35	●	AMS...40L/R
HAMS 1206L/R	6	12	100	2,35	●	AMS...60L/R
HAMS 1606L/R	6	16	120	2,80	●	AMS...60L/R
HAMS 1608L/R	8	16	120	2,80	●	AMS...80L/R
HAMS 2010R	10	20	120	2,80	●	AMS...100R

Hinweis: Auf diese Halter passen alle Schneideinsätze von den Seiten 372 bis 396. Maß „D“ beachten!

Remark: The inserts for these holders you will find on pages 372 to 396. Note measurement "D"!

Nota: Inserti per questi adattatori a pagg da 372 a 396. Fare attenzione alla misura "D"!

Ersatzteile / Spare Parts / Ricambi

Trägerwerkzeug Holder Utensile	Schraube Screw Vite	Schlüssel Key Chiave	Kühlmittelsverschlussring Coolant seal ring Anello tenuta refrigerante
HAMS 1204 ..-HAMS 1206 ..	AS 0043	KP3111	KVR 12
HAMS 1606 ..-HAMS 1608 ..	AS 0044	KP1111	KVR 16
HAMS 2010 ..	AS 0044	KP1111	KVR 20



Klemmhalter - Abgesetzt / Holder - Off-set / Selo - Scaricato

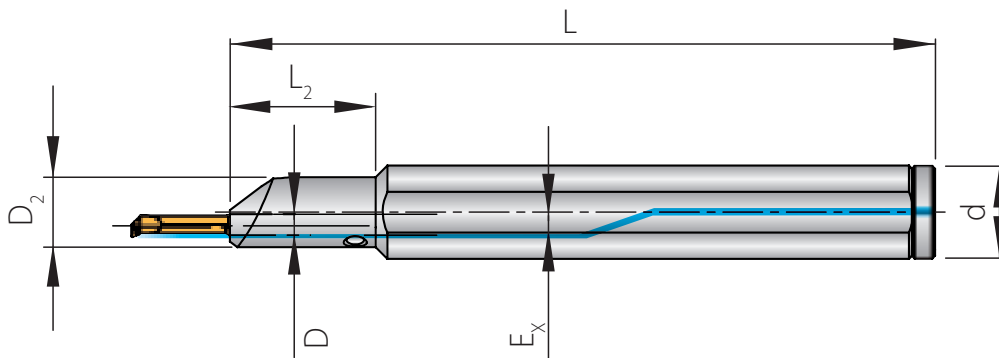

Rechte Ausführung abgebildet
Right-hand execution shown
Versione destra in figura

Trägerwerkzeuge / Holders / Utensili

Bezeichnung Designation Articolo	D	D ₂	d	L	L ₂	E _x	PG 44	Schneideinsatz Insert Inserto
HAMS 1604L/R	4	12	16	120	25	2,35	●	AMS...40L/R

Hinweis: Auf diese Halter passen alle Schneideinsätze von den Seiten 372 bis 396. Maß „D“ beachten!

Remark: The inserts for these holders you will find on pages 372 to 396. Note measurement "D"!

Nota: Inserti per questi adattatori a pagg da 372 a 396. Fare attenzione alla misura "D"!

Ersatzteile / Spare Parts / Ricambi

Trägerwerkzeug Holder Utensile	Schraube Screw Vite	Schlüssel Key Chiave	Kühlmittelverschlussring Coolant seal ring Anello tenuta refrigerante
HAMS 1604 ..	AS 0043	KP3111	KVR 16

Hydro-Dehn Klemmhalter / Hydraulic Holder / Adattatore idraulici

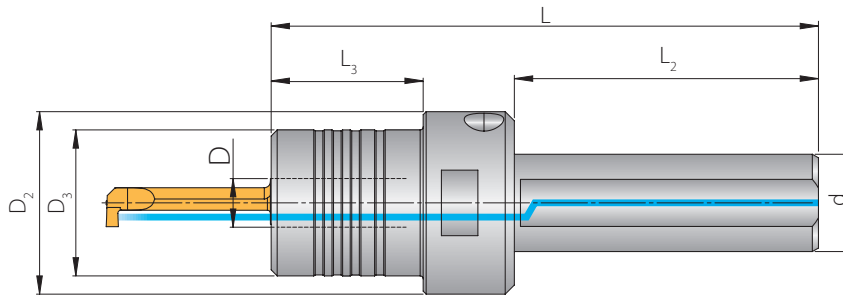

d = Schaftdurchmesser [mm]
d = Shank diameter [mm]
d = Diametro accoppiamento [mm]

Trägerwerkzeuge / Holders / Utensili

Bezeichnung Designation Articolo	D	D ₂	D ₃	d	L	L ₂	L ₃	PG 47	Schneideinsatz Insert Inserto
HAMS 1604R-HYD.	4	30	18	16	82,5	50	18	●	AMS...40R
HAMS 1606R-HYD.	6	30	20	16	90,0	50	25	●	AMS...60R
HAMS 1608R-HYD.	8	30	24	16	90,0	50	25	●	AMS...80R

Hinweis: Auf diese Halter passen alle Schneideinsätze von den Seiten 372 bis 396. Maß „D“ beachten!

Remark: The inserts for these holders you will find on pages 372 to 396. Note measurement "D"!

Nota: Inserti per questi adattatori a pagg da 372 a 396. Fare attenzione alla misura "D"!

Special holder
Adattatore speciali

Klemmhalter für STAR-Drehmaschinen / Holder for STAR-lathes / Adattatore per STAR-torni

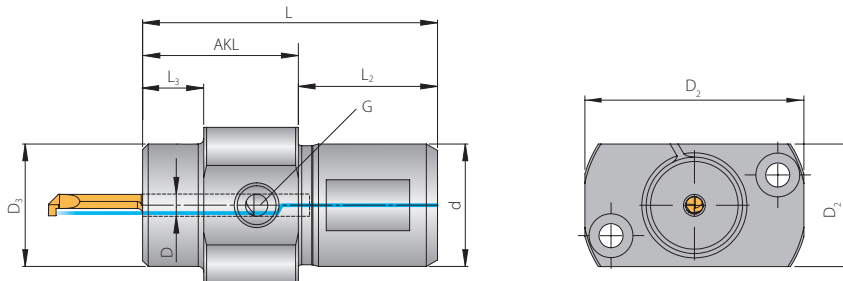

AKL = Auskraglänge [mm]
d = Schaftdurchmesser [mm]
AKL = Maximum work length [mm]
d = Shank diameter [mm]
AKL = Utile di lavoro [mm]
d = Diametro accoppiamento [mm]



Trägerwerkzeuge / Holders / Utensili

Bezeichnung Designation Articolo	D	D ₂	D ₃	d	AKL	L	L ₂	L ₃	G	PG 44	Schneideinsatz Insert Inserto
HAMS 2204-A28-SR	4	28 x 50	22	22	28	53	25	11	M8x1	●	AMS...40R
HAMS 2204-A50-S2-SR	4	28 x 50	22	22	50	75	25	33	G 1/8	●	AMS...40R
HAMS 2206-A33-SR	6	28 x 50	22	22	28	53	25	16	M8x1	●	AMS...60R
HAMS 2206-A50-S2-SR	6	28 x 50	22	22	50	75	25	33	G 1/8	●	AMS...60R
HAMS 3004-A28-SR	4	28 x 50	22	30	28	53	25	11	M8x1	●	AMS...40R
HAMS 3204-A28-SR	4	28 x 50	22	32	28	53	25	11	M8x1	●	AMS...40R

Hinweis: Auf diese Halter passen alle Schneideinsätze von den Seiten 372 bis 396. Maß „D“ beachten!

Remark: The inserts for these holders you will find on pages 372 to 396. Note measurement "D"!

Nota: Inserti per questi adattatori a pagg da 372 a 396. Fare attenzione alla misura "D"!

Ersatzteile / Spare Parts / Ricambi

Trägerwerkzeug Holder Utensile	Schraube Screw Vite	Schlüssel Key Chiave
HAMS 2204..-HAMS 3204..	AS 0044	KP1111



Special holder
Adattatore speciali

Klemmhalter für Drehmaschinen / Holders for lathes / Adattatori per torni

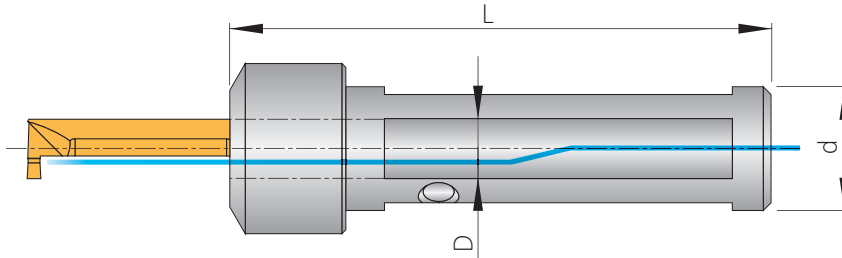

d = Schaftdurchmesser [mm]
d = Shank diameter [mm]
d = Diametro accoppiamento [mm]

Trägerwerkzeuge / Holders / Utensili

CITIZEN

Bezeichnung Designation Articolo	D	d	L	Anschluss Connection Filetto	PG 44	Schneideinsatz Insert Inserto
HAMS 1"04-CR	4	1"	100	G 1/4"	●	AMS...40R
HAMS 1"06-CR	6	1"	100	G 1/4"	●	AMS...60R
HAMS 1"08-CR	8	1"	100	G 1/4"	●	AMS...80R
HAMS 3/4"04-CR	4	3/4"	100	G 1/8"	●	AMS...40R
HAMS 3/4"06-CR	6	3/4"	100	G 1/8"	●	AMS...60R
HAMS 3/4"08-CR	8	3/4"	100	G 1/8"	●	AMS...80R

STAR

Bezeichnung Designation Articolo	D	d	L	Anschluss Connection Filetto	PG 44	Schneideinsatz Insert Inserto
HAMS 1604-SR	4	16	70	G 1/8"	●	AMS...40R
HAMS 1606-SR	6	16	70	G 1/8"	●	AMS...60R
HAMS 1608-SR	8	16	70	G 1/8"	●	AMS...80R
HAMS 2204-SR	4	22	110	G 1/8"	●	AMS...40R
HAMS 2204-SR G1/4"	4	22	110	G 1/4"	●	AMS...40R
HAMS 2206-SR	6	22	110	G 1/8"	●	AMS...60R
HAMS 2206-SR G1/4"	6	22	110	G 1/4"	●	AMS...60R
HAMS 2208-SR	8	22	110	G 1/8"	●	AMS...80R

TORNOS, TSUGAMI, HANWA

Bezeichnung Designation Articolo	D	d	L	Anschluss Connection Filetto	PG 44	Schneideinsatz Insert Inserto
HAMS 2004-TOR	4	20	90	G 1/8"	●	AMS...40R
HAMS 2006-TOR	6	20	90	G 1/8"	●	AMS...60R
HAMS 2008-TOR	8	20	90	G 1/8"	●	AMS...80R
HAMS 2504-TOR	4	25	100	G 1/8"	●	AMS...40R
HAMS 2506-TOR	6	25	100	G 1/8"	●	AMS...60R
HAMS 2508-TOR	8	25	100	G 1/8"	●	AMS...80R

Ersatzteile / Spare Parts / Ricambi

Trägerwerkzeug Holder Utensile	Schraube Screw Vite	Schlüssel Key Chiave
HAMS 1"...-HAMS 3/4"..	AS 0044	KP1111
HAMS 1604..	AS 0044	KP1111
HAMS 1606 - HAMS 1608..	AS 0044	KP1111
HAMS 2004...-HAMS 2508..	AS 0044	KP1111

Special holder
Adattatore speciali

Klemmhalter für Drehmaschinen / Holders for lathes / Adattatori per torni

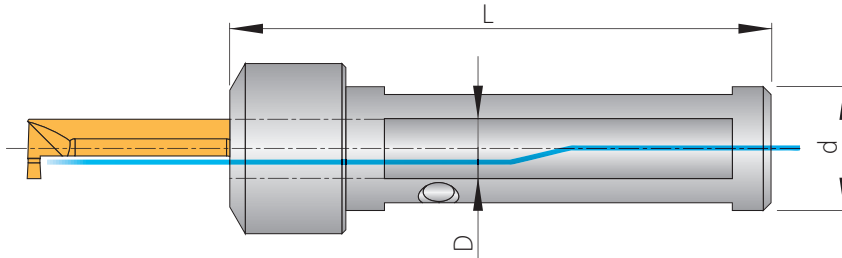

d = Schaftdurchmesser [mm]
d = Shank diameter [mm]
d = Diametro accoppiamento [mm]

TRAUB

Bezeichnung Designation Articolo	D	d	L	Anschluss Connection Filetto	PG 44	Schneideinsatz Insert Inserto
HAMS 2804-TR	4	28	120	G 1/4"	●	AMS...40R
HAMS 2806-TR	6	28	120	G 1/4"	●	AMS...60R

Halter mit 2 Spannflächen = CITIZEN, TORNOS, TRAUB, TSUGAMI und HANWA.

Halter mit 4 Spannflächen = STAR.

Holders with 2 flats = CITIZEN, TORNOS, TRAUB, TSUGAMI and HANWA.

Holders with 4 flats = STAR.

Adattatore con 2 piani di bloccaggio = CITIZEN, TORNOS, TRAUB, TSUGAMI und HANWA.

Adattatore con 4 piani di bloccaggio = STAR.

Hinweis: Auf diese Halter passen alle Schneideinsätze von den Seiten 372 bis 396. Maß „D“ beachten!

Remark: The inserts for these holders you will find on pages 372 to 396. Note measurement "D"!

Nota: Inserti per questi adattatori a pagg da 372 a 396. Fare attenzione alla misura "D"!

Ersatzteile / Spare Parts / Ricambi

Trägerwerkzeug Holder Utensile	Schraube Screw Vite	Schlüssel Key Chiave
HAMS 2804..-HAMS 2806..	AS 0044	KP1111

7

Klemhalter zum Auspindeln / Holders for finishing / Adattatori corti per contromandrino

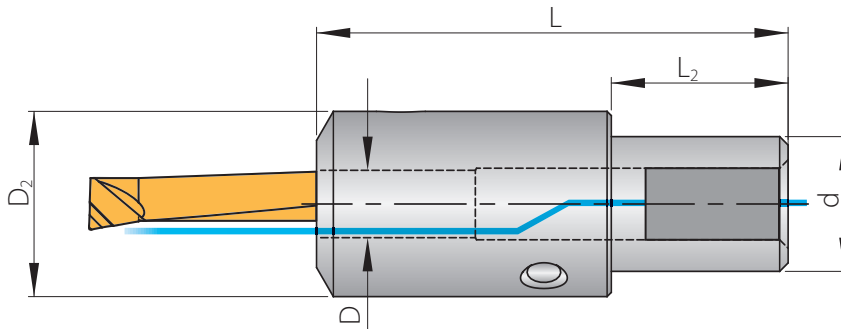

d = Schaftdurchmesser [mm]
 d = Shank diameter [mm]
 d = Diametro accoppiamento [mm]

Trägerwerkzeuge / Holders / Utensili

Bezeichnung Designation Articolo	D	D ₂	d	L	L ₂	PG 44	Schneideinsatz Insert Inserto
HAMS 1604-AR	4	22	16	56	21	●	AMS...40R
HAMS 1606-AR	6	22	16	56	21	●	AMS...60R
HAMS 1608-AR	8	22	16	56	21	●	AMS...80R

Hinweis: Auf diese Halter passen alle Schneideinsätze von den Seiten 372 bis 396. Maß „D“ beachten!

Remark: The inserts for these holders you will find on pages 372 to 396. Note measurement "D"!

Nota: Inserti per questi adattatori a pagg da 372 a 396. Fare attenzione alla misura "D"!

Ersatzteile / Spare Parts / Ricambi

Trägerwerkzeug Holder Utensile	Schraube Screw Vite	Schlüssel Key Chiave
HAMS 1604..-HAMS 1608..	AS 0044	KP1111



Special holder
Adattatore speciali

Klemmhalter mit Polygonschaft / Holders with Polygon-Shank / Adattatori con attacco poligonale

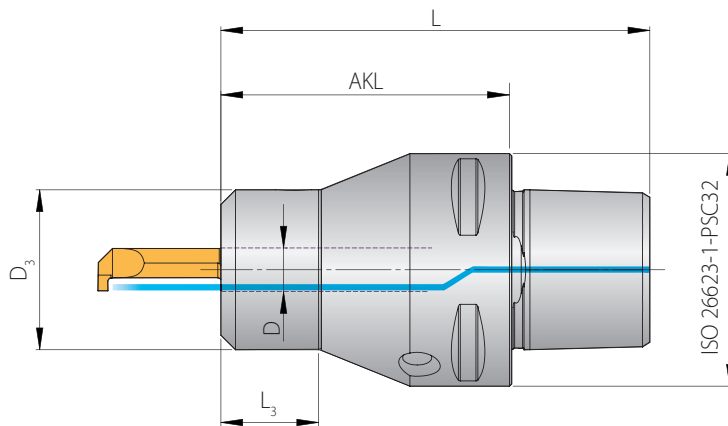

AKL = Auskraglänge [mm]
AKL = Maximum work length [mm]
AKL = Utile di lavoro [mm]

Rechte Ausführung abgebildet
Right-hand execution shown
Versione destra in figura

N NEU/NEW/
NUOVO

Trägerwerkzeuge / Holders / Utensili

Bezeichnung Designation Articolo	D	D ₃	L	AKL	L ₃	PG 44
HAMS PSC3206R N	6	22	59	40	13	●

Hinweis: Auf diese Halter passen alle Schneideinsätze von den Seiten 372 bis 396. Maß „D“ beachten!

Remark: The inserts for these holders you will find on pages 372 to 396. Note measurement "D"!

Nota: Inserti per questi adattatori a pagg da 372 a 396. Fare attenzione alla misura "D"!

Ersatzteile / Spare Parts / Ricambi

Trägerwerkzeug Holder Utensile	Schraube Screw Vite	Schlüssel Key Chiave
HAMS PSC32..	AS 0044	KP1111

7

Special holder
Adattatore speciali

Klemhalter für Langdrehmaschinen und Mehrspindler

Holder for sliding head auto lathes and multi spindle machines

Adattori per torni a fantina mobile e plurimandrino

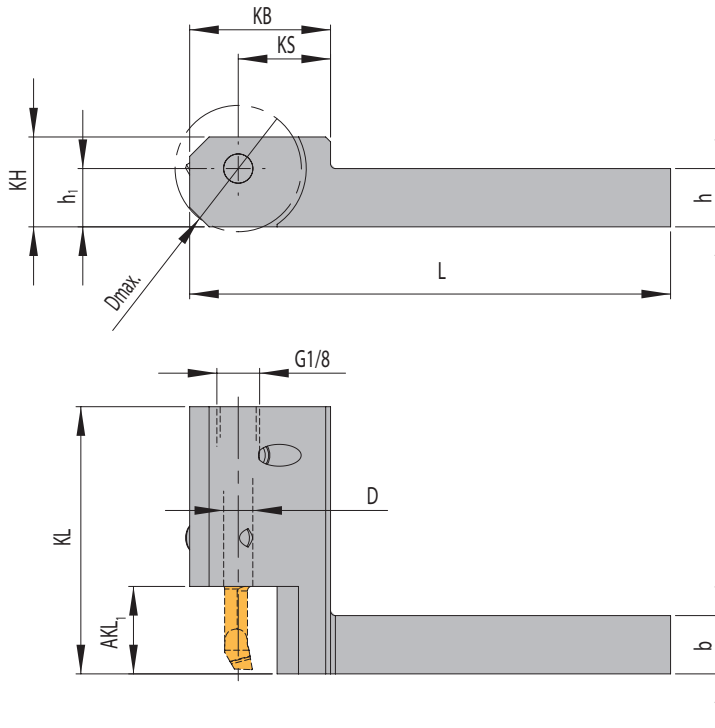

Trägerwerkzeuge / Holders / Utensili

Bezeichnung Designation Articolo	D	h	b	L	KB	KS	KL	AKL ₁	KH	h ₁	D _{max}	Anschluss Connection Filetto	PG 44	Schneideinsatz Insert Inserto
HAMS 121204-R	4	12	12	98	28	19	52,5	18	18,5	12	26	G 1/8"	●	AMS...40R
HAMS 121206-R	6	12	12	99	29	19	55,0	18	18,5	12	26	G 1/8"	●	AMS...60R

Dmax = Maximaler Durchmesser bei Vollmaterial

Dmax = Maximum diameter in solid

Dmax = Diametro massimo lavorazione dal pieno

Hinweis: Auf diese Halter passen alle Schneideinsätze von den Seiten 372 bis 396. Maß „D“ beachten!

Remark: The inserts for these holders you will find on pages 372 to 396. Note measurement "D"!

Nota: Inserti per questi adattatori a pagg da 372 a 396. Fare attenzione alla misura "D"!

Ersatzteile / Spare Parts / Ricambi

Trägerwerkzeug Holder Utensile	Schraube Screw Vite	Schlüssel Key Chiave
HAMS 12..04..	AS 0043	KP3111
HAMS 12..06..	AS 0044	KP1111

Special holder
Adattatore speciali

Klemhalter für Langdrehmaschinen an Gegenspindel

Holder for sliding head lathes on counter spindle

Adattori per torni a fantina mobile su contromandrino

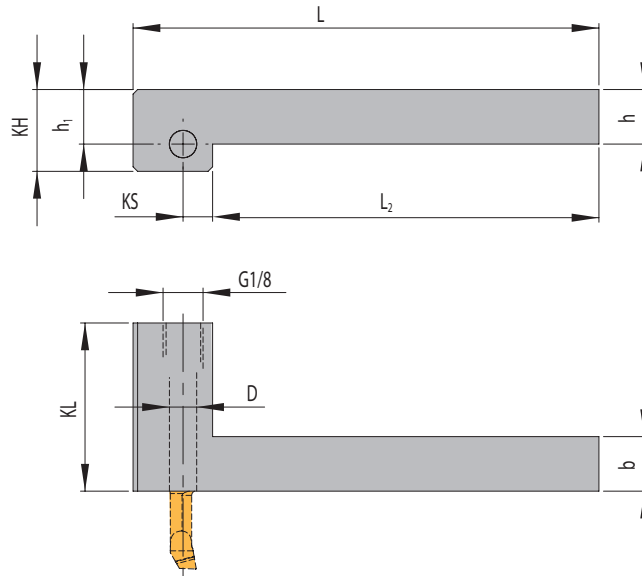

Trägerwerkzeuge / Holders / Utensili

Bezeichnung Designation Articolo	D	h	b	L	L ₂	KS	KL	KH	h ₁	Anschluss Connection Filetto	PG 44	Schneideinsatz Insert Inserto
HAMS 121206-R-GS	6	12	12	102,5	85	6,5	37	18	12	G 1/8"	●	AMS...60R

Hinweis: Auf diese Halter passen alle Schneideinsätze AMS-... .60R.

Information: please use AMS-... .60R for these holders.

Nota: utilizzare inserti AMS-...60R. con questi adattatori.

Ersatzteile / Spare Parts / Ricambi

Trägerwerkzeug Holder Utensile	Schraube Screw Vite	Schlüssel Key Chiave
HAMS 1206..	AS 0044	KP1111



Axial Stechen / Axial grooving / Scanalatura assiale

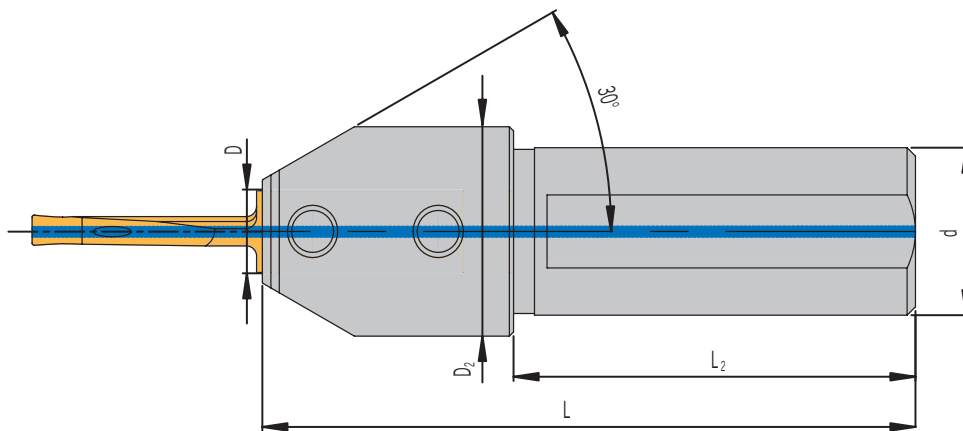

Mit innerer Kühlmittelzufuhr
With internal coolant
Con adduzione interna

Trägerwerkzeuge / Holders / Utensili

Bezeichnung Designation Articolo	D	D ₂	d	L	L ₂	PG 19	Schneideinsatz Insert Inserto
HSAV 2006	6	25	20	78	48	●	SAV15... SAV20...
HSAV 2008	8	25	20	78	48	●	SAV25... SAV30...
HSAV 2010	10	25	20	78	48	●	SAV40...
HSAV 2508	8	30	25	78	48	●	SAV25... SAV30...
HSAV 2510	10	30	25	78	48	●	SAV40...

Beim Axialstechen ins Volle ist die komplette Stechtiefe nur im Durchmesserbereich bis 50mm erreichbar.

When face grooving into solid the overall groove depth can only be obtained in diameter range up to 50mm.

Con la scanalatura assiale dal pieno la profondità completa di scanalatura si ottiene solamente per una gamma di diametri fino a 50mm.

Hinweis: Auf diese Halter passen alle Schneideinsätze von den Seiten 397 bis 398.

Remark: The inserts for these holders you will find on pages 397 to 398.

Nota: Inserti per questi adattatori a pagg da 397 a 398.

Ersatzteile / Spare Parts / Ricambi

Trägerwerkzeug Holder Utensile	Gewindestift Threaded pin Spina filettata
HSAV 2006	2 x DIN913-M5x10
HSAV 2008 - 2510	2 x DIN913-M6x8



ARNO®

WERKZEUGE

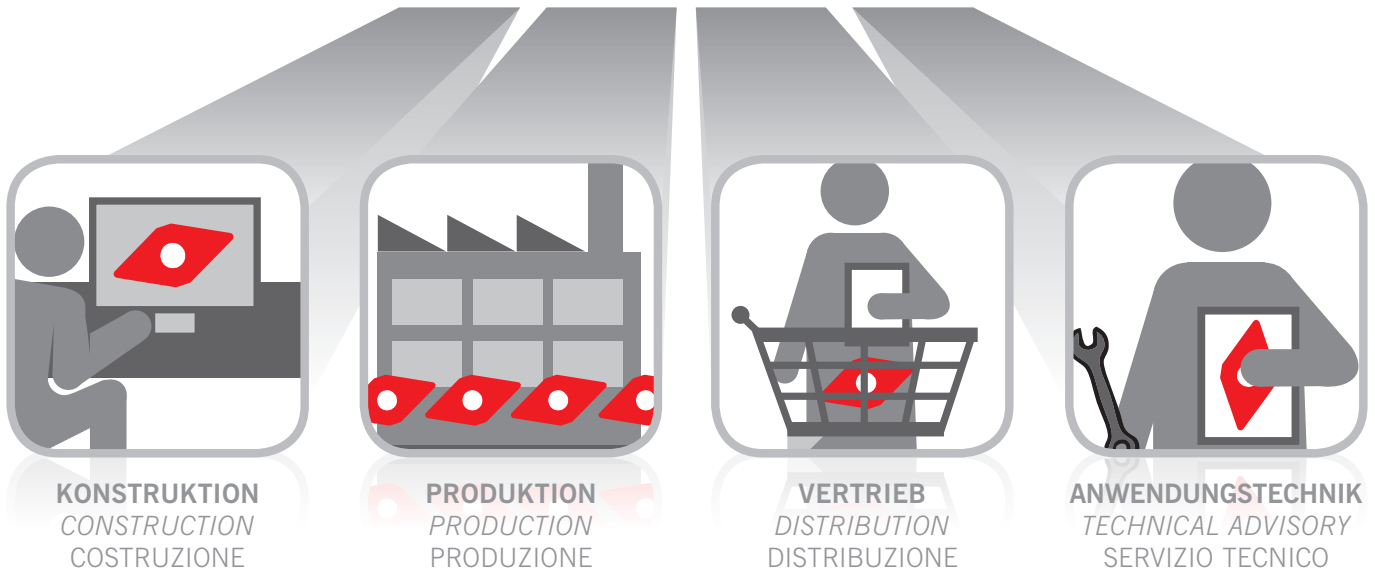

Schnell, flexibel und individuell.

Quick, flexible and individual.

Veloce, flessibile e individuale.

Konstruktion, Produktion und Vertrieb unter einem Dach.

Das ist die perfekte Verbindung um Ihnen Standard- und Sonderprodukte schnell und hochwertig anbieten zu können.

95% der Standardprodukte sind sofort verfügbar: Bei Bestellung bis 18 Uhr erhalten Sie Ihre Produkte bereits am nächsten Tag.

Mit großer fachlicher Kompetenz betreut Sie unser Außendienst-Team, unsere Anwendungstechniker helfen Ihnen mit Spezial-Wissen gerne auch vor Ort.

To have design, production and service all under one roof

is the perfect way of providing standard and special products.

95% of the standard programme is available from stock. Order received before 18.00 CET are dispatched the very same day and in most cases supplied next day.

Our competent team of technical sales engineers will be available to support you on site.

Costruzione, Produzione e Distribuzione sotto un unico tetto.

La sequenza perfetta per garantire un servizio di supporto cliente su prodotti Standard e Speciali di alta qualità.

Il 95% dei prodotti Standard sono disponibili a stock; con ordini entro le 18:00 garantiamo la consegna il giorno successivo.

Il nostro team di vendita altamente qualificato si offre come supporto alla produzione presso i nostri clienti direttamente sul territorio.

Weitere Informationen finden Sie unter:

For more information see:

Altre informazioni su:

www.arno.de

AMS – Beschichtet / Coated / Rivestito**PVD-Mehrlagenbeschichtung**

PVD beschichtetes Hartmetallsubstrat mit hoher Hitze- und Oxidationsbeständigkeit. Universelle Sorten zur Bearbeitung von Stählen, rostfreien Stählen und Gusswerkstoffen.

PVD-multilayer coating

PVD coated carbide substrate with high heat and oxidation resistance. Universal grade for machining steel, stainless steel and cast materials.

Rivestimento multiplo PVD

Tutti gli inserti sono previsti in una unica qualità di metallo duro universale molto resistente alle alte temperature con rivestimento PVD. Grado universale per la lavorazione di acciai, acciai inossidabile e fusioni oltre a materiali non ferrosi.

AMS – AH7525 – Unbeschichtet / Uncoated / Non rivestito**Universelle CBN-Sorte**

für glatten sowie unterbrochenem Schnitt. Die zähe Sorte ist geeignet für die Bearbeitung von gehärteten Stählen (48 – 65 HRC)

Universal CBN grade

for both smooth and interrupted cutting. The tough grade is well suited for machining hardened steel (48 – 65 HRC).

Grado universale CBN

per taglio continuo ed interrotto. La sua durezza è adatta per la lavorazione di acciai temprati (48 – 65 HRC).

SAV – Beschichtet / Coated / Rivestito**AL40****PVD-Mehrlagenbeschichtung**

Hochwarmfeste Beschichtung zur Bearbeitung von Stählen, austenitischen Stählen, sämtlichen Gusswerkstoffen, warmfesten Legierungen und Titanlegierungen.

PVD multilayer coating

High temperature resistant coating for machining steel, austenetic steel, all cast steels, high temperature alloys and titanium alloys.

Rivestimento PVD multistrato

Rivestimento per la lavorazione di acciai, acciai austenitici, ghisa, leghe di titanio e leghe refrattarie.

SAV – Unbeschichtet / Uncoated / Non rivestito**AK40**

Unbeschichtete Feinstkorn-Hartmetallsorte mit guter Kantenstabilität und hoher Zuverlässigkeit zur Bearbeitung von Stahl, sämtlichen Gusswerkstoffen und NE-Metallen.

Micrograin carbide grade with strong edge stability and high toughness for machining steel, all cast steels and non-ferrous materials.

Metallo duro a grana fine con elevata stabilità e tenacità per la lavorazione di acciaio, ghisa e metalli non ferrosi.

Drehen / Turning / Inserti di tornitura

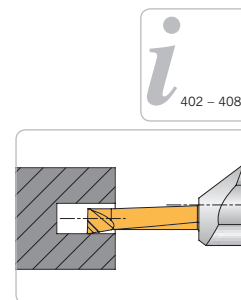
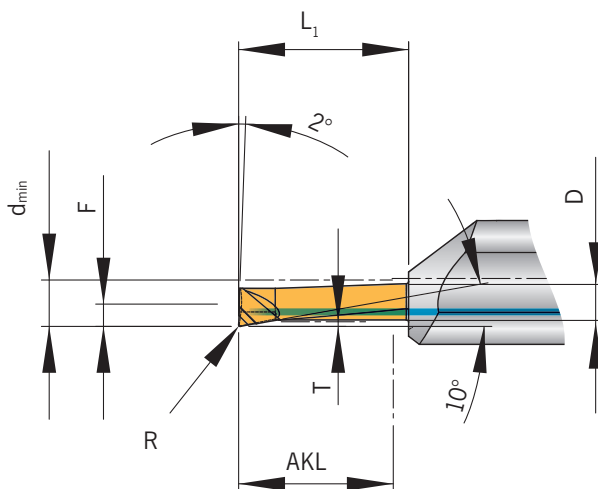

T = Nutztiefe [mm]
R = Radius [mm]
F = F-Maß [mm]
D = Durchmesser des Inserts
T = Depth [mm]
R = Radius [mm]
F = F-Dimension [mm]
D = Diameter of the insert
T = Profondità massima di lavoro [mm]
R = Raggio di punta [mm]
F = Dimensione F [mm]
D = Diametro dell'inserto

NEU/NEW/NUOVO

PG 44

beschichtet
coated
rivestito

Bezeichnung Designation Articolo	d _{min}	AKL	T	R	F	L ₁	D	
AMS-D-07005005-020.40R	0,7	2	0,05	0,05	0,30	4	4	●
AMS-D-20015002-060.40R	2,0	6	0,15	0,02	0,90	8	4	●
AMS-D-20015002-100.40R	2,0	10	0,15	0,02	0,90	12	4	●
AMS-D-220401-060.40R	2,2	6	0,40	0,10	1,05	8	4	●
AMS-D-250401-100.40R	2,5	10	0,40	0,10	1,15	12	4	●
AMS-D-250401-150.40R	2,5	15	0,40	0,10	1,15	17	4	●
AMS-D-250401-200.40R	2,5	20	0,40	0,10	1,15	22	4	●
AMS-D-300401-100.40R	3,0	10	0,40	0,10	1,40	12	4	●
AMS-D-300401-150.40R	3,0	15	0,40	0,10	1,40	17	4	●
AMS-D-300401-200.40R	3,0	20	0,40	0,10	1,40	22	4	●
AMS-D-300402-100.40R	3,0	10	0,40	0,20	1,40	12	4	●
AMS-D-300402-150.40R	3,0	15	0,40	0,20	1,40	17	4	●
AMS-D-300402-200.40R	3,0	20	0,40	0,20	1,40	22	4	●
AMS-D-390602-100.40R	3,9	10	0,60	0,20	1,90	12	4	●
AMS-D-390602-150.40L/R	3,9	15	0,60	0,20	1,90	17	4	●
AMS-D-390602-200.40L/R	3,9	20	0,60	0,20	1,90	22	4	●
AMS-D-40015005-250.40L/R	4,0	25	0,15	0,05	1,90	27	4	●
AMS-D-400301-250.40R	4,0	25	0,30	0,10	1,90	27	4	●
AMS-D-590801-150.60R	5,9	15	0,80	0,10	2,90	17	6	●
AMS-D-590802-100.60R	5,9	10	0,80	0,20	2,90	12	6	●
AMS-D-590802-200.60L/R	5,9	20	0,80	0,20	2,90	22	6	●
AMS-D-590802-300.60L/R	5,9	30	0,80	0,20	2,90	32	6	●
AMS-D-590804-200.60R	5,9	20	0,80	0,40	2,90	22	6	●
AMS-D-6005015-420.60R	6,0	42	0,50	0,15	2,90	44	6	●
AMS-D-791002-100.80R	7,9	10	1,00	0,20	3,90	12	8	●
AMS-D-791002-250.80L/R	7,9	25	1,00	0,20	3,90	27	8	●
AMS-D-820402-300.80R	8,2	30	0,40	0,20	3,90	32	8	●
AMS-D-1021002-200.100R	10,2	20	1,00	0,20	4,90	22	10	●
AMS-D-1021002-300.100R	10,2	30	1,00	0,20	4,90	32	10	●

P	●
M	●
K	●
N	●
S	●
H	

● Hauptanwendung
Main application
Applicazione principale
○ Nebenanwendung
Secondary application
Applicazione secondaria

7

Drehen / Turning / Inserti di tornitura

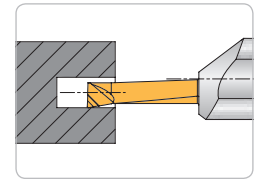
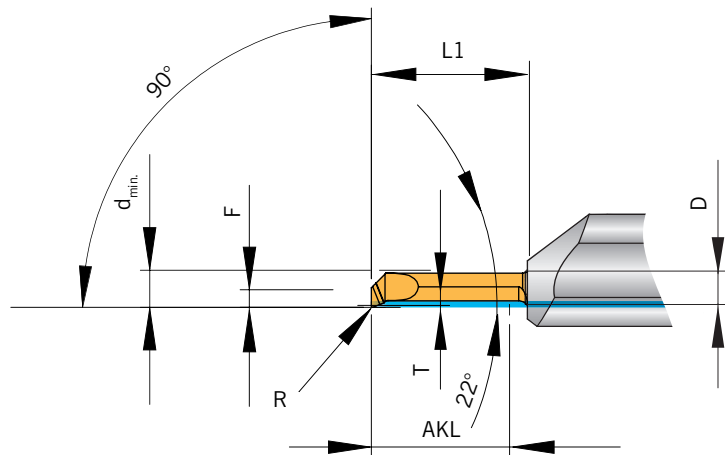

T = Nutztiefe [mm]
R = Radius [mm]
F = F-Maß [mm]
D = Durchmesser des Einsatzes
T = Depth [mm]
R = Radius [mm]
F = F-Dimension [mm]
D = Diameter of the insert
T = Profondità massima di lavoro [mm]
R = Raggio di punta [mm]
F = Dimensione F [mm]
D = Diametro dell'inserto

								PG 44
								beschichtet coated rivestito
Bezeichnung Designation Articolo	d _{min}	AKL	T	R	F	L ₁	D	
AMS-D20-3001502-150.40R	3	15	0,15	0,2	1,3	17	4	●
AMS-D20-400302-150.40R	4	15	0,30	0,2	1,9	17	4	●
AMS-D20-500502-100.60R	5	10	0,50	0,2	2,3	12	6	●
AMS-D20-500502-150.60R	5	15	0,50	0,2	2,3	17	6	●

P	●
M	●
K	●
N	●
S	●
H	

● Hauptanwendung
Main application
Applicazione principale
○ Nebenanwendung
Secondary application
Applicazione secondaria

Stechen / Grooving / Scanalatura

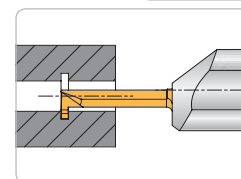
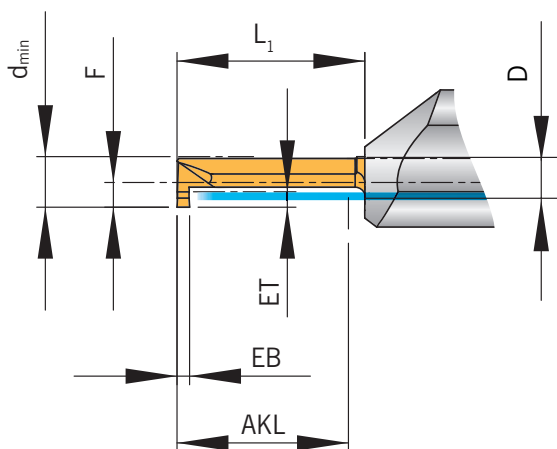

EB = Einstehtiefe [mm]
 ET = Einstehtiefe [mm]
 F = F-Maß [mm]
 D = Durchmesser des Einsatzes
 EB = Groove width [mm]
 ET = Groove depth [mm]
 F = F-Dimension [mm]
 D = Diameter of the insert
 EB = Larghezza gola [mm]
 ET = Profondità gola [mm]
 F = Dimensione F [mm]
 D = Diametro dell'inserto

N NEU/NEW/
NUOVO

PG 44

beschichtet
coated
rivestito

Bezeichnung Designation Articolo	d _{min}	AKL	EB + 0,03	ET	F	L ₁	D	
AMS-S-25080600-100.40R	2,5	10	0,8	0,6	1,15	12	4	●
AMS-S-25080600-150.40R	2,5	15	0,8	0,6	1,15	17	4	●
AMS-S-25080600-200.40R	2,5	20	0,8	0,6	1,15	22	4	●
AMS-S-30080600-100.40R	3,0	10	0,8	0,6	1,40	12	4	●
AMS-S-30080600-150.40R	3,0	15	0,8	0,6	1,40	17	4	●
AMS-S-30080600-200.40R	3,0	20	0,8	0,6	1,40	22	4	●
AMS-S-39081004-100.40R N	3,9	10	0,8	1,0	1,90	12	4	●
AMS-S-39100800-100.40R	3,9	10	1,0	0,8	1,90	12	4	●
AMS-S-39100800-150.40L/R	3,9	15	1,0	0,8	1,90	17	4	●
AMS-S-39100800-200.40R	3,9	20	1,0	0,8	1,90	22	4	●
AMS-S-59101800-200.60L/R	5,9	20	1,0	1,8	2,90	22	6	●
AMS-S-59151800-100.60R	5,9	10	1,5	1,8	2,90	12	6	●
AMS-S-59151800-200.60L/R	5,9	20	1,5	1,8	2,90	22	6	●
AMS-S-59151800-300.60R	5,9	30	1,5	1,8	2,90	32	6	●
AMS-S-69202500-150.80L/R	6,9	15	2,0	2,5	3,90	17	8	●
AMS-S-79182500-100.80R	7,9	10	1,8	2,5	3,90	12	8	●
AMS-S-79182500-250.80R	7,9	25	1,8	2,5	3,90	27	8	●

P	●
M	●
K	●
N	●
S	●
H	

● Hauptanwendung
Main application
Applicazione principale

○ Nebenanwendung
Secondary application
Applicazione secondaria

7

Radius-Einstich / Radius grooving / Profilo a raggio pieno

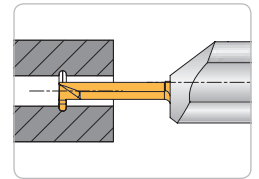
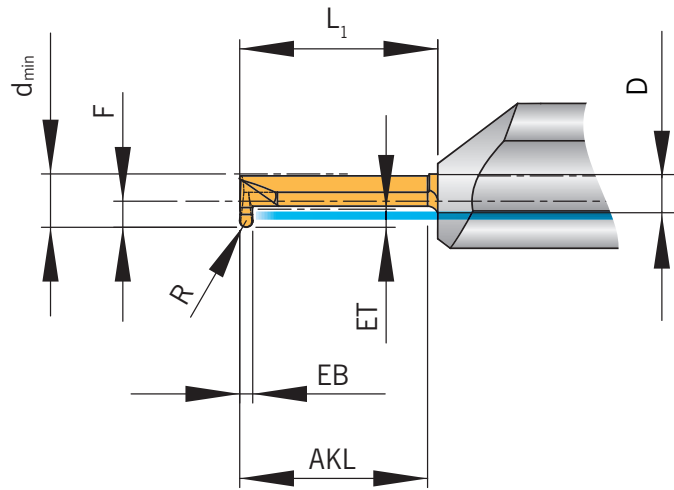

EB = Einstechbreite [mm]
ET = Einstechtiefe [mm]
R = Radius [mm]
F = F-Maß [mm]
D = Durchmesser des Einsatzes
EB = Grooving width [mm]
ET = Grooving depth [mm]
R = Radius [mm]
F = F-Dimension [mm]
D = Diameter of the insert
EB = Larghezza gola [mm]
ET = Profondità gola [mm]
R = Raggio di punta [mm]
F = Dimensione F [mm]
D = Diametro dell'inserto

PG 44

beschichtet
coated
rivestito

Bezeichnung Designation Articolo	d_{min}	AKL	EB + 0,03	ET	R	F	L_1	D	
AMS-S-39100805-100.40R	3,9	10	1,0	0,8	0,50	1,9	12	4	●
AMS-S-39100805-150.40L/R	3,9	15	1,0	0,8	0,50	1,9	17	4	●
AMS-S-39100805-200.40R	3,9	20	1,0	0,8	0,50	1,9	22	4	●
AMS-S-59151875-100.60R	5,9	10	1,5	1,8	0,75	2,9	12	6	●
AMS-S-59151875-200.60R	5,9	20	1,5	1,8	0,75	2,9	22	6	●
AMS-S-59151875-300.60R	5,9	30	1,5	1,8	0,75	2,9	32	6	●
AMS-S-82202010-200.80R	8,2	20	2,0	2,0	1,00	3,9	22	8	●

P	●
M	●
K	●
N	●
S	●
H	

● **Hauptanwendung**
Main application
 Applicazione principale
 ○ **Nebenanwendung**
Secondary application
 Applicazione secondaria



Seegering DIN 471/472 / Cir-clip grooving DIN 471/472 / Sedi Seeger DIN 471/472

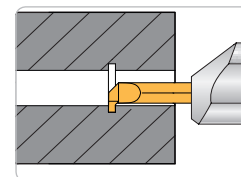
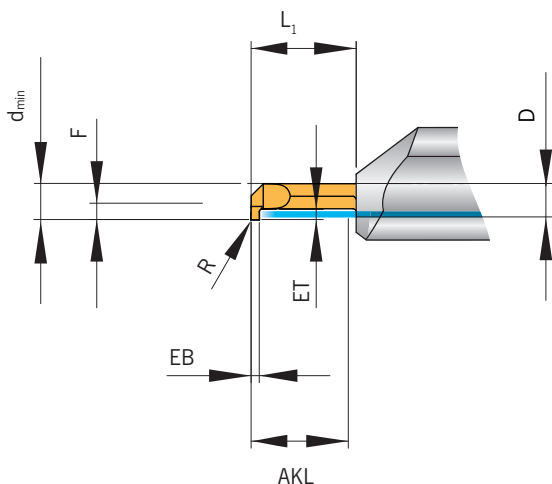

ET = Einstechtiefe (mm)
R = Radius (mm)
F = F-Maß (mm)
D = Durchmesser des Einsatzes
ET = Groove depth [mm]
R = Radius [mm]
F = F-Dimension [mm]
D = Diameter of the insert
ET = Profondità gola [mm]
R = Raggio di punta [mm]
F = Dimensione F [mm]
D = Diametro dell'inserto

PG 44

beschichtet
coated
rivestito

Bezeichnung Designation Articolo	d _{min}	AKL	EB ± 0,025	ET	R	F	L ₁	D	
AMS-472-41099110-150.40R	4,1	15	0,99	1,1	0,05	1,9	17	4	●
AMS-472-41119110-150.40R	4,1	15	1,19	1,1	0,05	1,9	17	4	●
AMS-472-41139110-150.40R	4,1	15	1,39	1,1	0,05	1,9	17	4	●
AMS-472-41169110-150.40R	4,1	15	1,69	1,1	0,05	1,9	17	4	●
AMS-472-61099150-150.60R	6,1	15	0,99	1,5	0,05	2,9	17	6	●
AMS-472-61119150-150.60R	6,1	15	1,19	1,5	0,05	2,9	17	6	●
AMS-472-61139150-150.60R	6,1	15	1,39	1,5	0,05	2,9	17	6	●
AMS-472-61169150-150.60R	6,1	15	1,69	1,5	0,05	2,9	17	6	●
AMS-472-61194150-150.60R	6,1	15	1,94	1,5	0,05	2,9	17	6	●
AMS-472-84119200-200.80R	8,4	20	1,19	2,0	0,05	3,9	22	8	●
AMS-472-84139200-200.80R	8,4	20	1,39	2,0	0,05	3,9	22	8	●
AMS-472-84169250-200.80R	8,4	20	1,69	2,5	0,05	3,9	22	8	●
AMS-472-84194250-200.80R	8,4	20	1,94	2,5	0,05	3,9	22	8	●
AMS-472-84224300-200.80R	8,4	20	2,24	3,0	0,05	3,9	22	8	●
AMS-472-84274350-200.80R	8,4	20	2,74	3,5	0,05	3,9	22	8	●
AMS-472-84328350-200.80R	8,4	20	3,28	3,5	0,05	3,9	22	8	●
AMS-472-104139350-250.100R	10,4	25	1,39	3,5	0,05	4,9	27	10	●
AMS-472-104169350-250.100R	10,4	25	1,69	3,5	0,05	4,9	27	10	●
AMS-472-104194350-250.100R	10,4	25	1,94	3,5	0,05	4,9	27	10	●
AMS-472-104224350-250.100R	10,4	25	2,24	3,5	0,05	4,9	27	10	●
AMS-472-104274350-250.100R	10,4	25	2,74	3,5	0,05	4,9	27	10	●
AMS-472-104328350-250.100R	10,4	25	3,28	3,5	0,05	4,9	27	10	●

P	●
M	●
K	●
N	●
S	●
H	

● Hauptanwendung
Main application
Applicazione principale
○ Nebenanwendung
Secondary application
Applicazione secondaria

7



**Sonderlösungen –
genau auf Sie zugeschnitten.**

*Special solutions especially
for your application!*

Soluzioni speciali –
su misura per voi.

**Sie haben eine Aufgabe –
wir haben die Lösung.**

Nutzen Sie unsere langjährige Erfahrung im Bereich der Sonderwerkzeuge und arbeiten Sie mit ARNO-Werkzeugen in Zukunft effektiver und kostengünstiger.

Ganz egal ob Sonderschneideinsätze oder komplexe Kombi-Werkzeuge – wir fertigen Ihnen flexibel, schnell und präzise nahezu jeden Wunsch.

*You have an application –
we have a solution.*

Take advantage of our many years' experience in special solutions and in future benefit from more efficient and cost effective ARNO tooling.

Whether it is special inserts or complex combination tools – we are able to offer nearly any solutions.

**Hai un problema –
chiedici la nostra soluzione.**

La nostra pluriennale esperienza nell'ambito delle lavorazioni meccaniche ci rende capaci di offrire qualsiasi soluzione di lavorazione nell'ambito delle nostre competenze specifiche.

Sia per singoli inserti o utensili e sia per complete combinazioni di utensili.

Un servizio veloce, flessibile e preciso per ogni esigenza.

Weitere Informationen finden Sie unter:

For more information see:

Altre informazioni su:

www.arno.de

Kopieren / Copying / Copiatura

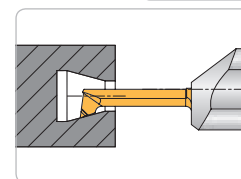
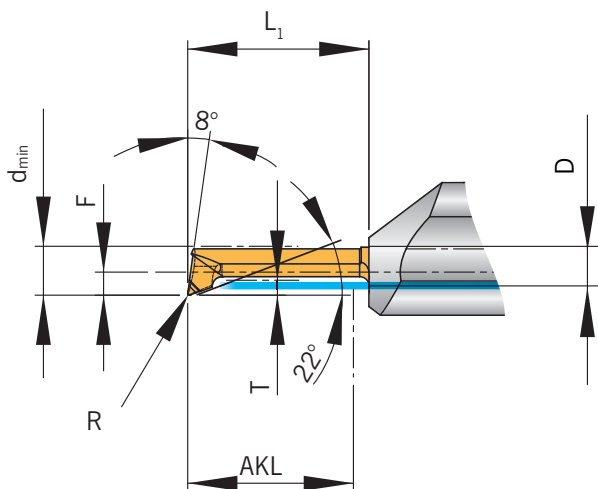

T = Nutztiefe [mm]
R = Radius [mm]
F = F-Maß [mm]
D = Durchmesser des Einsatzes
T = Depth [mm]
R = Radius [mm]
F = F-Dimension [mm]
D = Diameter of the insert
T = Profondità massima di lavoro [mm]
R = Raggio di punta [mm]
F = Dimensione F [mm]
D = Diametro dell'inserto

PG 44

beschichtet
coated
rivestito

Bezeichnung Designation Articolo	d _{min}	AKL	T	R	F	L ₁	D	
AMS-K-1501005-110.40R	1,5	11	0,10	0,05	1,30	12	4	●
AMS-K-1501501-060.40R	1,5	6	0,15	0,10	1,30	7	4	●
AMS-K-20015005-100.40L/R	2,0	10	0,10	0,05	0,90	11	4	●
AMS-K-2003005-060.40R	2,0	6	0,30	0,05	0,90	7	4	●
AMS-K-2003005-100.40R	2,0	10	0,30	0,05	0,90	11	4	●
AMS-K-220201-150.40R	2,2	15	0,20	0,10	0,95	16	4	●
AMS-K-250401-100.40R	2,5	10	0,40	0,10	1,15	12	4	●
AMS-K-250401-150.40R	2,5	15	0,40	0,10	1,15	17	4	●
AMS-K-250401-200.40R	2,5	20	0,40	0,10	1,15	22	4	●
AMS-K-300401-100.40R	3,0	10	0,40	0,10	1,40	12	4	●
AMS-K-300401-150.40R	3,0	15	0,40	0,10	1,40	17	4	●
AMS-K-300401-200.40L/R	3,0	20	0,40	0,10	1,40	22	4	●
AMS-K-390802-100.40R	3,9	10	0,80	0,20	1,90	12	4	●
AMS-K-390802-150.40L/R	3,9	15	0,80	0,20	1,90	17	4	●
AMS-K-390802-200.40L/R	3,9	20	0,80	0,20	1,90	22	4	●
AMS-K-391304-200.40R	3,9	20	1,30	0,40	1,90	22	4	●
AMS-K-400602-200.40R	4,0	20	0,60	0,20	1,90	22	4	●
AMS-K-400604-120.40R	4,0	12	0,60	0,40	1,90	14	4	●
AMS-K-400604-150.40R	4,0	15	0,60	0,40	1,90	17	4	●
AMS-K-500502-100.60L/R	5,0	10	0,50	0,20	2,30	12	6	●
AMS-K-500502-150.60R	5,0	15	0,50	0,20	2,30	17	6	●
AMS-K-500502-200.60R	5,0	20	0,50	0,20	2,30	22	6	●
AMS-K-500502-250.60L/R	5,0	25	0,50	0,20	2,30	26	6	●
AMS-K-500502-300.60R	5,0	30	0,50	0,20	2,30	31	6	●
AMS-K-590502-350.60R	5,9	35	0,50	0,20	2,90	37	6	●
AMS-K-590502-400.60R	5,9	40	0,50	0,20	2,90	42	6	●
AMS-K-590502-500.60R	5,9	50	0,50	0,20	2,90	52	6	●
AMS-K-591802-100.60R	5,9	10	1,80	0,20	2,90	12	6	●
AMS-K-591802-200.60R	5,9	20	1,80	0,20	2,90	22	6	●
AMS-K-591802-300.60L/R	5,9	30	1,80	0,20	2,90	32	6	●
AMS-K-6005015-420.60R	6,0	42	0,50	0,15	2,30	44	6	●
AMS-K-720502-450.80R	7,2	45	0,50	0,20	3,45	47	8	●
AMS-K-800502-500.80R	8,0	50	0,50	0,20	3,90	52	8	●
AMS-K-893902-200.80R	8,9	20	3,90	0,20	3,90	22	8	●
AMS-K-893902-300.80R	8,9	30	3,90	0,20	3,90	32	8	●

7

Kopieren / Copying / Copiatura

								PG 44
								beschichtet <i>coated</i> rivestito
Bezeichnung <i>Designation</i> Articolo	d _{min}	AKL	T	R	F	L ₁	D	
AMS-K-1084902-250.100R	10,8	25	4,90	0,20	4,90	27	10	●
AMS-K-1084902-350.100R	10,8	35	4,90	0,20	4,90	37	10	●

P	●
M	●
K	●
N	●
S	●
H	

- **Hauptanwendung**
Main application
Applicazione principale
- **Nebenanwendung**
Secondary application
Applicazione secondaria



Kopieren - verstärkte Ausführung / Copying – reinforced version / Copiatura - versione rinforzata

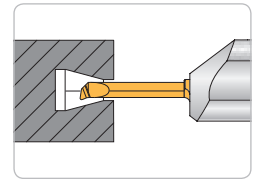
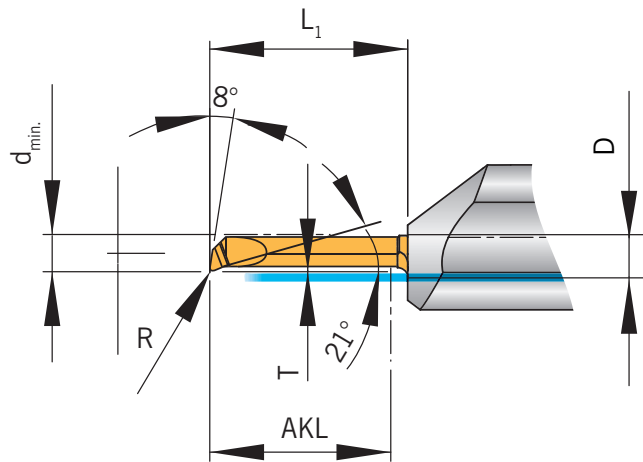

T = Nutztiefe [mm]
R = Radius [mm]
F = F-Maß [mm]
D = Durchmesser des Einsatzes
T = Depth [mm]
R = Radius [mm]
F = F-Dimension [mm]
D = Diameter of the insert
T = Profondità massima di lavoro [mm]
R = Raggio di punta [mm]
F = Dimensione F [mm]
D = Diametro dell'inserto

PG 44

beschichtet
coated
rivestito

Bezeichnung
Designation
Articolo

	d_{min}	AKL	T	R	F	L_1	D	
AMS-K-300202-100.40L/R	3,0	10	0,2	0,20	1,30	12	4	●
AMS-K-300202-150.40R	3,0	15	0,2	0,20	1,30	17	4	●
AMS-K-3202015-100.40R	3,2	10	0,2	0,15	1,45	12	4	●
AMS-K-400301-250.40R	4,0	25	0,3	0,10	1,50	27	4	●
AMS-K-400302-100.40L/R	4,0	10	0,3	0,20	1,90	12	4	●

P	●
M	●
K	●
N	●
S	●
H	

● Hauptanwendung
Main application
Applicazione principale

○ Nebenanwendung
Secondary application
Applicazione secondaria

Inserts
Inserti

Kopieren - versetzte und verstärkte Ausführung / Copying - offset and reinforced version / Copiatura - versione disassata e rinforzata

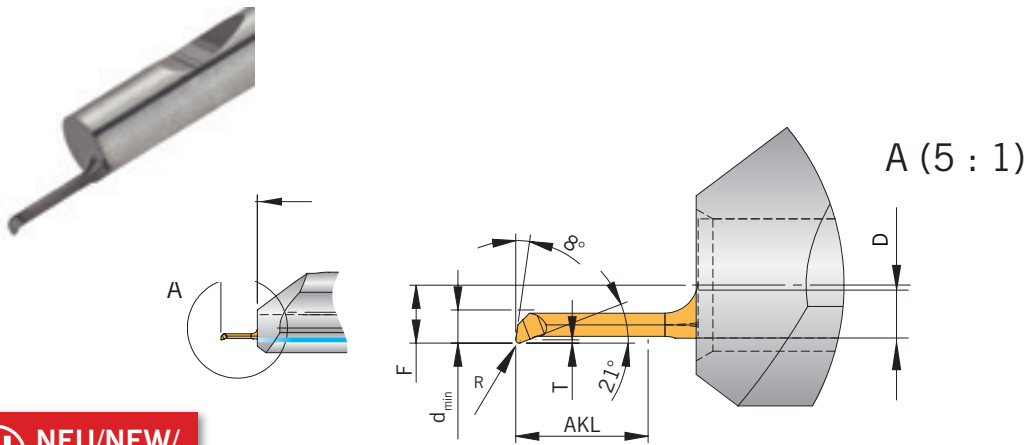
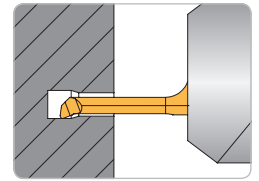

T = Nutztiefe [mm]
R = Radius [mm]
F = F-Maß [mm]
D = Durchmesser des Einsatzes
T = Depth [mm]
R = Radius [mm]
F = F-Dimension [mm]
D = Diameter of the insert
T = Profondità massima di lavoro [mm]
R = Raggio di punta [mm]
F = Dimensione F [mm]
D = Diametro dell'inserto

N NEU/NEW/NUOVO

								PG 44
								beschichtet coated rivestito
Bezeichnung Designation Articolo	d _{min}	AKL	T	R	F	L ₁	D	
AMS-K-100101-040.40R N	1	4	0,1	0,1	1,75	5,5	4	●

P	●
M	●
K	●
N	●
S	●
H	

● **Hauptanwendung**
Main application
Applicazione principale

○ **Nebenanwendung**
Secondary application
Applicazione secondaria

7

Kopieren 45° / Copying 45° / Copiatura 45°

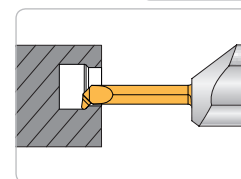
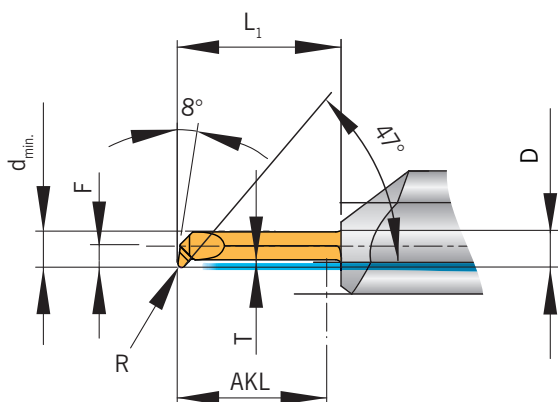

T = Nutztiefe [mm]
R = Radius [mm]
F = F-Maß [mm]
D = Durchmesser des Einsatzes
T = Depth [mm]
R = Radius [mm]
F = F-Dimension [mm]
D = Diameter of the insert
T = Profondità massima di lavoro [mm]
R = Raggio di punta [mm]
F = Dimensione F [mm]
D = Diametro dell'inserto

N NEU/NEW/
NUOVO

PG 44

beschichtet
coated
rivestito

Bezeichnung Designation Articolo	d _{min}	AKL	T	R	F	L ₁	D	
AMS-K45-3906015-200.40R	3,9	20	0,6	0,15	1,90	22	4	●
AMS-K45-391304-200.40R	3,9	20	1,3	0,40	1,90	22	4	●
AMS-K45-400604-120.40R	4,0	12	0,6	0,40	1,90	14	4	●
AMS-K45-400604-150.40R	4,0	15	0,6	0,40	1,90	17	4	●
AMS-K45-4008015-200.40R	4,0	20	0,8	0,15	1,90	22	4	●
AMS-K45-5010015-250.60R	5,0	25	1,0	0,15	2,45	27	6	●
AMS-K45-5918015-150.60L/R ^N	5,9	15	1,8	0,15	2,90	17	6	●
AMS-K45-5918015-300.60R	5,9	30	1,8	0,15	2,90	32	6	●
AMS-K45-692902-100.60R	6,9	10	2,9	0,20	2,90	12	6	●
AMS-K45-692902-150.60L/R ^N	6,9	15	2,9	0,20	2,90	17	6	●
AMS-K45-692902-200.60R	6,9	20	2,9	0,20	2,90	22	6	●
AMS-K45-692902-300.60R	6,9	30	2,9	0,20	2,90	32	6	●
AMS-K45-893902-150.80R	8,9	15	3,9	0,20	3,90	17	8	●
AMS-K45-893902-200.80R	8,9	20	3,9	0,20	3,90	22	8	●
AMS-K45-893902-300.80R	8,9	30	3,9	0,20	3,90	32	8	●

P	●
M	●
K	●
N	●
S	●
H	

● **Hauptanwendung**
Main application
 Applicazione principale
 ○ **Nebenanwendung**
Secondary application
 Applicazione secondaria

Inserts
Inserti

Kopieren - CBN bestückt / Copy turning - CBN brazed / Copiatura - riporto CBN

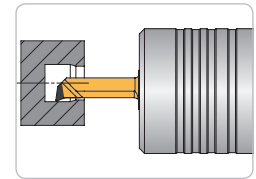

- T = Nutztiefe [mm]
- R = Radius [mm]
- F = F-Maß [mm]
- D = Durchmesser des Inserts
- T = Depth [mm]
- R = Radius [mm]
- F = F-Dimension [mm]
- D = Diameter of the insert
- T = Profondità massima di lavoro [mm]
- R = Raggio di punta [mm]
- F = Dimensione F [mm]
- D = Diametro dell'inserto

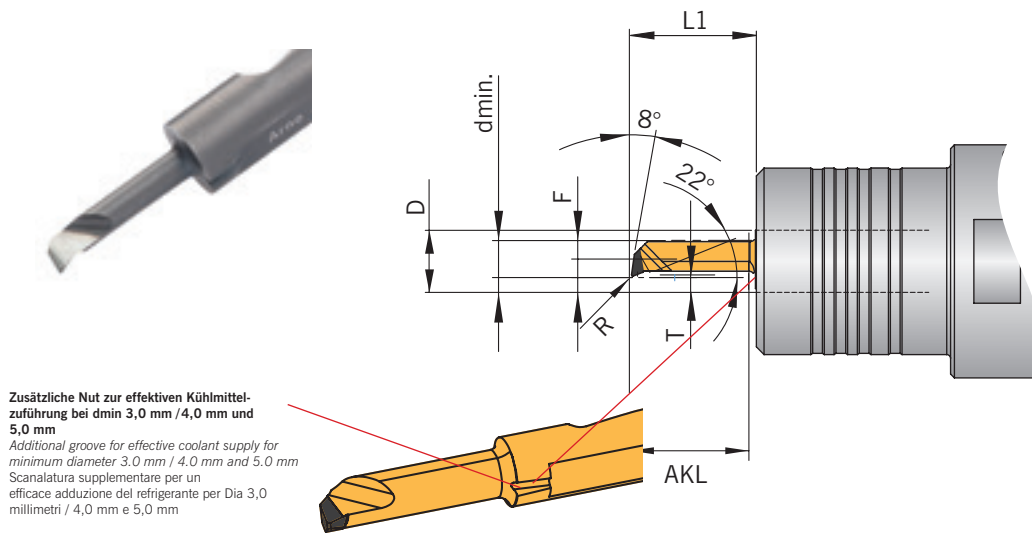

Zusätzliche Nut zur effektiven Kühlmittel-zuführung bei dmin 3,0 mm / 4,0 mm und 5,0 mm
Additional groove for effective coolant supply for minimum diameter 3.0 mm / 4.0 mm and 5.0 mm
Scanalatura supplementare per un efficace adduzione del refrigerante per Dia 3,0 millimetri / 4,0 mm e 5,0 mm

								PG 44
								bestückt brazed riporto
Bezeichnung Designation Articolo	d _{min}	AKL	T	R	F	L ₁	D	AH7525
AMS-K-300201-100.60R	3	10	0,2	0,1	1,5	12	6	●
AMS-K-400302-130.60R	4	13	0,3	0,2	2,0	15	6	●
AMS-K-500402-150.60R	5	15	0,4	0,2	2,5	17	6	●
AMS-K-600402-180.60R	6	18	0,4	0,2	3,0	20	6	●

P	
M	
K	
N	
S	
H	●

- Hauptanwendung
Main application
Applicazione principale
- Nebenanwendung
Secondary application
Applicazione secondaria



Inserts
Inserti

Vorstechen und Fasen / Pre-grooving and chamfering / Pre-scantatura e smusso

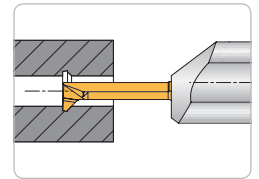
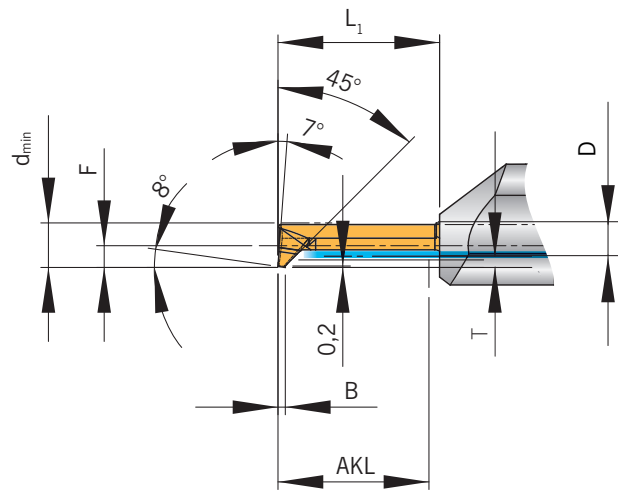

B = Breite (mm)
T = Nutztiefe (mm)
F = F-Maß (mm)
D = Durchmesser des Einsatzes
B = Width (mm)
T = Depth (mm)
F = F-Dimension (mm)
D = Diameter of the insert
B = Larghezza (mm)
T = Profondità massima di lavoro (mm)
F = Dimensione F (mm)
D = Diametro dell'inserto

PG 44

beschichtet
coated
rivestito

Bezeichnung Designation Articolo	d_{min}	AKL	T	B + 0,03	F	L_1	D	
AMS-V-50100800-200.60R	5,0	20	0,8	1	2,4	22	6	●
AMS-V-59100800-200.60R	5,9	20	0,8	1	2,9	22	6	●

P	●
M	●
K	●
N	●
S	●
H	

● **Hauptanwendung**
Main application
 Applicazione principale
 ○ **Nebenanwendung**
Secondary application
 Applicazione secondaria

7

Zentrum Fasen 45° / 60° / Centre Chamfering 45° / 60° / Smussatura centrale 45° / 60°

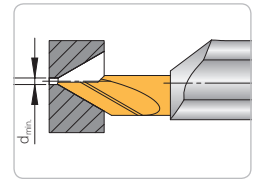

SB = Schnittbreite [mm]
W = Winkel [Grad]
F = F-Maß [mm]
D = Durchmesser des Einsatzes
SB = Cutting width [mm]
W = Angle [degree]
F = F-Dimension [mm]
D = Diameter of the insert
SB = Larghezza di taglio [mm]
W = Angolo [grad]
F = Dimensione F [mm]
D = Diametro dell'inserto

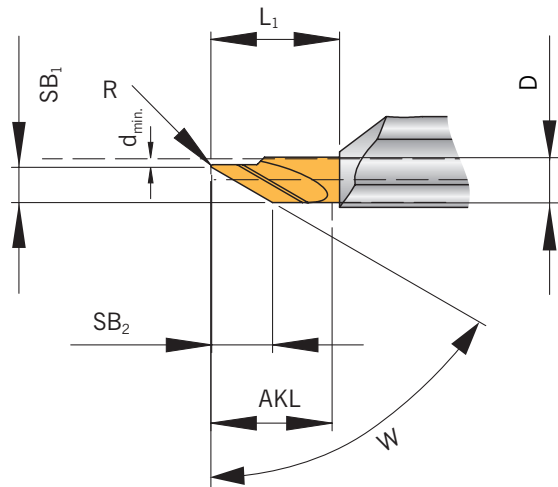

											PG 44
											beschichtet coated rivestito
Bezeichnung Designation Articolo	d_{min}	SB_1	SB_2	W	AKL	R	F	L_1	D		
AMS-ZF45-104502-150.60L/R	1	4,5	4,5	45°	15	0,2	2	17	6	●	
AMS-ZF60-108002-150.60L/R	1	4,5	7,9	60°	15	0,2	2	17	6	●	

P	●
M	●
K	●
N	●
S	●
H	

● **Hauptanwendung**
Main application
 Applicazione principale
 ○ **Nebenanwendung**
Secondary application
 Applicazione secondaria



Fasen 45° / Chamfering 45° / Smusso 45°

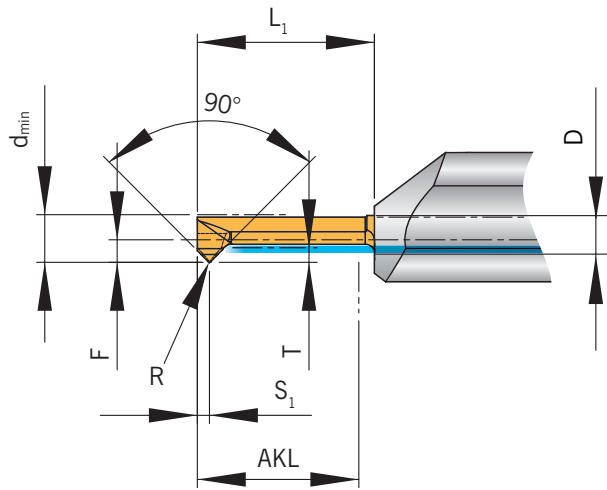
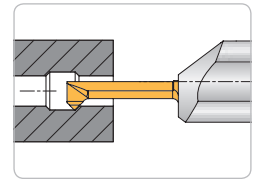

T = Nutztiefe [mm]
R = Radius
S1 = S-Maß [mm]
F = F-Maß [mm]
D = Durchmesser des Einsatzes
T = Depth [mm]
R = Radius [mm]
S1 = S-Dimension [mm]
F = F-Dimension [mm]
D = Diameter of the insert
T = Profondità massima di lavoro [mm]
R = Raggio di punta [mm]
S1 = Dimensione S [mm]
F = Dimensione F [mm]
D = Diametro dell'inserto

PG 44

beschichtet
coated
rivestito

Bezeichnung Designation Articolo	d _{min}	AKL	T	S ₁	R	F	L ₁	D	
AMS-F-250401-150.40R	2,5	15	0,4	1,0	0,1	1,15	17	4	●
AMS-F-300401-150.40R	3,0	15	0,4	1,0	0,1	1,40	17	4	●
AMS-F-390802-150.40R	3,9	15	0,8	1,2	0,2	1,90	17	4	●
AMS-F-591802-200.60R	5,9	20	1,8	2,0	0,2	2,90	22	6	●

P	●
M	●
K	●
N	●
S	●
H	

● **Hauptanwendung**
Main application
 Applicazione principale
 ○ **Nebenanwendung**
Secondary application
 Applicazione secondaria

Rückwärtsdrehen / Back turning / Lavorazione in tirata

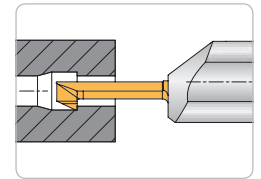
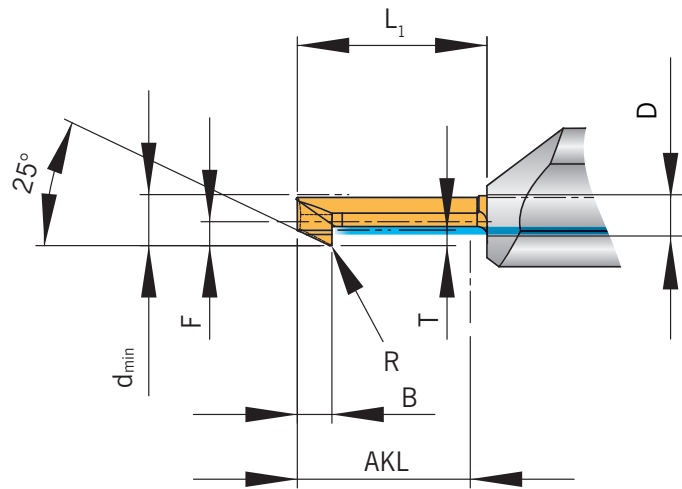

- B = Breite [mm]
- T = Nutztiefe [mm]
- R = Radius [mm]
- F = F-Maß [mm]
- D = Durchmesser des Einsatzes
- B = Width [mm]
- T = Depth [mm]
- R = Radius [mm]
- F = F-Dimension [mm]
- D = Diameter of the insert
- B = Larghezza [mm]
- T = Profondità massima di lavoro [mm]
- R = Raggio di punta [mm]
- F = Dimensione F [mm]
- D = Diametro dell'inserto

PG 44

beschichtet
coated
rivestito

Bezeichnung Designation Articolo	d _{min}	AKL	T	B	R	F	L ₁	D	
AMS-R-39401002-150.40R	3,9	15	1	4	0,2	1,9	17	4	●
AMS-R-59402002-200.60R	5,9	20	2	4	0,2	2,9	22	6	●

P	●
M	●
K	●
N	●
S	●
H	

- Hauptanwendung
Main application
Applicazione principale
- Nebenanwendung
Secondary application
Applicazione secondaria



Inserts
Inserti

Gewinde 60° - Metrisch-Teilprofil Threading 60° - Metric partial profile Filettatura 60° - Metrica profilo parziale

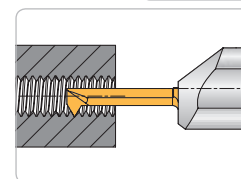
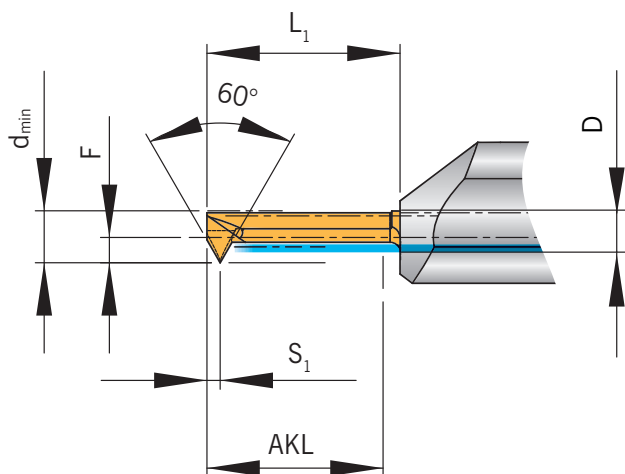

S1 = S-Maß [mm]
F = F-Maß [mm]
D = Durchmesser des Einsatzes
S1 = S-Dimension [mm]
F = F-Dimension [mm]
D = Diameter of the insert
S1 = Dimensione S [mm]
F = Dimensione F [mm]
D = Diametro dell'inserto

PG 44

beschichtet
coated
rivestito

Bezeichnung Designation Articolo	d _{min}	AKL	Gewinde Threading Filettatura	P Steigung P Pitch P Passo	S ₁	F	L ₁	D	
AMS-G-MF020050-050.40R	2,3	5	>M2,5	0,2 - 0,5	0,45	1,1	6,5	4	●
AMS-G-MF050070-150.40R	3,0	15	M4	0,5 - 0,7	0,70	1,4	17,0	4	●
AMS-G-MF050100-150.40R	4,0	15	M5	0,5 - 1,0	0,70	1,9	17,0	4	●
AMS-G-MF050150-200.60R	6,0	20	M8	0,5 - 1,5	0,80	2,9	22,0	6	●

MF = ISO-Innengewinde Metrisch Fein
MF - ISO-Metric - Fine
MF - Filettatura Metrica ISO - Passo Fine

P	●
M	●
K	●
N	●
S	●
H	

● Hauptanwendung
Main application
Applicazione principale
○ Nebenanwendung
Secondary application
Applicazione secondaria

Gewinde 60° - Metrisch-Vollprofil Threading 60° - Metric full profile Filettatura 60° - Metrica profilo completo

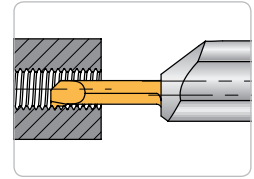

S1 = S-Maß [mm]
F = F-Maß [mm]
D = Durchmesser des Inserts
S1 = S-Dimension [mm]
F = F-Dimension [mm]
D = Diameter of the insert
S1 = Dimensione S [mm]
F = Dimensione F [mm]
D = Diametro dell'inserto

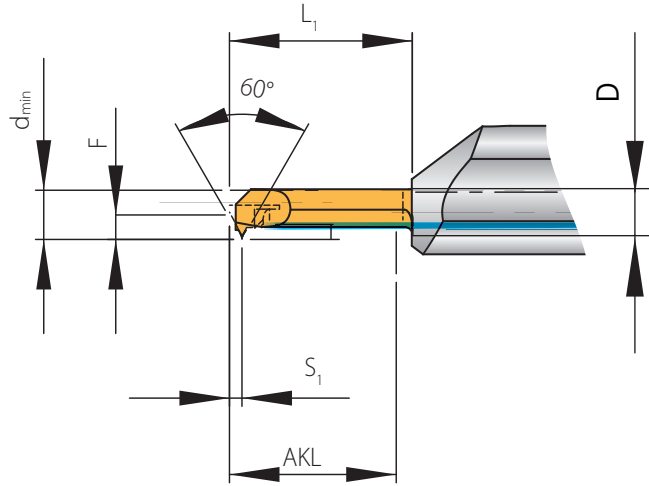

N NEU/NEW/
NUOVO

PG 44

beschichtet
coated
rivestito

Bezeichnung Designation Articolo	d _{min}	AKL	Gewinde Threading Filettatura	P Steigung P Pitch P Passo	S ₁	F	L ₁	D	
AMS-GV-MF025-150.40R N	3,7	16	M4,5	0,25	0,4	1,9	18	4	●
AMS-GV-MF035-150.40R N	3,7	16	M4,5	0,35	0,4	1,9	18	4	●
AMS-GV-MF050-150.40R	4,0	15	MF	0,50	0,4	1,9	17	4	●
AMS-GV-MF060-150.40R	4,0	15	MF	0,60	0,4	1,9	17	4	●
AMS-GV-MF070-150.40R	4,1	15	MF	0,70	0,5	1,9	17	4	●
AMS-GV-MF075-150.40R	4,2	15	MF	0,75	0,5	1,9	17	4	●
AMS-GV-M100-200.60R	4,8	20	M6	1,00	0,7	2,9	22	6	●
AMS-GV-M100-150.40R	5,0	15	M6	1,00	0,7	1,9	17	4	●
AMS-GV-MF025-150.60R N	5,1	16	M4	0,25	0,4	2,5	18	6	●
AMS-GV-MF080-150.60R N	5,3	16	M6	0,80	0,5	2,6	18	6	●
AMS-GV-MF050-150.60R	5,4	15	MF	0,50	0,4	2,5	17	6	●
AMS-GV-MF075-150.60R	5,6	15	MF	0,75	0,5	2,6	17	6	●
AMS-GV-M100-150.60R	5,7	15	M10	1,00	0,7	2,6	17	6	●
AMS-GV-M125-200.60R	6,0	20	M8	1,25	0,8	2,9	22	6	●
AMS-GV-M150-200.60R	6,0	20	M12	1,50	1,0	2,9	22	6	●

M = ISO-Innengewinde Metrisch
M = ISO-Metric
M = Filettatura Metrica ISO
MF = ISO-Innengewinde Metrisch Fein
MF = ISO-Metric - Fine
MF = Filettatura Metrica ISO - Passo Fine

P	●
M	●
K	●
N	●
S	●
H	

● Hauptanwendung
Main application
Applicazione principale

○ Nebenanwendung
Secondary application
Applicazione secondaria

Whitworth Gewinde 55° - Teilprofil Whitworth thread 55° - Partial profile Filettatura Whitworth 55° - Profilo parziale

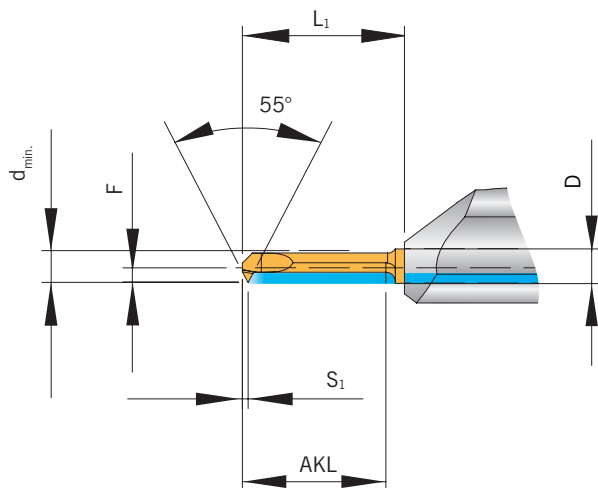
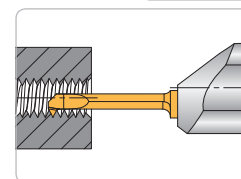

S1 = S-Maß [mm]
F = F-Maß [mm]
D = Durchmesser des Einsatzes
 S1 = S-Dimension [mm]
 F = F-Dimension [mm]
 D = Diameter of the insert
 S1 = Dimensione S [mm]
 F = Dimensione F [mm]
 D = Diametro dell'inserto

PG 44

beschichtet
coated
rivestito

Bezeichnung Designation Articolo	d _{min}	AKL	Gewinde Threading Filettatura	P Steigung P Pitch P Passo	S ₁	F	L ₁	D	
AMS-G-WF33025100-150.40R	3,3	15	WF	0,25 - 1,0	0,6	1,5	17	4	●
AMS-G-WF43025100-150.40R	4,3	15	WF	0,25 - 1,0	0,6	1,9	17	4	●
AMS-G-WF60050150-150.60R	6,0	15	WF	0,5 - 1,5	0,8	2,9	17	6	●

WF = Whitworth - Feingewinde
 WF = Whitworth - Fine
 WF = Filettatura Whitworth - Passo fine

P	●
M	●
K	●
N	●
S	●
H	

● **Hauptanwendung**
 Main application
 Applicazione principale
 ○ **Nebenanwendung**
 Secondary application
 Applicazione secondaria

Whitworth Rohrgewinde 55° - DIN ISO 228-Vollprofil
 Whitworth pipe thread 55° - DIN ISO 228-Full profil
 Filettatura Whitworth 55° - DIN ISO 228-Profilo completo

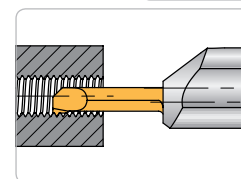

S1 = S-Maß (mm)
 F = F-Maß (mm)
 D = Durchmesser des Einsatzes
 S1 = S-Dimension (mm)
 F = F-Dimension (mm)
 D = Diameter of the insert
 S1 = Dimensione S (mm)
 F = Dimensione F (mm)
 D = Diametro dell'inserto

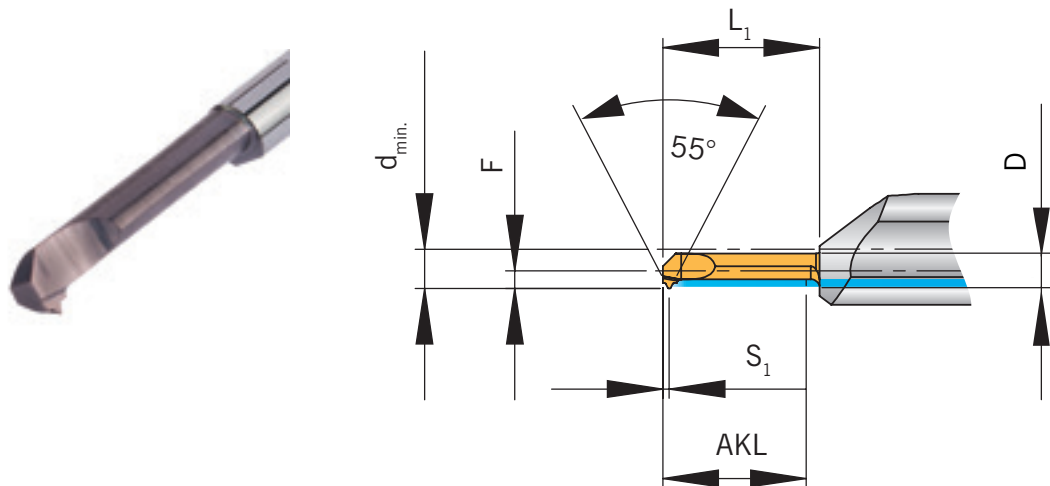

										PG 44
										beschichtet coated rivestito
Bezeichnung Designation Articolo	d _{min}	AKL	Gewinde Threading Filettatura	P Steigung P Pitch P Passo	G/Inch TPI G/Inch	S ₁	F	L ₁	D	
AMS-GV-W228/20-150.40R	4	15	W228	1,27	20	0,70	1,9	17	4	●
AMS-GV-W228/19-150.60R	11	15	1/4"-19 BSP	1,33	19	0,95	2,9	17	6	●

P	●
M	●
K	●
N	●
S	●
H	

● **Hauptanwendung**
Main application
Applicazione principale

○ **Nebenanwendung**
Secondary application
Applicazione secondaria



Whitworth Rohrgewinde 55° BSW-Vollprofil Whitworth pipe thread 55° BSW-Full profil Filettatura Whitworth 55° BSW-Profilo completo

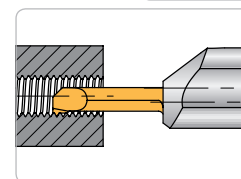

S₁ = S-Maß [mm]
F = F-Maß [mm]
D = Durchmesser des Einsatzes
S₁ = S-Dimension [mm]
F = F-Dimension [mm]
D = Diameter of the insert
S₁ = Dimensione S [mm]
F = Dimensione F [mm]
D = Diametro dell'inserto

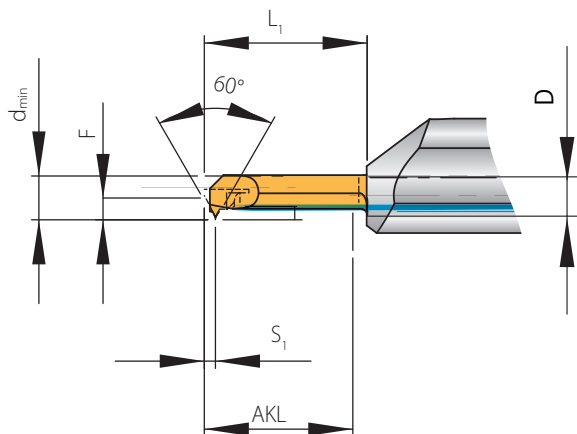

PG 44

beschichtet
coated
rivestito

Bezeichnung Designation Articolo	d _{min}	AKL	Gewinde Threading Filettatura	G/Inch TPI G/Inch	S ₁	F	L ₁	D	
AMS-GV-BSW24-150.40R	3,4	15	3/16"-24BSW	24	0,75	1,3	17	4	●
AMS-GV-BSW24-150.60R	3,4	15	3/16"-24BSW	24	0,75	0,3	17	6	●
AMS-GV-BSW28-150.60R	4,4	15	7/32"-28BSW	28	0,65	1,2	17	6	●
AMS-GV-BSW22-150.60R	6,5	15	5/16"-22BSW	22	0,90	2,9	17	6	●

P	●
M	●
K	●
N	●
S	●
H	

● **Hauptanwendung**
 Main application
 Applicazione principale
 ○ **Nebenanwendung**
 Secondary application
 Applicazione secondaria

Trapezgewinde 30° DIN-ISO 103 – Teilprofil

Trapezoidal 30° DIN ISO 103 – Partial profile

Filettatura Trapezoidale 30° DIN ISO 103 – Profilo parziale

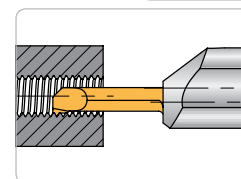
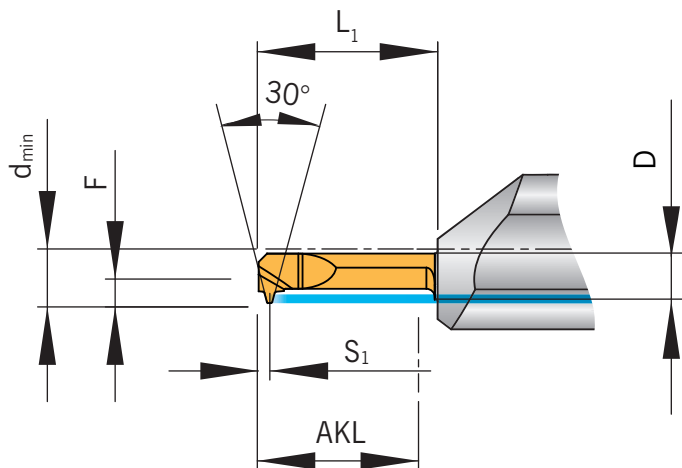

S1 = S-Maß [mm]
 F = F-Maß [mm]
 D = Durchmesser des Einsatzes
 S1 = S-Dimension [mm]
 F = F-Dimension [mm]
 D = Diameter of the insert
 S1 = Dimensione S [mm]
 F = Dimensione F [mm]
 D = Diametro dell'inserto

PG 44

beschichtet
coated
rivestito

Bezeichnung Designation Articolo	d _{min}	AKL	Gewinde Threading Filettatura	P Steigung P Pitch P Passo	S ₁	F	L ₁	D	
AMS-G-TR103/1.5R-200.60R	6,5	20	TR 8x1.5	1,5	0,85	2,9	22	6	●
AMS-G-TR103/2.0R-200.60R	7,0	20	TR 9x2.0	2,0	1,30	2,9	22	6	●
AMS-G-TR103/2.0R-200.80R	7,0	20	TR 9x2.0	2,0	1,30	2,6	22	8	●
AMS-G-TR103/3.0R-200.80R	8,0	20	TR 11x3.0	3,0	1,40	3,6	22	8	●

P	●
M	●
K	●
N	●
S	●
H	

● Hauptanwendung
Main application
Applicazione principale
○ Nebenanwendung
Secondary application
Applicazione secondaria



Inserts
Inserti

Amerikanische ISO-Zollgewinde 60° - UN - Vollprofil
American thread 60° - UN - Full profile
 Filettatura norme americane 60° - UN - Profilo completo

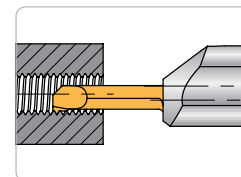

S1 = S-Maß (mm)
 F = F-Maß (mm)
 D = Durchmesser des Einsatzes
 S1 = S-Dimension (mm)
 F = F-Dimension (mm)
 D = Diameter of the insert
 S1 = Dimensione S (mm)
 F = Dimensione F (mm)
 D = Diametro dell'inserto

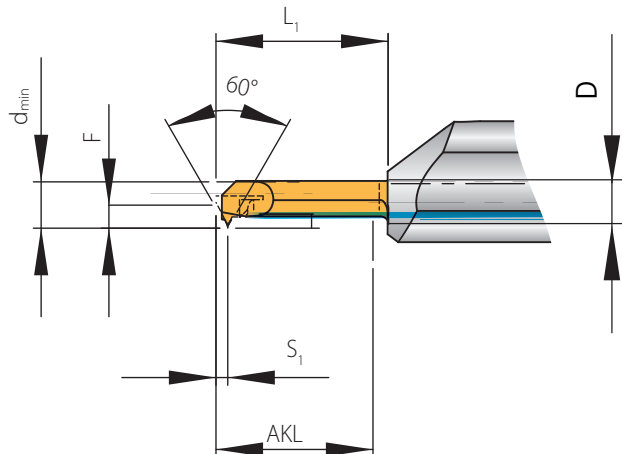

N NEU/NEW/
NUOVO

PG 44

beschichtet
coated
rivestito

Bezeichnung Designation Articolo	d _{min}	AKL	Gewinde Threading Filettatura	G/Inch TPI	S ₁	F	L ₁	D	
AMS-GV-UN32-110.40R N	2,35	12	No.6-32 UNC	32	0,60	0,45	17	4	●
AMS-GV-UN32-150.40R	2,60	16	No.6-32 UNC	32	0,60	0,45	17	4	●
AMS-GV-UN32-150.60R	2,60	16	No.6-32 UNC	32	0,60	-0,55	17	6	●
AMS-GV-UN24-150.40R	3,60	16	No.10-24 UNC	24	0,75	1,40	17	4	●
AMS-GV-UN24-150.60R	3,60	16	No.10-24 UNC	24	0,75	0,40	17	6	●
AMS-GV-UN28-150.40R	4,40	16	No.12-28 UNF	28	0,65	1,90	17	4	●
AMS-GV-UN20-150.60R	4,80	16	1/4"-20 UNC	20	0,90	1,50	17	6	●
AMS-GV-UN27-150.60R	5,30	16	1/4"-27 UNS	27	0,75	1,90	17	6	●
AMS-GV-UN18-150.60R	6,20	16	5/16"-18 UNC	18	1,00	2,90	17	6	●
AMS-GV-UN16-150.60R	7,60	16	3/8"-16 UNC	16	1,05	2,90	17	6	●

P	●
M	●
K	●
N	●
S	●
H	

● Hauptanwendung
Main application
Applicazione principale

○ Nebenanwendung
Secondary application
Applicazione secondaria

7

Axial Stechen / Axial grooving / Scanalatura assiale

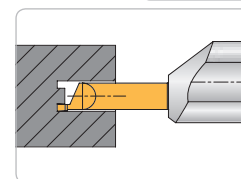
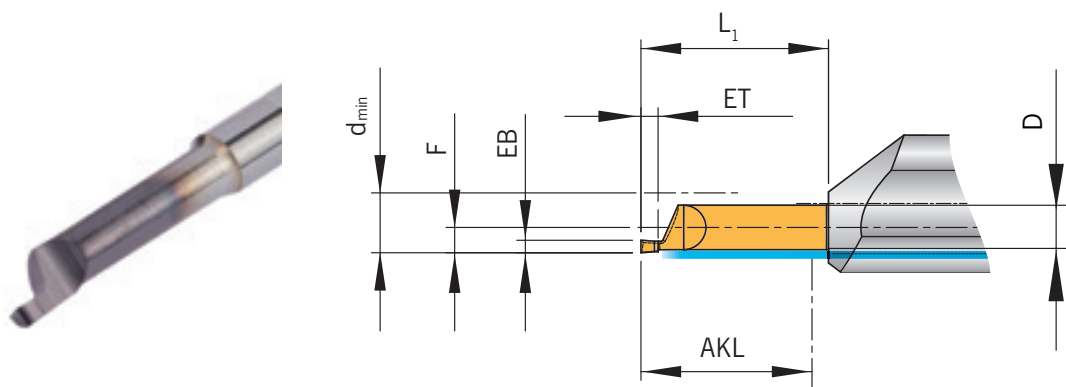

EB = Einstechbreite [mm]
ET = Einstechtiefe [mm]
R = Radius [mm]
F = F-Maß [mm]
D = Durchmesser des Einsatzes
EB = Grooving width [mm]
ET = Grooving depth [mm]
R = Radius [mm]
F = F-Dimension [mm]
D = Diameter of the insert
EB = Larghezza gola [mm]
ET = Profondità gola [mm]
R = Raggio di punta [mm]
F = Dimensione F [mm]
D = Diametro dell'inserto

PG 44

beschichtet
coated
rivestito

Bezeichnung Designation Articolo	d_{min}	AKL	EB + 0,03	ET	R	F	L_1	D	
AMS-A-50071100-075.40R	5	7,5	0,70	1,1	0,00	1,9	9,7	4	●
AMS-A-5007711005-075.40R	5	7,5	0,77	1,1	0,05	1,9	9,7	4	●
AMS-A-50081200-075.40R	5	7,5	0,80	1,2	0,00	1,9	9,7	4	●
AMS-A-50091300-075.40R	5	7,5	0,90	1,3	0,00	1,9	9,7	4	●
AMS-A-50101500-075.40R	5	7,5	1,00	1,5	0,00	1,9	10,0	4	●
AMS-A-50121500-075.40R	5	7,5	1,20	1,5	0,00	1,9	10,0	4	●
AMS-A-50121500-150.40R	5	15,0	1,20	1,5	0,00	1,9	17,0	4	●
AMS-A-502050005-100.40L/R	5	10,0	2,00	5,0	0,05	1,9	12,0	4	●
AMS-A-600971500-100.60R	6	10,0	0,97	1,5	0,00	2,4	12,0	6	●
AMS-A-60121500-100.60R	6	10,0	1,20	1,5	0,00	2,4	12,0	6	●
AMS-A-60121500-180.60R	6	18,0	1,20	1,5	0,00	2,4	20,0	6	●
AMS-A-70152000-100.60R	7	10,0	1,50	2,0	0,00	2,9	12,0	6	●
AMS-A-70152000-200.60R	7	20,0	1,50	2,0	0,00	2,9	22,0	6	●
AMS-A-801530015-100.80R	8	10,0	1,50	3,0	0,15	2,0	12,0	8	●
AMS-A-90152000-100.80R	9	10,0	1,50	2,0	0,00	3,8	12,0	8	●
AMS-A-90152000-250.80R	9	25,0	1,50	2,0	0,00	3,8	27,0	8	●

P	●
M	●
K	●
N	●
S	●
H	

● **Hauptanwendung**
Main application
 Applicazione principale
 ○ **Nebenanwendung**
Secondary application
 Applicazione secondaria



Halbzeuge zur Eigenprofilierung / Blanks for special profiles / Semilavorato per la realizzazione di speciali

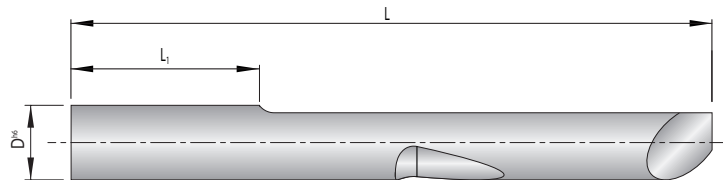

D = ϕ Profilleite [mm]
L1 = Auskraglänge [mm]
 Linke Ausführung abgebildet.
D = ϕ Profile side [mm]
L1 = Maximum work length [mm]
 Left hand execution shown
D = ϕ lato profilo [mm]
L1 = Massima lunghezza di lavoro [mm]
 Esecuzione sinistra in figura

N NEU/NEW/
NUOVO

PG 44

beschichtet
coated
rivestito

Bezeichnung Designation Articolo	D _{h6}	L	L ₁	
H-AMS-100-40L/R	4	34,4	10	●
H-AMS-150-40L/R	4	39,4	15	●
H-AMS-200-40L/R	4	44,4	20	●
H-AMS-250-40L/R	4	49,4	25	●
H-AMS-100-60L/R	6	40,6	10	●
H-AMS-150-60L/R	6	45,6	15	●
H-AMS-200-60L/R	6	50,6	20	●
H-AMS-250-60L/R	6	55,6	25	●
H-AMS-300-60L/R	6	60,6	30	●
H-AMS-350-60R	6	65,6	35	●
H-AMS-400-60R	6	70,6	40	●
H-AMS-450-60R	6	75,6	45	●
H-AMS-500-60R	6	80,6	50	●
H-AMS-100-80R	8	40,4	10	●
H-AMS-150-80L/R	8	45,4	15	●
H-AMS-200-80R	8	50,4	20	●
H-AMS-250-80L/R	8	55,4	25	●
H-AMS-300-80R	8	60,4	30	●
H-AMS-450-80R	8	75,4	45	●
H-AMS-500-80R	8	80,4	50	●
H-AMS-200-100R	10	50,4	20	●
H-AMS-250-100R	10	55,4	25	●
H-AMS-300-100R	10	60,4	30	●
H-AMS-350-100R	10	65,4	35	●

Hinweis: Sonderformen nach Kundenzeichnung auf Anfrage.
 Information: Special form inserts to customer's drawing on request.
 Indicazione: Esecuzione di profili speciali su richiesta.

P	●
M	●
K	●
N	●
S	●
H	

● Hauptanwendung
Main application
Applicazione principale

○ Nebenanwendung
Secondary application
Applicazione secondaria

Axial Stechen / Axial grooving / Scanalatura assiale

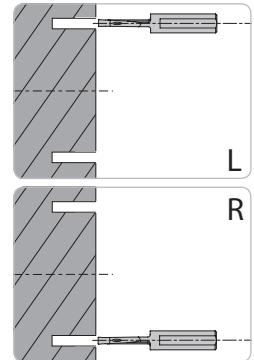
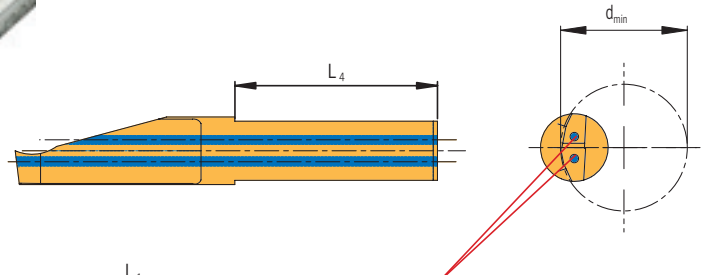

Linke Ausführung abgebildet
Left-hand execution shown
Esecuzione sinistra

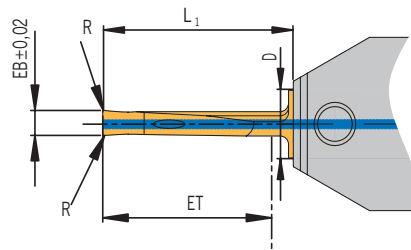

Innere Kühlmittelzuführung für garantiert optimale Kühlung an der Schneide und Prozesssicheren Spänetransport.
Through tool coolant for both maximum coolant direct at the cutting edge and swarf evacuation.
Il circuito di raffreddamento interno garantisce una refrigerazione ottimale sul tagliente insieme ad una buona evacuazione del truciolo.

EB = Einstehtiefe [mm]
ET = Einstechtiefe [mm]
R = Radius [mm]
D = Durchmesser des Einsatzes
EB = Grooving width [mm]
ET = Grooving depth [mm]
R = Radius [mm]
D = Diameter of the insert
EB = Larghezza gola [mm]
ET = Profondità gola [mm]
R = Raggio di punta [mm]
D = Diametro dell'inserto

Bezeichnung Designation Articolo	d _{min}	EB	ET	R	L ₁	L ₄	PG 19	
							beschichtet coated rivestito	unbeschichtet uncoated non rivestito
							AL40	AK40
SAV151006-IK-L/R	10	1,5	10	0,1	13	16	●	●
SAV151506-IK-L/R	10	1,5	15	0,1	18	16	●	●
SAV201206-IK-L/R	12	2,0	12	0,2	16	16	●	●
SAV202006-IK-L/R	12	2,0	20	0,2	23	16	●	●
SAV252008-IK-L/R	15	2,5	20	0,2	22	24	●	●
SAV302008-IK-L/R	15	3,0	20	0,2	22	24	●	●
SAV303008-IK-L/R	15	3,0	30	0,2	34	24	●	●
SAV403010-IK-L/R	30	4,0	30	0,2	34	24	●	●
SAV404010-IK-L/R	30	4,0	40	0,2	44	24	●	●

Beim Axialstechen ins Volle ist die komplette Stechtiefe nur im Durchmesserbereich bis 50mm erreichbar.
When face grooving into solid the overall groove depth can only be obtained in diameter range up to 50mm.
Con la scanalatura assiale dal pieno la profondità completa di scanalatura si ottiene solamente per una gamma di diametri fino a 50mm.
L₁ = Spannfläche
L₄ = Clamping flat
L₄ = Piano bloccaggio

	●	○
P	●	○
M	●	○
K	●	○
N	○	○
S	●	○
H	○	○

● Hauptanwendung
Main application
Applicazione principale
○ Nebenanwendung
Secondary application
Applicazione secondaria



Axial Stechen - Vollradiusausführung
 Axial grooving - Full radius execution
 Scanalatura assiale - Esecuzione a raggio completo

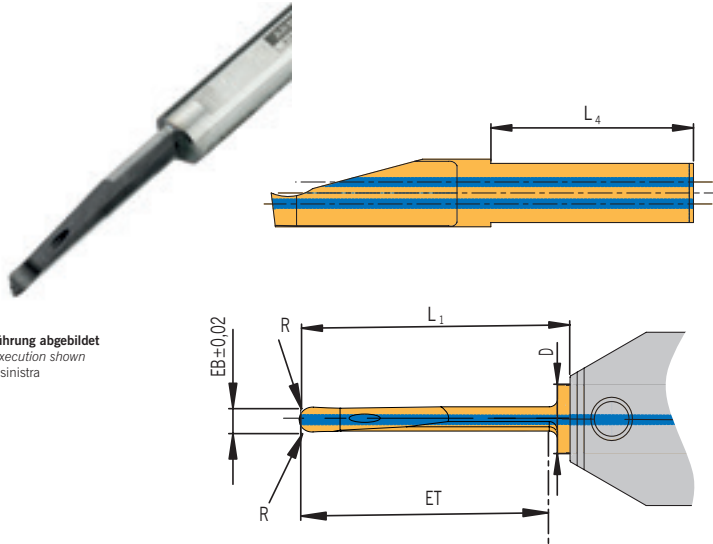
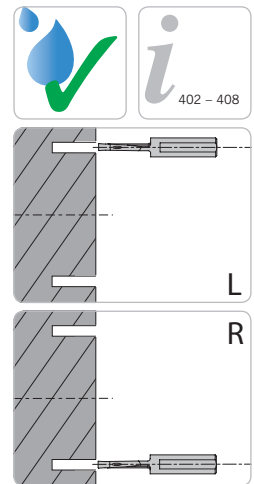

Linke Ausführung abgebildet
 Left-hand execution shown
 Esecuzione sinistra

Innere Kühlmittelzuführung für garantiert optimale Kühlung an der Schneide und Prozesssicheren Späneabtransport.
 Through tool coolant for both maximum coolant direct at the cutting edge and swarf evacuation. Il circuito di raffreddamento interno garantisce una refrigerazione ottimale sul tagliente insieme ad una buona evacuazione del truciolo.

EB = Einstechbreite [mm]
 ET = Einstechtiefe [mm]
 R = Radius [mm]
 D = Durchmesser des Einsatzes
 EB = Grooving width [mm]
 ET = Grooving depth [mm]
 R = Radius [mm]
 D = Diameter of the insert
 EB = Larghezza gola [mm]
 ET = Profondità gola [mm]
 R = Raggio di punta [mm]
 D = Diametro dell'inserto

							PG 19	
							beschichtet coated rivestito	unbeschichtet uncoated non rivestito
Bezeichnung Designation Articolo	d_{min}	EB	ET	R	L_1	L_4	AL40	AK40
SAV202006-V-IK-L/R	12	2	20	1,0	23	16	●	●
SAV303008-V-IK-L/R	15	3	30	1,5	34	24	●	●

Beim Axialstechen ins Volle ist die komplette Stechtiefe nur im Durchmesserbereich bis 50mm erreichbar.
 When face grooving into solid the overall groove depth can only be obtained in diameter range up to 50mm.
 Con la scanalatura assiale dal pieno la profondità completa di scanalatura si ottiene solamente per una gamma di diametri fino a 50mm.
V = Vollradiusausführung
 V = Full radius execution
 V = Esecuzione a raggio completo
L = Spannfläche
 L = Clamping flat
 L = Piano bloccaggio

P	●	●
M	●	●
K	●	●
N	●	●
S	●	
H		

● **Hauptanwendung**
 Main application
 Applicazione principale
 ○ **Nebenanwendung**
 Secondary application
 Applicazione secondaria



Sie brauchen eine Sonderausführung?

Wenn besondere Aufgaben individuelle Lösungen erfordern, sind Sie bei uns genau richtig.
Als Hersteller können wir AMS-Schneideinsätze schnell und zuverlässig nach Ihren Vorgaben fertigen.
Nennen Sie uns dazu einfach den Standard-Schneideinsatz und die Maße, die Sie gerne geändert hätten:

Standard-Schneideinsatz AMS- _____

Diese Maße bitte ändern: _____

Skizze:

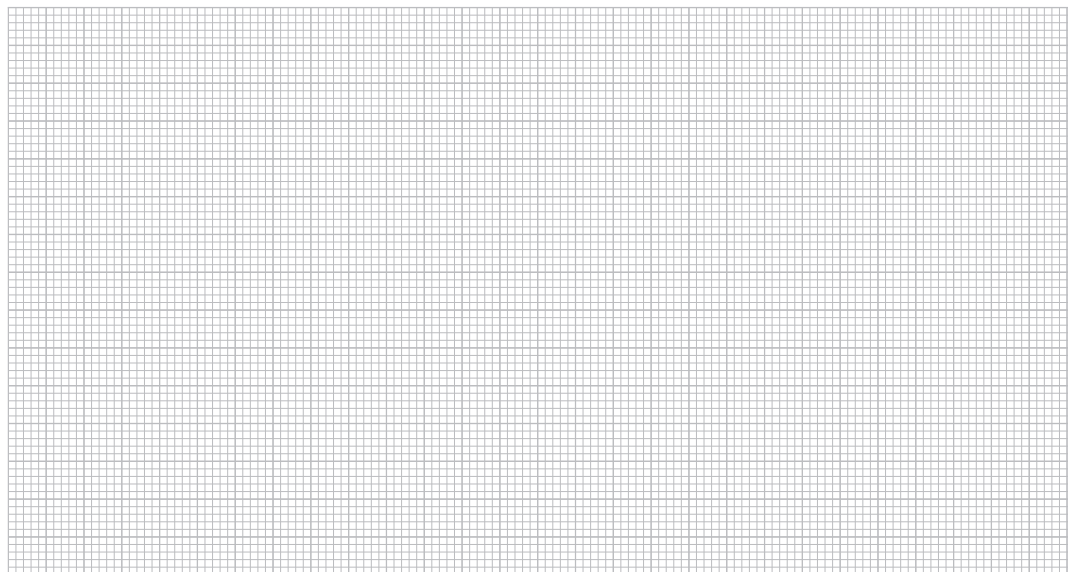

Adresse: Firma: _____

Anschrift: _____

Ansprechpartner: _____

E-Mail: _____

Telefon: _____

Auf www.arno.de/download gibt es diese Vorlage auch zum Herunterladen. Sie können uns auch gerne eine E-Mail mit den entsprechenden Angaben an anfrage@arno.de senden.



Do you need a special solution?

Should your application require a purpose made tool, we can quote that too.
As the manufacturer we can offer special AMS inserts, accurately and quickly.
Please tell us the standard inserts and the dimensions you would like to have changed:

Standard insert AMS- _____

Please change this dimensions: _____

Draft drawing:

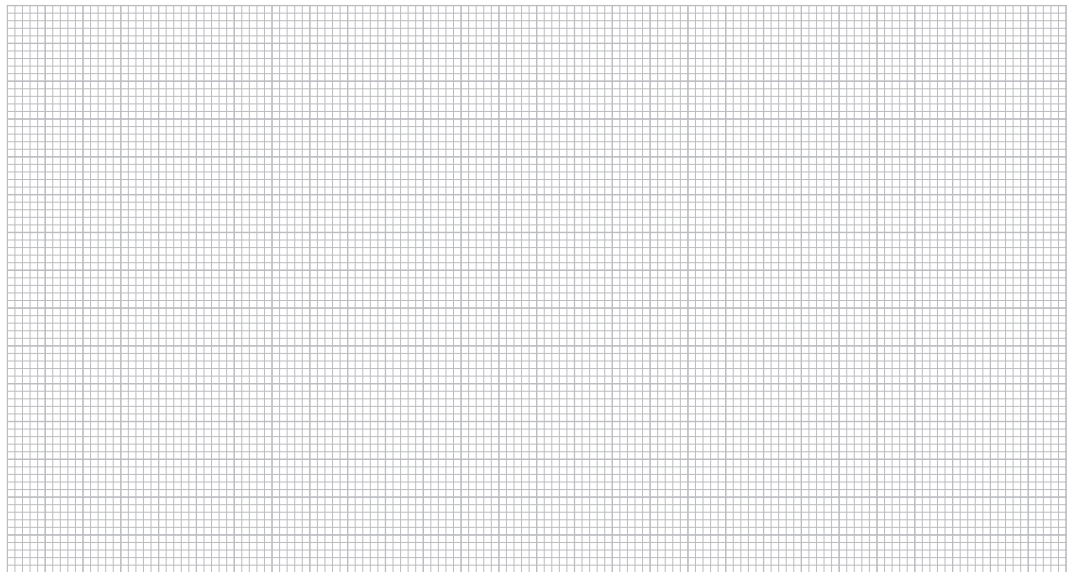

Address: _____ Company: _____

Address: _____

Contact: _____

E-Mail: _____

Phone: _____

**On www.arno.de/download you will find the form for downloading.
Or send an e-mail with the relevant information to anfrage@arno.de**



Serve una soluzione speciale?

Se vi dovesse servire una soluzione speciale non esitate a chiederci quotazione e studio.
Come produttori di questi utensili siamo in grado di darvi le migliori soluzioni per le vostre applicazioni.
Dateci tutte le misure richieste o le modifiche da apportare ad utensili standard:

Inserito standard AMS- _____

Dimensioni di riferimento _____

Disegno:

Indirizzo: Azienda: _____

Indirizzo: _____

Persona di contatto: _____

E-Mail: _____

Telefono: _____

**Su www.arno.de/service/downloads è possibile scaricare questo modulo di richiesta.
Oppure inviare via e-mail tutte le informazioni necessarie alla quotazione all'indirizzo
info@arno-italia.it**

Spare parts and accessories
Ricambi e accessori

Artikel / Item / Articolo	PG 11
Schraube / Screw / Vite	
AS 0043	●
AS 0044	●
Kühlmittelverschlussring / Coolant seal ring / Anello tenuta refrigerante	
KVR 12	●
KVR 16	●
KVR 20	●
Schlüssel / Key / Chiave	
KP 1111	●
KP 3111	●

Werkstoff- gruppe	Gliederung der Werkstoffhauptgruppen und Kennbuchstaben			Brinell-Härte	Zugfestigkeit (N/mm ²)	Zerspanungsgruppe	Schnittgeschwindigkeit V _c (m/min)	
							beschichtet	unbeschichtet
								AH7525
P	Unlegierter Stahl	C ≤ 0,25 %	geglüht	125	428	P1	20 - 100 - 180	-
		C > 0,25 ... ≤ 0,55 %	geglüht	190	639	P2	20 - 100 - 180	-
		C > 0,25 ... ≤ 0,55 %	vergütet	210	708	P3	20 - 100 - 180	-
		C > 0,55 %	geglüht	190	639	P4	20 - 100 - 180	-
		C > 0,55 %	vergütet	300	1013	P5	20 - 100 - 180	-
		Automatenstahl (kurzspanend)	geglüht	220	745	P6	20 - 100 - 180	-
	Niedrig legierter Stahl		geglüht	175	591	P7	15 - 90 - 160	-
			vergütet	300	1013	P8	15 - 90 - 160	-
			vergütet	380	1282	P9	15 - 90 - 160	-
			vergütet	430	1477	P10	15 - 90 - 160	-
	Hochlegierter Stahl und hochlegierter Werkzeugstahl		geglüht	200	675	P11	20 - 70 - 120	-
			gehärtet und angelassen	300	1013	P12	20 - 70 - 120	-
			gehärtet und angelassen	400	1361	P13	20 - 70 - 120	-
	Nichtrostender Stahl		ferritisch / martensitisch, geglüht	200	675	P14	20 - 55 - 90	-
		martensitisch, vergütet	330	1114	P15	20 - 100 - 180	-	
M	Nichtrostender Stahl		austenitisch, abgeschreckt	200	675	M1	20 - 55 - 90	-
			austenitisch, ausscheidungsgehärtet (PH)	300	1013	M2	15 - 50 - 80	-
			austenitisch-ferritisch, Duplex	230	778	M3	10 - 35 - 60	-
K	Temperguss		ferritisch	200	675	K1	20 - 70 - 120	-
			perritisch	260	867	K2	20 - 70 - 120	-
	Grauguss		niedrige Festigkeit	180	602	K3	20 - 80 - 140	-
			hohe Festigkeit / austenitisch	245	825	K4	20 - 80 - 140	-
	Gusseisen mit Kugelgraphit		ferritisch	155	518	K5	20 - 75 - 130	-
			perritisch	265	885	K6	20 - 75 - 130	-
		GGV (CGI)		200	675	K7	20 - 70 - 120	-
N	Aluminium-Knetlegierungen		nicht aushärtbar	30	-	N1	20 - 260 - 500	-
			aushärtbar, ausgehärtet	100	343	N2	20 - 260 - 500	-
			≤ 12 % Si, nicht aushärtbar	75	260	N3	20 - 260 - 500	-
	Aluminium-Gusslegierungen		≤ 12 % Si, aushärtbar, ausgehärtet	90	314	N4	20 - 260 - 500	-
			> 12 % Si, nicht aushärtbar	130	447	N5	20 - 260 - 500	-
		Magnesiumlegierungen		70	250	N6	-	-
	Kupfer und Kupferlegierungen (Bronze / Messing)		unlegiert, Elektrolytkupfer	100	343	N7	20 - 310 - 600	-
			Messing, Bronze, Rotguss	90	314	N8	20 - 310 - 600	-
			Cu-Legierung, kurzspanend	110	382	N9	20 - 310 - 600	-
			hochfest, Ampco	300	1013	N10	-	-
Nichtmetallische Werkstoffe		Thermoplaste (ohne abrasive Füllstoffe)	-	-	N11	-	-	
		Duroplaste (ohne abrasive Füllstoffe)	-	-	N12	-	-	
		Kunststoff glasfaserverstärkt GFRP	-	-	N13	-	-	
		Kunststoff kohlefaserverstärkt CFRP	-	-	N14	-	-	
		Kunststoff aramidfaserverstärkt AFRP	-	-	N15	-	-	
		Graphit (technisch)		80 Shore	-	N16	-	-
S	Warmfeste Legierungen	Fe-Basis	geglüht	200	675	S1	15 - 45 - 75	-
			ausgehärtet	280	943	S2	15 - 45 - 75	-
		Ni- oder Co-Basis	geglüht	250	839	S3	15 - 30 - 40	-
			ausgehärtet	350	1177	S4	15 - 30 - 40	-
			gegossen	320	1076	S5	15 - 30 - 40	-
	Titanlegierungen		Reintitan	200	675	S6	-	-
			α- und β-Legierungen, ausgehärtet	375	1262	S7	-	-
			β-Legierungen	410	1396	S8	-	-
		Wolframlegierungen		300	1013	S9	-	-
		Molybdänlegierungen		300	1013	S10	-	-
H	Gehärteter Stahl		gehärtet und angelassen	50 HRC	-	H1	-	60 - 105 - 150
			gehärtet und angelassen	55 HRC	-	H2	-	60 - 105 - 150
			gehärtet und angelassen	60 HRC	-	H3	-	60 - 105 - 150
		Gehärtetes Gusseisen	gehärtet und angelassen	55 HRC	-	H4	-	60 - 105 - 150

Die Tabellenwerte sind Richtwerte.
Es kann notwendig sein, die Werte den jeweiligen Bearbeitungsumständen anzupassen.



Material group	Structure of the material groups and identification letters		Brinell hardness HB	Tensile strength Rm (N/mm ²)	Chipping group	Cutting speed V _c (m/min)		
						coated	uncoated	
							AH7525	
P	Unalloyed steel	C ≤ 0.25 % annealed	125	428	P1	20 - 100 - 180	-	
		C > 0.25 ... ≤ 0.55 % annealed	190	639	P2	20 - 100 - 180	-	
		C > 0.25 ... ≤ 0.55 % hardened and tempered	210	708	P3	20 - 100 - 180	-	
		C > 0.55 % annealed	190	639	P4	20 - 100 - 180	-	
		C > 0.55 % hardened and tempered	300	1013	P5	20 - 100 - 180	-	
		Machining steel (short-chipping) tempered	220	745	P6	20 - 100 - 180	-	
	Low alloyed steel	annealed	175	591	P7	15 - 90 - 160	-	
		hardened and tempered	300	1013	P8	15 - 90 - 160	-	
		hardened and tempered	380	1282	P9	15 - 90 - 160	-	
		hardened and tempered	430	1477	P10	15 - 90 - 160	-	
	High alloyed steel and high alloyed tool steel	annealed	200	675	P11	20 - 70 - 120	-	
		hardened	300	1013	P12	20 - 70 - 120	-	
		hardened	400	1361	P13	20 - 70 - 120	-	
	Stainless steel	ferritic / martensitic, annealed	200	675	P14	20 - 55 - 90	-	
		martensitic, hardened and tempered	330	1114	P15	20 - 100 - 180	-	
M	Stainless steel	austenitic, chilled	200	675	M1	20 - 55 - 90	-	
		austenitic, precipitation-hardened (PH)	300	1013	M2	15 - 50 - 80	-	
		austenitic-ferritic, Duplex	230	778	M3	10 - 35 - 60	-	
K	Malleable cast iron	ferritic	200	675	K1	20 - 70 - 120	-	
		pearlitic	260	867	K2	20 - 70 - 120	-	
	Cast iron	low tensile strength	180	602	K3	20 - 80 - 140	-	
		high tensile strength / austenitic	245	825	K4	20 - 80 - 140	-	
	Cast iron with nodular graphite	ferritic	155	518	K5	20 - 75 - 130	-	
		pearlitic	265	885	K6	20 - 75 - 130	-	
GGV (CGI)		200	675	K7	20 - 70 - 120	-		
N	Aluminium alloys long chipping	not heat treatable	30	-	N1	20 - 260 - 500	-	
		heat treatable, heat treated	100	343	N2	20 - 260 - 500	-	
	Casted aluminium alloys	≤ 12 % Si, not heat treatable	75	260	N3	20 - 260 - 500	-	
		≤ 12 % Si, aushärtbar, ausgehärtet	90	314	N4	20 - 260 - 500	-	
		> 12 % Si, not heat treatable	130	447	N5	20 - 260 - 500	-	
	Magnesium alloys		70	250	N6	-	-	
	Copper and copper alloys (Brass / Bronze)	Unalloyed, elektrolyte copper	100	343	N7	20 - 310 - 600	-	
		Brass, Bronze	90	314	N8	20 - 310 - 600	-	
		Cu-alloys, short-chipping	110	382	N9	20 - 310 - 600	-	
		High-tensile, Ampco	300	1013	N10	-	-	
	Non-ferrous materials	Lead alloys (without abrasive filling material)	-	-	N11	-	-	
Duroplastic (without abrasive filling material)		-	-	N12	-	-		
Plastic glas fibre reinforced GFRP		-	-	N13	-	-		
Plastic carbon fibre reinforced CFRP		-	-	N14	-	-		
Plastic aramid fibre reinforced AFRP		-	-	N15	-	-		
Graphite (tech.)		80 Shore	-	N16	-	-		
S	High temperature resistant alloys	Fe-Basis	annealed	200	675	S1	15 - 45 - 75	-
			heat treated	280	943	S2	15 - 45 - 75	-
		Ni- or Co-alloyed	annealed	250	839	S3	15 - 30 - 40	-
			heat treated	350	1177	S4	15 - 30 - 40	-
			casting	320	1076	S5	15 - 30 - 40	-
	Titanium alloys	Pure titan	200	675	S6	-	-	
		α- and β-alloys, heat treated	375	1262	S7	-	-	
		β-alloys	410	1396	S8	-	-	
	Wolfram alloys		300	1013	S9	-	-	
	Molybdän alloys		300	1013	S10	-	-	
H	Hardened steel	hardened	50 HRC	-	H1	-	60 - 105 - 150	
		hardened	55 HRC	-	H2	-	60 - 105 - 150	
		hardened	60 HRC	-	H3	-	60 - 105 - 150	
	Hardened cast iron	hardened	55 HRC	-	H4	-	60 - 105 - 150	

The recommended cutting data are only approximate values. It may be necessary to adjust them to each individual machining application.

Gruppo materiale	Struttura dei gruppi di materiali e lettere di riferimento		Durezza Brinell	Resistenza Rm (N/mm ²)	Gruppo di lavoro	Velocità di taglio V _c (m/min)	
						rivestito	non rivestito
							AH7525
P	Acciai non legato	C ≤ 0,25 % ricotto	125	428	P1	20 - 100 - 180	-
		C > 0,25 ... ≤ 0,55 % ricotto	190	639	P2	20 - 100 - 180	-
		C > 0,25 ... ≤ 0,55 % bonificato	210	708	P3	20 - 100 - 180	-
		C > 0,55 % ricotto	190	639	P4	20 - 100 - 180	-
		C > 0,55 % bonificato	300	1013	P5	20 - 100 - 180	-
		Acciaio (truciolo corto) ricotto	220	745	P6	20 - 100 - 180	-
	Acciai debolmente legati	ricotto	175	591	P7	15 - 90 - 160	-
		bonificato	300	1013	P8	15 - 90 - 160	-
		bonificato	380	1282	P9	15 - 90 - 160	-
		bonificato	430	1477	P10	15 - 90 - 160	-
	Acciai fortemente legati e acciai da utensili	ricotto	200	675	P11	20 - 70 - 120	-
		temprato e rinvenuto	300	1013	P12	20 - 70 - 120	-
		temprato e rinvenuto	400	1361	P13	20 - 70 - 120	-
	Acciai inossidabili	ferritico / martensitico, ricotto	200	675	P14	20 - 55 - 90	-
		martensitico, bonificato	330	1114	P15	20 - 100 - 180	-
M	Acciai inossidabili	austenitico, trattato o temperato	200	675	M1	20 - 55 - 90	-
		austenitico, indurimento per precipitazione (PH)	300	1013	M2	15 - 50 - 80	-
		austenitico-ferritico, Duplex	230	778	M3	10 - 35 - 60	-
K	Ghisa temprata	ferritico	200	675	K1	20 - 70 - 120	-
		perlitica	260	867	K2	20 - 70 - 120	-
	Ghisa grigia	bassa resistenza	180	602	K3	20 - 80 - 140	-
		alta resistenza / austenitico	245	825	K4	20 - 80 - 140	-
	Ghisa sferoidale	ferritico	155	518	K5	20 - 75 - 130	-
		perlitica	265	885	K6	20 - 75 - 130	-
GGV (CGI)		200	675	K7	20 - 70 - 120	-	
N	Leghe di Alluminio stampato	non invecchiato	30	-	N1	20 - 260 - 500	-
		rinvenuto, invecchiato	100	343	N2	20 - 260 - 500	-
	Leghe di Alluminio da fusione	≤ 12 % Si, non invecchiato	75	260	N3	20 - 260 - 500	-
		≤ 12 % Si, rinvenuto, invecchiato	90	314	N4	20 - 260 - 500	-
		> 12 % Si, non invecchiato	130	447	N5	20 - 260 - 500	-
	Leghe di magnesio		70	250	N6	-	-
	Rame e Leghe di Rame (Bronzo / Ottone)	Non legati, Rame Elettrolitico	100	343	N7	20 - 310 - 600	-
		Ottone, Bronzo	90	314	N8	20 - 310 - 600	-
		Leghe Cu, truciolo corto	110	382	N9	20 - 310 - 600	-
		Alta resistenza, Ampco	300	1013	N10	-	-
Materiali non metallici	Leghe al piombo (senza materiale di riempimento abrasivo)	-	-	N11	-	-	
	Duroplastico (senza materiale di riempimento abrasivo)	-	-	N12	-	-	
	Plastica rinforzata in fibra di vetro GFRP	-	-	N13	-	-	
	Plastica rinforzata in fibra di carbonio CFRP	-	-	N14	-	-	
	Plastica rinforzata in fibra aramidica AFRP	-	-	N15	-	-	
	Grafite (tecnico)	80 Shore	-	N16	-	-	
S	Leghe resistenti al calore	Base-Fe ricotto	200	675	S1	15 - 45 - 75	-
		Base-Fe invecchiato	280	943	S2	15 - 45 - 75	-
		Base Ni o Co ricotto	250	839	S3	15 - 30 - 40	-
		Base Ni o Co invecchiato	350	1177	S4	15 - 30 - 40	-
		Base Ni o Co da fusione	320	1076	S5	15 - 30 - 40	-
	Leghe di Titanio	Titanio puro	200	675	S6	-	-
		Leghe α e β, invecchiato	375	1262	S7	-	-
		Leghe β	410	1396	S8	-	-
	Leghe di tungsteno		300	1013	S9	-	-
	Leghe di molibdeno		300	1013	S10	-	-
H	Acciaio Temprato	temprato e rinvenuto	50 HRC	-	H1	-	60 - 105 - 150
		temprato e rinvenuto	55 HRC	-	H2	-	60 - 105 - 150
		temprato e rinvenuto	60 HRC	-	H3	-	60 - 105 - 150
	Ghisa Temprata	temprato e rinvenuto	55 HRC	-	H4	-	60 - 105 - 150

I dati indicati in tabella sono valori approssimati. Può essere necessario adattarli alle singole applicazioni di lavorazione.



Recommended cutting data
Parametri di taglio suggeriti

Schnittdatenrichtwerte AH7525

Recommended cutting data AH7525

Parametri di taglio suggeriti AH7525

Durchmesser Diameter Diametro	Vc [m/min]	f [mm/U]	ap [mm]
2,0 mm – 3,0 mm	50–150	0,01–0,03	0,01–0,05
3,5 mm – 4,5 mm	50–150	0,01–0,05	0,01–0,10
5,0 mm – 6,0 mm	50–150	0,01–0,08	0,01–0,10

Schnittdatenrichtwerte Gewindedrehen – Anzahl der Durchgänge

Recommended cutting data – Threading – Number of passes

Parametri di taglio suggeriti – Filettatura – Numero di passate

Steigung Pitch Passo		Anzahl der Schnitte Number of passes Numero di passate					
Vc [m/min]		110–140	80–110	65–80	70–90	80–110	200–250
[mm]	Gang/Zoll Pitch/Inch Filetti/Pollice	Stahl Festigkeit [N/mm ²] Steel strength [N/mm ²] Acciaio resistenza (N/mm ²)			Rostfrei Stainless steel Acciaio inossidabile	Guss Cast Ghisa	Aluminium Aluminium Alluminio
		400–700	700–1.000	> 1.000			
0,5	48	6	7	7	8	7	6
0,75	32	8	9	9	10	9	8
0,8	32	8	9	10	10	9	8
1	24	10	11	12	12	12	10
1,25	20–19	12	14	15	15	14	12
1,5	16	15	17	18	18	17	15
1,75	14	17	19	21	21	18	17
2	12	19	22	25	25	20	18
2,5	10	22	26	31	31	22	20
3,0–3,5	8	28	32	38	38	24	22

Die hier aufgeführten Werte sind allgemeine Empfehlungen für die Anzahl der Durchgänge bei der Bearbeitung von normalen Stahl- und NE-Werkstoffen. Bei harten Werkstoffen ist die Schnitttiefe zu reduzieren und die Anzahl der Schnitte zu erhöhen. Bei Plattenbruch ist die Anzahl der Durchgänge zu erhöhen, bei hohem Verschleiß zu verringern.

HINWEIS: Der Spanquerschnitt sollte bei jedem Durchgang gleich groß sein, das heißt mit zunehmender Schnitttiefe ist die Zustellung zu reduzieren, um konstante Schnittkräfte zu erreichen.

The above mentioned data are general recommendations for machining steel and non-ferrous materials. With hard materials we recommend to reduce cutting speed and increase number of passes. By cutting edge breakage we suggest to increase number of passes, by edge wear reduce the number of passes.

Remark: The chip thickness should be constant at every pass, so with more cutting depth reduce the in-feed in order to obtain constant cutting forces.

I valori sopra indicati sono per materiali non trattati termicamente. Per materiali più duri ridurre le velocità di taglio e aumentare il numero di passate. In caso di scheggiature del tagliente si suggerisce di aumentare il numero delle passate, in caso di usura invece si suggerisce di ridurre il numero di passate.

NOTA: Lo spessore truciolo deve essere costante ad ogni passata. Per avere una sezione truciolo ed una forza di taglio costante durante la lavorazione adattare avanzamenti e profondità di passate.

Werkstoff und Bearbeitung

Material and application

Materiale e applicazione

ISO	Werkstoff Material Materiale	Max. Spantiefe a_p [mm] Max. depth of cut a_p [mm] Max prof. di taglio a_p [mm]	Bearbeitung Application Applicazione	Vorschubbereich Feed rate range Avanzamento
P	Stahl Steel Acciaio	0,5	Stechen, Einstechen Grooving Scanalatura	0,01 – 0,02
M	Rostfreier Stahl Stainless Steel Acciaio inossidabile	0,3	Bohrung ausdrehen und kopieren Boring, turning and copying Foratura, tornitura e copiatura	0,02 – 0,05
K	Guss Cast Fusioni	0,3	Vorstechen, Fasen, Rückwärtsdrehen Pre-grooving, chamfering and back turning Pre-scanalatura, smusso e in tirata	0,02 – 0,05
N	NE-Metalle, Aluminium Non-ferrous, Aluminium Alluminio e materiali non ferrosi	1,0	Axial-Stechedrehen Axial groove turning Scanalatura assiale	0,02 – 0,05

Einsatz-Beispiel

Application example

Esempio di applicazione

Bearbeitung Material 1.2343 mit 800 N/mm ² Application Material 1.2343 with 800 N/mm ² Applicazione Materiale 1.2343 con 800 N/mm ²	Gruppe Solution Utensile	Empfohlene Schnittwerte Recommended cutting data Parametri di taglio suggeriti	
		Drehzahl n (U/min) Revolution n (U/min) Giri n (U/min)	Vorschubbereich f (mm/U) Feed rate range f (mm/U) Avanzamento f (mm/U)
Vorbearbeitung Bohren \varnothing 10 mm Pre-machining, drilling \varnothing 10 mm Prelavorazione, foratura \varnothing 10 mm	SC10L-0023SP-05	3800	0,03
Vorbearbeitung Bohren \varnothing 6 mm Pre-machining, drilling \varnothing 6 mm Prelavorazione, foratura \varnothing 6 mm	SPC0060-0300 VHM / TiAIN	4200	0,1
Drehen, Kerndurchmesser M8 Turning to core diameter for M8 Tornitura preforo per M8	AMS-D-590802-200.60R	4200	0,04
Freistich, Gewinde Relief groove, thread Scanalatura, filettatura	AMS-S-59151800-200.60R	4200	0,02
Gewinde M8 Thread M8 Filettatura M8	AMS-G-M8-200.60R	1640	1,25
Drehen, Kontur Turning, form Tornitura, copiatura	AMS-K-591802-200.60R	3800	0,02 – 0,04

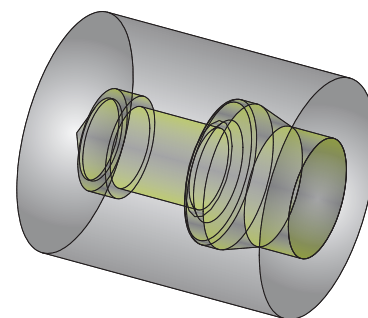

7

Montage ARNO®-Mini-System

Assembling of ARNO®-Mini-System

Montaggio di ARNO®-Mini-System

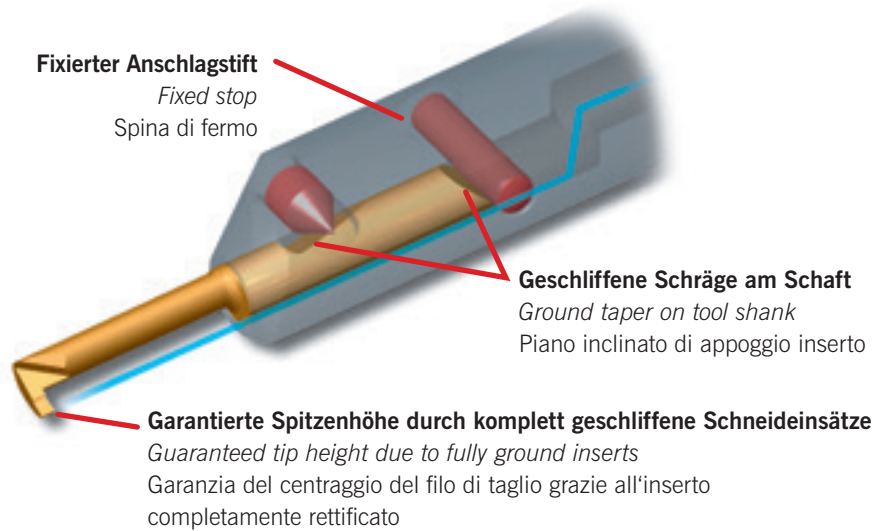

Die geschliffene Schräge am Schaft kombiniert mit dem Anschlagstift garantiert eine exakte radiale Fixierung des Schneideinsatzes bezüglich der Spitzenhöhe. Eine optimale Spannung des Schneideinsatzes erreichen Sie mittels Spannung des Gewindestiftes über die Kegelfläche.

With the ground taper on the tool shank and the fixed stop in the sleeve the length remains accurately constant and guaranteed cutting edge repeatability is achieved. The cone of the threaded pin ensures secure tool locking and reduces cutting edge vibrations.

Il piano inclinato di fermo oltre a garantire la perfetta ripetibilità dimensionale, assicura il posizionamento del tagliente in asse. Il piano di bloccaggio inclinato e la vite conica assicurano la massima tenuta e riducono la possibilità di vibrazioni.



8

SIM – Bohrstangen

SIM – Boring bars

SIM – Boreni

Innenbearbeitungssystem

Internal machining system

Sistema di lavorazione interna

• Systemvorstellung	• Introduction	• Caratteristiche del sistema	410 – 411
• Bohrstangen	• Boring bars	• Boreni	412 – 417
– Werkzeugauswahl	– Tool shank options	– Tipologie di corpo utensile	412 – 413
– Bezeichnungssystem	– Designation system	– Sistema di identificazione	414
– Bohrstangen	– Boring bars	– Boreni	415 – 417
• Schneideinsätze	• Inserts	• Inserti	419 – 433
– Sortenbeschreibung	– Grade description	– Descrizione delle Qualità	419
– Schneideinsätze	– Inserts	– Inserti	420 – 433
• Ersatzteile und Zubehör	• Spare parts and accessories	• Ricambi e accessori	434
• Schnittwerte	• Cutting data	• Parametri di taglio	436 – 442
• Anwendungshinweise	• Application reference	• Suggestimenti tecnici	442 – 444

Stirnseitig geschraubtes Werkzeugsystem ab Bohrungsdurchmesser 6,7 mm

Mini boring system with minimum bore diameter from 6.7 mm

Sistema di utensili modulare con serraggio frontale per diametri da 6,7 mm

Vorteile der Schnittstelle

Advantages of the patented location

Vantaggi del sistema brevettato di fissaggio inserto

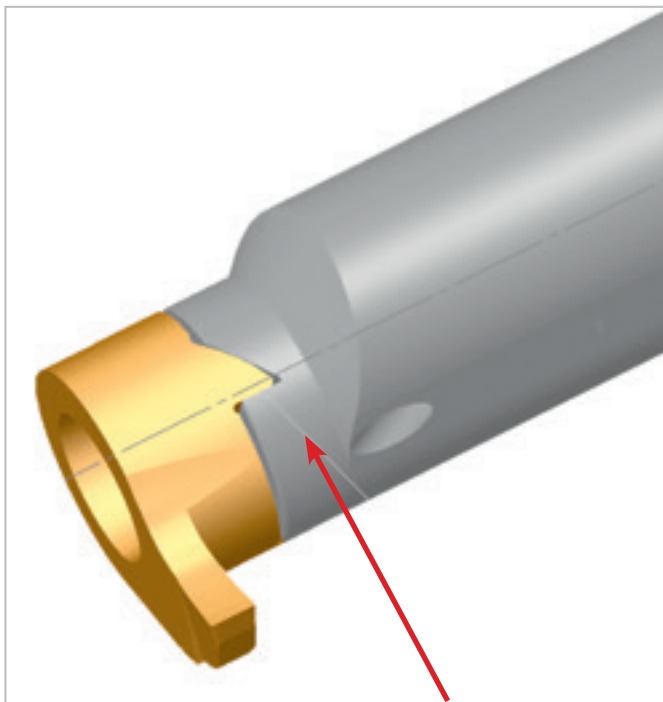

Rechtwinklige Anlageflächen
Optimale Kraftübertragung der Schnittkräfte durch rechtwinklige Anlageflächen.

Right angled location flat
Optimum transfer of locking forces due to right angled location.

Accoppiamento utensile/inserto
Trasferimento ottimale delle forze di serraggio date dalla geometria dell'accoppiamento.

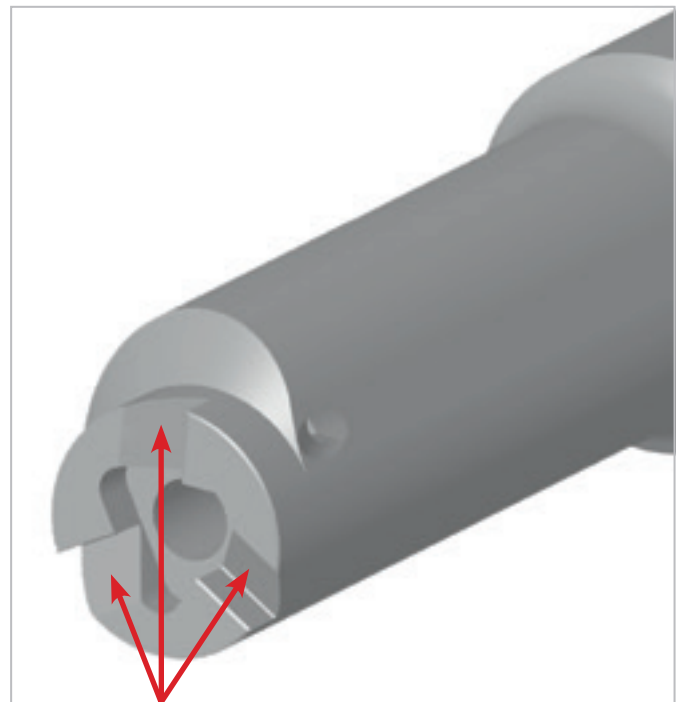

3-Punkt-Auflage
3-Punkt-Auflage garantiert eine exakte Wiederholgenauigkeit der Positionierung des Schneidkopfes.

3-point location
3-point location guarantees high repeatability and positioning of the insert.

3 punti di appoggio
Appoggio su 3 punti garantisce precisione e ripetibilità di posizionamento dell'inserto.

Systemvorstellung **Fakten**

Modulares Innenbearbeitungssystem in 5 Baugrößen, ab Bohrungsdurchmesser 6,7 mm. Trägerwerkzeuge in Stahl- und Hartmetallausführung kombiniert mit stirnseitig verschraubtem HM-Schneidkopf.

- Schwingungsarmer HM-Schaft mit gelötetem Stahlkopf
- Schaft mit zwei Spannflächen
- Innere Kühlmittelzufuhr
- Höchste Stabilität durch neue ovale Bauweise
- Auskraglänge bis 80 mm
- Stechtiefen bis 6 mm möglich
- Stechbreiten von 0,5 – 4 mm
- Einfaches Handling der Schneidköpfe
- Einsatzbereiche:
 - Radiuseinstiche
 - Seegering DIN 471/472
 - Kopieren
 - Vorstechen
 - Fasen
 - Gewinde
- Schneidköpfe mit abgestimmter PVD-Beschichtung
- Verfügbar in zwei Versionen: Stahl- und Vollhartmetall-Bohrstangen
- Sonderlösungen verfügbar

Introduction

SIM is a modular internal grooving system in 5 sizes starting at D_{min} 6.7 mm. Holders are available in steel or carbide execution (with brazed steel head) and screwed on carbide insert.

Features

- Vibration damped carbide shank with brazed steel head
- Shank has two location flats
- Through tool coolant
- Highest rigidity due to oval shaped shaft
- Reach into the bore up to 80 mm
- Depth of cut up to 4.5 mm
- Groove widths from 0.5 – 4 mm
- Easy insert replacement
- Application areas:
 - Radius grooving
 - Cir-clip grooving DIN 471/472
 - Copying
 - Pre-grooving
 - Chamfering
 - Threading
- Insert available with PVD coating
- Holders offered in steel and carbide execution
- Custom solutions on request

Descrizione

Sistema di scanalatura interna modulare in 5 dimensioni a partire da diametro di foro 6,7 mm. Corpi in acciaio e metallo duro con taglienti frontali in MD.

Caratteristiche

- Codolo in MD con testina in acciaio antivibrazioni
- Adattatore in acciaio con piani di bloccaggio
- Adduzione interna
- Elevata stabilità grazie alla sezione ovale
- Lunghezza fino a 80 mm
- Profondità gola fino a 4,5 mm
- Larghezza gola da 0,5 – 4 mm
- Facile sostituzione inserto
- Applicazioni:
 - Gole raggiate
 - Sedi seeger DIN471/472
 - Copiatura
 - Pre-scanalatura
 - Smusso
 - Filettatura
- Testina MD con rivestimento PVD
- Disponibile in due versioni: acciaio e metallo duro integrale
- Disponibili soluzioni speciali

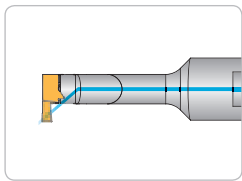
Übersicht Bohrstangen und Schneideinsätze / Program overview boring bars and inserts /
Gamma prodotti barani e inserti**Bohrstangen - Standard**

Boring bars - standard
Bareni - standard

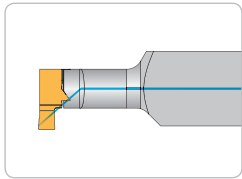
Seite / Page / Pagina **415****4-Kant-Halter**

Square holder
Adattatore a stelo quadro

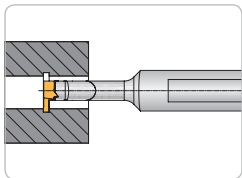
Seite / Page / Pagina **417****Schneideinsätze / Inserts / Inserti****Einstecken**

Grooving
Gole

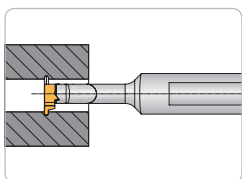
Seite / Page / Pagina **420****Radius-Einstich**

Radius grooving
Profilo a raggio pieno

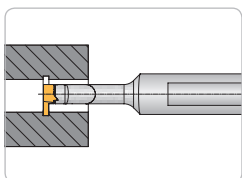
Seite / Page / Pagina **422****Seegering DIN 471/472**

Cir-clip grooving DIN 471/472
Sedi Seeger DIN 471/472

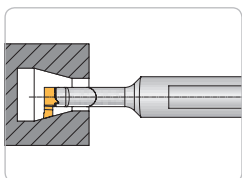
Seite / Page / Pagina **423****Kopieren 15°**

Copying 15°
Copiatura 15°

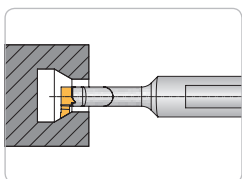
Seite / Page / Pagina **424****Kopieren 30°**

Copying 30°
Copiatura 30°

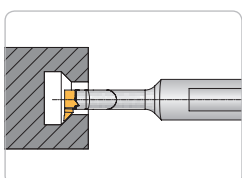
Seite / Page / Pagina **425****Kopieren 45°**

Copying 45°
Copiatura 45°

Seite / Page / Pagina **426**

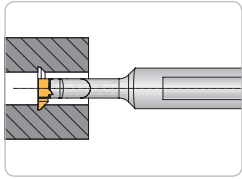
Übersicht Bohrstangen und Schneideinsätze / Program overview boring bars and inserts /
Gamma prodotti barani e inserti**Vorstechen und Fasen***Pre-grooving and chamfering*

Pre-scanalatura e smusso

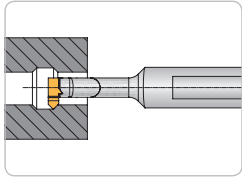
Seite/Page/Pagina **427****Fasen 45°***Chamfering 45°*

Smusso 45°

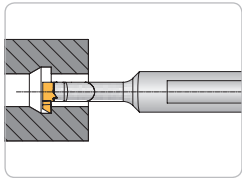
Seite/Page/Pagina **431****Rückwärtsdrehen***Back turning*

Lavorazione in tirata

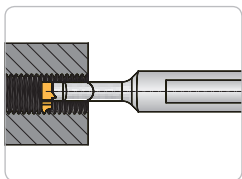
Seite/Page/Pagina **429****Gewinde 60° Metrisch-Teilprofil***Threading 60° Metric partial profile*

Filettatura 60° Metrica profilo parziale

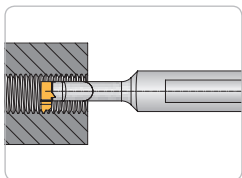
Seite/Page/Pagina **430****Gewinde 60° Metrisch-Vollprofil***Threading 60° Metric full profile*

Filettatura 60° Metrica profilo completo

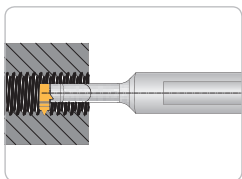
Seite/Page/Pagina **431****Whitworth Rohrgewinde 55° DIN ISO 228-Vollprofil***Whitworth pipe thread 55° DIN ISO 228-Full profile*

Filettatura Whitworth 55° DIN ISO 228-Profilo completo

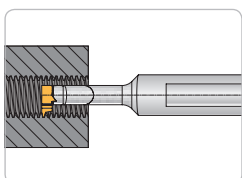
Seite/Page/Pagina **432****Trapezgewinde 30° DIN ISO 103-Teilprofil***Trapezoidal 30° DIN ISO 103-Partial profile*

Filettatura Trapezoidale 30° DIN ISO 103-Profilo parziale

Seite/Page/Pagina **433**

Bohrstangen / Boring bars / Barenì



Schneideinsätze / Inserts / Inserti

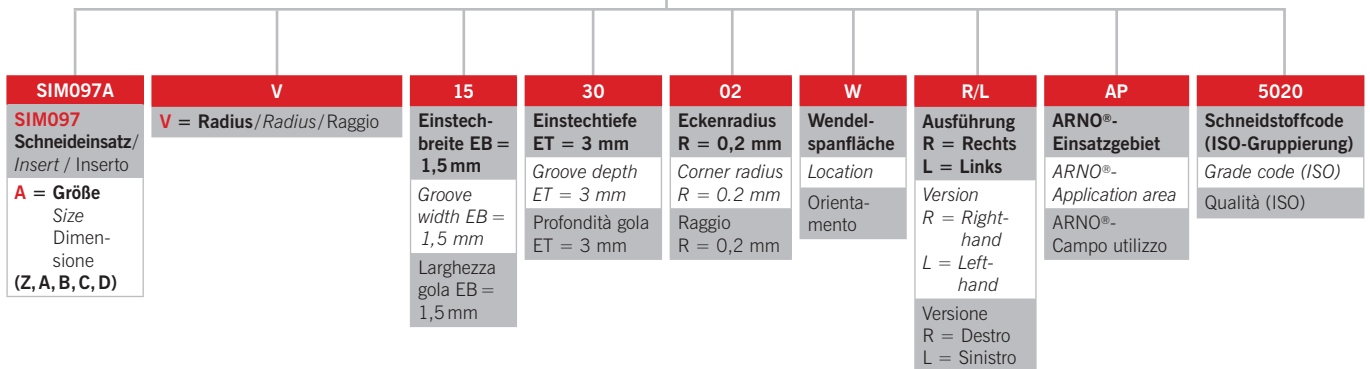

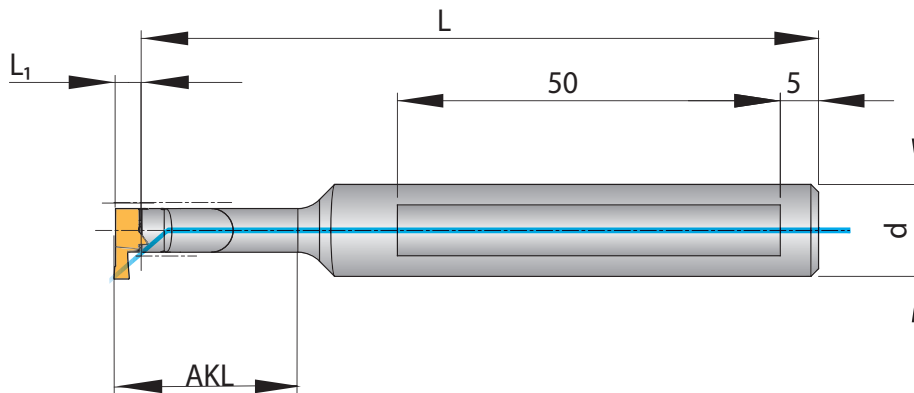
Bohrstangen - Standard / Boring bars - standard /
Bareni - standard

Trägerwerkzeuge / Holders / Utensili

HSIM-Z

Bezeichnung Designation Articolo	Größe Size Grandezza	d	L	L ₁	AKL	PG 12	Schneideinsatz Insert Inserto
HSIMZ-1012SL/R*	Z	12	76,5	3	10	●	SIM...Z...
HSIMZ-1812L/R	Z	12	84,5	3	18	●	SIM...Z...
HSIMZ-2012SL/R*	Z	12	86,5	3	20	●	SIM...Z...
HSIMZ-2612L/R	Z	12	92,5	3	26	●	SIM...Z...
HSIMZ-2612SL/R*	Z	12	92,5	3	26	●	SIM...Z...
HSIMZ-3612L/R	Z	12	102,5	3	36	●	SIM...Z...

HSIM-A

Bezeichnung Designation Articolo	Größe Size Grandezza	d	L	L ₁	AKL	PG 12	Schneideinsatz Insert Inserto
HSIMA-1212SL/R*	A	12	76,5	3,5	12	●	SIM...A...
HSIMA-1512L/R	A	12	79,5	3,5	15	●	SIM...A...
HSIMA-2412L/R	A	12	88,5	3,5	24	●	SIM...A...
HSIMA-2412SL/R*	A	12	88,5	3,5	24	●	SIM...A...
HSIMA-3212L/R	A	12	96,5	3,5	32	●	SIM...A...
HSIMA-4812L/R	A	12	111,5	3,5	48	●	SIM...A...

HSIM-B

Bezeichnung Designation Articolo	Größe Size Grandezza	d	L	L ₁	AKL	PG 12	Schneideinsatz Insert Inserto
HSIMB-1412SL/R*	B	12	75,5	4,5	14	●	SIM...B...
HSIMB-2912SL/R*	B	12	90,5	4,5	29	●	SIM...B...
HSIMB-4212L/R	B	12	105,5	4,5	42	●	SIM...B...
HSIMB-5612L/R	B	12	115,5	4,5	56	●	SIM...B...

*Stahlausführung

*Steel boring bar

*Corpo bareni in acciaio

Bohrstangen - Standard / Boring bars - standard / Bareni - standard

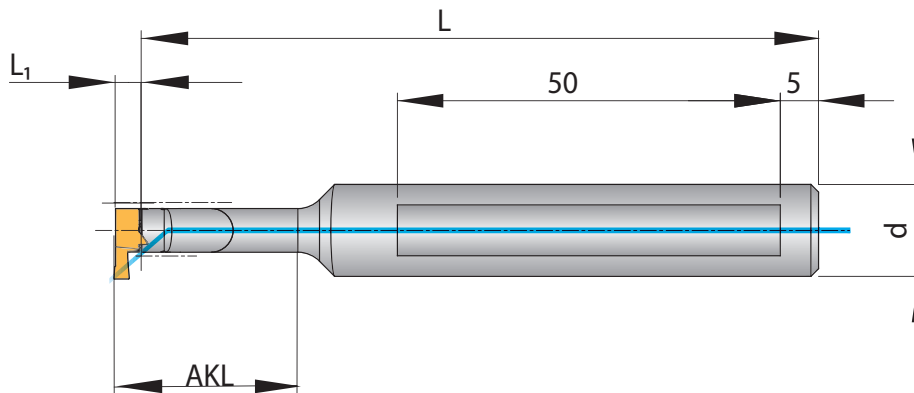

HSIM-C

Bezeichnung Designation Articolo	Größe Size Grandezza	d	L	L ₁	AKL	PG 12	Schneideinsatz Insert Inserto
HSIMC-1616SL/R*	C	16	77,5	4,5	16	●	SIM...C...
HSIMC-3416SL/R*	C	16	95,5	4,5	34	●	SIM...C...
HSIMC-4516L/R	C	16	105,5	4,5	45	●	SIM...C...
HSIMC-6416L/R	C	16	125,5	4,5	64	●	SIM...C...

HSIM-D

Bezeichnung Designation Articolo	Größe Size Grandezza	d	L	L ₁	AKL	PG 12	Schneideinsatz Insert Inserto
HSIMD-1816SL/R*	D	16	102,5	5,5	18	●	SIM...D...
HSIMD-4016L/R	D	16	124,5	5,5	40	●	SIM...D...
HSIMD-4016SL/R*	D	16	124,5	5,5	40	●	SIM...D...
HSIMD-5616L/R	D	16	124,5	5,5	56	●	SIM...D...
HSIMD-8016L/R	D	16	144,5	5,5	80	●	SIM...D...

*Stahlausführung

*Steel boring bar

*Corpo bareno in acciaio



Ersatzteile / Spare Parts / Ricambi

Bohrstangen - Größe Boring Bars - Size Bareni - Grandezza	Schraube Screw Vite	Schlüssel Key Chiave	Nm	Gewindegröße Thread size Filetto vite
HSIMZ- ..	AS 0030	T5107-IP	0,6	M 2,0
HSIMA- ..	AS 0031	T5108-IP	1,3	M 2,5
HSIMB- ..	AS 0032	T5109-IP	2,2	M 3,0
HSIMC- ..	AS 0033	T5110-IP	3,4	M 3,5
HSIMD- ..	AS 0034	T5115-IP	5,0	M 4,0

4-Kant-Halter / Square holder / Adattatore a stelo quadro

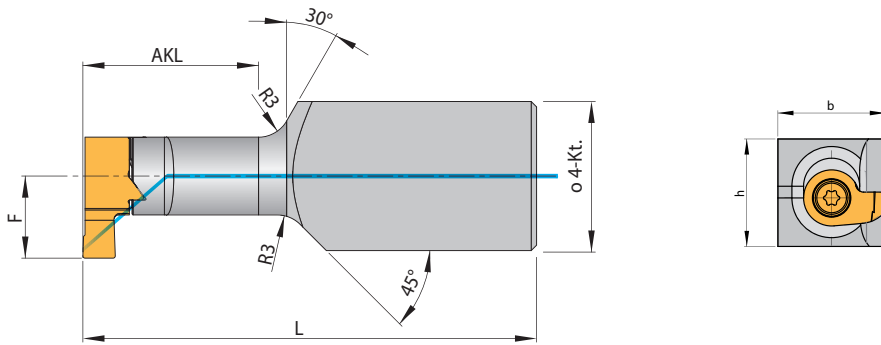

Trägerwerkzeuge / Holders / Utensili

Bezeichnung Designation Articolo	F	Größe Size Grandezza	h	b	AKL	L	PG 12	Schneideinsatz Insert Inserto
HSIMD-321220SL	10,1	D	12	20	32	100	●	SIM...D...

Ersatzteile / Spare Parts / Ricambi

Bohrstangen - Größe Boring Bars - Size Barni - Grandezza	Schraube Screw Vite	Schlüssel Key Chiave	Nm	Gewindegröße Thread size Filetto vite
HSIMD- ..	AS 0034	T5115-IP	5	M 4,0



**Sonderlösungen –
genau auf Sie zugeschnitten.**

*Special solutions especially
for your application!*

Soluzioni speciali –
su misura per voi.

**Sie haben eine Aufgabe –
wir haben die Lösung.**

Nutzen Sie unsere langjährige Erfahrung im Bereich der Sonderwerkzeuge und arbeiten Sie mit ARNO-Werkzeugen in Zukunft effektiver und kostengünstiger.

Ganz egal ob Sonderschneideinsätze oder komplexe Kombi-Werkzeuge – wir fertigen Ihnen flexibel, schnell und präzise nahezu jeden Wunsch.

**You have an application –
we have a solution.**

Take advantage of our many years' experience in special solutions and in future benefit from more efficient and cost effective ARNO tooling.

Whether it is special inserts or complex combination tools – we are able to offer nearly any solutions.

**Hai un problema –
chiedici la nostra soluzione.**

La nostra pluriennale esperienza nell'ambito delle lavorazioni meccaniche ci rende capaci di offrire qualsiasi soluzione di lavorazione nell'ambito delle nostre competenze specifiche.

Sia per singoli inserti o utensili e sia per complete combinazioni di utensili.

Un servizio veloce, flessibile e preciso per ogni esigenza.

Weitere Informationen finden Sie unter:

For more information see:

Altre informazioni su:

www.arno.de

Grade description

Descrizione delle Qualità

Beschichtet / Coated / Rivestito

AP5020

PVD-Mehrlagenbeschichtung

Zur Bearbeitung von Stählen, rostfreien Stählen und Gusswerkstoffen. Eine sehr universell einsetzbare Sorte mit hoher Hitze- und Oxidationsbeständigkeit.

PVD-multilayer coating

For machining steel, stainless steel and cast materials. Universal grade with high heat and oxidation resistance.

Rivestimento multiplo PVD

Grado studiato per un utilizzo universale. Idoneo alla lavorazione di acciai, acciai inossidabili e materiali stampati. Utilizzabile anche per la lavorazione di acciai molto legati o leghe resistenti al calore.

Unbeschichtet / Uncoated / Non rivestito

AK1020

Unbeschichtetes Feinkorn Hartmetall zur Bearbeitung von Aluminium und Nichteisenmetallen. Hervorragend geeignet als Basis-Substrat für kundenspezifische Beschichtungs-lösungen.

Uncoated fine grain carbide for machining aluminium and non-ferrous materials. Excellent also for material specific semi standard coatings.

Grado di Metallo duro Micrograna non rivestito studiato per la lavorazione di Alluminio, leghe non ferrose o materie plastiche. Ottima base per rivestimenti specifici.

Einstecken / Grooving / Scanalatura

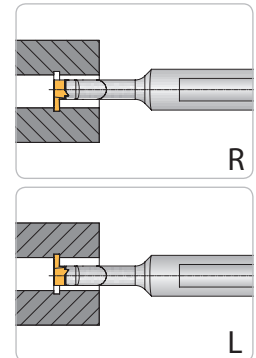
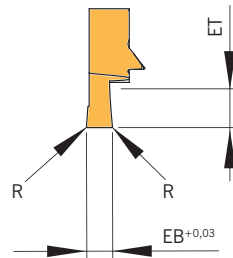
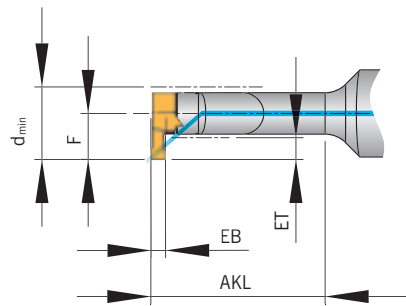

EB = Einsteckbreite [mm]
 ET = Einstehtiefe [mm]
 R = Radius
 EB = Einsteckbreite [mm]
 ET = Einstehtiefe [mm]
 R = Radius
 EB = Einsteckbreite [mm]
 ET = Einstehtiefe [mm]
 R = Radius

N NEU/NEW/
NUOVO

8

Bezeichnung Designation Articolo	Größe Size Grandezza	d _{min}	ET	EB	R	F	PG 15	
							beschichtet coated rivestito	unbeschichtet uncoated non rivestito
							AP5020	AK1020
SIM067Z-0510005WL/R	Z	6,7	1,0	0,5	0,05	3,85	●	●
SIM067Z-1010005WL/R	Z	6,7	1,0	1,0	0,05	3,85	●	●
SIM067Z-1510005WL/R	Z	6,7	1,0	1,5	0,05	3,85	●	●
SIM067Z-201001WL/R	Z	6,7	1,0	2,0	0,10	3,85	●	●
SIM077Z-0520005WL/R	Z	7,7	2,0	0,5	0,05	4,85	●	●
SIM077Z-1020005WL/R	Z	7,7	2,0	1,0	0,05	4,85	●	●
SIM077Z-1520005WL/R	Z	7,7	2,0	1,5	0,05	4,85	●	●
SIM077Z-202001WL/R	Z	7,7	2,0	2,0	0,10	4,85	●	●
SIM097A-1030005WL/R	A	9,7	3,0	1,0	0,05	6,35	●	●
SIM097A-1530005WL/R	A	9,7	3,0	1,5	0,05	6,35	●	●
SIM097A-153002WR	A	9,7	3,0	1,5	0,20	6,35	●	●
SIM097A-203001WL/R	A	9,7	3,0	2,0	0,10	6,35	●	●
SIM097A-253001WL/R	A	9,7	3,0	2,5	0,10	6,35	●	●
SIM097A-303002WL/R	A	9,7	3,0	3,0	0,20	6,35	●	●
SIM117B-071000WL/R	B	11,7	1,0	0,7	0,00	7,60	●	●
SIM117B-0730005WR	B	11,7	3,0	0,7	0,05	7,60	●	●
SIM117B-1035005WL/R	B	11,7	3,5	1,0	0,05	7,60	●	●
SIM117B-1535005WL/R	B	11,7	3,5	1,5	0,05	7,60	●	●
SIM117B-203501WL/R	B	11,7	3,5	2,0	0,10	7,60	●	●
SIM117B-253501WL/R	B	11,7	3,5	2,5	0,10	7,60	●	●
SIM117B-303502WL/R	B	11,7	3,5	3,0	0,20	7,60	●	●
SIM137C-1040005WL/R	C	13,7	4,0	1,0	0,05	8,85	●	●
SIM137C-1540005WL/R	C	13,7	4,0	1,5	0,05	8,85	●	●
SIM137C-204001WL/R	C	13,7	4,0	2,0	0,10	8,85	●	●
SIM137C-254001WL/R	C	13,7	4,0	2,5	0,10	8,85	●	●
SIM137C-304002WL/R	C	13,7	4,0	3,0	0,20	8,85	●	●
SIM157D-204501WL/R	D	15,7	4,5	2,0	0,10	10,10	●	●
SIM157D-254501WL/R	D	15,7	4,5	2,5	0,10	10,10	●	●
SIM157D-304502WL/R	D	15,7	4,5	3,0	0,20	10,10	●	●
SIM157D-354502WL/R	D	15,7	4,5	3,5	0,20	10,10	●	●

Inserts
Inserti

Einstecken / Grooving / Scanalatura

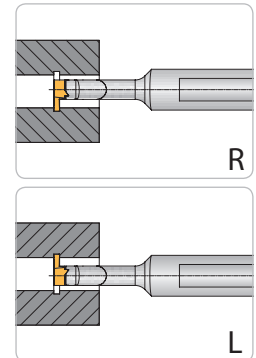
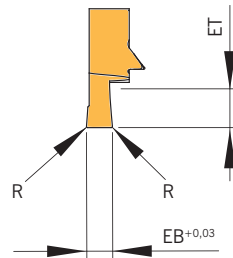
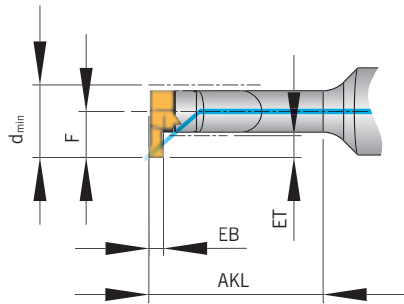

EB = Einsteckbreite [mm]
ET = Einstecktiefe [mm]
R = Radius
EB = Einsteckbreite [mm]
ET = Einstecktiefe [mm]
R = Radius
EB = Einsteckbreite [mm]
ET = Einstecktiefe [mm]
R = Radius

Bezeichnung Designation Articolo	Größe Size Grandezza	d _{min}	ET	EB	R	F	PG 15	
							beschichtet coated rivestito	unbeschichtet uncoated non rivestito
SIM157D-404502WL/R	D	15,7	4,5	4,0	0,20	10,10	●	●
SIM172D-206001WL/R	D	17,2	6,0	2,0	0,10	11,60	●	●
SIM172D-306002WL/R	D	17,2	6,0	3,0	0,20	11,60	●	●

P	●	
M	●	
K	●	
N	○	●
S	●	
H		

● Hauptanwendung
Main application
Applicazione principale
○ Nebenanwendung
Secondary application
Applicazione secondaria

Radius-Einstich / Radius grooving / Profilo a raggio pieno

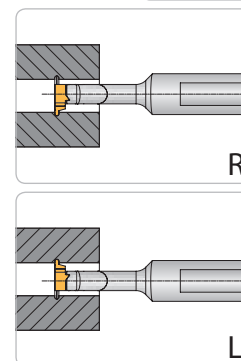
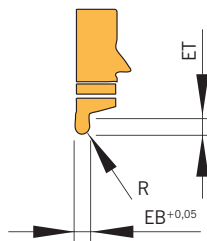
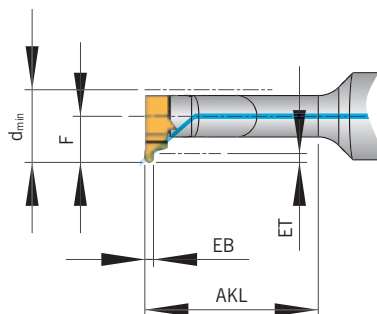

EB = Einstechbreite [mm]
 ET = Einstechtiefe [mm]
 R = Radius
 EB = Groove width [mm]
 ET = Groove depth [mm]
 R = Radius
 EB = Larghezza Gola [mm]
 ET = Profondità Gola [mm]
 R = Raggio di Punta

							PG 15	
							beschichtet coated rivestito	unbeschichtet uncoated non rivestito
Bezeichnung Designation Articolo	Größe Size Grandezza	d _{min}	ET	EB	R	F	AP5020	AK1020
SIM097A-V-081004L/R	A	9,7	1,0	0,8	0,4	6,35	●	●
SIM097A-V-121006L/R	A	9,7	1,0	1,2	0,6	6,35	●	●
SIM097A-V-181009L/R	A	9,7	1,0	1,8	0,9	6,35	●	●
SIM117B-V-082504L/R	B	11,7	2,5	0,8	0,4	7,60	●	●
SIM117B-V-102505L/R	B	11,7	2,5	1,0	0,5	7,60	●	●
SIM117B-V-122506L/R	B	11,7	2,5	1,2	0,6	7,60	●	●
SIM117B-V-182509L/R	B	11,7	2,5	1,8	0,9	7,60	●	●
SIM117B-V-202510L/R	B	11,7	2,5	2,0	1,0	7,60	●	●
SIM117B-V-302515L/R	B	11,7	2,5	3,0	1,5	7,60	●	●
SIM137C-V-124006L/R	C	13,7	4,0	1,2	0,6	8,85	●	●
SIM137C-V-184009L/R	C	13,7	4,0	1,8	0,9	8,85	●	●
SIM137C-V-204010L/R	C	13,7	4,0	2,0	1,0	8,85	●	●
SIM137C-V-224011L/R	C	13,7	4,0	2,2	1,1	8,85	●	●
SIM137C-V-304015L/R	C	13,7	4,0	3,0	1,5	8,85	●	●
SIM157D-V-184509L/R	D	15,7	4,5	1,8	0,9	10,10	●	●
SIM157D-V-224511L/R	D	15,7	4,5	2,2	1,1	10,10	●	●
SIM157D-V-304515L/R	D	15,7	4,5	3,0	1,5	10,10	●	●
SIM157D-V-404520L/R	D	15,7	4,5	4,0	2,0	10,10	●	●

P	●	
M	●	
K	●	
N	○	●
S	●	
H		

● Hauptanwendung
Main application
Applicazione principale
○ Nebenanwendung
Secondary application
Applicazione secondaria



Seegering DIN 471/472 / Cir-clip grooving DIN 471/472 /
Sedi Seeger DIN 471/472

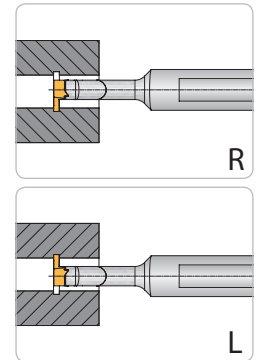
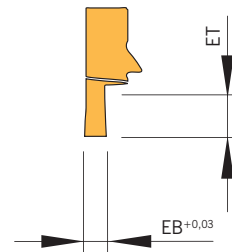
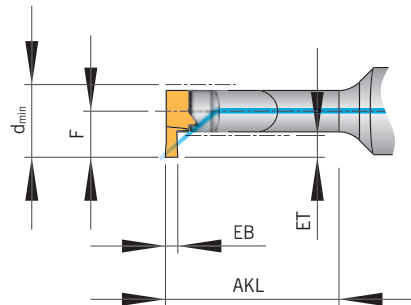

EB = Einstechbreite [mm]
ET = Einstechtiefe [mm]
EB = Groove width [mm]
ET = Groove depth [mm]
EB = Larghezza Gola [mm]
ET = Profondità Gola [mm]

Bezeichnung Designation Articolo	Größe Size Grandezza	d _{min}	ET	EB	F	PG 15	
						beschichtet coated rivestito	unbeschichtet uncoated non rivestito
						AP5020	AK1020
SIM097A-071000WL/R	A	9,7	1,0	0,73	6,35	●	●
SIM097A-081000WL/R	A	9,7	1,0	0,83	6,35	●	●
SIM097A-093000WL/R	A	9,7	3,0	0,93	6,35	●	●
SIM097A-113000WL/R	A	9,7	3,0	1,19	6,35	●	●
SIM097A-133000WL/R	A	9,7	3,0	1,39	6,35	●	●
SIM097A-163000WL/R	A	9,7	3,0	1,69	6,35	●	●
SIM117B-071000WL/R	B	11,7	1,0	0,70	7,60	●	●
SIM117B-081000WL/R	B	11,7	1,0	0,83	7,60	●	●
SIM117B-093500WL/R	B	11,7	3,5	0,93	7,60	●	●
SIM117B-113500WL/R	B	11,7	3,5	1,19	7,60	●	●
SIM117B-133500WL/R	B	11,7	3,5	1,39	7,60	●	●
SIM117B-163500WL/R	B	11,7	3,5	1,69	7,60	●	●
SIM137C-071000WL/R	C	13,7	1,0	0,73	8,85	●	●
SIM137C-081000WL/R	C	13,7	1,0	0,83	8,85	●	●
SIM137C-094000WL/R	C	13,7	4,0	0,93	8,85	●	●
SIM137C-114000WL/R	C	13,7	4,0	1,19	8,85	●	●
SIM137C-134000WL/R	C	13,7	4,0	1,39	8,85	●	●
SIM137C-164000WL/R	C	13,7	4,0	1,69	8,85	●	●
SIM157D-071000WL/R	D	15,7	1,0	0,73	10,10	●	●
SIM157D-081000WL/R	D	15,7	1,0	0,83	10,10	●	●
SIM157D-094500WL/R	D	15,7	4,5	0,93	10,10	●	●
SIM157D-114500WL/R	D	15,7	4,5	1,19	10,10	●	●
SIM157D-134500WL/R	D	15,7	4,5	1,39	10,10	●	●
SIM157D-164500WL/R	D	15,7	4,5	1,69	10,10	●	●

P	●	
M	●	
K	●	
N	○	●
S	●	
H		

● Hauptanwendung
Main application
Applicazione principale
○ Nebenanwendung
Secondary application
Applicazione secondaria



Kopieren 15° / Copying 15° / Copiatura 15°

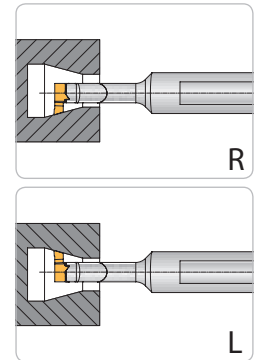
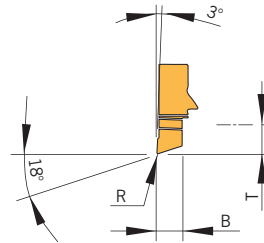
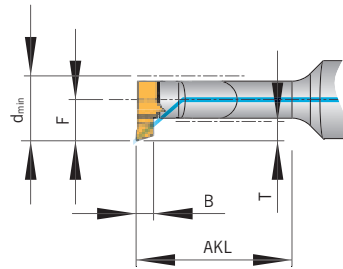

B = Breite [mm]
T = Nutztiefe [mm]
R = Radius
B = Groove width [mm]
T = Groove depth [mm]
R = Radius
B = Larghezza[mm]
T = Profondità [mm]
R = Raggio di Punta

							PG 15	
							beschichtet <i>coated</i> rivestito	unbeschichtet <i>uncoated</i> non rivestito
Bezeichnung <i>Designation</i> Articolo	Größe <i>Size</i> Grandezza	d_{min}	T	B	R	F	AP5020	AK1020
SIM067Z-K18-02L/R	Z	6,7	1,0	2,2	0,2	3,85	●	●
SIM067Z-K18-04L/R	Z	6,7	1,0	2,2	0,4	3,85	●	●
SIM097A-K18-02L/R	A	9,7	3,0	2,7	0,2	6,35	●	●
SIM117B-K18-02L/R	B	11,7	3,5	3,7	0,2	7,60	●	●
SIM137C-K18-02L/R	C	13,7	4,0	3,7	0,2	8,85	●	●
SIM157D-K18-02L/R	D	15,7	4,5	4,7	0,2	10,10	●	●

P	●	
M	●	
K	●	
N	○	●
S	●	
H		

● Hauptanwendung
Main application
 Applicazione principale
○ Nebenanwendung
Secondary application
 Applicazione secondaria



Kopieren 30° / Copying 30° / Copiatura 30°

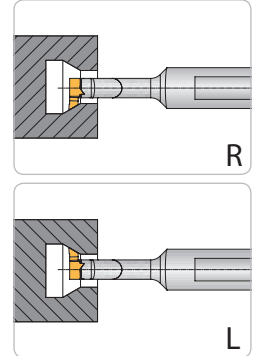
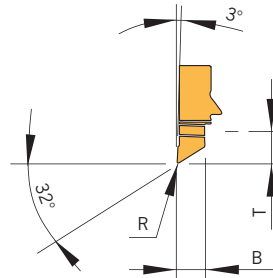
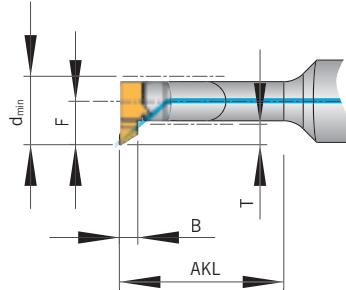

B = Breite [mm]
T = Nutztiefe [mm]
R = Radius
B = Groove width [mm]
T = Groove depth [mm]
R = Radius
B = Larghezza[mm]
T = Profondità [mm]
R = Raggio di Punta

							PG 15	
							beschichtet coated rivestito	unbeschichtet uncoated non rivestito
Bezeichnung Designation Articolo	Größe Size Grandezza	d _{min}	T	B	R	F	AP5020	AK1020
SIM097A-K32-02L/R	A	9,7	3,0	2,7	0,2	6,35	●	●
SIM117B-K32-02L/R	B	11,7	3,5	3,7	0,2	7,60	●	●
SIM137C-K32-02L/R	C	13,7	4,0	3,7	0,2	8,85	●	●
SIM157D-K32-02L/R	D	15,7	4,5	4,7	0,2	10,10	●	●

P	●	
M	●	
K	●	
N	○	●
S	●	
H		

● Hauptanwendung
Main application
Applicazione principale
○ Nebenanwendung
Secondary application
Applicazione secondaria



Kopieren 45° / Copying 45° / Copiatura 45°

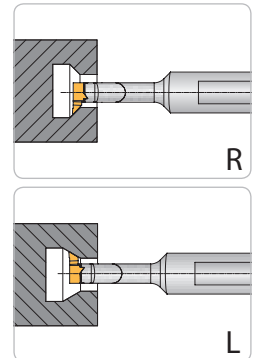
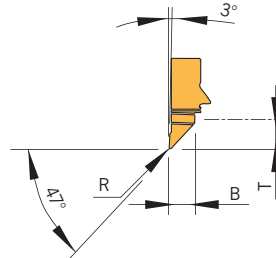
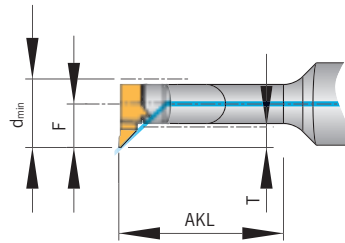
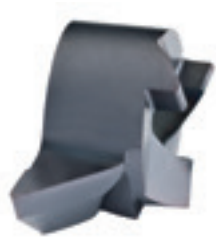

B = Breite [mm]
T = Nutztiefe [mm]
R = Radius
B = Groove width [mm]
T = Groove depth [mm]
R = Radius
B = Larghezza [mm]
T = Profondità [mm]
R = Raggio di Punta

							PG 15	
							beschichtet coated rivestito	unbeschichtet uncoated non rivestito
Bezeichnung Designation Articolo	Größe Size Grandezza	d _{min}	T	B	R	F	AP5020	AK1020
SIM097A-K47-02L/R	A	9,7	3,0	2,7	0,2	6,35	●	●
SIM117B-K47-02L/R	B	11,7	3,5	3,7	0,2	7,60	●	●
SIM137C-K47-02L/R	C	13,7	4,0	3,7	0,2	8,85	●	●
SIM157D-K47-02L/R	D	15,7	4,5	4,7	0,2	10,10	●	●

P	●	
M	●	
K	●	
N	○	●
S	●	
H		

● Hauptanwendung
Main application
Applicazione principale
○ Nebenanwendung
Secondary application
Applicazione secondaria



Vorstechen und Fasen / Pre-grooving and chamfering /
Pre-scanalatura e smusso

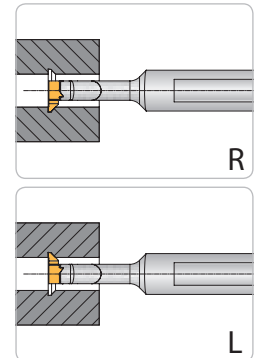
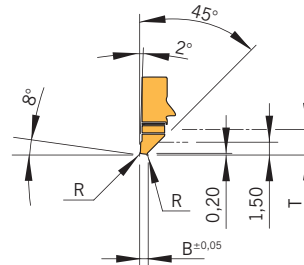
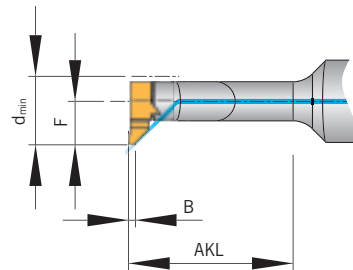

B = Breite [mm]
T = Nutztiefe [mm]
R = Radius
B = Groove width [mm]
T = Groove depth [mm]
R = Radius
B = Larghezza[mm]
T = Profondità [mm]
R = Raggio di Punta

							PG 15	
							beschichtet coated rivestito	unbeschichtet uncoated non rivestito
Bezeichnung Designation Articolo	Größe Size Grandezza	d _{min}	T	B	R	F	AP5020	AK1020
SIM097A-VF-0810-45L/R	A	9,7	3,0	1,0	0,1	6,35	●	●
SIM117B-VF-0810-45L/R	B	11,7	3,5	1,0	0,1	7,60	●	●
SIM137C-VF-0815-45L/R	C	13,7	4,0	1,5	0,1	8,85	●	●
SIM157D-VF-0815-45L/R	D	15,7	4,5	1,5	0,1	10,10	●	●

P	●	
M	●	
K	●	
N	○	●
S	●	
H		

● Hauptanwendung
Main application
Applicazione principale
○ Nebenanwendung
Secondary application
Applicazione secondaria



Fasen 45° / Chamfering 45° / Smusso 45°

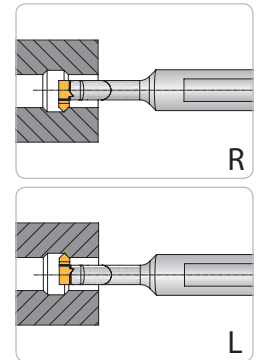
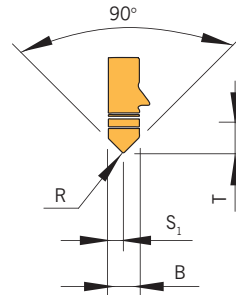
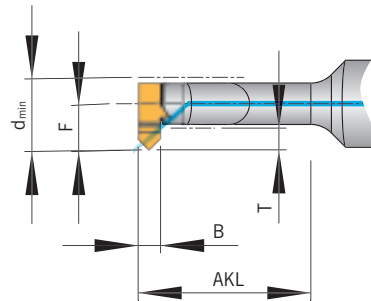

B = Breite [mm]
T = Nutztiefe [mm]
R = Radius
B = Groove width [mm]
T = Groove depth [mm]
R = Radius
B = Larghezza[mm]
T = Profondità [mm]
R = Raggio di Punta

								PG 15	
								beschichtet <i>coated</i> rivestito	unbeschichtet <i>uncoated</i> non rivestito
Bezeichnung <i>Designation</i> Articolo	Größe <i>Size</i> Grandezza	d _{min}	T	B	R	S ₁	F	AP5020	AK1020
SIM067Z-F45-02L/R	Z	6,7	1,0	2,2	0,2	1,1	3,85	●	●
SIM097A-F45-02L/R	A	9,7	3,0	3,0	0,2	1,5	6,35	●	●
SIM117B-F45-02L/R	B	11,7	3,5	4,0	0,2	2,0	7,60	●	●
SIM137C-F45-02L/R	C	13,7	4,0	4,0	0,2	2,0	8,85	●	●
SIM157D-F45-02L/R	D	15,7	4,5	5,0	0,2	2,5	10,10	●	●

P	●	
M	●	
K	●	
N	○	●
S	●	
H		

● Hauptanwendung
Main application
 Applicazione principale
○ Nebenanwendung
Secondary application
 Applicazione secondaria



Rückwärtsdrehen / Back turning / Lavorazione in tirata

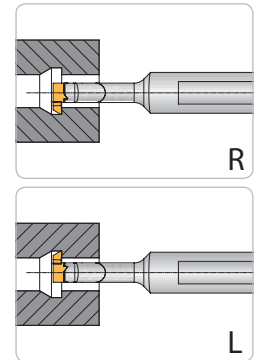
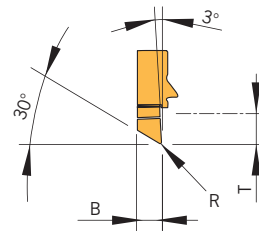
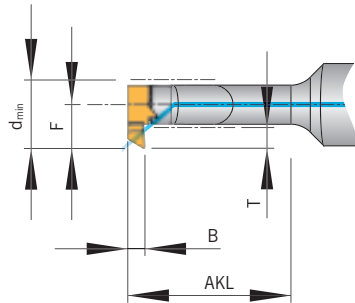

B = Breite [mm]
T = Nutztiefe [mm]
R = Radius
B = Groove width [mm]
T = Groove depth [mm]
R = Radius
B = Larghezza[mm]
T = Profondità [mm]
R = Raggio di Punta

							PG 15	
							beschichtet coated rivestito	unbeschichtet uncoated non rivestito
Bezeichnung Designation Articolo	Größe Size Grandezza	d _{min}	T	B	R	F	AP5020	AK1020
SIM067Z-R30-01L/R	Z	6,7	1,0	2,5	0,1	3,85	●	●
SIM097A-R30-02L/R	A	9,7	3,0	2,5	0,2	6,35	●	●
SIM117B-R30-02L/R	B	11,7	3,5	3,5	0,2	7,60	●	●
SIM137C-R30-02L/R	C	13,7	4,0	3,5	0,2	8,85	●	●
SIM157D-R30-02L/R	D	15,7	4,5	4,5	0,2	10,10	●	●

P	●	
M	●	
K	●	
N	○	●
S	●	
H		

● **Hauptanwendung**
Main application
Applicazione principale

○ **Nebenanwendung**
Secondary application
Applicazione secondaria



Gewinde 60° / Threading 60° / Filettatura 60°

Metrisch-Teilprofil / Metric-partial profile / Metrica profilo parziale

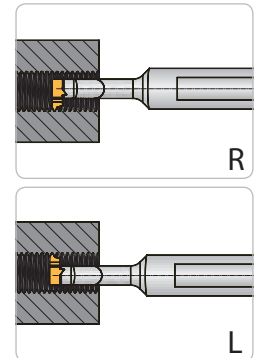
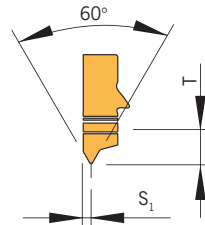
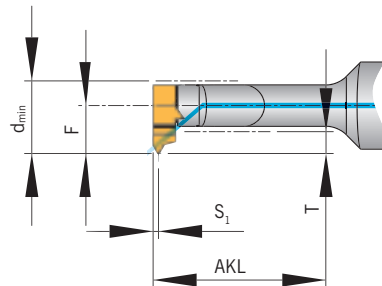
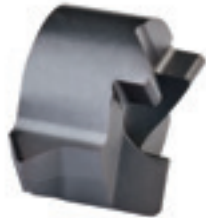

T = Nutztiefe [mm]
T = Groove depth [mm]
T = Profondità Gola [mm]

Bezeichnung Designation Articolo	Größe Size Grandezza	d _{min}	Typ Type Tipo	P Steigung P Pitch P Passo	S ₁	T	F	PG 15	
								beschichtet coated rivestito	unbeschichtet uncoated non rivestito
								AP5020	AK1020
SIM067Z-G-MF050100L/R	Z	6,7	MF	0,5 - 1,0	0,8	1,0	3,85	●	●
SIM067Z-G-M125L/R	Z	6,7	M	1,25	0,8	1,0	3,85	●	●
SIM080A-G-MF050075L/R	A	8,0	MF	0,5 - 0,75	0,8	1,8	4,85	●	●
SIM080A-G-MF100125L/R	A	8,0	MF	1,0 - 1,25	0,8	1,8	4,85	●	●
SIM080A-G-M150175L/R	A	8,0	M	1,5 - 1,75	1,0	1,8	4,85	●	●
SIM107B-G-MF050075L/R	B	10,7	MF	0,5 - 0,75	0,8	3,0	6,80	●	●
SIM107B-G-MF100125L/R	B	10,7	MF	1,0 - 1,25	0,8	3,0	6,80	●	●
SIM107B-G-MF150175L/R	B	10,7	MF	1,5 - 1,75	1,0	3,0	6,80	●	●
SIM107B-G-M200L/R	B	10,7	M	2,00	1,3	3,0	6,80	●	●
SIM107B-G-M250L/R	B	10,7	M	2,50	1,4	3,0	6,80	●	●
SIM137C-G-MF050075L/R	C	13,7	MF	0,5 - 0,75	0,8	4,2	8,85	●	●
SIM137C-G-MF100125L/R	C	13,7	MF	1,0 - 1,25	0,8	4,2	8,85	●	●
SIM137C-G-MF150175L/R	C	13,7	MF	1,5 - 1,75	1,0	4,2	8,85	●	●
SIM137C-G-M200L/R	C	13,7	M	2,00	1,3	4,2	8,85	●	●
SIM137C-G-M250L/R	C	13,7	M	2,50	1,4	4,2	8,85	●	●
SIM157D-G-MF100125L/R	D	15,7	MF	1,0 - 1,25	0,8	4,7	10,10	●	●
SIM157D-G-MF150175L/R	D	15,7	MF	1,5 - 1,75	1,0	4,7	10,10	●	●
SIM157D-G-MF200L/R	D	15,7	MF	2,00	1,3	4,7	10,10	●	●
SIM157D-G-M250L/R	D	15,7	M	2,50	1,4	4,7	10,10	●	●

M = ISO-Innengewinde Metrisch
M = ISO-Metric
M = Filettatura Metrica ISO
MF = ISO-Innengewinde Metrisch Fein
MF = ISO-Metric - Fine
MF = Filettatura Metrica ISO - Passo Fine

P	●	
M	●	
K	●	
N	○	●
S	●	
H		

● Hauptanwendung
Main application
Applicazione principale
○ Nebenanwendung
Secondary application
Applicazione secondaria

Gewinde 60° / Threading 60° / Filettatura 60°

Metrisch-Vollprofil / Metric-full profile / Metrica profilo completo

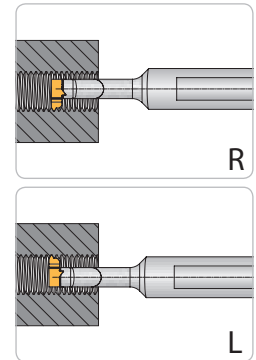
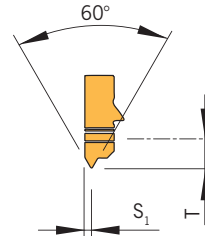
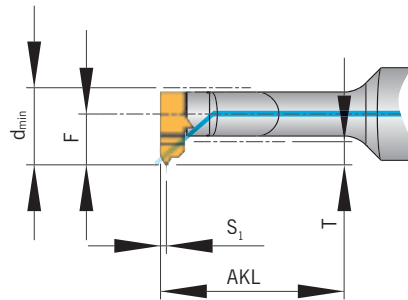

T = Nutztiefe [mm]
T = Groove depth [mm]
T = Profondità Gola [mm]

								PG 15	
								beschichtet coated rivestito	unbeschichtet uncoated non rivestito
Bezeichnung Designation Articolo	Größe Size Grandezza	d _{min}	Typ Type Tipo	P Steigung P Pitch P Passo	S ₁	T	F	AP5020	AK1020
SIM080A-GV-M150L/R	A	8,0	M	1,5	1,0	1,8	4,85	●	●
SIM107B-GV-M200L/R	B	10,7	M	2,0	1,3	3,0	6,80	●	●
SIM107B-GV-MF100L/R	B	10,7	MF	1,0	0,8	3,0	6,80	●	●
SIM107B-GV-MF150L/R	B	10,7	MF	1,5	1,0	3,0	6,80	●	●
SIM107B-GV-M250L/R	B	10,7	M	2,5	1,4	3,0	6,80	●	●
SIM107B-GV-M300L/R	B	10,7	M	3,0	1,6	3,0	6,80	●	●
SIM137C-GV-MF100L/R	C	13,7	MF	1,0	0,8	4,2	8,85	●	●
SIM137C-GV-MF150L/R	C	13,7	MF	1,5	1,0	4,2	8,85	●	●
SIM137C-GV-M200L/R	C	13,7	M	2,0	1,3	4,2	8,85	●	●
SIM137C-GV-M250L/R	C	13,7	M	2,5	1,4	4,2	8,85	●	●
SIM157D-GV-M250L/R	D	15,7	M	2,5	1,4	4,7	10,10	●	●
SIM157D-GV-M300L/R	D	15,7	M	3,0	1,6	4,7	10,10	●	●
SIM157D-GV-M350L/R	D	15,7	M	3,5	1,8	4,7	10,10	●	●
SIM157D-GV-M400L/R	D	15,7	M	4,0	2,0	4,7	10,10	●	●
SIM157D-GV-MF100L/R	D	15,7	MF	1,0	0,8	4,7	10,10	●	●
SIM157D-GV-MF150L/R	D	15,7	MF	1,5	1,0	4,7	10,10	●	●
SIM157D-GV-MF200L/R	D	15,7	MF	2,0	1,3	4,7	10,10	●	●

M = ISO-Innengewinde Metrisch
M = ISO-Metric
M = Filettatura Metrica ISO
MF = ISO-Innengewinde Metrisch Fein
MF = ISO-Metric - Fine
MF = Filettatura Metrica ISO - Passo Fine

P	●	
M	●	
K	●	
N	○	●
S	●	
H		

● Hauptanwendung
Main application
Applicazione principale
○ Nebenanwendung
Secondary application
Applicazione secondaria



**Whitworth Rohrgewinde 55° / Whitworth pipe thread 55° /
Filettatura Whitworth 55°**

**DIN ISO 228 - Vollprofil / DIN ISO 228 - Full profile /
DIN ISO 228 - Profilo completo**

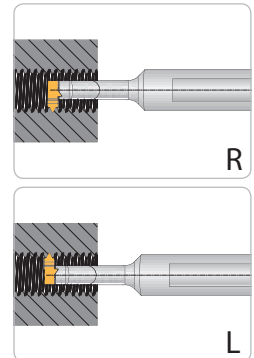
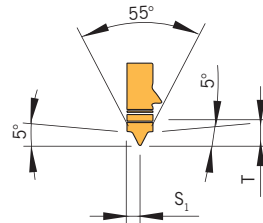
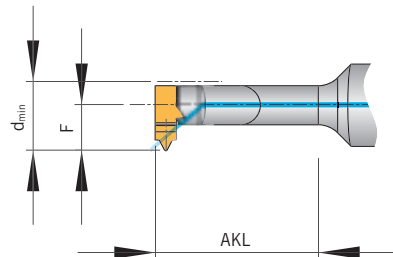

T = Nutztiefe [mm]
T = Groove depth [mm]
T = Profondità Gola [mm]

Bezeichnung Designation Articolo	Größe Size Grandezza	d _{min}	Typ Type Tipo	P Steigung P Pitch P Passo	G/Inch TPI G/Inch	S ₁	T	F	PG 15	
									beschichtet coated rivestito	unbeschichtet uncoated non rivestito
									AP5020	AK1020
SIM157D-GV-W228/11L/R	D	15,7	W228	2,309	11	2,0	4,7	10,1	●	●
SIM157D-GV-W228/14L/R	D	15,7	W228	1,814	14	1,6	4,7	10,1	●	●
SIM107B-GV-W228/14L/R	B	10,7	W228	1,814	14	1,6	3,0	6,8	●	●
SIM107B-GV-W228/19L/R	B	10,7	W228	1,337	19	1,3	3,0	6,8	●	●

P	●	
M	●	
K	●	
N	○	●
S	●	
H		

● Hauptanwendung
Main application
Applicazione principale
○ Nebenanwendung
Secondary application
Applicazione secondaria



Trapezgewinde 30° / Trapezoidal 30° / Filettatura Trapezoidale 30°
DIN ISO 103-Teilprofil / DIN ISO 103-Profilo parziale / ISO 103-Partial profile

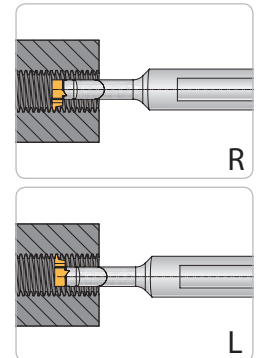
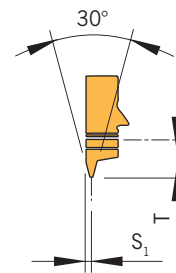
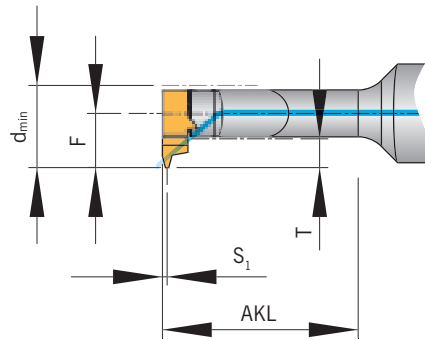

T = Nutztiefe [mm]
 T = Groove depth [mm]
 T = Profondità Gola [mm]

								PG 15	
								beschichtet coated rivestito	unbeschichtet uncoated non rivestito
Bezeichnung Designation Articolo	Größe Size Grandezza	d _{min}	Typ Type Tipo	P Steigung P Pitch P Passo	S ₁	T	F	AP5020	AK1020
SIM082A-G-TR103/1,5L/R	A	8,2	TR103	1,5	0,6	1,9	4,85	●	●
SIM087A-G-TR103/2,0L/R	A	8,7	TR103	2,0	1,0	2,4	4,85	●	●
SIM087A-G-TR103/3,0L/R	A	8,7	TR103	3,0	1,2	2,4	4,85	●	●
SIM107B-G-TR103/1,5L/R	B	10,7	TR103	1,5	0,6	3,0	6,80	●	●
SIM107B-G-TR103/2,0L/R	B	10,7	TR103	2,0	1,0	3,0	6,80	●	●
SIM107B-G-TR103/3,0L/R	B	10,7	TR103	3,0	1,2	3,0	6,80	●	●
SIM107B-G-TR103/4,0L/R	B	10,7	TR103	4,0	1,6	3,0	6,80	●	●
SIM137C-G-TR103/4,0L/R	C	13,7	TR103	4,0	1,6	4,2	8,85	●	●
SIM137C-G-TR103/5,0L/R	C	13,7	TR103	5,0	2,0	4,2	8,85	●	●
SIM157D-G-TR103/2,0L/R	D	15,7	TR103	2,0	1,0	4,7	10,10	●	●
SIM157D-G-TR103/3,0L/R	D	15,7	TR103	3,0	1,2	4,7	10,10	●	●
SIM157D-G-TR103/4,0L/R	D	15,7	TR103	4,0	1,6	4,7	10,10	●	●
SIM157D-G-TR103/5,0L/R	D	15,7	TR103	5,0	2,0	4,7	10,10	●	●
SIM157D-G-TR103/6,0L/R	D	15,7	TR103	6,0	2,2	4,7	10,10	●	●

P	●	
M	●	
K	●	
N	○	●
S	●	
H		

● Hauptanwendung
 Main application
 Applicazione principale
 ○ Nebenanwendung
 Secondary application
 Applicazione secondaria



Spare parts and accessories
Ricambi e accessori

Artikel / Item / Articolo	PG 11
Schraube / Screw / Vite	
AS 0030	●
AS 0031	●
AS 0032	●
AS 0033	●
AS 0034	●
Schlüssel / Key / Chiave	
T5107-IP	●
T5108-IP	●
T5109-IP	●
T5110-IP	●
T5115-IP	●

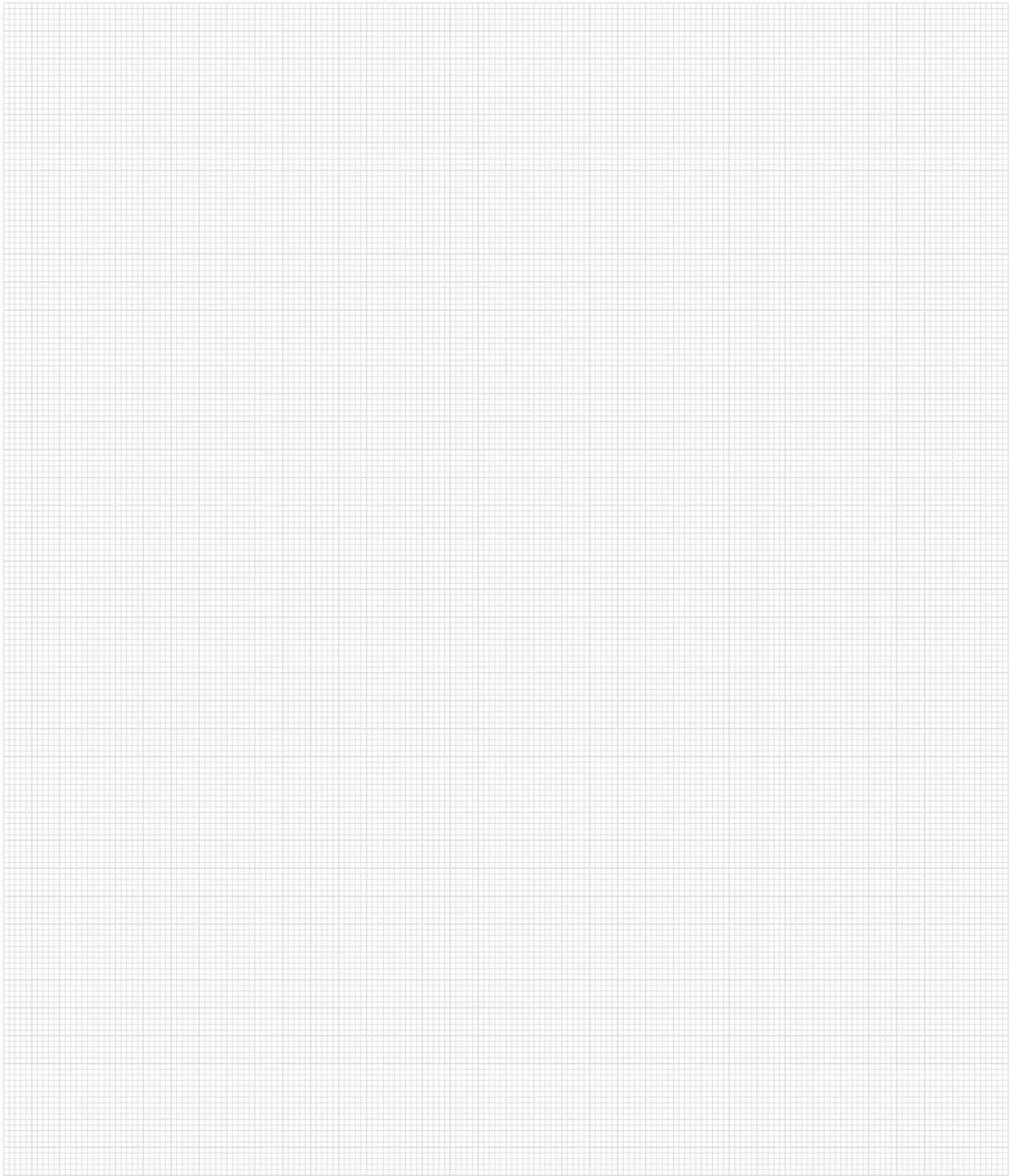

ARNO®
WERKZEUGE

Weitere Informationen finden Sie unter:

For more information see:

Per maggiori informazioni visita il sito:

www.arno.de

Werkstoff- gruppe	Gliederung der Werkstoffhauptgruppen und Kennbuchstaben		Brinell-Härte	Zugfestigkeit (N/mm ²)	Zerspanungsgruppe	Schnittgeschwindigkeit V _c (m/min)	
						beschichtet	unbeschichtet
						AP5020	AK1020
P	Unlegierter Stahl	C ≤ 0,25 % geglüht	125	428	P1	20 - 100 - 180	20 - 75 - 130
		C > 0,25 ... ≤ 0,55 % geglüht	190	639	P2	20 - 100 - 180	20 - 75 - 130
		C > 0,25 ... ≤ 0,55 % vergütet	210	708	P3	20 - 100 - 180	20 - 75 - 130
		C > 0,55 % geglüht	190	639	P4	20 - 100 - 180	20 - 75 - 130
		C > 0,55 % vergütet	300	1013	P5	20 - 100 - 180	20 - 75 - 130
		Automatenstahl (kurzspanend) geglüht	220	745	P6	20 - 100 - 180	20 - 75 - 130
	Niedrig legierter Stahl	geglüht	175	591	P7	15 - 90 - 160	15 - 65 - 110
		vergütet	300	1013	P8	15 - 90 - 160	15 - 65 - 110
		vergütet	380	1282	P9	15 - 90 - 160	15 - 65 - 110
		vergütet	430	1477	P10	15 - 90 - 160	15 - 65 - 110
	Hochlegierter Stahl und hochlegierter Werkzeugstahl	geglüht	200	675	P11	20 - 70 - 120	20 - 55 - 85
		gehärtet und angelassen	300	1013	P12	20 - 70 - 120	20 - 55 - 85
		gehärtet und angelassen	400	1361	P13	20 - 70 - 120	20 - 55 - 85
	Nichtrostender Stahl	ferritisch / martensitisch, geglüht	200	675	P14	20 - 55 - 90	20 - 40 - 60
martensitisch, vergütet		330	1114	P15	20 - 100 - 180	20 - 40 - 60	
M	Nichtrostender Stahl	austenitisch, abgeschreckt	200	675	M1	15 - 50 - 80	15 - 45 - 70
		austenitisch, ausscheidungsgehärtet (PH)	300	1013	M2	20 - 65 - 110	15 - 50 - 80
		austenitisch-ferritisch, Duplex	230	778	M3	10 - 35 - 60	10 - 25 - 40
K	Temperguss	ferritisch	200	675	K1	20 - 85 - 150	20 - 70 - 120
		perritisch	260	867	K2	20 - 85 - 150	20 - 70 - 120
	Grauguss	niedrige Festigkeit	180	602	K3	20 - 90 - 160	20 - 65 - 110
		hohe Festigkeit / austenitisch	245	825	K4	20 - 90 - 160	20 - 65 - 110
	Gusseisen mit Kugelgraphit	ferritisch	155	518	K5	20 - 85 - 150	20 - 65 - 110
		perritisch	265	885	K6	20 - 85 - 150	20 - 65 - 110
GGV (CGI)		200	675	K7	20 - 85 - 150	20 - 70 - 120	
N	Aluminium-Knetlegierungen	nicht aushärtbar	30	-	N1	20 - 310 - 600	20 - 260 - 500
		aushärtbar, ausgehärtet	100	343	N2	20 - 310 - 600	20 - 260 - 500
		≤ 12 % Si, nicht aushärtbar	75	260	N3	20 - 310 - 600	20 - 260 - 500
	Aluminium-Gusslegierungen	≤ 12 % Si, aushärtbar, ausgehärtet	90	314	N4	20 - 310 - 600	20 - 260 - 500
		> 12 % Si, nicht aushärtbar	130	447	N5	20 - 310 - 600	20 - 260 - 500
	Magnesiumlegierungen		70	250	N6	-	-
	Kupfer und Kupferlegierungen (Bronze / Messing)	unlegiert, Elektrolytkupfer	100	343	N7	20 - 310 - 600	15 - 260 - 500
		Messing, Bronze, Rotguss	90	314	N8	20 - 310 - 600	15 - 260 - 500
		Cu-Legierung, kurzspanend	110	382	N9	20 - 310 - 600	15 - 260 - 500
		hochfest, Ampco	300	1013	N10	-	-
Nichtmetallische Werkstoffe	Thermoplaste (ohne abrasive Füllstoffe)	-	-	N11	-	-	
	Duroplaste (ohne abrasive Füllstoffe)	-	-	N12	-	-	
	Kunststoff glasfaserverstärkt GFRP	-	-	N13	-	-	
	Kunststoff kohlefaserverstärkt CFRP	-	-	N14	-	-	
	Kunststoff aramidfaserverstärkt AFRP	-	-	N15	-	-	
	Graphit (technisch)	80 Shore	-	N16	-	-	
S	Warmfeste Legierungen	Fe-Basis geglüht	200	675	S1	15 - 45 - 75	15 - 25 - 30
		ausgehärtet	280	943	S2	15 - 45 - 75	15 - 25 - 30
		geglüht	250	839	S3	15 - 30 - 40	15 - 30 - 40
		Ni- oder Co-Basis ausgehärtet	350	1177	S4	15 - 30 - 40	15 - 30 - 40
		gegossen	320	1076	S5	15 - 30 - 40	15 - 30 - 40
	Titanlegierungen	Reintitan	200	675	S6	-	-
		α- und β-Legierungen, ausgehärtet	375	1262	S7	-	-
		β-Legierungen	410	1396	S8	-	-
	Wolframlegierungen		300	1013	S9	-	-
	Molybdänlegierungen		300	1013	S10	-	-
H	Gehärteter Stahl	gehärtet und angelassen	50 HRC	-	H1	-	-
		gehärtet und angelassen	55 HRC	-	H2	-	-
		gehärtet und angelassen	60 HRC	-	H3	-	-
	Gehärtetes Gusseisen	gehärtet und angelassen	55 HRC	-	H4	-	-

Die Tabellenwerte sind Richtwerte.
Es kann notwendig sein, die Werte den jeweiligen Bearbeitungsumständen anzupassen.



Werkstoff- gruppe	Gliederung der Werkstoffhauptgruppen und Kennbuchstaben		Brinell-Härte	Zugfestigkeit (N/mm ²)	Zerspanungsgruppe	Schnittgeschwindigkeit V _c (m/min)	
						beschichtet	unbeschichtet
						AP5020	AK1020
P	Unlegierter Stahl	C ≤ 0,25 % geglüht	125	428	P1	80 - 115 - 150	80 - 95 - 110
		C > 0,25 ... ≤ 0,55 % geglüht	190	639	P2	80 - 115 - 150	80 - 95 - 110
		C > 0,25 ... ≤ 0,55 % vergütet	210	708	P3	60 - 90 - 120	60 - 75 - 90
		C > 0,55 % geglüht	190	639	P4	80 - 115 - 150	80 - 95 - 110
		C > 0,55 % vergütet	300	1013	P5	60 - 90 - 120	60 - 75 - 90
		Automatenstahl (kurzspanend) geglüht	220	745	P6	80 - 115 - 150	80 - 95 - 110
	Niedrig legierter Stahl	geglüht	175	591	P7	70 - 100 - 130	70 - 85 - 100
		vergütet	300	1013	P8	70 - 95 - 120	70 - 80 - 90
		vergütet	380	1282	P9	70 - 95 - 120	70 - 80 - 90
		vergütet	430	1477	P10	70 - 95 - 115	70 - 80 - 85
	Hochlegierter Stahl und hochlegierter Werkzeugstahl	geglüht	200	675	P11	60 - 85 - 110	60 - 70 - 80
		gehärtet und angelassen	300	1013	P12	50 - 70 - 90	50 - 60 - 70
		gehärtet und angelassen	400	1361	P13	50 - 70 - 90	50 - 60 - 70
	Nichtrostender Stahl	ferritisch / martensitisch, geglüht	200	675	P14	50 - 65 - 80	50 - 60 - 70
martensitisch, vergütet		330	1114	P15	50 - 65 - 80	50 - 60 - 70	
M	Nichtrostender Stahl	austenitisch, abgeschreckt	200	675	M1	70 - 95 - 120	70 - 80 - 90
		austenitisch, ausscheidungsgehärtet (PH)	300	1013	M2	40 - 65 - 90	40 - 55 - 65
		austenitisch-ferritisch, Duplex	230	778	M3	10 - 35 - 60	10 - 25 - 40
K	Temperguss	ferritisch	200	675	K1	70 - 110 - 150	70 - 90 - 110
		perritisch	260	867	K2	-	-
	Grauguss	niedrige Festigkeit	180	602	K3	-	-
		hohe Festigkeit / austenitisch	245	825	K4	80 - 100 - 120	80 - 90 - 100
	Gusseisen mit Kugelgraphit	ferritisch	155	518	K5	80 - 90 - 100	80 - 85 - 90
		perritisch	265	885	K6	80 - 90 - 100	80 - 85 - 90
GGV (CGI)		200	675	K7	70 - 110 - 150	70 - 90 - 110	
N	Aluminium-Knetlegierungen	nicht aushärtbar	30	-	N1	100 - 170 - 240	100 - 170 - 240
		aushärtbar, ausgehärtet	100	343	N2	80 - 125 - 170	80 - 125 - 170
	Aluminium-Gusslegierungen	≤ 12 % Si, nicht aushärtbar	75	260	N3	-	-
		≤ 12 % Si, aushärtbar, ausgehärtet	90	314	N4	-	-
		> 12 % Si, nicht aushärtbar	130	447	N5	-	-
	Magnesiumlegierungen		70	250	N6	-	-
	Kupfer und Kupferlegierungen (Bronze / Messing)	unlegiert, Elektrolytkupfer	100	343	N7	100 - 175 - 250	100 - 175 - 250
		Messing, Bronze, Rotguss	90	314	N8	80 - 140 - 200	80 - 140 - 200
		Cu-Legierung, kurzspanend	110	382	N9	100 - 175 - 250	100 - 175 - 250
		hochfest, Ampco	300	1013	N10	-	-
Nichtmetallische Werkstoffe	Thermoplaste (ohne abrasive Füllstoffe)	-	-	N11	-	-	
	Duroplaste (ohne abrasive Füllstoffe)	-	-	N12	-	-	
	Kunststoff glasfaserverstärkt GFRP	-	-	N13	-	-	
	Kunststoff kohlefaserverstärkt CFRP	-	-	N14	-	-	
	Kunststoff aramidfaserverstärkt AFRP	-	-	N15	-	-	
	Graphit (technisch)	80 Shore	-	N16	-	-	
S	Warmfeste Legierungen	Fe-Basis geglüht	200	675	S1	-	-
		ausgehärtet	280	943	S2	-	-
		geglüht	250	839	S3	-	-
		Ni- oder Co-Basis ausgehärtet	350	1177	S4	-	-
		gegossen	320	1076	S5	-	-
	Titanlegierungen	Reintitan	200	675	S6	-	-
		α- und β-Legierungen, ausgehärtet	375	1262	S7	-	-
		β-Legierungen	410	1396	S8	-	-
	Wolframlegierungen		300	1013	S9	-	-
	Molybdänlegierungen		300	1013	S10	-	-
H	Gehärteter Stahl	gehärtet und angelassen	50 HRC	-	H1	-	-
		gehärtet und angelassen	55 HRC	-	H2	-	-
		gehärtet und angelassen	60 HRC	-	H3	-	-
	Gehärtetes Gusseisen	gehärtet und angelassen	55 HRC	-	H4	-	-

Die Tabellenwerte sind Richtwerte.
Es kann notwendig sein, die Werte den jeweiligen Bearbeitungsumständen anzupassen.



Material group	Structure of the material groups and identification letters		Brinell hardness HB	Tensile strength Rm (N/mm ²)	Chipping group	Cutting speed V _c (m/min)		
						coated	uncoated	
						AP5020	AK1020	
P	Unalloyed steel	C ≤ 0.25 % annealed	125	428	P1	20 - 100 - 180	20 - 75 - 130	
		C > 0.25 ... ≤ 0.55 % annealed	190	639	P2	20 - 100 - 180	20 - 75 - 130	
		C > 0.25 ... ≤ 0.55 % hardened and tempered	210	708	P3	20 - 100 - 180	20 - 75 - 130	
		C > 0.55 % annealed	190	639	P4	20 - 100 - 180	20 - 75 - 130	
		C > 0.55 % hardened and tempered	300	1013	P5	20 - 100 - 180	20 - 75 - 130	
		Machining steel (short-chipping) tempered	220	745	P6	20 - 100 - 180	20 - 75 - 130	
	Low alloyed steel	annealed	175	591	P7	15 - 90 - 160	15 - 65 - 110	
		hardened and tempered	300	1013	P8	15 - 90 - 160	15 - 65 - 110	
		hardened and tempered	380	1282	P9	15 - 90 - 160	15 - 65 - 110	
		hardened and tempered	430	1477	P10	15 - 90 - 160	15 - 65 - 110	
	High alloyed steel and high alloyed tool steel	annealed	200	675	P11	20 - 70 - 120	20 - 55 - 85	
		hardened	300	1013	P12	20 - 70 - 120	20 - 55 - 85	
		hardened	400	1361	P13	20 - 70 - 120	20 - 55 - 85	
	Stainless steel	ferritic / martensitic, annealed	200	675	P14	20 - 55 - 90	20 - 40 - 60	
		martensitic, hardened and tempered	330	1114	P15	20 - 100 - 180	20 - 40 - 60	
M	Stainless steel	austenitic, chilled	200	675	M1	15 - 50 - 80	15 - 45 - 70	
		austenitic, precipitation-hardened (PH)	300	1013	M2	20 - 65 - 110	15 - 50 - 80	
		austenitic-ferritic, Duplex	230	778	M3	10 - 35 - 60	10 - 25 - 40	
K	Malleable cast iron	ferritic	200	675	K1	20 - 85 - 150	20 - 70 - 120	
		pearlitic	260	867	K2	20 - 85 - 150	20 - 70 - 120	
	Cast iron	low tensile strength	180	602	K3	20 - 90 - 160	20 - 65 - 110	
		high tensile strength / austenitic	245	825	K4	20 - 90 - 160	20 - 65 - 110	
	Cast iron with nodular graphite	ferritic	155	518	K5	20 - 85 - 150	20 - 65 - 110	
		pearlitic	265	885	K6	20 - 85 - 150	20 - 65 - 110	
	GGV (CGI)		200	675	K7	20 - 85 - 150	20 - 70 - 120	
N	Aluminium alloys long chipping	not heat treatable	30	-	N1	20 - 310 - 600	20 - 260 - 500	
		heat treatable, heat treated	100	343	N2	20 - 310 - 600	20 - 260 - 500	
	Casted aluminium alloys	≤ 12 % Si, not heat treatable	75	260	N3	20 - 310 - 600	20 - 260 - 500	
		≤ 12 % Si, aushärtbar, ausgehärtet	90	314	N4	20 - 310 - 600	20 - 260 - 500	
		> 12 % Si, not heat treatable	130	447	N5	20 - 310 - 600	20 - 260 - 500	
	Magnesium alloys		70	250	N6	-	-	
	Copper and copper alloys (Brass / Bronze)	Unalloyed, elektrolyte copper	100	343	N7	20 - 310 - 600	15 - 260 - 500	
		Brass, Bronze	90	314	N8	20 - 310 - 600	15 - 260 - 500	
		Cu-alloys, short-chipping	110	382	N9	20 - 310 - 600	15 - 260 - 500	
		High-tensile, Ampco	300	1013	N10	-	-	
Non-ferrous materials	Lead alloys (without abrasive filling material)	-	-	N11	-	-		
	Duroplastic (without abrasive filling material)	-	-	N12	-	-		
	Plastic glas fibre reinforced GFRP	-	-	N13	-	-		
	Plastic carbon fibre reinforced CFRP	-	-	N14	-	-		
	Plastic aramid fibre reinforced AFRP	-	-	N15	-	-		
	Graphite (tech.)	80 Shore	-	N16	-	-		
S	High temperature resistant alloys	Fe-Basis	annealed	200	675	S1	15 - 45 - 75	15 - 25 - 30
			heat treated	280	943	S2	15 - 45 - 75	15 - 25 - 30
		Ni- or Co-alloyed	annealed	250	839	S3	15 - 30 - 40	15 - 30 - 40
			heat treated	350	1177	S4	15 - 30 - 40	15 - 30 - 40
			casting	320	1076	S5	15 - 30 - 40	15 - 30 - 40
	Titanium alloys	Pure titan	200	675	S6	-	-	
		α- and β-alloys, heat treated	375	1262	S7	-	-	
	β-alloys	410	1396	S8	-	-		
	Wolfram alloys		300	1013	S9	-	-	
	Molybdän alloys		300	1013	S10	-	-	
H	Hardened steel	hardened	50 HRC	-	H1	-	-	
		hardened	55 HRC	-	H2	-	-	
		hardened	60 HRC	-	H3	-	-	
	Hardened cast iron	hardened	55 HRC	-	H4	-	-	

The recommended cutting data are only approximate values. It may be necessary to adjust them to each individual machining application.

Material group	Structure of the material groups and identification letters		Brinell hardness HB	Tensile strength Rm (N/mm ²)	Chipping group	Cutting speed V _c (m/min)		
						coated	uncoated	
						AP5020	AK1020	
P	Unalloyed steel	C ≤ 0.25 % annealed	125	428	P1	80 - 115 - 150	80 - 95 - 110	
		C > 0.25 ... ≤ 0.55 % annealed	190	639	P2	80 - 115 - 150	80 - 95 - 110	
		C > 0.25 ... ≤ 0.55 % hardened and tempered	210	708	P3	60 - 90 - 120	60 - 75 - 90	
		C > 0.55 % annealed	190	639	P4	80 - 115 - 150	80 - 95 - 110	
		C > 0.55 % hardened and tempered	300	1013	P5	60 - 90 - 120	60 - 75 - 90	
		Machining steel (short-chipping) tempered	220	745	P6	80 - 115 - 150	80 - 95 - 110	
	Low alloyed steel	annealed	175	591	P7	70 - 100 - 130	70 - 85 - 100	
		hardened and tempered	300	1013	P8	70 - 95 - 120	70 - 80 - 90	
		hardened and tempered	380	1282	P9	70 - 95 - 120	70 - 80 - 90	
		hardened and tempered	430	1477	P10	70 - 95 - 115	70 - 80 - 85	
	High alloyed steel and high alloyed tool steel	annealed	200	675	P11	60 - 85 - 110	60 - 70 - 80	
		hardened	300	1013	P12	50 - 70 - 90	50 - 60 - 70	
		hardened	400	1361	P13	50 - 70 - 90	50 - 60 - 70	
	Stainless steel	ferritic / martensitic, annealed	200	675	P14	50 - 65 - 80	50 - 60 - 70	
martensitic, hardened and tempered		330	1114	P15	50 - 65 - 80	50 - 60 - 70		
M	Stainless steel	austenitic, chilled	200	675	M1	70 - 95 - 120	70 - 80 - 90	
		austenitic, precipitation-hardened (PH)	300	1013	M2	40 - 65 - 90	40 - 55 - 65	
		austenitic-ferritic, Duplex	230	778	M3	10 - 35 - 60	10 - 25 - 40	
K	Malleable cast iron	ferritic	200	675	K1	70 - 110 - 150	70 - 90 - 110	
		pearlitic	260	867	K2	-	-	
	Cast iron	low tensile strength	180	602	K3	-	-	
		high tensile strength / austenitic	245	825	K4	80 - 100 - 120	80 - 90 - 100	
	Cast iron with nodular graphite	ferritic	155	518	K5	80 - 90 - 100	80 - 85 - 90	
		pearlitic	265	885	K6	80 - 90 - 100	80 - 85 - 90	
GGV (CGI)		200	675	K7	70 - 110 - 150	70 - 90 - 110		
N	Aluminium alloys long chipping	not heat treatable	30	-	N1	100 - 170 - 240	100 - 170 - 240	
		heat treatable, heat treated	100	343	N2	80 - 125 - 170	80 - 125 - 170	
	Casted aluminium alloys	≤ 12 % Si, not heat treatable	75	260	N3	-	-	
		≤ 12 % Si, aushärtbar, ausgehärtet	90	314	N4	-	-	
		> 12 % Si, not heat treatable	130	447	N5	-	-	
	Magnesium alloys		70	250	N6	-	-	
	Copper and copper alloys (Brass / Bronze)	Unalloyed, elektrolyte copper	100	343	N7	100 - 175 - 250	100 - 175 - 250	
		Brass, Bronze	90	314	N8	80 - 140 - 200	80 - 140 - 200	
		Cu-alloys, short-chipping	110	382	N9	100 - 175 - 250	100 - 175 - 250	
		High-tensile, Ampco	300	1013	N10	-	-	
	Non-ferrous materials	Lead alloys (without abrasive filling material)	-	-	N11	-	-	
Duroplastic (without abrasive filling material)		-	-	N12	-	-		
Plastic glas fibre reinforced GFRP		-	-	N13	-	-		
Plastic carbon fibre reinforced CFRP		-	-	N14	-	-		
Plastic aramid fibre reinforced AFRP		-	-	N15	-	-		
Graphite (tech.)			80 Shore	-	N16	-	-	
S	High temperature resistant alloys	Fe-Basis	annealed	200	675	S1	-	-
			heat treated	280	943	S2	-	-
		Ni- or Co-alloyed	annealed	250	839	S3	-	-
			heat treated	350	1177	S4	-	-
			casting	320	1076	S5	-	-
	Titanium alloys	Pure titan	200	675	S6	-	-	
		α- and β-alloys, heat treated	375	1262	S7	-	-	
		β-alloys	410	1396	S8	-	-	
	Wolfram alloys		300	1013	S9	-	-	
	Molybdän alloys		300	1013	S10	-	-	
H	Hardened steel	hardened	50 HRC	-	H1	-	-	
		hardened	55 HRC	-	H2	-	-	
		hardened	60 HRC	-	H3	-	-	
	Hardened cast iron	hardened	55 HRC	-	H4	-	-	

The recommended cutting data are only approximate values. It may be necessary to adjust them to each individual machining application.



Gruppo materiale	Struttura dei gruppi di materiali e lettere di riferimento		Durezza Brinell	Resistenza Rm (N/mm ²)	Gruppo di lavoro	Velocità di taglio V _c (m/min)	
						rivestito	non rivestito
						AP5020	AK1020
P	Acciai non legato	C ≤ 0,25 % ricotto	125	428	P1	20 - 100 - 180	20 - 75 - 130
		C > 0,25 ... ≤ 0,55 % ricotto	190	639	P2	20 - 100 - 180	20 - 75 - 130
		C > 0,25 ... ≤ 0,55 % bonificato	210	708	P3	20 - 100 - 180	20 - 75 - 130
		C > 0,55 % ricotto	190	639	P4	20 - 100 - 180	20 - 75 - 130
		C > 0,55 % bonificato	300	1013	P5	20 - 100 - 180	20 - 75 - 130
		Acciaio (truciolo corto) ricotto	220	745	P6	20 - 100 - 180	20 - 75 - 130
	Acciai debolmente legati	ricotto	175	591	P7	15 - 90 - 160	15 - 65 - 110
		bonificato	300	1013	P8	15 - 90 - 160	15 - 65 - 110
		bonificato	380	1282	P9	15 - 90 - 160	15 - 65 - 110
		bonificato	430	1477	P10	15 - 90 - 160	15 - 65 - 110
	Acciai fortemente legati e acciai da utensili	ricotto	200	675	P11	20 - 70 - 120	20 - 55 - 85
		temprato e rinvenuto	300	1013	P12	20 - 70 - 120	20 - 55 - 85
		temprato e rinvenuto	400	1361	P13	20 - 70 - 120	20 - 55 - 85
	Acciai inossidabili	ferritico / martensitico, ricotto	200	675	P14	20 - 55 - 90	20 - 40 - 60
		martensitico, bonificato	330	1114	P15	20 - 100 - 180	20 - 40 - 60
M	Acciai inossidabili	austenitico, trattato o temperato	200	675	M1	15 - 50 - 80	15 - 45 - 70
		austenitico, indurimento per precipitazione (PH)	300	1013	M2	20 - 65 - 110	15 - 50 - 80
		austenitico-ferritico, Duplex	230	778	M3	10 - 35 - 60	10 - 25 - 40
K	Ghisa temprata	ferritico	200	675	K1	20 - 85 - 150	20 - 70 - 120
		perlitica	260	867	K2	20 - 85 - 150	20 - 70 - 120
	Ghisa grigia	bassa resistenza	180	602	K3	20 - 90 - 160	20 - 65 - 110
		alta resistenza / austenitico	245	825	K4	20 - 90 - 160	20 - 65 - 110
	Ghisa sferoidale	ferritico	155	518	K5	20 - 85 - 150	20 - 65 - 110
		perlitica	265	885	K6	20 - 85 - 150	20 - 65 - 110
GGV (CGI)		200	675	K7	20 - 85 - 150	20 - 70 - 120	
N	Leghe di Alluminio stampato	non invecchiato	30	-	N1	20 - 310 - 600	20 - 260 - 500
		rinvenuto, invecchiato	100	343	N2	20 - 310 - 600	20 - 260 - 500
	Leghe di Alluminio da fusione	≤ 12 % Si, non invecchiato	75	260	N3	20 - 310 - 600	20 - 260 - 500
		≤ 12 % Si, rinvenuto, invecchiato	90	314	N4	20 - 310 - 600	20 - 260 - 500
		> 12 % Si, non invecchiato	130	447	N5	20 - 310 - 600	20 - 260 - 500
	Leghe di magnesio		70	250	N6	-	-
	Rame e Leghe di Rame (Bronzo / Ottone)	Non legati, Rame Elettrolitico	100	343	N7	20 - 310 - 600	15 - 260 - 500
		Ottone, Bronzo	90	314	N8	20 - 310 - 600	15 - 260 - 500
		Leghe Cu, truciolo corto	110	382	N9	20 - 310 - 600	15 - 260 - 500
		Alta resistenza, Ampco	300	1013	N10	-	-
Materiali non metallici	Leghe al piombo (senza materiale di riempimento abrasivo)	-	-	N11	-	-	
	Duroplastico (senza materiale di riempimento abrasivo)	-	-	N12	-	-	
	Plastica rinforzata in fibra di vetro GFRP	-	-	N13	-	-	
	Plastica rinforzata in fibra di carbonio CFRP	-	-	N14	-	-	
	Plastica rinforzata in fibra aramidica AFRP	-	-	N15	-	-	
	Grafite (tecnico)		80 Shore	-	N16	-	-
S	Leghe resistenti al calore	Base-Fe ricotto	200	675	S1	15 - 45 - 75	15 - 25 - 30
		Base-Fe invecchiato	280	943	S2	15 - 45 - 75	15 - 25 - 30
		Base Ni o Co ricotto	250	839	S3	15 - 30 - 40	15 - 30 - 40
		Base Ni o Co invecchiato	350	1177	S4	15 - 30 - 40	15 - 30 - 40
		Base Ni o Co da fusione	320	1076	S5	15 - 30 - 40	15 - 30 - 40
	Leghe di Titanio	Titanio puro	200	675	S6	-	-
		Leghe α e β, invecchiato	375	1262	S7	-	-
		Leghe β	410	1396	S8	-	-
	Leghe di tungsteno		300	1013	S9	-	-
	Leghe di molibdeno		300	1013	S10	-	-
H	Acciaio Temprato	temprato e rinvenuto	50 HRC	-	H1	-	-
		temprato e rinvenuto	55 HRC	-	H2	-	-
		temprato e rinvenuto	60 HRC	-	H3	-	-
	Ghisa Temprata	temprato e rinvenuto	55 HRC	-	H4	-	-

I dati indicati in tabella sono valori approssimati. Può essere necessario adattarli alle singole applicazioni di lavorazione.

Gruppo materiale	Struttura dei gruppi di materiali e lettere di riferimento		Durezza Brinell	Resistenza Rm (N/mm ²)	Gruppo di lavoro	Velocità di taglio V _c (m/min)	
						rivestito	non rivestito
						AP5020	AK1020
P	Acciai non legato	C ≤ 0,25 % ricotto	125	428	P1	80 - 115 - 150	80 - 95 - 110
		C > 0,25 ... ≤ 0,55 % ricotto	190	639	P2	80 - 115 - 150	80 - 95 - 110
		C > 0,25 ... ≤ 0,55 % bonificato	210	708	P3	60 - 90 - 120	60 - 75 - 90
		C > 0,55 % ricotto	190	639	P4	80 - 115 - 150	80 - 95 - 110
		C > 0,55 % bonificato	300	1013	P5	60 - 90 - 120	60 - 75 - 90
		Acciaio (truciolo corto) ricotto	220	745	P6	80 - 115 - 150	80 - 95 - 110
	Acciai debolmente legati	ricotto	175	591	P7	70 - 100 - 130	70 - 85 - 100
		bonificato	300	1013	P8	70 - 95 - 120	70 - 80 - 90
		bonificato	380	1282	P9	70 - 95 - 120	70 - 80 - 90
		bonificato	430	1477	P10	70 - 95 - 115	70 - 80 - 85
	Acciai fortemente legati e acciai da utensili	ricotto	200	675	P11	60 - 85 - 110	60 - 70 - 80
		temprato e rinvenuto	300	1013	P12	50 - 70 - 90	50 - 60 - 70
		temprato e rinvenuto	400	1361	P13	50 - 70 - 90	50 - 60 - 70
	Acciai inossidabili	ferritico / martensitico, ricotto	200	675	P14	50 - 65 - 80	50 - 60 - 70
martensitico, bonificato		330	1114	P15	50 - 65 - 80	50 - 60 - 70	
M	Acciai inossidabili	austenitico, trattato o temperato	200	675	M1	70 - 95 - 120	70 - 80 - 90
		austenitico, indurimento per precipitazione (PH)	300	1013	M2	40 - 65 - 90	40 - 55 - 65
		austenitico-ferritico, Duplex	230	778	M3	10 - 35 - 60	10 - 25 - 40
K	Ghisa temprata	ferritico	200	675	K1	70 - 110 - 150	70 - 90 - 110
		perlitica	260	867	K2	-	-
	Ghisa grigia	bassa resistenza	180	602	K3	-	-
		alta resistenza / austenitico	245	825	K4	80 - 100 - 120	80 - 90 - 100
	Ghisa sferoidale	ferritico	155	518	K5	80 - 90 - 100	80 - 85 - 90
		perlitica	265	885	K6	80 - 90 - 100	80 - 85 - 90
GGV (CGI)		200	675	K7	70 - 110 - 150	70 - 90 - 110	
N	Leghe di Alluminio stampato	non invecchiato	30	-	N1	100 - 170 - 240	100 - 170 - 240
		rinvenuto, invecchiato	100	343	N2	80 - 125 - 170	80 - 125 - 170
	Leghe di Alluminio da fusione	≤ 12 % Si, non invecchiato	75	260	N3	-	-
		≤ 12 % Si, rinvenuto, invecchiato	90	314	N4	-	-
		> 12 % Si, non invecchiato	130	447	N5	-	-
	Leghe di magnesio		70	250	N6	-	-
	Rame e Leghe di Rame (Bronzo / Ottone)	Non legati, Rame Elettrolitico	100	343	N7	100 - 175 - 250	100 - 175 - 250
		Ottone, Bronzo	90	314	N8	80 - 140 - 200	80 - 140 - 200
		Leghe Cu, truciolo corto	110	382	N9	100 - 175 - 250	100 - 175 - 250
		Alta resistenza, Ampco	300	1013	N10	-	-
Materiali non metallici	Leghe al piombo (senza materiale di riempimento abrasivo)	-	-	N11	-	-	
	Duroplastico (senza materiale di riempimento abrasivo)	-	-	N12	-	-	
	Plastica rinforzata in fibra di vetro GFRP	-	-	N13	-	-	
	Plastica rinforzata in fibra di carbonio CFRP	-	-	N14	-	-	
	Plastica rinforzata in fibra aramidica AFRP	-	-	N15	-	-	
	Grafite (tecnico)		80 Shore	-	N16	-	-
S	Leghe resistenti al calore	Base-Fe ricotto	200	675	S1	-	-
		Base-Fe invecchiato	280	943	S2	-	-
		Base Ni o Co ricotto	250	839	S3	-	-
		Base Ni o Co invecchiato	350	1177	S4	-	-
		Base Ni o Co da fusione	320	1076	S5	-	-
	Leghe di Titanio	Titanio puro	200	675	S6	-	-
		Leghe α e β, invecchiato	375	1262	S7	-	-
		Leghe β	410	1396	S8	-	-
	Leghe di tungsteno		300	1013	S9	-	-
	Leghe di molibdeno		300	1013	S10	-	-
H	Acciaio Temprato	temprato e rinvenuto	50 HRC	-	H1	-	-
		temprato e rinvenuto	55 HRC	-	H2	-	-
		temprato e rinvenuto	60 HRC	-	H3	-	-
	Ghisa Temprata	temprato e rinvenuto	55 HRC	-	H4	-	-

I dati indicati in tabella sono valori approssimati. Può essere necessario adattarli alle singole applicazioni di lavorazione.



Schnittdatenrichtwerte Gewindedrehen – Anzahl der Durchgänge

Recommended cutting data – Threading – Number of passes

Parametri di taglio suggeriti – Filettatura – Numero di passate

Steigung Pitch Passo		Anzahl der Schnitte Number of passes Numero di passate					
(mm)	Gang/Zoll Pitch/Inch Filetti/Pollice	Stahl Festigkeit (N/mm ²) Steel strength (N/mm ²) Acciaio resistenza (N/mm ²)			Rostfrei Stainless Acciaio inossidabile	Guss Cast Ghisa	Aluminium Aluminium Alluminio
		400–700	700–1.000	> 1.000			
0,8	32	8	9	10	10	9	8
1	24	10	11	12	12	12	10
1,25	20–19	12	14	15	15	14	12
1,5	16	15	17	18	18	17	15
1,75	14	17	19	21	21	18	17
2	12	19	22	25	25	20	18
2,5	10	22	26	31	31	22	20
3,0–3,5	8	28	32	38	38	24	22

Die hier aufgeführten Werte sind allgemeine Empfehlungen für die Anzahl der Durchgänge bei der Bearbeitung von normalen Stahl- und NE-Werkstoffen. Bei harten Werkstoffen ist die Schnitttiefe zu reduzieren und die Anzahl der Schnitte zu erhöhen.

Bei Plattenbruch ist die Anzahl der Durchgänge zu erhöhen, bei hohem Verschleiß zu verringern.

HINWEIS: Der Spanquerschnitt sollte bei jedem Durchgang gleich groß sein, das heißt mit zunehmender Schnitttiefe ist die Zustellung zu reduzieren, um konstante Schnittkräfte zu erreichen.

The above mentioned data are general recommendations for machining steel and non-ferrous materials. With hard materials we recommend to reduce cutting speed and increase number of passes.

By cutting edge breakage we suggest to increase number of passes, by edge wear reduce the number of passes.

REMARK: The chip thickness should be constant at every pass, so with more cutting depth reduce the in-feed in order to obtain constant cutting forces.

I valori sopra indicati sono per materiali non trattati termicamente. Per materiali più duri ridurre le velocità di taglio e aumentare il numero di passate.

In caso di scheggiature del tagliente si suggerisce di aumentare il numero delle passate, in caso di usura invece si suggerisce di ridurre il numero di passate.

NOTA: Lo spessore truciolo deve essere costante ad ogni passata. Per avere una sezione truciolo ed una forza di taglio costante durante la lavorazione adattare avanzamenti e profondità di passate.

SIM – Bohrstangen – Vorschubbereiche

SIM – Boring bars – Feed rate

SIM – Baren – Avanzamento nel pieno

8

f [mm/U] 0,01–0,05

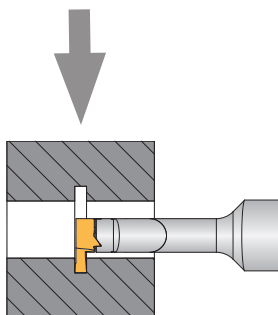

f [mm/U] 0,03–0,10

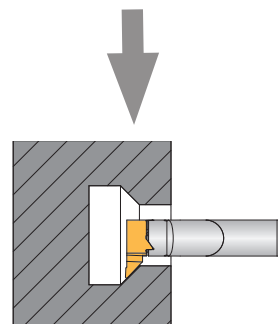

Gewindedrehen / Threading / Filettatura



Radiale Zustellung
Einfache und gebräuchlichste Zustellung senkrecht zur Drehachse. Die Zerspaltung erfolgt auf beiden Zahnflanken, wodurch ein gleichmäßiger Verschleiß gewährleistet ist. Empfohlen bei kleinen Steigungen bis ca. 2 mm. Bevorzugt für kurzspanende Werkstoffe und zur Kaltverfestigung neigende sowie nichtrostende Stähle.

Radial infeed
Radial infeed is the simplest and quickest method. The feed is perpendicular to the turning axis and both flanks of the insert perform the cutting operation. Radial infeed is recommended when the pitch is smaller than 2 mm, for material with short chips, for workhardened materials and stainless steel.

Incremento radiale
L'incremento radiale è il metodo più semplice e veloce. L'incremento è perpendicolare all'asse di rotazione ed entrambe i taglienti lavorano contemporaneamente. Suggesto per passi inferiori ai 2 mm, per materiali a truciolo corto, per materiali temprati ed acciai inossidabili.



Modifizierte Flankenstellung
Zustellung unter einem Winkel von 3°–5° zur Flanke des Gewindes. Bevorzugt bei NC-Maschinen. Gute Spankontrolle, daher besonders für Innengewinde und langspanende Werkstoffe geeignet. Bei größeren Steigungen ab 2 mm.

Flank infeed
Infeed at an angle of 3°–5° to the flank of the thread. Mainly used on NC-machines. Excellent chip control, therefore very suitable for internal threads and long chipping materials. Pitches greater than 2 mm.

Incremento sul fianco
L'incremento avviene ad un angolo di 3°–5° dal fianco filetto. Utilizzato principalmente su macchine a controllo numerico. Eccellente controllo truciolo, quindi valido per tutti i materiali a truciolo lungo. Per passi superiori ai 2 mm.



Wechselseitige Zustellung
Wechselseitige Zustellung entlang beider Flanken. Hohe Standzeiten durch gleichmäßigen Flankenverschleiß an beiden Schneidkanten. Besonders bei großen Steigungen ab 4 mm auf NC-Maschinen mit spezieller Programmierung.

Alternating flank infeed
Use of alternate flank infeed is recommended especially in large pitches and for long chipping materials. This method divides the work equally on both flanks, resulting in equal wear on both edges. Alternate flank infeed requires more complicated programming and is not available on all lathes.

Incremento alternato
L'utilizzo dell'incremento alternato è suggerito per materiali a truciolo lungo e per filettature molto larghe. Questo sistema suddivide in modo uguale le passate sui due lati del tagliente portando ad una usura costante e regolare dell'inserto. L'incremento alternato prevede una programmazione del controllo più complessa.

Berechnung des Steigungswinkels β

Calculation of helix angle β
Calcolo dell'angolo d'elica β

$$\beta = \frac{P \text{ [mm]}}{D \text{ [mm]}} \times 18,23$$

Am Beispiel Innengewinde M10, Steigung 1,5 mm:

Example internal thread M10. Pitch 1.5 mm:

Esempio Filettatura interna M10, Passo 1,5 mm:

$$\beta = \frac{1,5 \text{ mm}}{9,03 \text{ mm}} \times 18,23 = 3,03^\circ$$

Steigungswinkel
helix angle
Angolo elica filetto

β = Steigungswinkel (Grad)
Helix angle (°)
Angolo d'elica filettatura (gradi)

P = Steigung (mm)
Pitch (mm)
Passo (mm)

D = Flankendurchmesser (mm)
Edge diameter (mm)
Diametro preforo (mm)

ISO – Innengewinde

ISO – Internal thread

ISO – Filettatura interna

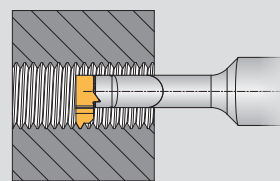

Halter und Schneideinsätze in Rechtsausführung

Holder and inserts in Right-hand version

Utensile ed inserti in versione destra

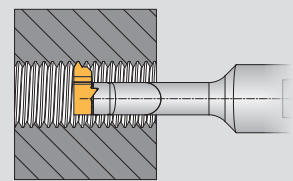

Halter und Schneideinsätze in Linksausführung

Holder and inserts in Left-hand version

Utensile ed inserti in versione sinistra

Montagehinweis

Assembly guide

Schema di montaggio

Linke Bohrstange Linker Schneideinsatz

Left boring bar
Left insert

Bareno sinistro
Inserto sinistro



Rechte Bohrstange Rechter Schneideinsatz

Right boring bar
Right insert

Bareni destro
Inserto destro



Die 3-Punkt-Auflage garantiert eine exakte Wiederholgenauigkeit der Positionierung des Schneidkopfes zur Spitzenhöhe. Trotzdem ist immer auf die Spitzenhöhe zu achten, denn Abweichungen können besonders bei der Bearbeitung kleinster Durchmesser Probleme bereiten.

The 3-point location ensures accurate repeatability of the cutting edge height. However always be aware of the edge height. When machining small components small differences can cause big problems.

Il sistema di accoppiamento a 3 Punti assicura un accurato riposizionamento dell'inserto garantendo la ripetibilità di posizionamento dell'altezza tagliente. Prestare comunque massima attenzione specialmente su piccoli diametri in quanto una variazione di altezza può generare problematiche inaspettate.

Tipps:

- Bitte wählen Sie schmale Schneidkanten, damit der Span geschmeidig bleibt und am Werkzeug vorbei aus der Bohrung fließen kann.
- Um Spänestau zu vermeiden empfiehlt sich stufenförmig oder mit Schnittunterbrechung zu stechen.
- Empfohlener Kühlmitteldruck = 5 bar.
- Beim Wechseln des Schneidkopfes bitte die Schnittstelle mit Pressluft reinigen.

Suggestions:

- Always select smallest possible insert width, thereby the swarf remains flexible and evacuates the bore easier. To avoid swarf clogging we recommend grooving in steps or inserting a swarf release cut.
- Recommended coolant pressure = 5 bar.
- Clean insert pocket with compressed air when changing the insert.

Suggerimenti:

- Scegliere sempre la larghezza di taglio minore al fine di ridurre le forze di taglio e con un truciolo piccolo aiutare l'evacuazione dal foro. Si raccomanda anche di prevedere eventuali stacchi per forzare la rottura del truciolo.
- Pressione del refrigerante suggerita: 5 bar.
- Pulire accuratamente la sede durante la sostituzione inserto.

Praxisbeispiele / Solutions / Esempi

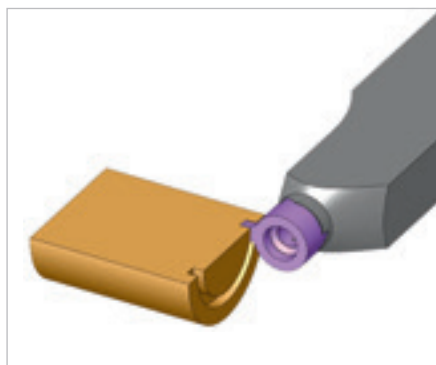

Sonder-Halter Spezielle Ausführung zur Axialbearbeitung.

Special holder
Special design for face grooving.

Adattatore speciale
Utensile speciale per gole frontali.



Sonder-Schneideinsatz CBN-bestückt. Speziell zum Hartdrehen.

Special insert
CBN brazed especially for hard turning.

Inserto speciale
Inserto speciale con riporto di CBN per materiali temprati.



9

Direktaufnahmen

Flange mounted holders

Attacchi base

Maschinen angepasste Spanneinheiten

Machine specific units

Adattatori per macchine specifiche

- Systemvorstellung
- Werkzeugauswahl
- KMH-Werkzeugaufnahmen
- Abstechhalter
- Direktaufnahmen
- Ersatzteile und Zubehör
- Anwendungshinweise

- Introduction
- Tool shank options
- KMH holders
- Part-off holders
- Flange mounted holders
- Spare parts and accessories
- Application reference

- Caratteristiche del sistema **446 – 448**
- Tipologie di corpo utensile **449 – 457**
- Adattatori KMH **458 – 477**
- Ricambi e accessori **478 – 515**
- Attacchi base **516 – 575**
- Ricambi e accessori **576**
- Suggerimenti tecnici **581 – 601**

Abstechhalter und Direktaufnahmen

Part-off holders and flange mounted holders

Adattatori di troncatura e attacchi base

Einbaulage Halter

Holder assembly

Montaggio adattatore



Einbaulage Halter – Überkopf

Holder assembly – upside down

Montaggio adattatore – rovesciato



Systemvorstellung

Speziell angepasste Direktaufnahmen zur Aufnahme von Monoblockhaltern, Abstechmodulen, Abstechklingen (SA-Stechnsystem) und Monoblockhaltern (SE). Die modularen Aufnahmen können normal und Überkopf montiert werden. Sie sind kompatibel für den Abstechbereich 20 bis 140 mm und für die Stechbreiten 1,5 bis 6 mm. Alle Aufnahmen verfügen über innere Kühlmittelzuführung (zum Teil auch für ACS-Module geeignet).

Introduction

Machine specific flange mounted holders for use with SA part-off modules, blades, monoblock holders, and monoblock holders SE. The modular holders can be mounted either normal or upside down. They are suitable for part-off range from 20 to 140 mm and for width from 1.5 to 6 mm. All holders are equipped with through tool coolant facility (partly also suitable with the ACS-Modules).

Descrizione

Corpi utensili del sistema di troncatura AR-NO®-SA per montaggio diretto a torretta. Gli adattatori sono registrabili ed invertibili per un utilizzo in entrambe i sensi di rotazione del mandrino. E' possibile montare moduli da taglio da 1,5 a 6,0 mm e per diametri da 20 a 140 mm. Tutti gli adattatori prevedono il passaggio interno del refrigerante (alcuni predisposti anche per sistema ACS ARNO-Cooling-System).

Fakten

Abstechhalter und Direktaufnahmen:

- höheneinstellbar
 - mit Innenkühlung und ACS2
 - modular aufgebaut für Schnittstelle:
 - KMH
 - VDI
 - Polygonschaft ISO 26623-1 – PSC...
 - BMT
 - Biglia
 - Daewoo/Doosan
 - Hardinge
 - Index/Traub
 - Mazak
 - Miyano
 - Mori Seiki
 - Marata
 - Nakamura
 - Göltensbodt
- und viele weitere

Features

Part-off holders and flange mounted holders:

- Height adjustable
 - With through tool coolant, ACS2
 - Modular holders with
 - KMH
 - VDI
 - Polygon-Shank ISO 26623-1 – PSC...
 - BMT
 - Biglia
 - Daewoo/Doosan
 - Hardinge
 - Index/Traub
 - Mazak
 - Miyano
 - Mori Seiki
 - Marata
 - Nakamura
 - Göltensbodt
- and many more

Caratteristiche

Adattatori di troncatura e attacchi base:

- Altezza registrabile
 - Con sistema refrigerante interno ACS2
 - Sistema modulare per attacco torretta:
 - KMH
 - VDI
 - Attacco poligonale ISO 26623-1 – PSC...
 - BMT
 - Biglia
 - Daewoo/Doosan
 - Hardinge
 - Index/Traub
 - Mazak
 - Miyano
 - Mori Seiki
 - Marata
 - Nakamura
 - Göltensbodt
- e molti altri

ACS – ARNO-Cooling-System / ARNO-Cooling-System / ARNO-Cooling-System

Die neuen SA-Module verfügen über eine patentierte, neue Technik der Kühlmittelzufuhr. Dabei erfolgt die Kühlung durch den Plattensitz und trifft direkt auf die Schnittzone. Der Kühlungsstrahl verursacht so eine Unterspülung des Spanes.

The new SA-Modules introduce a patented new system for coolant. The coolant flows through the blade to the insert seating and therefore goes straight to the cutting area. From the coolant hole the pressure flows under the swarf and thereby offering the best machining conditions.

L'innovativo sistema di troncatura brevettato ACS ARNO-Cooling-System permette al refrigerante di raggiungere il punto di taglio direttamente lungo la superficie dell'inserto oppure anche dalla parte inferiore alla zona di taglio raggiungendo il punto di massimo sviluppo di calore.

Vorteile der Unterspülung:

- Geführter Kühlmittelstrahl
- Sehr gute Kühl- und Spülwirkung
- Reduzierung von Aufbauschneidenbildung
- Kontrollierter Spanbruch
- Bessere Oberflächenqualität
- Höhere V_c und Vorschübe möglich
- Erhöhung der Produktivität

Key benefits of blasting up the swarf:

- Controlled coolant stream
- Best cooling and drilling fluid circulation
- Reduced building-up edge and cutting edge breakages
- Controlled chip breaking
- Better surface quality
- Higher V_c and feed rates possible
- Higher productivity

Vantaggi del sistema:

- Liquido di raffreddamento a getto direzionato
- Ottimo raffreddamento del punto di taglio
- Riduzione del tagliante di riporto
- Miglior rottura del truciolo
- Migliore qualità superficiale
- Maggiore velocità di avanzamento e di taglio
- Aumento della produttività

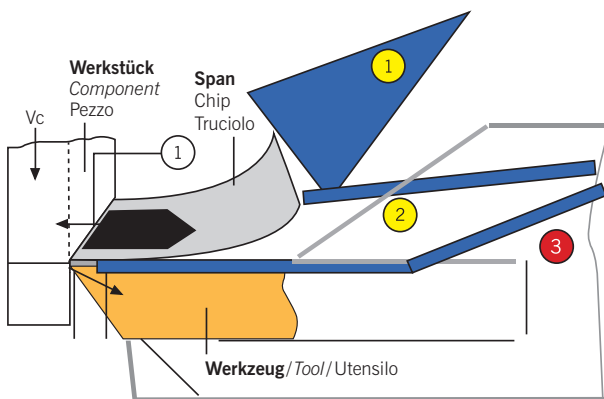

- 1 „Externe Kühlung“ über Spritzdüse / External coolant from coolant jet / Refrigerazione "estesa" dei sistemi tradizionali (su truciolo)
- 2 „Interne Kühlung“ über Halter oder Spannpratze / Through tool coolant / Refrigerazione direzionata tramite adduzioni interne classiche (su truciolo)
- 3 Neue „ACS-Kühlung“ direkt durch den Plattensitz / New ACS-coolant through the insert seat / Nuovo ACS ARNO-Cooling-System direttamente sul filo tagliente

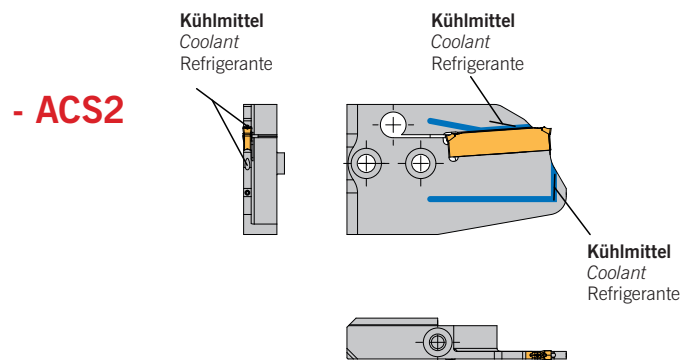
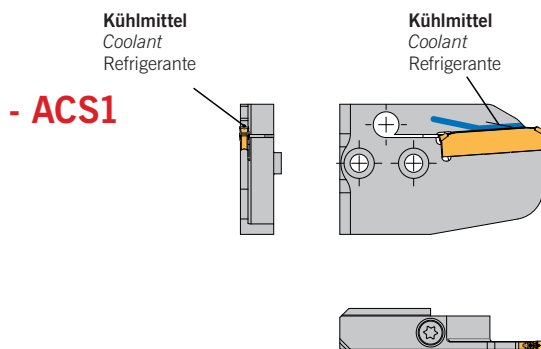

Linke Ausführung abgebildet
Left-hand execution shown
Versione sinistra in figura



KMH-Werkzeugaufnahmen / KMH holder / Adattatori KMH

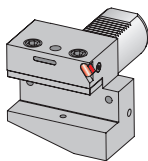

KMH-Werkzeugaufnahmen – Form B1 – kurz

KMH holders – Form B1 - short
Adattatori KMH – Forma B1 - corta

Seite/Page/Pagina **458**

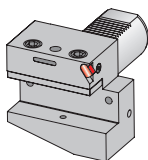

KMH-Werkzeugaufnahmen für Monoblockhalter ACS..-UN – Form B1 – kurz mit Innenkühlung

KMH holders for monoblock holders ACS..-UN – Form B1 - short with internal coolant
Adattatori KMH per utensili monoblocco ACS..-UN – Forma B1 - corta con refrigerazione interna

Seite/Page/Pagina **459**

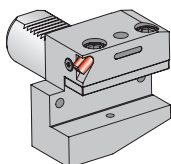

KMH-Werkzeugaufnahmen – Form B2 – kurz

KMH holders – Form B2 - short
Adattatori KMH – Forma B2 - corta

Seite/Page/Pagina **460**

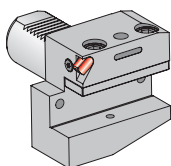

KMH-Werkzeugaufnahmen für Monoblockhalter ACS..-UN – Form B2 – kurz mit Innenkühlung

KMH holders for monoblock holders ACS..-UN – Form B2 - short with internal coolant
Adattatori KMH per utensili monoblocco ACS..-UN – Forma B2 - corta con refrigerazione interna

Seite/Page/Pagina **461**

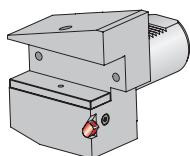

KMH-Werkzeugaufnahmen – Form B3 – Überkopf – kurz

KMH holders – Form B3 - Overhead - short
Adattatori KMH – Forma B3 - Invertito - corta

Seite/Page/Pagina **462**

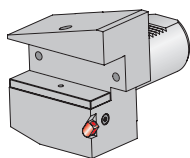

KMH-Werkzeugaufnahmen für Monoblockhalter ACS..-UN – Form B3 – Überkopf – kurz mit Innenkühlung

KMH holders for monoblock holders ACS..-UN – Form B3 - Overhead - short with internal coolant
Adattatori KMH per utensili monoblocco ACS..-UN –
Forma B3 - Invertito - corta con refrigerazione interna

Seite/Page/Pagina **463**

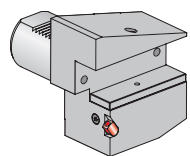

KMH-Werkzeugaufnahmen – Form B4 – Überkopf – kurz

KMH holders – Form B4 - Overhead - short
Adattatori KMH – Forma B4 - Invertito - corta

Seite/Page/Pagina **464**

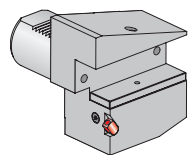

KMH-Werkzeugaufnahmen für Monoblockhalter ACS..-UN – Form B4 – Überkopf – kurz mit Innenkühlung

KMH holders for monoblock holders ACS..-UN – Form B4 - Overhead - short with internal coolant
Adattatori KMH per utensili monoblocco ACS..-UN –
Forma B4 - Invertito - corta con refrigerazione interna

Seite/Page/Pagina **465**

KMH-Werkzeugaufnahmen / KMH holder / Adattatori KMH

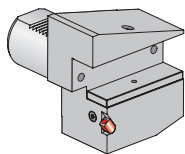

KMH-Werkzeugaufnahmen – Form B5 – lang

KMH holders – Form B5 - long
Adattatori KMH – Forma B5 - lunga

Seite/Page/Pagina **466**

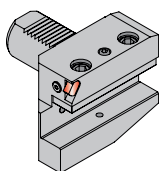

KMH-Werkzeugaufnahmen – Form B6 – lang

KMH holders – Form B6 - long
Adattatori KMH – Forma B6 - lunga

Seite/Page/Pagina **467**

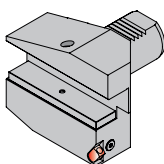

KMH-Werkzeugaufnahmen – Form B7 – Überkopf – lang

KMH holders – Form B7 - Overhead - long
Adattatori KMH – Forma B7 - Invertito - lunga

Seite/Page/Pagina **468**

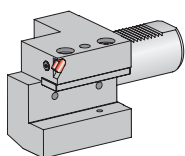

KMH-Werkzeugaufnahmen – Form C1

KMH holders – Form C1
Adattatori KMH – Forma C1

Seite/Page/Pagina **470**

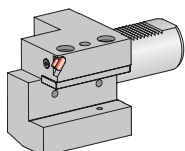

KMH-Werkzeugaufnahmen für Monoblockhalter ACS..-UN – Form C1 - mit Innenkühlung

KMH holders for monoblock holders ACS..-UN – Form C1 - with internal coolant
Adattatori KMH per utensili monoblocco ACS..-UN – Forma C1 - con refrigerazione interna

Seite/Page/Pagina **471**

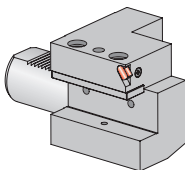

KMH-Werkzeugaufnahmen – Form C2

KMH holders – Form C2
Adattatori KMH – Forma C2

Seite/Page/Pagina **472**

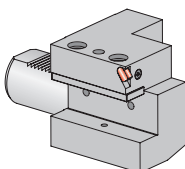

KMH-Werkzeugaufnahmen für Monoblockhalter ACS..-UN – Form C2 - mit Innenkühlung

KMH holders for monoblock holders ACS..-UN – Form C2 - with internal coolant
Adattatori KMH per utensili monoblocco ACS..-UN – Forma C2 - con refrigerazione interna

Seite/Page/Pagina **473**

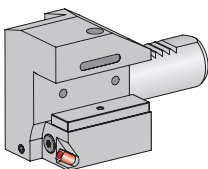

KMH-Werkzeugaufnahmen – Form C3 – Überkopf

KMH holders – Form C3 - Overhead
Adattatori KMH – Forma C3 - Invertito

Seite/Page/Pagina **474**

KMH-Werkzeugaufnahmen / KMH holder / Adattatori KMH

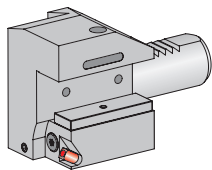

KMH-Werkzeugaufnahmen für Monoblockhalter ACS..-UN –

Form C3 – Überkopf mit Innenkühlung

KMH holders for monoblock holders ACS..-UN – Form C3 - Overhead with internal coolant

Adattatori KMH per utensili monoblocco ACS..-UN –

Forma C3 - Invertito con refrigerazione interna

Seite/Page/Pagina **475**

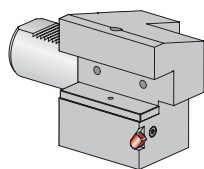

KMH-Werkzeugaufnahmen – Form C4 – Überkopf

KMH holders – Form C4 - Overhead

Adattatori KMH – Forma C4 - Invertito

Seite/Page/Pagina **476**

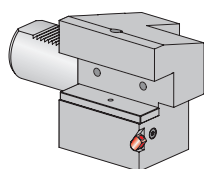

KMH-Werkzeugaufnahmen für Monoblockhalter ACS..-UN –

Form C4 – Überkopf mit Innenkühlung

KMH holders for monoblock holders ACS..-UN – Form C4 - Overhead with internal coolant

Adattatori KMH per utensili monoblocco ACS..-UN –

Forma C4 - Invertito con refrigerazione interna

Seite/Page/Pagina **477**

Abstechhalter / Part-off-holders / Adattatori di troncatura



Abstechhalter - MSA – VDI25 - mit Innenkühlung

Part-off-holders - MSA – VDI25 - with internal coolant

Adattatori di troncatura - MSA – VDI25 - con refrigerazione interna

Seite/Page/Pagina **478**



Abstechhalter - MSA – VDI25 - mit Innenkühlung

Part-off-holders - MSA – VDI25 - with internal coolant

Adattatori di troncatura - MSA – VDI25 - con refrigerazione interna

Seite/Page/Pagina **480**



Abstechhalter - MSA – VDI25 - mit Innenkühlung und ACS

Part-off-holders - MSA – VDI25 - with internal coolant and ACS

Adattatori di troncatura - MSA – VDI25 - con refrigerazione interna e ACS

Seite/Page/Pagina **482**

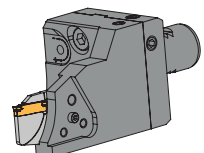

Abstechhalter - MSA-I.. – VDI25 - mit Innenkühlung und ACS

Part-off-holders - MSA-I.. – VDI25 - mit Innenkühlung und ACS

Adattatori di troncatura - MSA-I.. – VDI25 - mit Innenkühlung und ACS

Seite/Page/Pagina **484**

Abstechhalter / Part-off-holders / Adattatori di troncatura



Abstechhalter - MSA – VDI25 - mit Innenkühlung, ACS und W-Verzahnung

Part-off-holders - MSA – VDI25 - with internal coolant, ACS and W-notch

Adattatori di troncatura - MSA – VDI25 - con refrigerazione interna, ACS e piano tipo W

Seite/Page/Pagina **486**



Abstechhalter - MSA – VDI25 - mit Innenkühlung, ACS und W-Verzahnung

Part-off-holders - MSA – VDI25 - with internal coolant, ACS and W-notch

Adattatori di troncatura - MSA – VDI25 - con refrigerazione interna, ACS e piano tipo W

Seite/Page/Pagina **488**



Abstechhalter - MSA – VDI30 - mit Innenkühlung

Part-off-holders - MSA – VDI30 - with internal coolant

Adattatori di troncatura - MSA - VDI30 - con refrigerazione interna

Seite/Page/Pagina **490**



Abstechhalter - MSA – VDI30 - mit Innenkühlung und ACS

Part-off-holders - MSA – VDI30 - with internal coolant and ACS

Adattatori di troncatura - MSA - VDI30 - con refrigerazione interna e ACS

Seite/Page/Pagina **492**



Abstechhalter - MSA – VDI30 - mit Innenkühlung und ACS

Part-off-holders - MSA – VDI30 - with internal coolant and ACS

Adattatori di troncatura - MSA - VDI30 - con refrigerazione interna e ACS

Seite/Page/Pagina **494**



Abstechhalter - KSA – VDI30 - mit Innenkühlung und ACS für KSA-Steckklingen

Part-off-holders - KSA – VDI30 - with internal coolant and ACS for KSA blades

Adattatori di troncatura - KSA - VDI30 - con refrigerazione interna e ACS per lame KSA

Seite/Page/Pagina **496**



Abstechhalter - MSA – VDI30 - mit Innenkühlung, ACS und W-Verzahnung

Part-off-holders - MSA – VDI30 - with internal coolant, ACS and W-notch

Adattatori di troncatura - MSA – VDI30 - con refrigerazione interna, ACS e piano tipo W

Seite/Page/Pagina **498**



Abstechhalter - MSA – VDI40 - mit Innenkühlung

Part-off-holders - MSA – VDI40 - with internal coolant

Adattatori di troncatura - MSA - VDI40 - con refrigerazione interna

Seite/Page/Pagina **500**

Abstechhalter / Part-off-holders / Adattatori di troncatura



Abstechhalter - MSA – VDI40 - mit Innenkühlung

Part-off-holders - MSA – VDI40 - with internal coolant

Adattatori di troncatura - MSA - VDI40 - con refrigerazione interna

Seite/Page/Pagina **502**



Abstechhalter - MSA – VDI40 - mit Innenkühlung und ACS

Part-off-holders - MSA – VDI40 - with internal coolant and ACS

Adattatori di troncatura - MSA - VDI40 - con refrigerazione interna e ACS

Seite/Page/Pagina **504**



Abstechhalter - MSA – VDI50 - mit Innenkühlung und ACS

Part-off-holders - MSA – VDI50 - with internal coolant and ACS

Adattatori di troncatura - MSA - VDI50 - con refrigerazione interna e ACS

Seite/Page/Pagina **506**

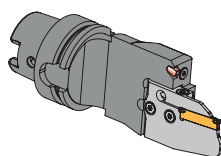

Abstechhalter - MSA – HSK-T63 - mit Innenkühlung und ACS

Part-off-holders - MSA – HSK-T63 - with internal coolant and ACS

Adattatori di troncatura - MSA - HSK-T63 - con refrigerazione interna e ACS

Seite/Page/Pagina **508**

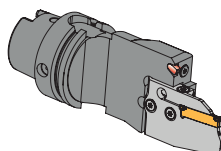

Abstechhalter - MSA – ST-HSK-T63 (ST-Stama) - mit Innenkühlung und ACS

Part-off-holders - MSA – ST-HSK-T63 (ST-Stama) - with internal coolant and ACS

Adattatori di troncatura - MSA - ST-HSK-T63 (ST-Stama) - con refrigerazione interna e ACS

Seite/Page/Pagina **510**



Abstechhalter - MSA - Polygonschaft – PSC40/PSC50/PSC63 - mit Innenkühlung und ACS

Part-off-holders - MSA - Polygon-Shank – PSC40/PSC50/PSC63 - with internal coolant and ACS

Adattatori di troncatura MSA - Attacco poligonale – PSC40/PSC50/PSC63 - con refrigerazione interna e ACS

Seite/Page/Pagina **512**

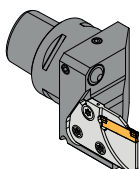

Abstechhalter - MSA-I - Polygonschaft – PSC40 - mit Innenkühlung und ACS

Part-off-holders - MSA-I - Polygon-Shank – PSC40 - with internal coolant and ACS

Adattatori di troncatura MSA-I - Attacco poligonale – PSC40 - con refrigerazione interna e ACS

Seite/Page/Pagina **514**

Maschinenspezifische Direktaufnahmen / Machine specific flange mounted holders / Adattatori specifici per attacchi torretta dedicati



Abstechhalter-MSA - Biglia – HBSA - mit Innenkühlung und ACS

Part-off-holders MSA - Biglia – HBSA - with internal coolant and ACS

Adattatori di troncatura MSA - Biglia – HBSA - con refrigerazione interna e ACS

Seite/Page/Pagina **516**



Abstechhalter-MSA - Biglia – HBSA - mit Innenkühlung und ACS

Part-off-holders MSA - Biglia – HBSA - with internal coolant and ACS

Adattatori di troncatura MSA - Biglia – HBSA - con refrigerazione interna e ACS

Seite/Page/Pagina **518**

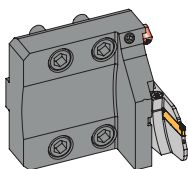

Abstechhalter-MSA - CMZ – HCMZ - mit Innenkühlung und ACS

Part-off-holders MSA - CMZ – HCMZ - with internal coolant and ACS

Adattatori di troncatura MSA - CMZ - HCMZ - con refrigerazione interna e ACS

Seite/Page/Pagina **520**



Abstechhalter-MSA - Daewoo / Doosan – BMT - mit Innenkühlung und ACS

Part-off-holders MSA - Daewoo / Doosan – BMT - with internal coolant and ACS

Adattatori di troncatura MSA - Daewoo / Doosan - BMT - con refrigerazione interna e ACS

Seite/Page/Pagina **522**



Abstechhalter-MSA - Daewoo / Doosan – BMT - mit Innenkühlung und ACS

Part-off-holders MSA - Daewoo / Doosan – BMT - with internal coolant and ACS

Adattatori di troncatura MSA - Daewoo / Doosan - BMT - con refrigerazione interna e ACS

Seite/Page/Pagina **524**



Abstechhalter-MSA - Daewoo / Doosan – HDD - mit Innenkühlung und ACS

Part-off-holders MSA - Daewoo / Doosan – HDD - with internal coolant and ACS

Adattatori di troncatura MSA - Daewoo / Doosan - HDD - con refrigerazione interna e ACS

Seite/Page/Pagina **526**

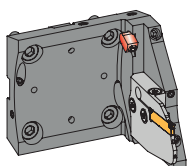

Abstechhalter-MSA - Daewoo / Doosan – BMT - mit Innenkühlung und ACS

Part-off-holders MSA - Daewoo / Doosan – BMT - with internal coolant and ACS

Adattatori di troncatura MSA - Daewoo / Doosan - BMT - con refrigerazione interna e ACS

Seite/Page/Pagina **528**



Abstechhalter-MSA - Hardinge – HHAR - mit ACS

Part-off-holders MSA - Hardinge – HHAR - with ACS

Adattatori di troncatura MSA - Hardinge - HHAR - con ACS

Seite/Page/Pagina **530**

Maschinenspezifische Direktaufnahmen / Machine specific flange mounted holders / Adattatori specifici per attacchi torretta dedicati



Abstechhalter - MSA-I - Index – HABC.. - mit Innenkühlung und ACS

Part-off-holders MSA-I - Index – HABC.. - with internal coolant and ACS

Adattatori di troncatura MSA-I - Index - HABC.. - con refrigerazione interna e ACS

Seite/Page/Pagina **532**



Abstechhalter-MSA - Index - Traub – HTR45 - mit Innenkühlung

Part-off-holders MSA - Index - Traub – HTR45 - with internal coolant

Adattatori di troncatura MSA - Index - Traub - HTR45 - con refrigerazione interna

Seite/Page/Pagina **534**



Abstechhalter-MSA-I - Index - Traub – HTR45 - mit Innenkühlung

Part-off-holders MSA-I - Index - Traub – HTR45 - with internal coolant

Adattatori di troncatura MSA-I - Index - Traub - HTR45 - con refrigerazione interna

Seite/Page/Pagina **536**



Abstechhalter-KSA - Index - Traub – HTR45 - mit Innenkühlung

Part-off-holders KSA - Index - Traub – HTR45 - with internal coolant

Adattatori di troncatura KSA - Index - Traub - HTR45 - con refrigerazione interna

Seite/Page/Pagina **538**

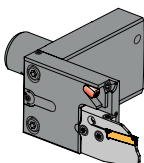

Abstechhalter-MSA - Mazak – HMAZ - mit Innenkühlung und ACS

Part-off-holders MSA - Mazak – HMAZ - with internal coolant and ACS

Adattatori di troncatura MSA - Mazak - HMAZ - con refrigerazione interna e ACS

Seite/Page/Pagina **540**



Abstechhalter-MSA - Mazak – HMAZ - mit Innenkühlung und ACS

Part-off-holders MSA - Mazak – HMAZ - with internal coolant and ACS

Adattatori di troncatura MSA - Mazak - HMAZ - con refrigerazione interna e ACS

Seite/Page/Pagina **542**



Abstechhalter-MSA - Mazak - Für Monoblockhalter – HMAZ - mit Innenkühlung und ACS

Part-off-holders MSA - Mazak - For monoblock holders – HMAZ - with internal coolant and ACS

Adattatori di troncatura MSA - Mazak- per steli monoblocci - HMAZ - con refrigerazione interna e ACS

Seite/Page/Pagina **544**



Abstechhalter-MSA - Miyano – HMD - mit Innenkühlung

Part-of-holders MSA - Miyano – HMD - with internal coolant

Adattatori di troncatura MSA - Miyano – HMD - con refrigerazione interna

Seite/Page/Pagina **546**

Werkzeughalter / Part-off holders / Adattatori di troncatura



Abstechhalter-MSA - Miyano – HMD / HMSA - mit Innenkühlung und ACS
Part-off-holders MSA - Miyano – HMD / HMSA - with internal coolant and ACS
Adattatori di troncatura MSA - Miyano – HMD / HMSA - con refrigerazione interna e ACS
Seite/Page/Pagina **548**



Abstechhalter-MSA - Miyano – HMSA - mit ACS
Part-off-holders MSA - Miyano – HMSA - with ACS
Adattatori di troncatura MSA - Miyano – HMSA - con ACS
Seite/Page/Pagina **550**

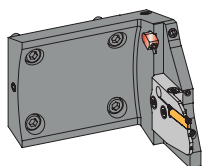

Abstechhalter-MSA - Miyano – HMSA - mit Innenkühlung und ACS
Part-off-holders MSA - Miyano – HMSA - with internal coolant and ACS
Adattatori di troncatura MSA - Miyano – HMSA - con refrigerazione interna e ACS
Seite/Page/Pagina **552**



Abstechhalter-MSA - Miyano – HMSA - mit ACS
Part-off-holders MSA - Miyano – HMSA - with ACS
Adattatori di troncatura MSA - Miyano – HMSA - con ACS
Seite/Page/Pagina **554**



Abstechhalter-MSA - Mori Seiki – NZ, NL - mit Innenkühlung und ACS
Part-off-holders MSA - Mori Seiki – NZ, NL - with internal coolant and ACS
Adattatori di troncatura MSA - Mori Seiki – NZ, NL - con refrigerazione interna e ACS
Seite/Page/Pagina **556**



Abstechhalter-MSA - Mori Seiki – NZ, NL - mit Innenkühlung und ACS
Part-off-holders MSA - Mori Seiki – NZ, NL - with internal coolant and ACS
Adattatori di troncatura MSA - Mori Seiki – NZ, NL - con refrigerazione interna e ACS
Seite/Page/Pagina **558**



Abstechhalter-MSA - Mori Seiki – NZ - mit Innenkühlung und ACS
Part-off-holders MSA - Mori Seiki – NZ - with internal coolant and ACS
Adattatori di troncatura MSA - Mori Seiki – NZ - con refrigerazione interna e ACS
Seite/Page/Pagina **560**



Abstechhalter-MSA - Murata – HMU - mit Innenkühlung und ACS
Part-off-holders MSA - Murata – HMU. - with internal coolant and ACS
Adattatori di troncatura MSA - Murata – HMU - con refrigerazione interna e ACS
Seite/Page/Pagina **562**

Werkzeughalter / Part-off holders / Adattatori di troncatura



Abstechhalter-MSA - Murata – HMU - mit Innenkühlung und ACS

Part-off-holders MSA - Murata – HMU. - with internal coolant and ACS

Adattatori di troncatura MSA - Murata – HMU - con refrigerazione interna e ACS

Seite/Page/Pagina **564**

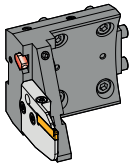

Abstechhalter-MSA - Nakamura – WT100/WY100/NTY3/WT150 - mit Innenkühlung

Part-off-holders MSA - Nakamura – WT100/WY100/NTY3/WT150 - with internal coolant

Adattatori di troncatura MSA - Nakamura – WT100/WY100/NTY3/WT150 - con refrigerazione interna

Seite/Page/Pagina **566**



Abstechhalter-MSA - Nakamura – RB62 / RB80 - mit Innenkühlung und ACS

Part-off-holders MSA - Nakamura – RB62 / RB80 - with internal coolant and ACS

Adattatori di troncatura MSA - Nakamura – RB62 / RB80 - con refrigerazione interna e ACS

Seite/Page/Pagina **568**

Direktaufnahmen für Mehrspindler

Flange mounted holders for multi spindle machines

Adattatori per macchine a fantina mobile montaggio torretta



Abstechhalter-MSA-I.. - Index – MS22 / MS32-40 / MS52 - mit Innenkühlung und ACS

Part-off-holders- MSA-I.. - Index – MS22 / MS32-40 / MS52 - with internal coolant and ACS

Adattatori di troncatura-MSA-I.. - Index – MS22 / MS32-40 / MS52 - con refrigerazione interna e ACS

Seite/Page/Pagina **570**



Abstechhalter-MSA-I.. - Schnittstelle Göldenbodt – GWS02/GWS09/GWS41 - mit Innenkühlung und ACS

Part-off-holders-MSA-I.. - interface Göldenbodt – GWS02/GWS09/GWS41

- with internal coolant and ACS

Adattatori di troncatura-MSA-I.. - attacco Göldenbodt - GWS02/GWS09/GWS41

- con refrigerazione interna e ACS

Seite/Page/Pagina **572**



Abstechhalter-MSA-I.. - Schnittstelle Göldenbodt – GWS02 - mit Innenkühlung und ACS

Part-off-holders-MSA-I.. - interface Göldenbodt – GWS02 - with internal coolant and ACS

Adattatori di troncatura-MSA-I.. - attacco Göldenbodt - GWS02 - con refrigerazione interna e ACS

Seite/Page/Pagina **574**

Form B1 – kurz / Form B1 - short / Forma B1 - corta DIN 69880

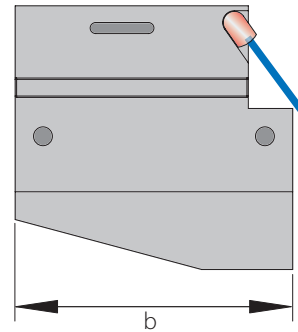
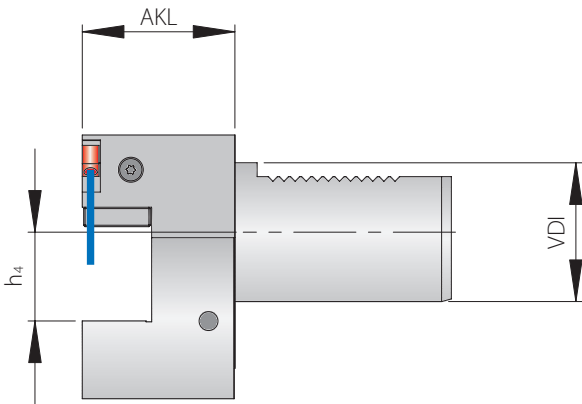
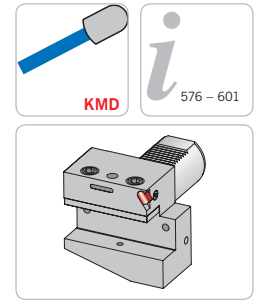

Grundhalter / Basic holder / Adattore

Bezeichnung Designation Articolo	VDI	h ₄	AKL	b	PG 47
KMH01-B1-16X12X24	16	12	24	42	●
KMH01-B1-20X16X30	20	16	30	55	●
KMH01-B1-50X32X55	50	32	55	100	●

Ersatzteile / Spare Parts / Ricambi

Trägerwerkzeug Holder Utensile	Kühlmitteldüse Coolant jet Ugello refrigerante	Schraube für Kühlmitteldüse Screw for coolant jet Vite per ugello refrigerante
KMH01-B1-16.. - KMH01-B1-20..	KMD 0519	AS 0020
KMH01-B1-50..	KMD 0830	AS 0020

KMH-Werkzeugaufnahmen für Monoblockhalter ACS...-UN

KMH holders for monoblock holders ACS...-UN
 Adattatori KMH per utensili monoblocco ACS...-UN

Form B1 – kurz mit Innenkühlung

Form B1 - short with internal coolant

Forma B1 - corta con refrigerazione interna

DIN 69880

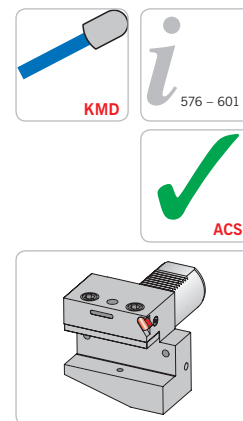
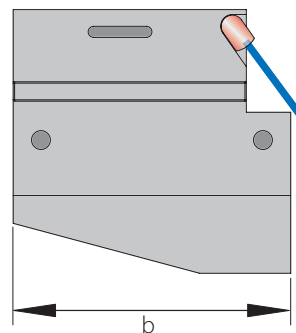
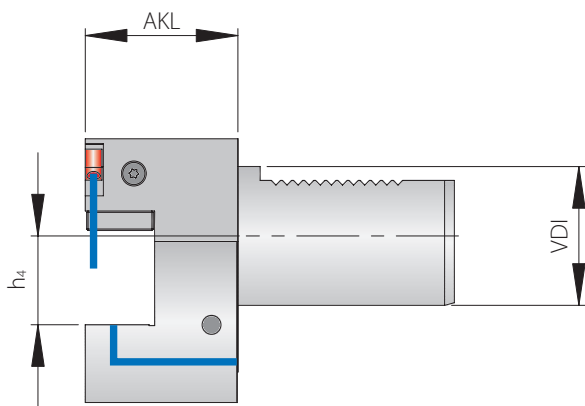

Trägerwerkzeuge / Holders / Utensili

Bezeichnung Designation Articolo	VDI	h ₄	AKL	b	PG 47
KMH01-B1-25X16X30-IK	25	16	30	55	●
KMH01-B1-30X20X40-IK	30	20	40	70	●
KMH01-B1-40X25X44-IK	40	25	44	85	●

Ersatzteile / Spare Parts / Ricambi

Trägerwerkzeug Holder Utensile	Kühlmitteldüse Coolant jet Ugello refrigerante	Schraube für Kühlmitteldüse Screw for coolant jet Vite per ugello refrigerante
KMH01-B1-25...-IK	KMD 0519	AS 0020
KMH01-B1-30.. - KMH01-B1-40...-IK	KMD 0830	AS 0020

Form B2 – kurz / Form B2 - short / Forma B2 - corta

DIN 69880

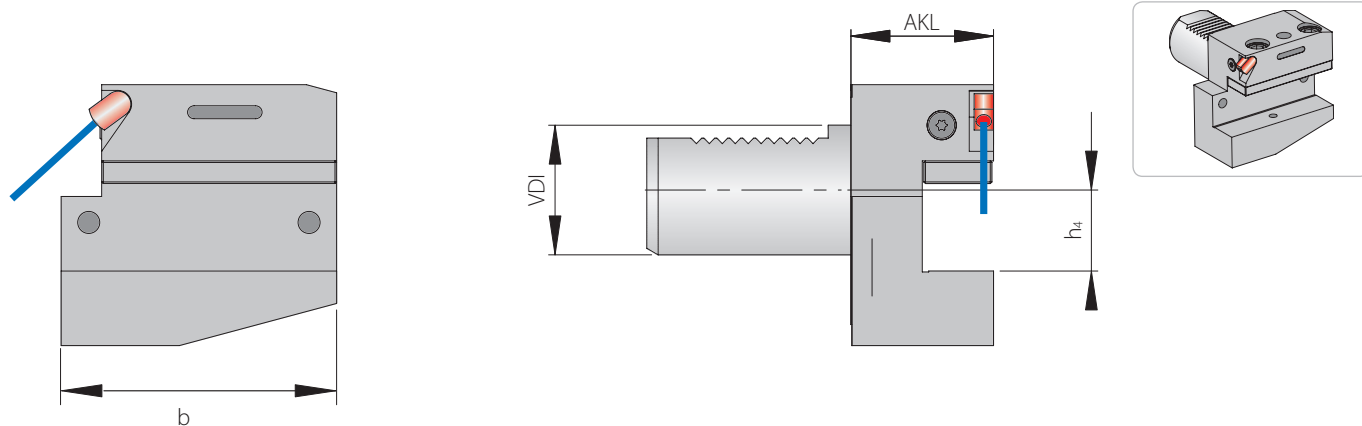

Grundhalter / Basic holder / Adattore

Bezeichnung Designation Articolo	VDI	h_4	AKL	b	PG 47
KMH01-B2-40X25X70	40	25	70	85	●

Ersatzteile / Spare Parts / Ricambi

Trägerwerkzeug Holder Utensile	Kühlmitteldüse Coolant jet Ugello refrigerante	Schraube für Kühlmitteldüse Screw for coolant jet Vite per ugello refrigerante
KMH01-B2-40..	KMD 0830	AS 0020

KMH-Werkzeugaufnahmen für Monoblockhalter ACS...-UN

KMH holders for monoblock holders ACS...-UN

Adattatori KMH per utensili monoblocco ACS...-UN

Form B2 – kurz mit Innenkühlung

Form B2 - short with internal coolant

Forma B2 - corta con refrigerazione interna

DIN 69880

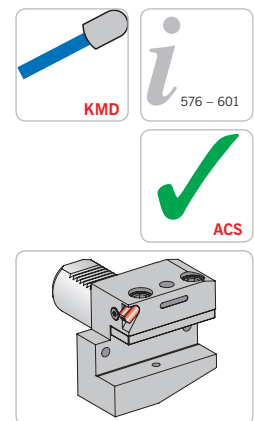
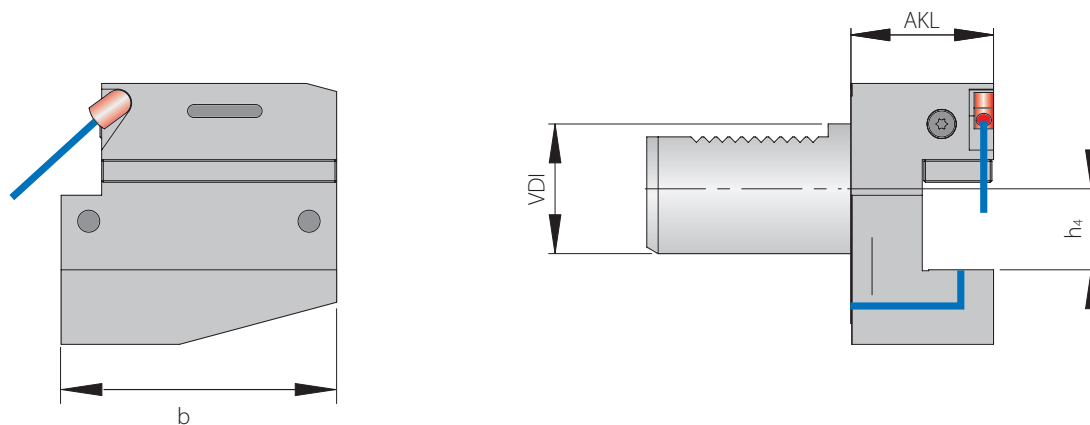

Trägerwerkzeuge / Holders / Utensili

Bezeichnung Designation Articolo	VDI	h_4	AKL	b	PG 47
KMH01-B2-25X16X30-IK	25	16	30	55	●
KMH01-B2-30X20X40-IK	30	20	40	70	●
KMH01-B2-40X25X44-IK	40	25	44	85	●

Ersatzteile / Spare Parts / Ricambi

Trägerwerkzeug Holder Utensile	Kühlmitteldüse Coolant jet Ugello refrigerante	Schraube für Kühlmitteldüse Screw for coolant jet Vite per ugello refrigerante
KMH01-B2-25...-IK	KMD 0519	AS 0020
KMH01-B2-30.. - KMH01-B2-40...-IK	KMD 0830	AS 0020

Form B3 – Überkopf – kurz / Form B3 - Overhead - short / Forma B3 - Invertito - corta

DIN 69880

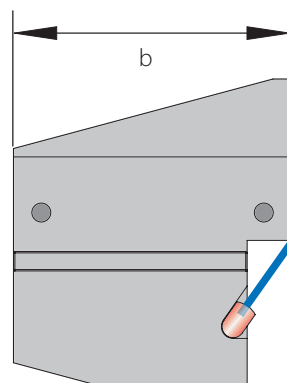
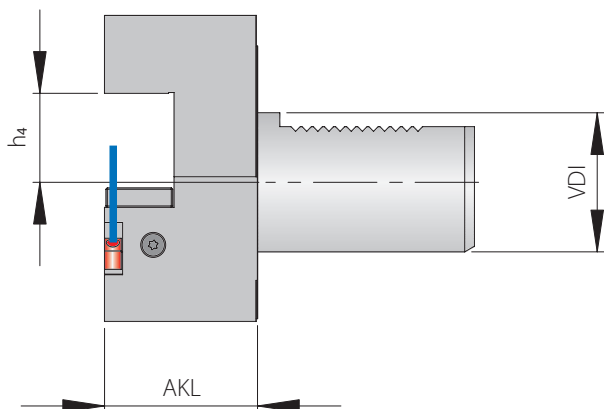
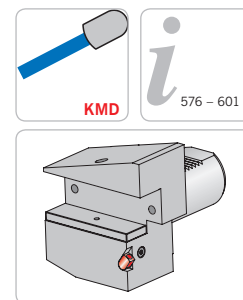

Grundhalter / Basic holder / Adattore

Bezeichnung Designation Articolo	VDI	h ₄	AKL	b	PG 47
KMH01-B3-16X12X24	16	12	24	42	●
KMH01-B3-20X16X30	20	16	30	55	●
KMH01-B3-50X32X55	50	32	55	100	●

Ersatzteile / Spare Parts / Ricambi

Trägerwerkzeug Holder Utensile	Kühlmitteldüse Coolant jet Ugello refrigerante	Schraube für Kühlmitteldüse Screw for coolant jet Vite per ugello refrigerante
KMH01-B3-16.. - KMH01-B3-20..	KMD 0519	AS 0020
KMH01-B3-50..	KMD 0830	AS 0020

KMH-Werkzeugaufnahmen für Monoblockhalter ACS..-UN

KMH holders for monoblock holders ACS..-UN

Adattatori KMH per utensili monoblocco ACS..-UN

Form B3 – Überkopf – kurz mit Innenkühlung

Form B3 - Overhead - short with internal coolant

Forma B3 - Invertito - corta con refrigerazione interna

DIN 69880

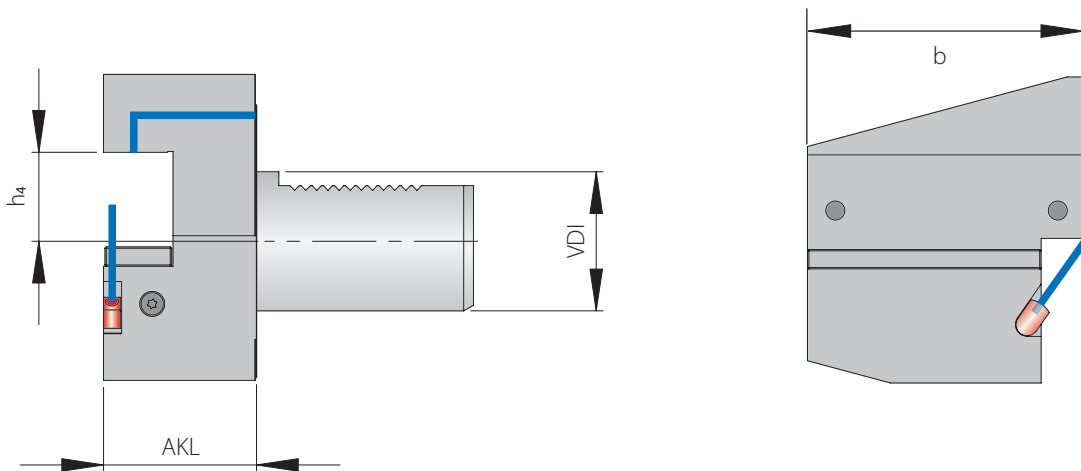
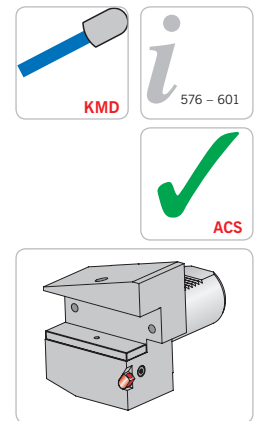

Trägerwerkzeuge / Holders / Utensili

Bezeichnung Designation Articolo	VDI	h ₄	AKL	b	PG 47
KMH01-B3-25X16X30-IK	25	16	30	55	●
KMH01-B3-30X20X40-IK	30	20	40	70	●
KMH01-B3-40X25X44-IK	40	25	44	85	●

Ersatzteile / Spare Parts / Ricambi

Trägerwerkzeug Holder Utensile	Kühlmitteldüse Coolant jet Ugello refrigerante	Schraube für Kühlmitteldüse Screw for coolant jet Vite per ugello refrigerante
KMH01-B3-25..-IK	KMD 0519	AS 0020
KMH01-B3-30.. - KMH01-B3-40..-IK	KMD 0830	AS 0020

Form B4 – Überkopf – kurz / Form B4 - Overhead - short / Forma B4 - Invertito - corta

DIN 69880

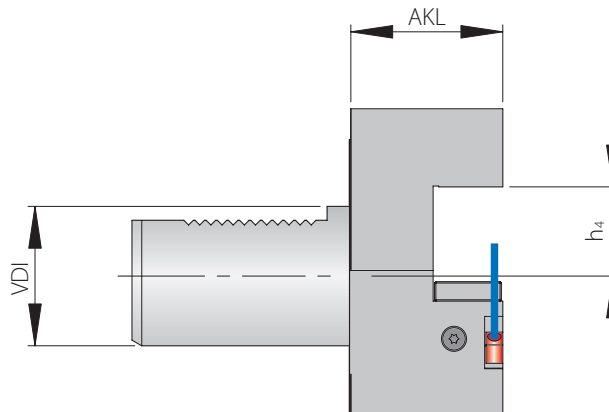
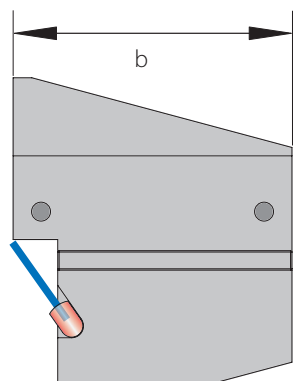
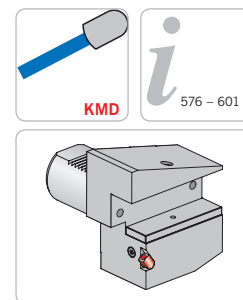

Grundhalter / Basic holder / Adattore

Bezeichnung Designation Articolo	VDI	h_4	AKL	b	PG 47
KMH01-B4-16X12X24	16	12	24	42	●
KMH01-B4-20X16X30	20	16	30	55	●
KMH01-B4-50X32X55	50	32	55	100	●

Ersatzteile / Spare Parts / Ricambi

Trägerwerkzeug Holder Utensile	Kühlmitteldüse Coolant jet Ugello refrigerante	Schraube für Kühlmitteldüse Screw for coolant jet Vite per ugello refrigerante
KMH01-B4-16.. - KMH01-B4-20..	KMD 0519	AS 0020
KMH01-B4-50..	KMD 0830	AS 0020

KMH-Werkzeugaufnahmen für Monoblockhalter ACS...-UN

KMH holders for monoblock holders ACS...-UN

Adattatori KMH per utensili monoblocco ACS...-UN

Form B4 – Überkopf – kurz mit Innenkühlung

Form B4 - Overhead - short with internal coolant

Forma B4 - Invertito - corta con refrigerazione interna

DIN 69880

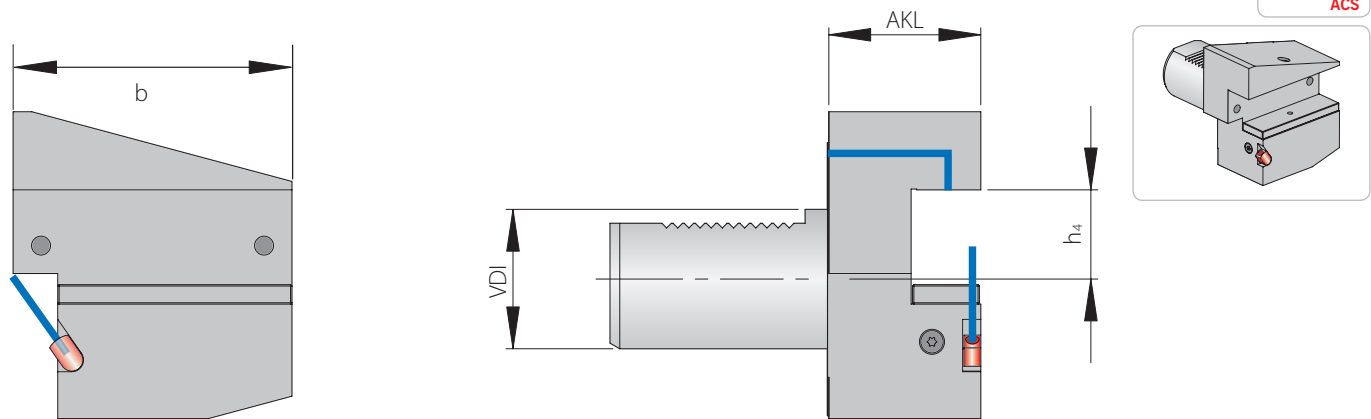

Trägerwerkzeuge / Holders / Utensili

Bezeichnung Designation Articolo	VDI	h ₄	AKL	b	PG 47
KMH01-B4-25X16X30-IK	25	16	30	55	●
KMH01-B4-30X20X40-IK	30	20	40	70	●
KMH01-B4-40X25X44-IK	40	25	44	85	●

Ersatzteile / Spare Parts / Ricambi

Trägerwerkzeug Holder Utensile	Kühlmitteldüse Coolant jet Ugello refrigerante	Schraube für Kühlmitteldüse Screw for coolant jet Vite per ugello refrigerante
KMH01-B4-25...-IK	KMD 0519	AS 0020
KMH01-B4-30.. - KMH01-B4-40...-IK	KMD 0830	AS 0020

Form B5 – lang / Form B5 - long / Forma B5 - lunga

DIN 69880

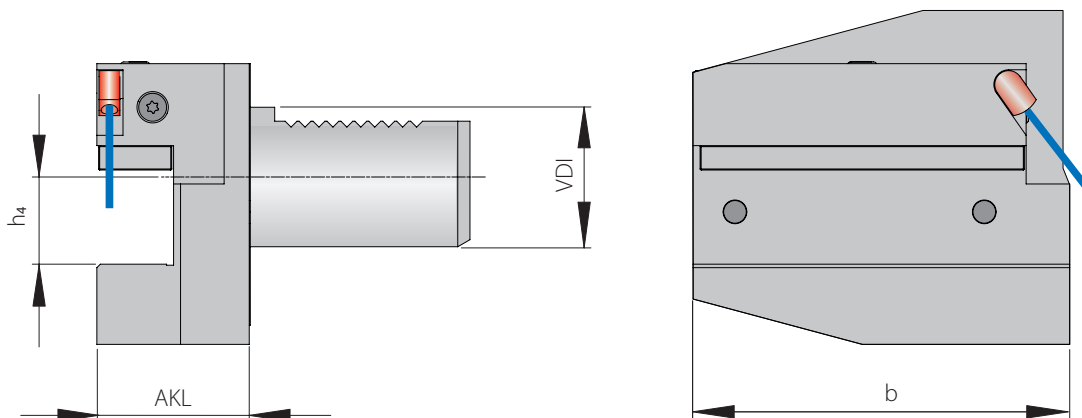
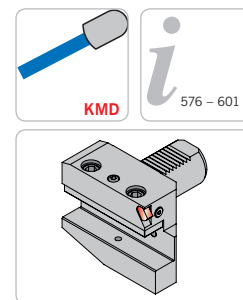

Grundhalter / Basic holder / Adattore

Bezeichnung Designation Articolo	VDI	h_4	AKL	b	PG 47
KMH01-B5-40X25X44	40	25	44	108	●

Ersatzteile / Spare Parts / Ricambi

Trägerwerkzeug Holder Utensile	Kühlmitteldüse Coolant jet Ugello refrigerante	Schraube für Kühlmitteldüse Screw for coolant jet Vite per ugello refrigerante
KMH01-B5-40..	KMD 0830	AS 0020

Form B6 – lang / Form B6 - long / Forma B6 - lunga

DIN 69880

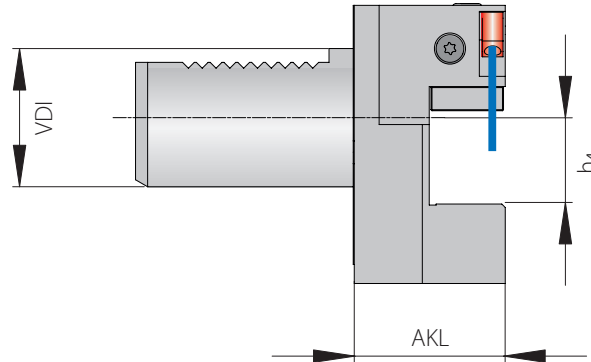
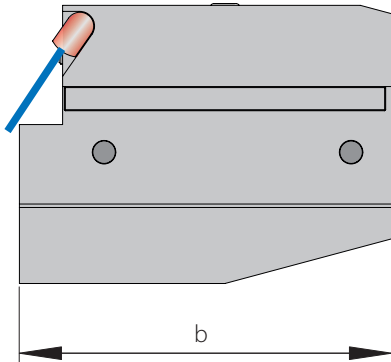
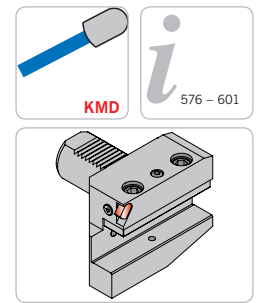

Grundhalter / Basic holder / Adattore

Bezeichnung Designation Articolo	VDI	h_4	AKL	b	PG 47
KMH01-B6-40X25X44	40	25	44	108	●

Ersatzteile / Spare Parts / Ricambi

Trägerwerkzeug Holder Utensile	Kühlmitteldüse Coolant jet Ugello refrigerante	Schraube für Kühlmitteldüse Screw for coolant jet Vite per ugello refrigerante
KMH01-B6-40..	KMD 0830	AS 0020

Form B7 – Überkopf – lang / Form B7 - Overhead - long / Forma B7 - Invertito - lunga

DIN 69880

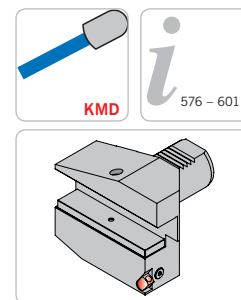
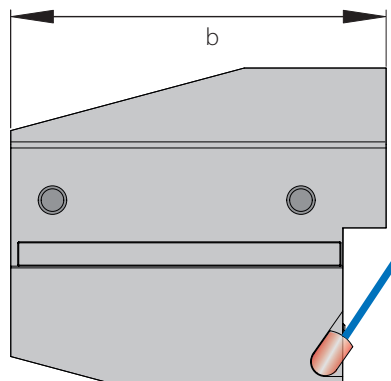
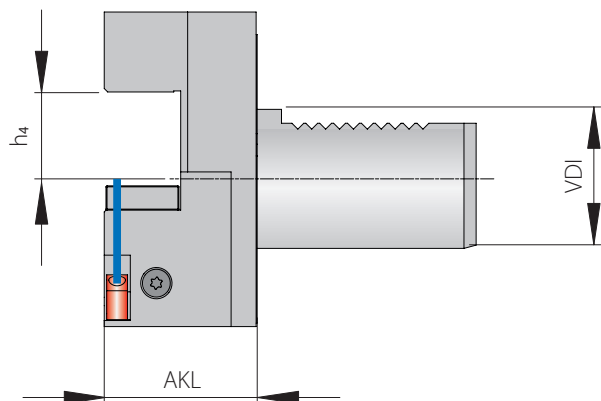

Grundhalter / Basic holder / Adattore

Bezeichnung Designation Articolo	VDI	h_4	AKL	b	PG 47
KMH01-B7-40X25X44	40	25	44	108	●

Ersatzteile / Spare Parts / Ricambi

Trägerwerkzeug Holder Utensile	Kühlmitteldüse Coolant jet Ugello refrigerante	Schraube für Kühlmitteldüse Screw for coolant jet Vite per ugello refrigerante
KMH01-B7-40..	KMD 0830	AS 0020

ARNO®

WERKZEUGE

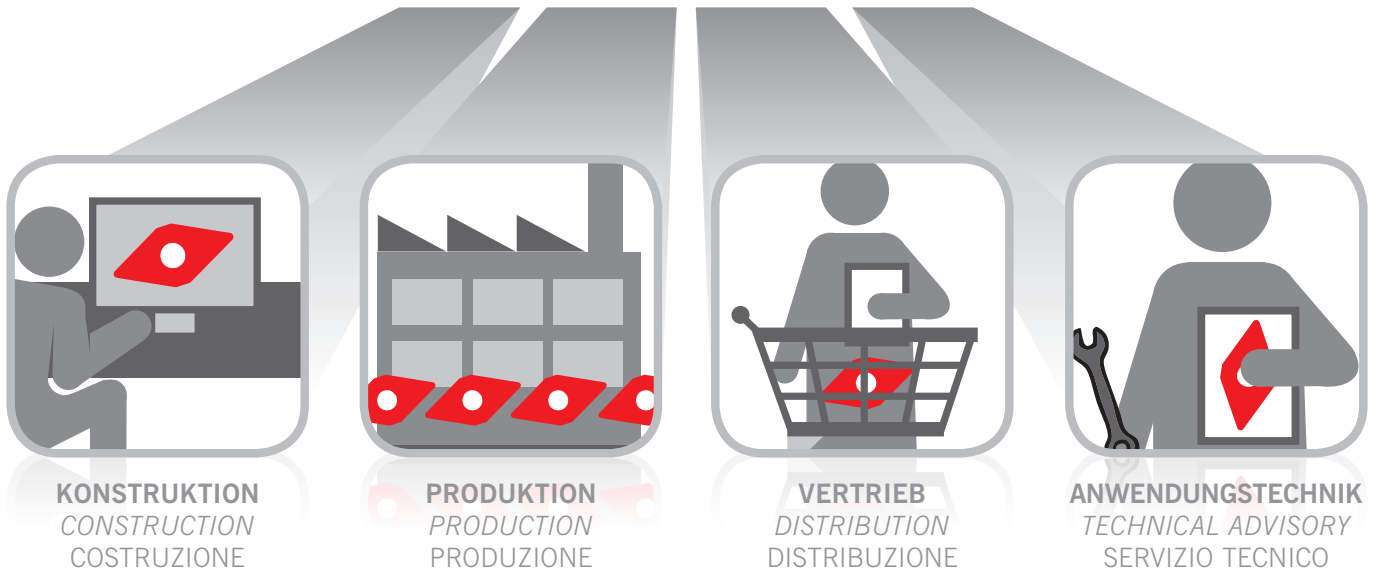

Schnell, flexibel und individuell.

Quick, flexible and individual.

Veloce, flessibile e individuale.

Konstruktion, Produktion und Vertrieb unter einem Dach.

Das ist die perfekte Verbindung um Ihnen Standard- und Sonderprodukte schnell und hochwertig anbieten zu können.

95% der Standardprodukte sind sofort verfügbar: Bei Bestellung bis 18 Uhr erhalten Sie Ihre Produkte bereits am nächsten Tag.

Mit großer fachlicher Kompetenz betreut Sie unser Außendienst-Team, unsere Anwendungstechniker helfen Ihnen mit Spezial-Wissen gerne auch vor Ort.

To have design, production and service all under one roof

is the perfect way of providing standard and special products.

95% of the standard programme is available from stock. Order received before 18.00 CET are dispatched the very same day and in most cases supplied next day.

Our competent team of technical sales engineers will be available to support you on site.

Costruzione, Produzione e Distribuzione sotto un unico tetto.

La sequenza perfetta per garantire un servizio di supporto cliente su prodotti Standard e Speciali di alta qualità.

Il 95% dei prodotti Standard sono disponibili a stock; con ordini entro le 18:00 garantiamo la consegna il giorno successivo.

Il nostro team di vendita altamente qualificato si offre come supporto alla produzione presso i nostri clienti direttamente sul territorio.

Weitere Informationen finden Sie unter:

For more information see:

Altre informazioni su:

www.arno.de

Form C1 / Form C1 / Forma C1 DIN 69880

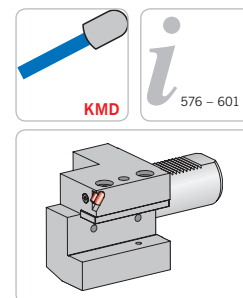
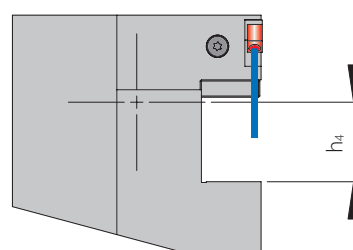
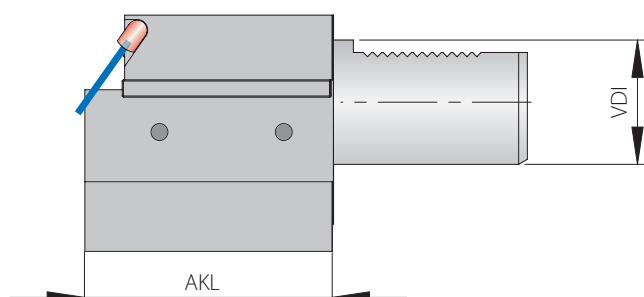

Grundhalter / Basic holder / Adattore

Bezeichnung Designation Articolo	VDI	h ₄	AKL	PG 47
KMH01-C1-25X20	25	20	55	●
KMH01-C1-50X32	50	32	100	●

Ersatzteile / Spare Parts / Ricambi

Trägerwerkzeug Holder Utensile	Kühlmitteldüse Coolant jet Ugello refrigerante	Schraube für Kühlmitteldüse Screw for coolant jet Vite per ugello refrigerante
KMH01-C1-25.. - KMH01-C1-50..	KMD 0519	AS 0020

KMH-Werkzeugaufnahmen für Monoblockhalter ACS...-UN

KMH holders for monoblock holders ACS...-UN

Adattatori KMH per utensili monoblocco ACS...-UN

Form C1 - mit Innenkühlung

Form C1 - with internal coolant

Forma C1 - con refrigerazione interna

DIN 69880

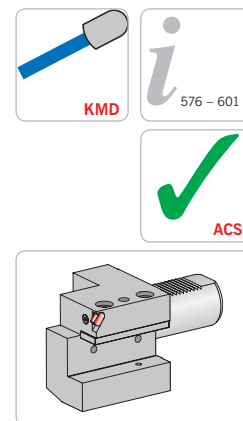
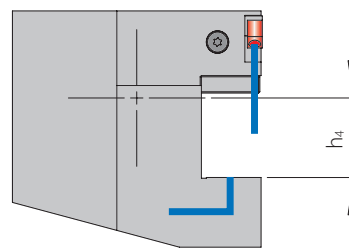
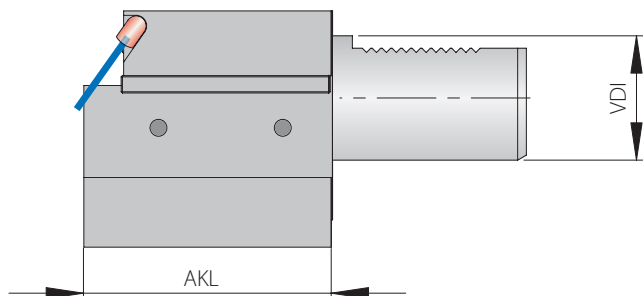

Trägerwerkzeuge / Holders / Utensili

Bezeichnung Designation Articolo	VDI	h_4	AKL	PG 47
KMH01-C1-25X16X55-IK	25	16	55	●
KMH01-C1-30X20X70-IK	30	20	70	●
KMH01-C1-40X25X85-IK	40	25	85	●

Ersatzteile / Spare Parts / Ricambi

Trägerwerkzeug Holder Utensile	Kühlmitteldüse Coolant jet Ugello refrigerante	Schraube für Kühlmitteldüse Screw for coolant jet Vite per ugello refrigerante
KMH01-C1-25...-IK	KMD 0519	AS 0020
KMH01-C1-30.. - KMH01-C1-40...-IK	KMD 0830	AS 0020

Form C2 / Form C2 / Forma C2

DIN 69880

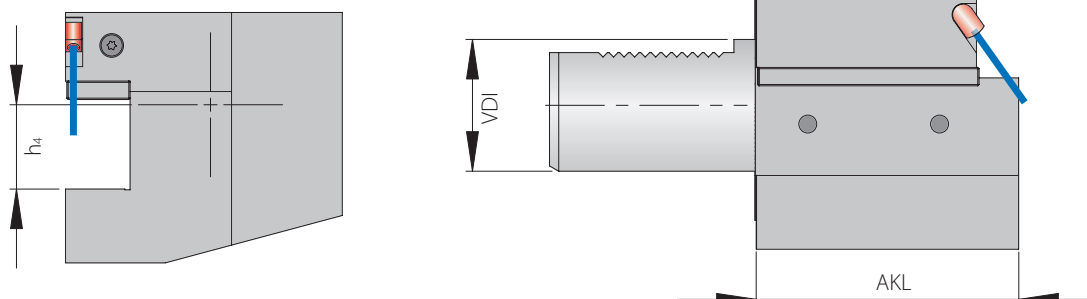
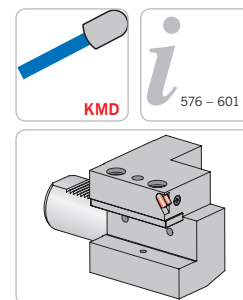

Grundhalter / Basic holder / Adattore

Bezeichnung Designation Articolo	VDI	h ₄	AKL	PG 47
KMH01-C2-16X12	16	12	44	●
KMH01-C2-20X16	20	16	50	●
KMH01-C2-50X32	50	32	100	●

Ersatzteile / Spare Parts / Ricambi

Trägerwerkzeug Holder Utensile	Kühlmitteldüse Coolant jet Ugello refrigerante	Schraube für Kühlmitteldüse Screw for coolant jet Vite per ugello refrigerante
KMH01-C2-16.. - KMH01-C2-50..	KMD 0519	AS 0020

KMH-Werkzeugaufnahmen für Monoblockhalter ACS...-UN

KMH holders for monoblock holders ACS...-UN

Adattatori KMH per utensili monoblocco ACS...-UN

Form C2 - mit Innenkühlung

Form C2 - with internal coolant

Forma C2 - con refrigerazione interna

DIN 69880

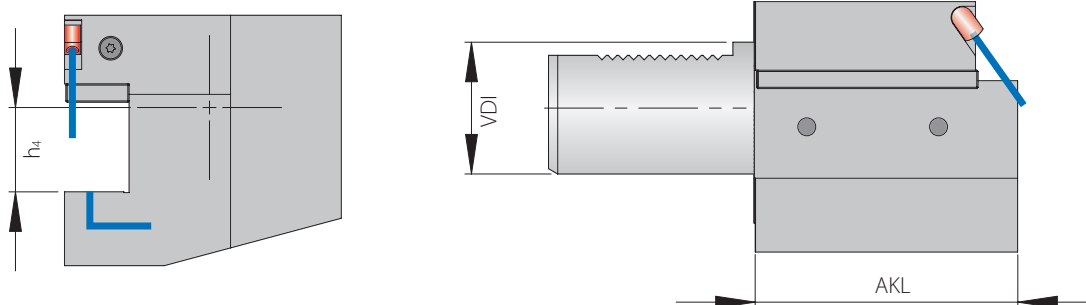
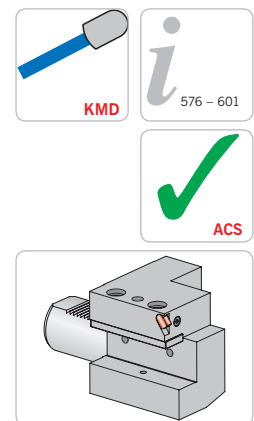

Trägerwerkzeuge / Holders / Utensili

Bezeichnung Designation Articolo	VDI	h_4	AKL	PG 47
KMH01-C2-25X16X55-IK	25	16	55	●
KMH01-C2-30X20X70-IK	30	20	70	●
KMH01-C2-40X25X85-IK	40	25	85	●

Ersatzteile / Spare Parts / Ricambi

Trägerwerkzeug Holder Utensile	Kühlmitteldüse Coolant jet Ugello refrigerante	Schraube für Kühlmitteldüse Screw for coolant jet Vite per ugello refrigerante
KMH01-C2-25...-IK	KMD 0519	AS 0020
KMH01-C2-30.. - KMH01-C2-40...-IK	KMD 0830	AS 0020

Form C3 – Überkopf / Form C3 - Overhead / Forma C3 - Invertito DIN 69880

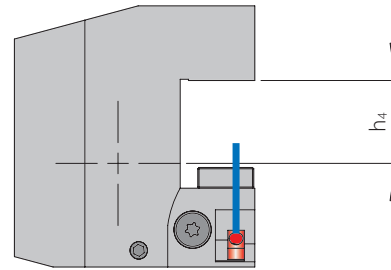
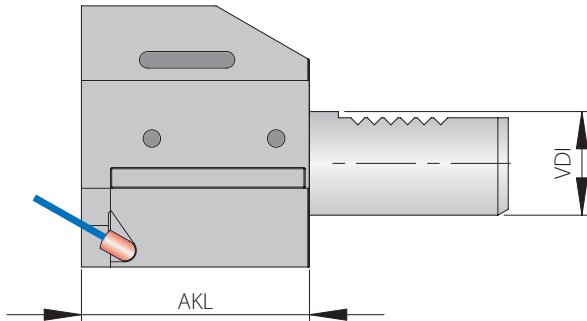
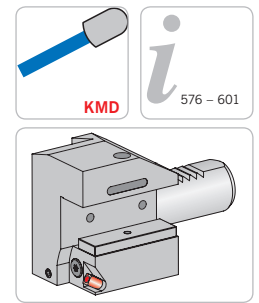

Grundhalter / Basic holder / Adattore

Bezeichnung Designation Articolo	VDI	h ₄	AKL	PG 47
KMH01-C3-16X12	16	12	44	●
KMH01-C3-20X16	20	16	50	●
KMH01-C3-50X32	50	32	100	●

Ersatzteile / Spare Parts / Ricambi

Trägerwerkzeug Holder Utensile	Kühlmitteldüse Coolant jet Ugello refrigerante	Schraube für Kühlmitteldüse Screw for coolant jet Vite per ugello refrigerante
KMH01-C3-16.. - KMH01-C3-50..	KMD 0519	AS 0020

KMH-Werkzeugaufnahmen für Monoblockhalter ACS...-UN

KMH holders for monoblock holders ACS...-UN

Adattatori KMH per utensili monoblocco ACS...-UN

Form C3 – Überkopf mit Innenkühlung

Form C3 - Overhead with internal coolant

Forma C3 - Invertito con refrigerazione interna

DIN 69880

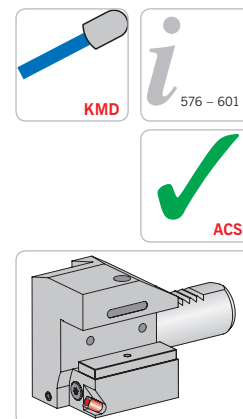
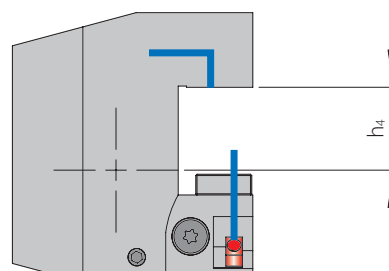
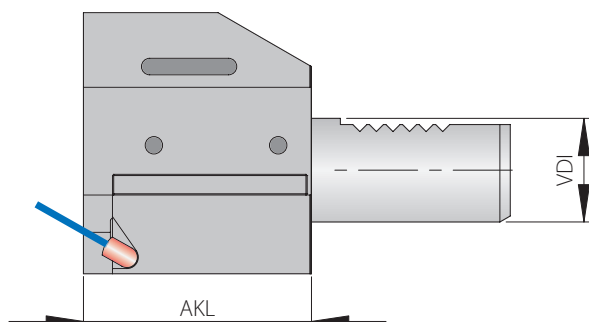

Trägerwerkzeuge / Holders / Utensili

Bezeichnung Designation Articolo	VDI	h ₄	AKL	PG 47
KMH01-C3-25X16X55-IK	25	16	55	●
KMH01-C3-30X20X70-IK	30	20	70	●
KMH01-C3-40X25X85-IK	40	25	85	●

Ersatzteile / Spare Parts / Ricambi

Trägerwerkzeug Holder Utensile	Kühlmitteldüse Coolant jet Ugello refrigerante	Schraube für Kühlmitteldüse Screw for coolant jet Vite per ugello refrigerante
KMH01-C3-25...-IK	KMD 0519	AS 0020
KMH01-C3-30.. - KMH01-C3-40...-IK	KMD 0830	AS 0020

Form C4 – Überkopf / Form C4 - Overhead / Forma C4 - Invertito DIN 69880

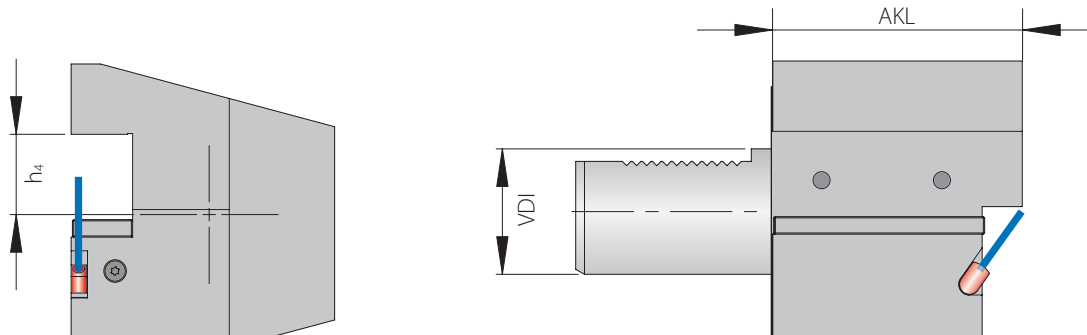
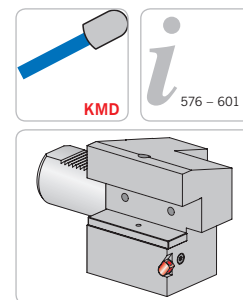

Grundhalter / Basic holder / Adattore

Bezeichnung Designation Articolo	VDI	h ₄	AKL	PG 47
KMH01-C4-16X12	16	12	44	●
KMH01-C4-20X16	20	16	50	●
KMH01-C4-25X20	25	20	55	●
KMH01-C4-50X32	50	32	100	●

Ersatzteile / Spare Parts / Ricambi

Trägerwerkzeug Holder Utensile	Kühlmitteldüse Coolant jet Ugello refrigerante	Schraube für Kühlmitteldüse Screw for coolant jet Vite per ugello refrigerante
KMH01-C4-16.. - KMH01-C4-50..	KMD 0519	AS 0020

KMH-Werkzeugaufnahmen für Monoblockhalter ACS...-UN

KMH holders for monoblock holders ACS...-UN

Adattatori KMH per utensili monoblocco ACS...-UN

Form C4 – Überkopf mit Innenkühlung

Form C4 - Overhead with internal coolant

Forma C4 - Invertito con refrigerazione interna

DIN 69880

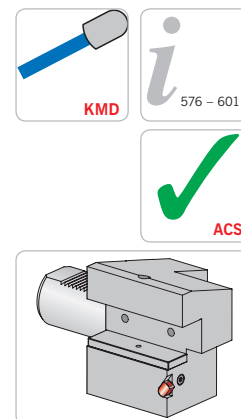
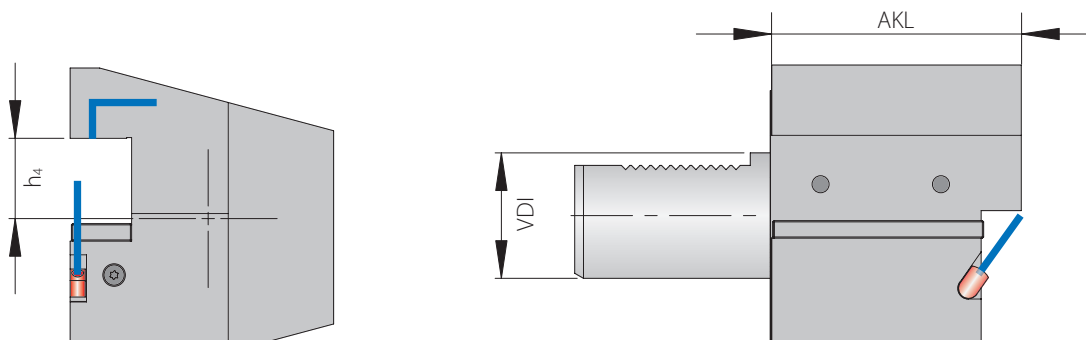

Trägerwerkzeuge / Holders / Utensili

Bezeichnung Designation Articolo	VDI	h ₄	AKL	PG 47
KMH01-C4-25X16X55-IK	25	16	55	●
KMH01-C4-25X20X70-IK	25	20	70	●
KMH01-C4-30X20X70-IK	30	20	70	●
KMH01-C4-40X25X85-IK	40	25	85	●

Ersatzteile / Spare Parts / Ricambi

Trägerwerkzeug Holder Utensile	Kühlmitteldüse Coolant jet Ugello refrigerante	Schraube für Kühlmitteldüse Screw for coolant jet Vite per ugello refrigerante
KMH01-C4-25...-IK	KMD 0519	AS 0020
KMH01-C4-30.. - KMH01-C4-40..-IK	KMD 0830	AS 0020

Abstechhalter - MSA

Part-off holder - MSA
Attacchi base - MSA

Abstechhalter und Direktaufnahmen

Part-off holders and flange mounted holders
Adattatori di troncatura e attacchi base

VDI25 - mit Innenkühlung / VDI25 - with internal coolant / VDI25 - con refrigerazione interna

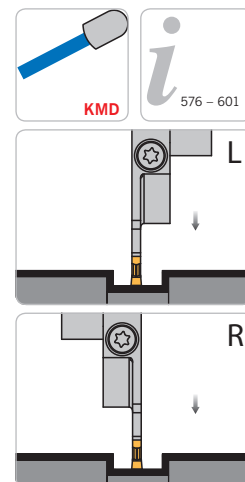
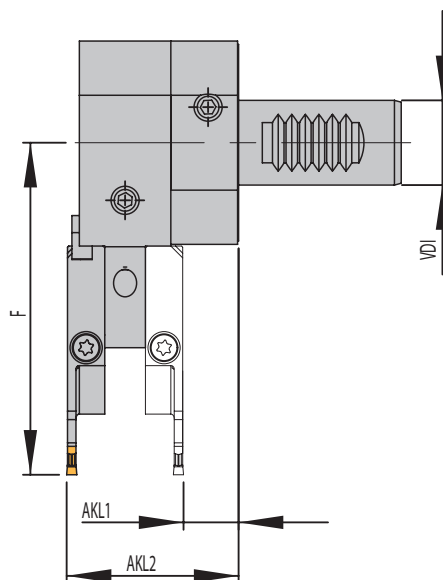
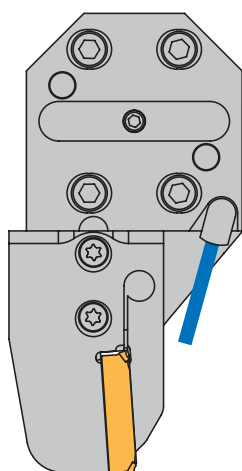

Linkes Modul montiert
Halter höhenjustierbar
Rechtes Modul alternativ
Left module shown
Height adjustable holder
Right module alternative
Modulo sinistro in figura
Adattatore registrabile in altezza
Modulo destro alternativa

Grundhalter / Basic holder / Adattore

Bezeichnung Designation Articolo	VDI	AKL1	AKL2	Modul Module Modulo	PG 43
HVDS 25-1	25	16,3	50,8	MSA-...	●

Modul / Module / Modulo

F = Maße bei Modul MSA-... / F = dimension of Modul MSA-... / F = Lunghezza con modulo MSA-...

Bezeichnung Designation Articolo	VDI25...
	F
MSA-...-32	82,5
MSA-...-44	87,5
MSA-...-52	98,0
MSA-...-65	98,0
MSA-...-80	105,5
MSA-...-105	118,5
MSA-...-125	128,5
MSA-...-140	136,0

Hinweis: Passende Module finden Sie im Kapitel SA (Seite 114 bis 128)

Remark: For modules to suit please see chapter SA (Page 114 to 128)

Nota: Per I moduli abbinabili vedere pagine da 114 a 128





Ersatzteile / Spare Parts / Ricambi

Trägerwerkzeug Holder Utensile	Schraube für Modul Screw for module Vite per modulo	Schlüssel Key Chiave	Kühlmitteldüse Coolant jet Ugello refrigerante
HVDS 25-1	AS 0070	T5220-IP	KMD 0825-3E

Ersatzteile / Spare Parts / Ricambi

Modul Module Modulo	Schraube für Modul Screw for module Vite per modulo	Schlüssel Key Chiave
MSA-...	SA5T	T5220-IP

Einbaumöglichkeiten / Assembly options / Combinazioni di montaggio

<p>Linkes Modul montiert <i>Left module shown</i> Modulo sinistro in figura</p>	<p>Rechtes Modul montiert <i>Right module shown</i> Modulo destro in figura</p>
	
<p>Einbaulage normal <i>Normal assembly</i> Montaggio normale</p>	<p>Einbaulage normal <i>Normal assembly</i> Montaggio normale</p>
	
<p>Einbaulage Überkopf <i>Upside down assembly</i> Montaggio invertito</p>	<p>Einbaulage Überkopf <i>Upside down assembly</i> Montaggio invertito</p>

Hinweis: Mit einem Halter sind alle abgebildeten Varianten montierbar.

Remark: All shown options are available with only one holder.

Nota: E' sufficiente un solo corpo base per comporre tutte le combinazioni raffigurate.

Hinweis: Sonderabmessungen und Abstechhalter für andere Maschinenhersteller auf Anfrage erhältlich. Ein Anfrageblatt hierzu finden Sie auf Seite 578 oder im Internet unter: www.arno.de/service/downloads

Remark: Custom made part-off holders for other machine manufacturers are available on request. Please complete enquiry sheet on page 578 or download this from www.arno.de/service/downloads

Nota: Adattatori speciali di differenti dimensioni e caratteristiche disponibili a richiesta.

Vedere modulo richiesta a Pagina 578 o download del modulo da: www.arno.de/service/downloads

--> **Anwendungshinweise finden Sie auf S. 584/585**

--> *For application reference please see page 584/585*

--> *Per suggerimenti tecnici vedere pagina 584/585*

Abstechhalter - MSA

Part-off holder - MSA
 Attacchi base - MSA

Abstechhalter und Direktaufnahmen

Part-off holders and flange mounted holders
 Adattatori di troncatura e attacchi base

VDI25 - mit Innenkühlung / VDI25 - with internal coolant / VDI25 - con refrigerazione interna

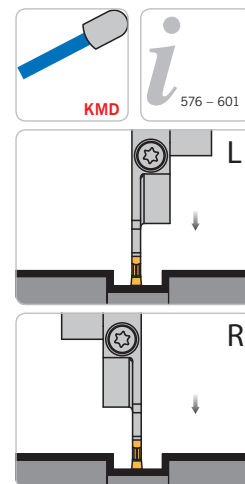
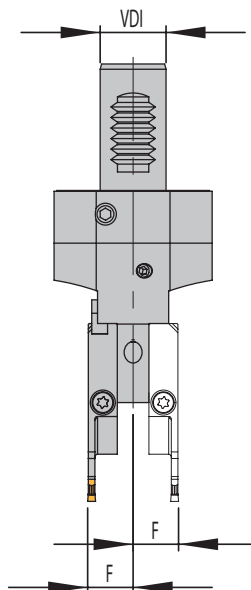
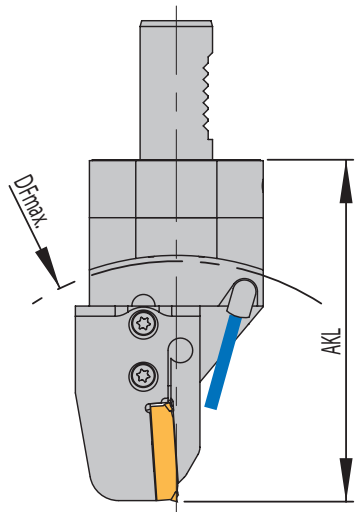

Linkes Modul montiert
 Halter höhenstellbar
 Rechtes Modul alternativ
 Left module shown
 Height adjustable holder
 Right module alternative
 Modulo sinistro in figura
 Adattatore registrabile in altezza
 Modulo destro alternativa

Grundhalter / Basic holder / Adattore

Bezeichnung Designation Articolo	VDI	F	Modul Module Modulo	PG 43
HVDS 25-7	25	17,3	MSA-...	●

Modul / Module / Modulo

DF_{max} = Maximaler Futterdurchmesser und AKL = Ausraglänge bei Modul MSA-... / DF_{max} = maximum chuck diameter and AKL = Overhang length with modules MSA-... / DF_{max} = Diametro max mandrino e AKL = Lunghezza totale con modulo MSA-...

Bezeichnung Designation Articolo	VDI25...	
	AKL	DF_{max}
MSA-...-32	102,5	135
MSA-...-44	107,5	145
MSA-...-52	118,0	165
MSA-...-65	118,0	165
MSA-...-80	125,5	180
MSA-...-105	138,5	205
MSA-...-125	148,5	225
MSA-...-140	156,0	235

Hinweis: Passende Module finden Sie im Kapitel SA (Seite 114 bis 128)

Remark: For modules to suit please see chapter SA (Page 114 to 128)

Nota: Per i moduli abbinabili vedere pagine da 114 a 128

Ersatzteile / Spare Parts / Ricambi





Trägerwerkzeug Holder Utensile	Schraube für Modul Screw for module Vite per modulo	Schlüssel Key Chiave	Kühlmitteldüse Coolant jet Ugello refrigerante
HVDS 25-7	AS 0070	T5220-IP	KMD 0825-3E

Ersatzteile / Spare Parts / Ricambi

Modul Module Modulo	Schraube für Modul Screw for module Vite per modulo	Schlüssel Key Chiave
MSA-...	SA5T	T5220-IP



Einbaumöglichkeiten / Assembly options / Combinazioni di montaggio

Linkes Modul montiert <i>Left module shown</i> Modulo sinistro in figura	Rechtes Modul montiert <i>Right module shown</i> Modulo destro in figura
	
Einbaulage normal <i>Normal assembly</i> Montaggio normale	Einbaulage normal <i>Normal assembly</i> Montaggio normale
	
Einbaulage Überkopf <i>Upside down assembly</i> Montaggio invertito	Einbaulage Überkopf <i>Upside down assembly</i> Montaggio invertito

Hinweis: Mit einem Halter sind alle abgebildeten Varianten montierbar.

Remark: All shown options are available with only one holder.

Nota: E' sufficiente un solo corpo base per comporre tutte le combinazioni raffigurate.

Hinweis: Sonderabmessungen und Abstechhalter für andere Maschinenhersteller auf Anfrage erhältlich. Ein Anfrageblatt hierzu finden Sie auf Seite 578 oder im Internet unter: www.arno.de/service/downloads

Remark: Custom made part-off holders for other machine manufacturers are available on request.

Please complete enquiry sheet on page 578 or download this from www.arno.de/service/downloads

Nota: Adattatori speciali di differenti dimensioni e caratteristiche disponibili a richiesta.

Vedere modulo richiesta a Pagina 578 o download del modulo da: www.arno.de/service/downloads

--> **Anwendungshinweise finden Sie auf S. 584/585**

--> *For application reference please see page 584/585*

--> *Per suggerimenti tecnici vedere pagina 584/585*

VDI25 - mit Innenkühlung und ACS / VDI25 - with internal coolant and ACS / VDI25 - con refrigerazione interna e ACS

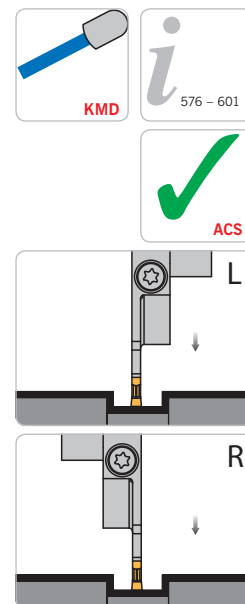
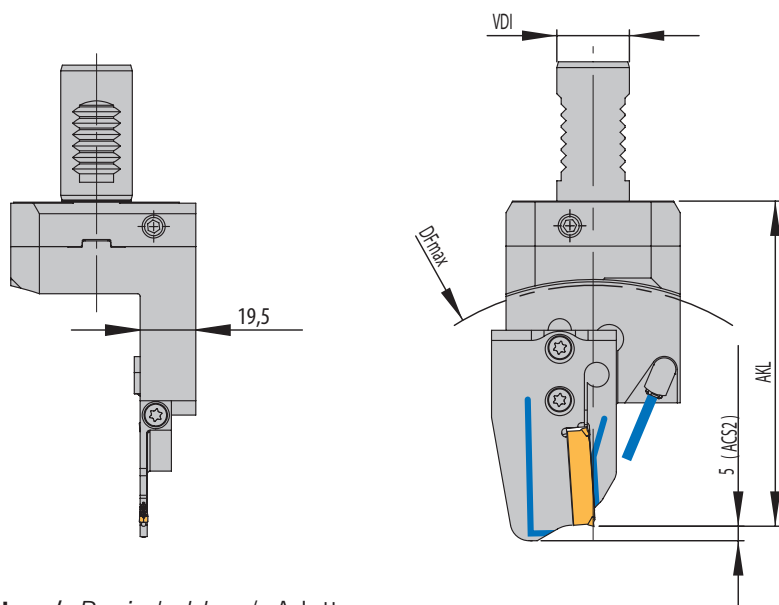

Rechter Halter und linkes Modul montiert
Right holder and left module shown
Adattatore destro e modulo sinistro in figura

Grundhalter / Basic holder / Adattore

Bezeichnung Designation Articolo	VDI	F1	F2	Modul Module Modulo	PG 43
HVDI 25L-7-15-MSA-SR	25	15	-	MSA-SR...ACS.	●
HVDI 25L-7-35-MSA-SL	25	-	35	MSA-SL...ACS.	●
HVDI 25R-7-15-MSA-SL	25	15	-	MSA-SL...ACS.	●
HVDI 25R-7-35-MSA-SR	25	-	35	MSA-SR...ACS.	●
HVDI 25L-7-15-MSA-SR-122	25	15	-	MSA-SR...ACS.	●
HVDI 25L-7-35-MSA-SL-122	25	-	35	MSA-SL...ACS.	●
HVDI 25R-7-15-MSA-SL-122	25	15	-	MSA-SL...ACS.	●
HVDI 25R-7-35-MSA-SR-122	25	-	35	MSA-SR...ACS.	●

Modul / Module / Modulo

DF_{max} = Maximaler Futterdurchmesser und AKL = Auskraglänge bei Modul MSA-... / DF_{max} = maximum chuck diameter and AKL = Overhang length with modules MSA-... / DF_{max} = Diametro max mandrino e AKL = Lunghezza totale con modulo MSA-...

Bezeichnung Designation Articolo	VDI25...		VDI25...-122	
	AKL	DF_{max}	AKL	DF_{max}
MSA-...-32-ACS.	96,5	135	106,5	155
MSA-...-44-ACS.	101,5	145	111,5	165
MSA-...-52-ACS.	112,0	165	122,0	185
MSA-...-65-ACS.	112,0	165	122,0	185
MSA-...-69-ACS.	114,0	170	124,0	190
MSA-...-80-ACS.	119,5	180	129,5	200
MSA-...-90-ACS.	124,5	190	134,5	210
MSA-...-105-ACS.	132,0	205	142,0	225

Hinweis: Passende Module finden Sie im Kapitel SA (Seite 114 bis 128)

Remark: For modules to suit please see chapter SA (Page 114 to 128)

Nota: Per i moduli abbinabili vedere pagine da 114 a 128

Ersatzteile / Spare Parts / Ricambi

Trägerwerkzeug Holder Utensile	Schraube für Modul Screw for module Vite per modulo	Schlüssel Key Chiave	O-Ring O-ring O-Ring	Kühlmitteldüse Coolant jet Ugello refrigerante	Verschluss-Stift Locking pin Spina bloccaggio
HVDI 25.-	AS 0070	T5220-IP	OR 23,6X1,8-NBR80*	KMD 0820-4BJ	ZS0820G

* Nicht im Lieferumfang enthalten.

* Not included in the delivery.

* Non incluso.

Ersatzteile / Spare Parts / Ricambi

Modul Module Modulo	Schraube für Modul Screw for module Vite per modulo	Schlüssel Key Chiave
MSA-...-	SA5T	T5220-IP

Einbaumöglichkeiten / Assembly options / Combinazioni di montaggio

Linker Halter Left-hand holder Adattatore sinistro		Rechter Halter Right-hand holder Adattatore destro	
HVDI 25L-7-35-MSA-SL	HVDI 25L-7-35-MSA-SR	HVDI 25R-7-15-MSA-SL	HVDI 25R 7-15-MSA-SR
HVDI 25L-735-MSA-SL-122	HVDI 25L-7-35-MSA-SR-122	HVDI 25R-7-15-MSA-SL-122	HVDI 25R 7-15-MSA-SR-122
Linkes Modul montiert Left module shown Modulo sinistro in figura	Rechtes Modul montiert Right module shown Modulo destro in figura	Linkes Modul montiert Left module shown Modulo sinistro in figura	Rechtes Modul montiert Right module shown Modulo destro in figura
Einbaulage normal Normal assembly Montaggio normale	Einbaulage normal Normal assembly Montaggio normale	Einbaulage normal Normal assembly Montaggio normale	Einbaulage normal Normal assembly Montaggio normale
Einbaulage Überkopf Upside down assembly Montaggio invertito	Einbaulage Überkopf Upside down assembly Montaggio invertito	Einbaulage Überkopf Upside down assembly Montaggio invertito	Einbaulage Überkopf Upside down assembly Montaggio invertito

Hinweis: Sonderabmessungen und Abstechhalter für andere Maschinenhersteller auf Anfrage erhältlich. Ein Anfrageblatt hierzu finden Sie auf Seite 578 oder im Internet unter: www.arno.de/service/downloads

Remark: Custom made part-off holders for other machine manufacturers are available on request. Please complete enquiry sheet on page 578 or download this from www.arno.de/service/downloads

Nota: Adattatori speciali di differenti dimensioni e caratteristiche disponibili a richiesta. Vedere modulo richiesta a Pagina 578 o download del modulo da: www.arno.de/service/downloads

--> Anwendungshinweise finden Sie auf S. 582
 --> For application reference please see page 582
 --> Per suggerimenti tecnici vedere pagina 582

VDI25 / MSA-I - mit Innenkühlung und ACS

VDI25 / MSA-I - with internal coolant and ACS

VDI25 / MSA-I - con refrigerazione interna e ACS

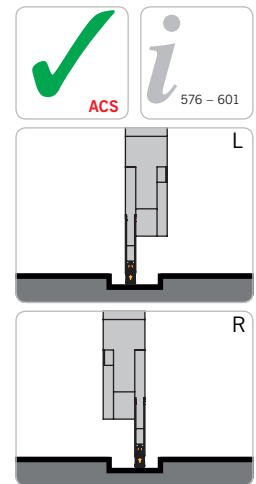
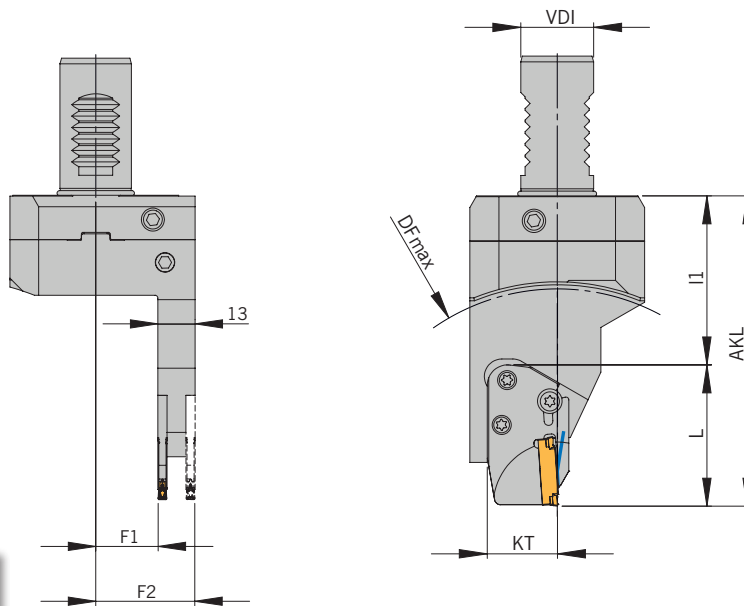

Rechter Halter und
linkes Modul montiert
Halter höhenstellbar
Rechtes Modul alternativ
Right holder and left module shown
Height adjustable holder
Right module alternative
Adattatore destro e
modulo sinistro in figura
Adattatore registrabile in altezza
Modulo destro alternativa



Grundhalter / Basic holder / Adattore

Bezeichnung Designation Articolo	VDI	L1	F1	F2	KT	Modul Module Modulo	PG 43
HVDI 25R-7-22-D-MSA-I-ACS	25	58	23,4	33,2	24	MSA-I-...-ACS.	●

Modul / Module / Modulo

DF_{max} = Maximaler Futterdurchmesser und $AKL = L$ (Länge des Moduls) + $L1$ / DF_{max} = maximum chuck diameter and $AKL = L$ (length of module) + $L1$ / DF_{max} = Diametro max mandrino e $AKL = L$ (lunghezza modulo) + $L1$

Bezeichnung Designation Articolo	VDI25...	AKL	DF_{max}
MSA-I.-L37-...-ACS.		95,0	125
MSA-I.-L41-...-ACS.		99,0	130
MSA-I.-L43,5-...-ACS.		101,5	135
MSA-I.-L44-...-ACS.		102,0	135
MSA-I.-L45,5-...-ACS.		103,5	140
MSA-I.-L48,5-...-ACS.		106,5	145

Hinweis: Passende Module finden Sie im Kapitel SA (Seite 114 bis 128)

Remark: For modules to suit please see chapter SA (Page 114 to 128)

Nota: Per I moduli abbinabili vedere pagine da 114 a 128

Ersatzteile / Spare Parts / Ricambi

Trägerwerkzeug Holder Utensile	Zylinderkopfschraube Cylinder head screw Vite a testa cilindrica	O-Ring O-ring O-Ring	O-Ring 2 O-ring 2 O-Ring 2
HVDI 25R-..	DIN912-M3X3-A2	OR 8X1-NBR70	OR 23,6X1,8-NBR70

Ersatzteile / Spare Parts / Ricambi

Modul Module Modulo	Zylinderkopfschraube Cylinder head screw Vite a testa cilindrica	Schlüssel Key Chiave
MSA-I.-...-ACS.	2 x AS 0049/1 x AS 0050*	T5220-IP

* Alternativ AS 0050 D (doppelseitig, IP20)

* Alternatively AS 0050D (double sided IP20)

* Alternativo AS 0050D (bilateralmente IP20)

Einbaumöglichkeiten / Assembly options / Combinazioni di montaggio

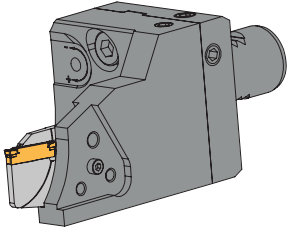
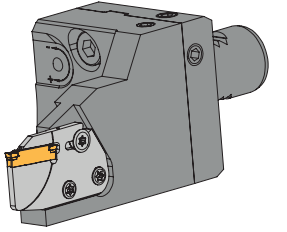
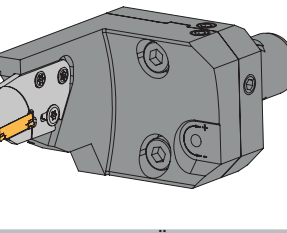
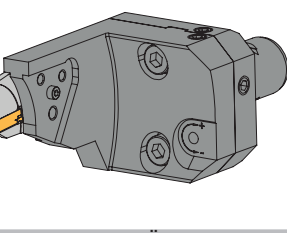
<p>Linkes Modul montiert <i>Left module shown</i> Modulo sinistro in figura</p>	<p>Rechtes Modul montiert <i>Right module shown</i> Modulo destro in figura</p>
	
<p>Einbaulage normal <i>Normal assembly</i> Montaggio normale</p>	<p>Einbaulage normal <i>Normal assembly</i> Montaggio normale</p>
	
<p>Einbaulage Überkopf <i>Upside down assembly</i> Montaggio invertito</p>	<p>Einbaulage Überkopf <i>Upside down assembly</i> Montaggio invertito</p>

Hinweis: Mit einem Halter sind alle abgebildeten Varianten montierbar.

Remark: All shown options are available with only one holder.

Nota: E' sufficiente un solo corpo base per comporre tutte le combinazioni raffigurate.

Hinweis: Sonderabmessungen und Abstechhalter für andere Maschinenhersteller auf Anfrage erhältlich. Ein Anfrageblatt hierzu finden Sie auf Seite 578 oder im Internet unter: www.arno.de/service/downloads

Remark: Custom made part-off holders for other machine manufacturers are available on request.

Please complete enquiry sheet on page 578 or download this from www.arno.de/service/downloads

Nota: Adattatori speciali di differenti dimensioni e caratteristiche disponibili a richiesta.

Vedere modulo richiesta a Pagina 578 o download del modulo da: www.arno.de/service/downloads

--> **Anwendungshinweise finden Sie auf S. 582/600/601**

--> *For application reference please see page 582/600/601*

--> *Per suggerimenti tecnici vedere pagina 582/600/601*

Abstechhalter - MSA

Part-off holder - MSA
 Attacchi base - MSA

Abstechhalter und Direktaufnahmen

Part-off holders and flange mounted holders
 Adattatori di troncatura e attacchi base

VDI25 - mit Innenkühlung, ACS und W-Verzahnung

VDI25 - with internal coolant, ACS and W-notch

VDI25 - con refrigerazione interna, ACS e piano tipo W

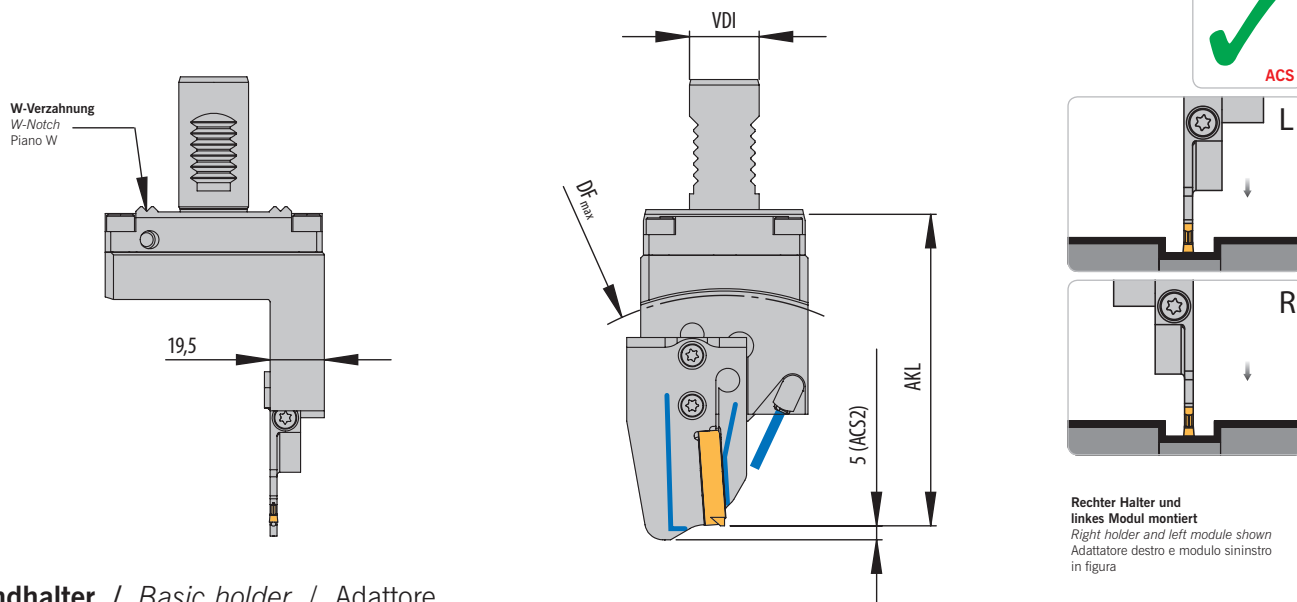

Grundhalter / Basic holder / Adattore

Bezeichnung Designation Articolo	VDI	F1	Modul Module Modulo	PG 43
HVDI 25WL-7-20-MSA-SR	25	20	MSA-SR-...-ACS.	●
HVDI 25WR-7-20-MSA-SL	25	20	MSA-SL-...-ACS.	●

Modul / Module / Modulo

DF_{max} = Maximaler Futterdurchmesser und AKL = Auskräglänge bei Modul MSA-... / DF_{max} = maximum chuck diameter and AKL = Overhang length with modules MSA-... / DF_{max} = Diametro max mandrino e AKL = Lunghezza totale con modulo MSA-...

Bezeichnung Designation Articolo	AKL	DF _{max}
MSA-...-32-ACS.	96,5	135
MSA-...-44-ACS.	101,5	145
MSA-...-52-ACS.	112,0	165
MSA-...-65-ACS.	112,0	165
MSA-...-69-ACS.	114,0	170
MSA-...-80-ACS.	119,5	180
MSA-...-90-ACS.	124,5	190
MSA-...-105-ACS.	132,0	205

Hinweis: Passende Module finden Sie im Kapitel SA (Seite 114 bis 128)

Remark: For modules to suit please see chapter SA (Page 114 to 128)

Nota: Per i moduli abbinabili vedere pagine da 114 a 128

Ersatzteile / Spare Parts / Ricambi

Trägerwerkzeug Holder Utensile	Schraube für Modul Screw for module Vite per modulo	Schlüssel Key Chiave	O-Ring O-ring O-Ring	Kühlmitteldüse Coolant jet Ugello refrigerante	Verschluss-Stift Locking pin Spina bloccaggio
HVDI 25W.-	AS 0070	T5220-IP	OR 23,6X1,8-NBR80*	KMD 0820-4BJ	ZS0820G

* Nicht im Lieferumfang enthalten.

* Not included in the delivery.

* Non incluso.

Ersatzteile / Spare Parts / Ricambi

Modul Module Modulo	Schraube für Modul Screw for module Vite per modulo	Schlüssel Key Chiave
MSA-...-	SA5T	T5220-IP

Einbaumöglichkeiten / Assembly options / Combinazioni di montaggio

Linker Halter Left-hand holder Adattatore sinistro	Rechter Halter Right-hand holder Adattatore destro
HVDI 25WL-7-20-MSA-SR	HVDI 25WR-7-20-MSA-SL
Rechtes Modul montiert Right module shown Modulo destro in figura	Linkes Modul montiert Left module shown Modulo sinistro in figura
Einbaulage normal Normal assembly Montaggio normale	Einbaulage normal Normal assembly Montaggio normale
Einbaulage Überkopf Upside down assembly Montaggio invertito	Einbaulage Überkopf Upside down assembly Montaggio invertito

Hinweis: Sonderabmessungen und Abstechhalter für andere Maschinenhersteller auf Anfrage erhältlich. Ein Anfrageblatt hierzu finden Sie auf Seite 578 oder im Internet unter: www.arno.de/service/downloads

Remark: Custom made part-off holders for other machine manufacturers are available on request. Please complete enquiry sheet on page 578 or download this from www.arno.de/service/downloads

Nota: Adattatori speciali di differenti dimensioni e caratteristiche disponibili a richiesta. Vedere modulo richiesta a Pagina 578 o download del modulo da: www.arno.de/service/downloads

--> Anwendungshinweise finden Sie auf S. 582
 --> For application reference please see page 582
 --> Per suggerimenti tecnici vedere pagina 582

VDI25 - mit Innenkühlung, ACS und W-Verzahnung

VDI25 - with internal coolant, ACS and W-notch

VDI25 - con refrigerazione interna, ACS e piano tipo W

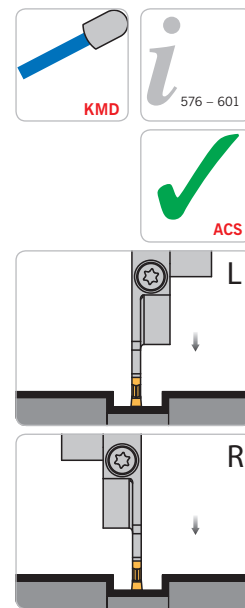
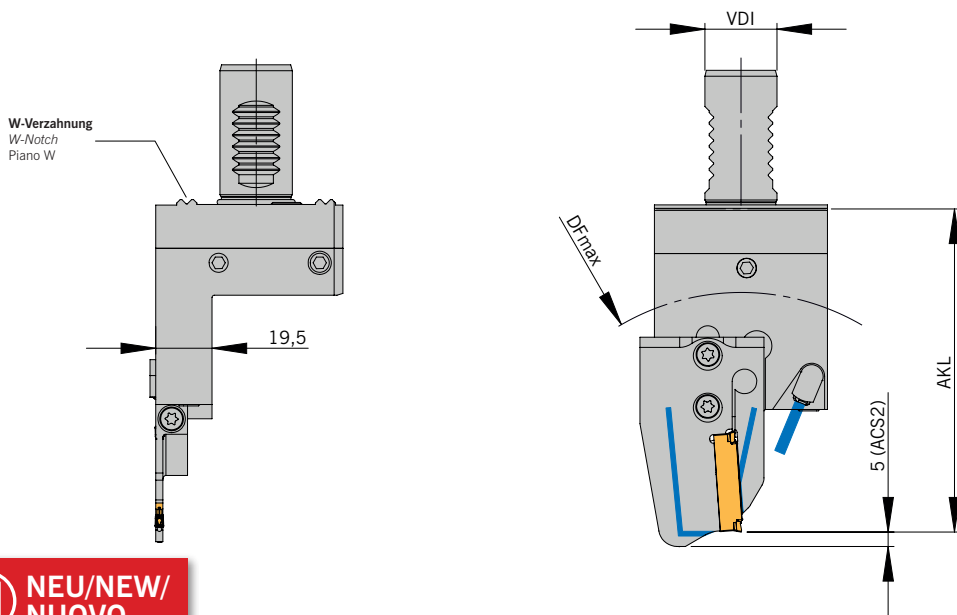

Linker Halter und Linkes Modul montiert
Halter höhenstellbar
Left holder and left module show
Height adjustable holder
Adattatore sinistro e Modulo sinistro in figura
Adattatore registrabile in altezza



Grundhalter / Basic holder / Adattore

Bezeichnung Designation Articolo	VDI	F2	Modul Module Modulo	PG 43
HVDI 25WL-7-35-MSA-SL	25	35	MSA-SL...-ACS.	●
HVDI 25WR-7-35-MSA-SR	25	35	MSA-SR...-ACS.	●

Modul / Module / Modulo

DF_{max} = Maximaler Futterdurchmesser und AKL = Auskraglänge bei Modul MSA-... / DF_{max} = maximum chuck diameter and AKL = Overhang length with modules MSA-... / DF_{max} = Diametro max mandrino e AKL = Lunghezza totale con modulo MSA-..

Bezeichnung Designation Articolo	VDI25W	
	AKL	DF_{max}
MSA-...-32-ACS.	96,5	135
MSA-...-44-ACS.	101,5	145
MSA-...-52-ACS.	112,0	165
MSA-...-65-ACS.	112,0	165
MSA-...-69-ACS.	114,0	170
MSA-...-80-ACS.	119,5	180
MSA-...-90-ACS.	124,5	190
MSA-...-105-ACS.	132,0	205

Hinweis: Passende Module finden Sie im Kapitel SA (Seite 114 bis 128)

Remark: For modules to suit please see chapter SA (Page 114 to 128)

Nota: Per i moduli abbinabili vedere pagine da 114 a 128

Ersatzteile / Spare Parts / Ricambi

Trägerwerkzeug Holder Utensile	Schraube für Modul Screw for module Vite per modulo	Schlüssel Key Chiave	O-Ring O-ring O-Ring	Kühlmitteldüse Coolant jet Ugello refrigerante	Verschluss-Stift Locking pin Spina bloccaggio
HVDI 25W.-	AS 0070	T5220-IP	OR 23,6X1,8-NBR80*	KMD 0820-4BJ	ZS0820G

* Nicht im Lieferumfang enthalten.





* Not included in the delivery.

* Non incluso.

Ersatzteile / Spare Parts / Ricambi

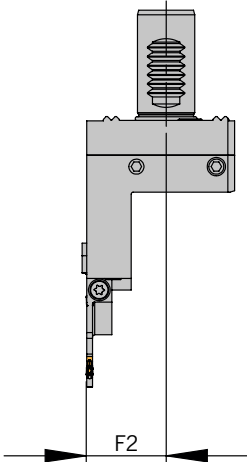
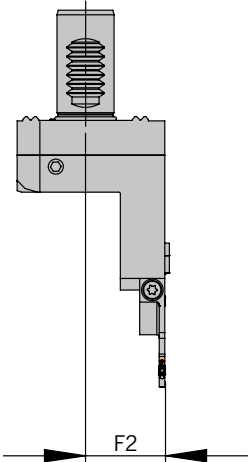
Modul Module Modulo	Schraube für Modul Screw for module Vite per modulo	Schlüssel Key Chiave
MSA-...-	SA5T	T5220-IP

Einbaumöglichkeiten / Assembly options / Combinazioni di montaggio

Linker Halter Left-hand holder Adattatore sinistro	Rechter Halter Right-hand holder Adattatore destro
HVDI 25WL-7-35-MSA-SL	HVDI 25WR-7-35-MSA-SR
	
Linkes Modul montiert Left module shown Modulo sinistro in figura	Rechtes Modul montiert Right module shown Modulo destro in figura
	
Einbaulage normal Normal assembly Montaggio normale	Einbaulage normal Normal assembly Montaggio normale
	
Einbaulage Überkopf Upside down assembly Montaggio invertito	Einbaulage Überkopf Upside down assembly Montaggio invertito

Hinweis: Sonderabmessungen und Abstechhalter für andere Maschinenhersteller auf Anfrage erhältlich. Ein Anfrageblatt hierzu finden Sie auf Seite 578 oder im Internet unter: www.arno.de/service/downloads

Remark: Custom made part-off holders for other machine manufacturers are available on request. Please complete enquiry sheet on page 578 or download this from www.arno.de/service/downloads

Nota: Adattatori speciali di differenti dimensioni e caratteristiche disponibili a richiesta. Vedere modulo richiesta a Pagina 578 o download del modulo da: www.arno.de/service/downloads

--> Anwendungshinweise finden Sie auf S. 582
 --> For application reference please see page 582
 --> Per suggerimenti tecnici vedere pagina 582

VDI30 - mit Innenkühlung / VDI30 - with internal coolant / VDI30 - con refrigerazione interna

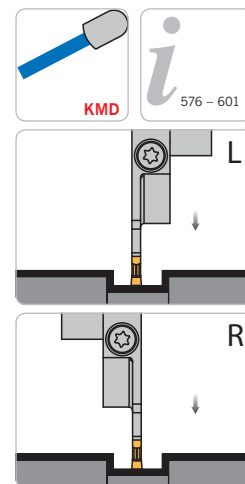
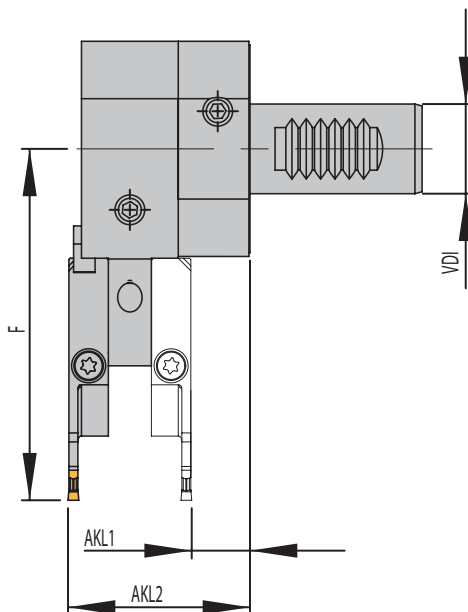
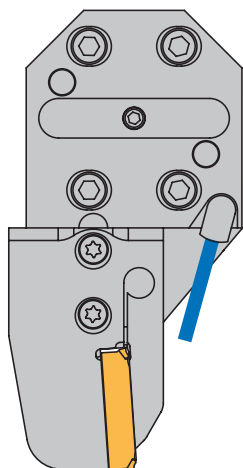

Linkes Modul montiert
 Halter höhenstellbar
 Rechtes Modul alternativ
 Left module shown
 Height adjustable holder
 right module alternative
 Modulo sinistro in figura
 Adattatore registrabile in altezza
 Modulo destro alternativa

Grundhalter / Basic holder / Adattore

Bezeichnung Designation Articolo	VDI	AKL1	AKL2	Modul Module Modulo	PG 43
HVDS 30-1	30	16,3	50,8	MSA-...	●

Modul / Module / Modulo

F = Maße bei Modul MSA-... / F = dimension of Modul MSA-... / F = Lunghezza con modulo MSA-...

Bezeichnung Designation Articolo	VDI30...
	F
MSA-...-32	86,0
MSA-...-44	91,0
MSA-...-52	101,5
MSA-...-65	101,5
MSA-...-80	109,0
MSA-...-105	122,0
MSA-...-125	132,0
MSA-...-140	139,5

Hinweis: Passende Module finden Sie im Kapitel SA (Seite 114 bis 128)

Remark: For modules to suit please see chapter SA (Page 114 to 128)

Nota: Per I moduli abbinabili vedere pagine da 114 a 128

Ersatzteile / Spare Parts / Ricambi





Trägerwerkzeug Holder Utensile	Schraube für Modul Screw for module Vite per modulo	Schlüssel Key Chiave	Kühlmitteldüse Coolant jet Ugello refrigerante
HVDS 30-1	AS 0070	T5220-IP	KMD 0825-3E

Ersatzteile / Spare Parts / Ricambi

Modul Module Modulo	Schraube für Modul Screw for module Vite per modulo	Schlüssel Key Chiave
MSA-...	SA5T	T5220-IP



Einbaumöglichkeiten / Assembly options / Combinazioni di montaggio

<p>Linkes Modul montiert <i>Left module shown</i> Modulo sinistro in figura</p>	<p>Rechtes Modul montiert <i>Right module shown</i> Modulo destro in figura</p>
	
<p>Einbaulage normal <i>Normal assembly</i> Montaggio normale</p>	<p>Einbaulage normal <i>Normal assembly</i> Montaggio normale</p>
	
<p>Einbaulage Überkopf <i>Upside down assembly</i> Montaggio invertito</p>	<p>Einbaulage Überkopf <i>Upside down assembly</i> Montaggio invertito</p>

Hinweis: Mit einem Halter sind alle abgebildeten Varianten montierbar.

Remark: All shown options are available with only one holder.

Nota: E' sufficiente un solo corpo base per comporre tutte le combinazioni raffigurate.

Hinweis: Sonderabmessungen und Abstechhalter für andere Maschinenhersteller auf Anfrage erhältlich. Ein Anfrageblatt hierzu finden Sie auf Seite 578 oder im Internet unter: www.arno.de/service/downloads

Remark: Custom made part-off holders for other machine manufacturers are available on request.

Please complete enquiry sheet on page 578 or download this from www.arno.de/service/downloads

Nota: Adattatori speciali di differenti dimensioni e caratteristiche disponibili a richiesta.

Vedere modulo richiesta a Pagina 578 o download del modulo da: www.arno.de/service/downloads

--> **Anwendungshinweise finden Sie auf S. 584/585**

--> *For application reference please see page 584/585*

--> *Per suggerimenti tecnici vedere pagina 584/585*

VDI30 - mit Innenkühlung und ACS / VDI30 - with internal coolant and ACS / VDI30 - con refrigerazione interna e ACS

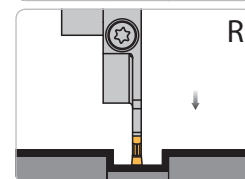
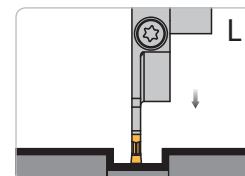
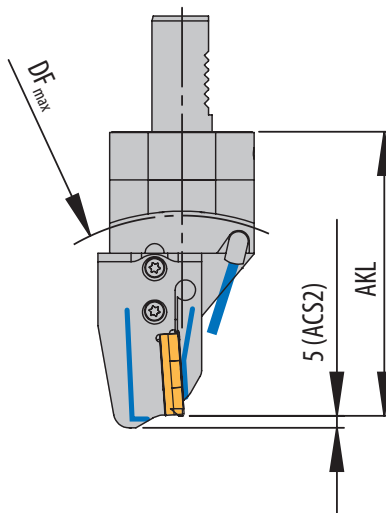
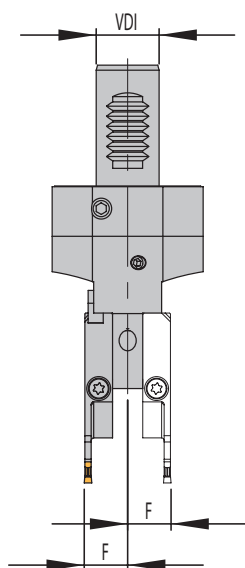

Linkes Modul montiert
Halter höhenstellbar
Rechtes Modul alternativ
Left module shown
Height adjustable holder
Right module alternative
Modulo sinistro in figura
Adattatore registrabile in altezza
Modulo destro alternativa

Grundhalter / Basic holder / Adattore

Bezeichnung Designation Articolo	VDI	F	Modul Module Modulo	PG 43
HVDS 30-7-ACS	30	17,3	MSA-...-ACS.	●

Modul / Module / Modulo

DF_{max} = Maximaler Futterdurchmesser und AKL = Auskräglänge bei Modul MSA-... / DF_{max} = maximum chuck diameter and AKL = Overhang length with modules MSA-... / DF_{max} = Diametro max mandrino e AKL = Lunghezza totale con modulo MSA-...

Bezeichnung Designation Articolo	VDI30...	
	AKL	DF_{max}
MSA-...-32-ACS.	109,0	145
MSA-...-44-ACS.	114,0	155
MSA-...-52-ACS.	124,5	180
MSA-...-65-ACS.	124,5	180
MSA-...-69-ACS.	126,5	180
MSA-...-80-ACS.	132,0	190
MSA-...-90-ACS.	137,0	200
MSA-...-105-ACS.	145,0	215

Hinweis: Passende Module finden Sie im Kapitel SA (Seite 114 bis 128)

Remark: For modules to suit please see chapter SA (Page 114 to 128)

Nota: Per i moduli abbinabili vedere pagine da 114 a 128





Ersatzteile / Spare Parts / Ricambi

Trägerwerkzeug Holder Utensile	Schraube für Modul Screw for module Vite per modulo	Schlüssel Key Chiave	O-Ring O-ring O-Ring	Kühlmitteldüse Coolant jet Ugello refrigerante
HVDS 30-7-ACS	AS 0070	T5220-IP	OR 28X1,8-NBR80	KMD 0825-3E

Ersatzteile / Spare Parts / Ricambi

Modul Module Modulo	Schraube für Modul Screw for module Vite per modulo	Schlüssel Key Chiave
MSA-...-	SA5T	T5220-IP

Einbaumöglichkeiten / Assembly options / Combinazioni di montaggio

Linkes Modul montiert <i>Left module shown</i> Modulo sinistro in figura	Rechtes Modul montiert <i>Right module shown</i> Modulo destro in figura
	
Einbaulage normal <i>Normal assembly</i> Montaggio normale	Einbaulage normal <i>Normal assembly</i> Montaggio normale
	
Einbaulage Überkopf <i>Upside down assembly</i> Montaggio invertito	Einbaulage Überkopf <i>Upside down assembly</i> Montaggio invertito

Hinweis: Mit einem Halter sind alle abgebildeten Varianten montierbar.

Remark: All shown options are available with only one holder.

Nota: E' sufficiente un solo corpo base per comporre tutte le combinazioni raffigurate.

Hinweis: Sonderabmessungen und Abstechhalter für andere Maschinenhersteller auf Anfrage erhältlich. Ein Anfrageblatt hierzu finden Sie auf Seite 578 oder im Internet unter: www.arno.de/service/downloads

Remark: Custom made part-off holders for other machine manufacturers are available on request. Please complete enquiry sheet on page 578 or download this from www.arno.de/service/downloads

Nota: Adattatori speciali di differenti dimensioni e caratteristiche disponibili a richiesta.

Vedere modulo richiesta a Pagina 578 o download del modulo da: www.arno.de/service/downloads

--> **Anwendungshinweise finden Sie auf S. 584/585**

--> *For application reference please see page 584/585*

--> *Per suggerimenti tecnici vedere pagina 584/585*

Abstechhalter - MSA

Part-off holder - MSA
Attacchi base - MSA

Abstechhalter und Direktaufnahmen

Part-off holders and flange mounted holders
Adattatori di troncatura e attacchi base

VDI30 - mit Innenkühlung und ACS / VDI30 - with internal coolant and ACS / VDI30 - con refrigerazione interna e ACS

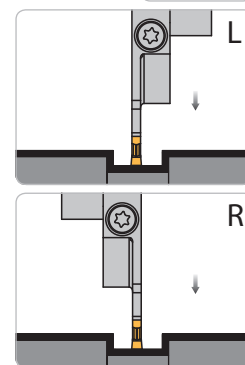
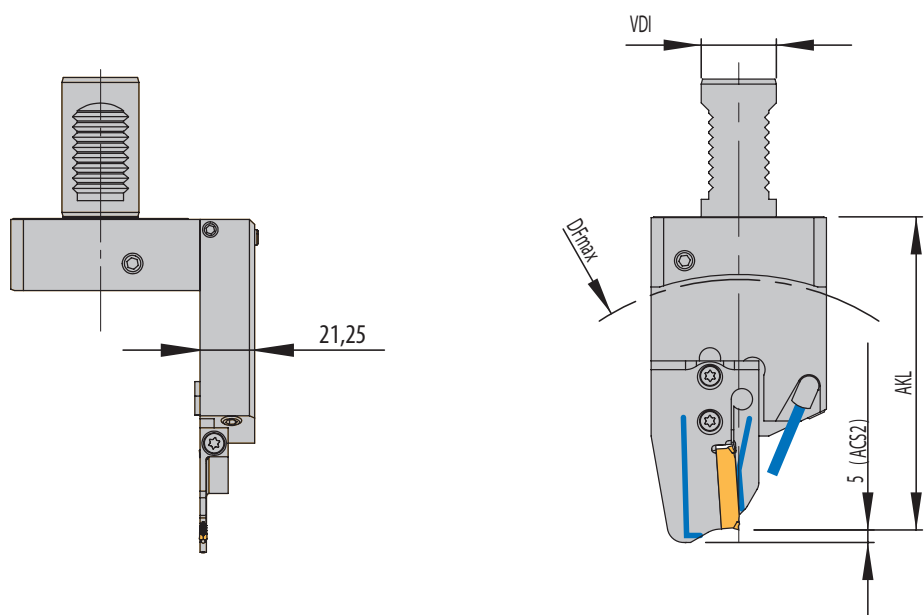

Rechter Halter und linkes Modul montiert
Halter höhenstellbar
Right holder and left module shown
Height adjustable holder
Adattatore destro e Modulo sinistro in figura
Adattatore registrabile in altezza

Grundhalter / Basic holder / Adattore

Bezeichnung Designation Articolo	VDI	F1	F2	Modul Module Modulo	PG 43
HVDI 30L-7-38-MSA-SR	30	38,5	-	MSA-SR...-ACS.	●
HVDI 30L-7-60-MSA-SL	30	-	60,3	MSA-SL...-ACS.	●
HVDI 30R-7-38-MSA-SL	30	38,5	-	MSA-SL...-ACS.	●
HVDI 30R-7-60-MSA-SR	30	-	60,3	MSA-SR...-ACS.	●
HVDI 30L-7-38-107-MSA-SR	30	38,5	-	MSA-SR...-ACS.	●
HVDI 30L-7-60-107-MSA-SL	30	-	60,3	MSA-SL...-ACS.	●
HVDI 30R-7-38-107-MSA-SL	30	38,5	-	MSA-SL...-ACS.	●
HVDI 30R-7-60-107-MSA-SR	30	-	60,3	MSA-SR...-ACS.	●

Modul / Module / Modulo

DF_{max} = Maximaler Futterdurchmesser und AKL = Auskraglänge bei Modul MSA-... / DF_{max} = maximum chuck diameter and AKL = Overhang length with modules MSA-... / DF_{max} = Diametro max mandrino e AKL = Lunghezza totale con modulo MSA-...

Bezeichnung Designation Articolo	VDI30...		VDI30...-107	
	AKL	DF_{max}	AKL	DF_{max}
MSA-...-105-ACS.	145,5	235	127,5	200
MSA-...-32-ACS.	109,5	165	91,5	130
MSA-...-44-ACS.	114,5	175	96,5	140
MSA-...-52-ACS.	125,0	200	107,0	160
MSA-...-65-ACS.	125,0	200	107,0	160
MSA-...-69-ACS.	127,0	200	109,0	165
MSA-...-80-ACS.	132,5	210	114,5	175
MSA-...-90-ACS.	137,5	220	119,5	185

Hinweis: Passende Module finden Sie im Kapitel SA (Seite 114 bis 128)

Remark: For modules to suit please see chapter SA (Page 114 to 128)

Nota: Per i moduli abbinabili vedere pagine da 114 a 128

Ersatzteile / Spare Parts / Ricambi

Trägerwerkzeug Holder Utensile	Schraube für Modul Screw for module Vite per modulo	Schlüssel Key Chiave	O-Ring O-ring O-Ring	Kühlmitteldüse Coolant jet Ugello refrigerante	Verschluss-Stift Locking pin Spina bloccaggio
HVDI 30.-	AS 0070	T5220-IP	OR 28X1,8-NBR80	KMD 0820-4BJ	ZS0820G

Ersatzteile / Spare Parts / Ricambi

Modul Module Modulo	Schraube für Schneideinsatz Screw for insert Vite per sede inserti	Schlüssel Key Chiave
MSA-...-	SA5T	T5220-IP

Einbaumöglichkeiten / Assembly options / Combinazioni di montaggio

Linker Halter Left-hand holder Adattatore sinistro		Rechter Halter Right-hand holder Adattatore destro	
HVDI 30L-7-28-MSA-SL	HVDI 30L-7-38-MSA-SR	HVDI 30R-7-60-MSA-SL	HVDI 30R-7-60-MSA-SR
HVDI 30L-7-38-107-MSA-SL	HVDI 30L-7-28-107-MSA-SR	HVDI 30R-7-60-107-MSA-SL	HVDI 30R-7-60-107-MSA-SR
Linkes Modul montiert Left module shown Modulo sinistro in figura	Rechtes Modul montiert Right module shown Modulo destro in figura	Linkes Modul montiert Left module shown Modulo sinistro in figura	Rechtes Modul montiert Right module shown Modulo destro in figura
Einbaulage normal Normal assembly Montaggio normale	Einbaulage normal Normal assembly Montaggio normale	Einbaulage normal Normal assembly Montaggio normale	Einbaulage normal Normal assembly Montaggio normale
Einbaulage Überkopf Upside down assembly Montaggio invertito	Einbaulage Überkopf Upside down assembly Montaggio invertito	Einbaulage Überkopf Upside down assembly Montaggio invertito	Einbaulage Überkopf Upside down assembly Montaggio invertito

Hinweis: Sonderabmessungen und Abstechhalter für andere Maschinenhersteller auf Anfrage erhältlich.
Ein Anfrageblatt hierzu finden Sie auf Seite 578 oder im Internet unter: www.arno.de/service/downloads

Remark: Custom made part-off holders for other machine manufacturers are available on request.
 Please complete enquiry sheet on page 578 or download this from www.arno.de/service/downloads

Nota: Adattatori speciali di differenti dimensioni e caratteristiche disponibili a richiesta.
 Vedere modulo richiesta a Pagina 578 o download del modulo da: www.arno.de/service/downloads

--> Anwendungshinweise finden Sie auf S. 583
 --> For application reference please see page 583
 --> Per suggerimenti tecnici vedere pagina 583

VDI30 - mit Innenkühlung und ACS für KSA-Steckklingen

VDI30 - with internal coolant and ACS for KSA blades

VDI30 - con refrigerazione interna e ACS per lame KSA

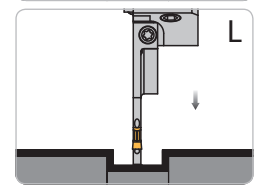
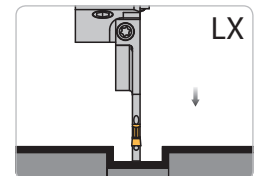
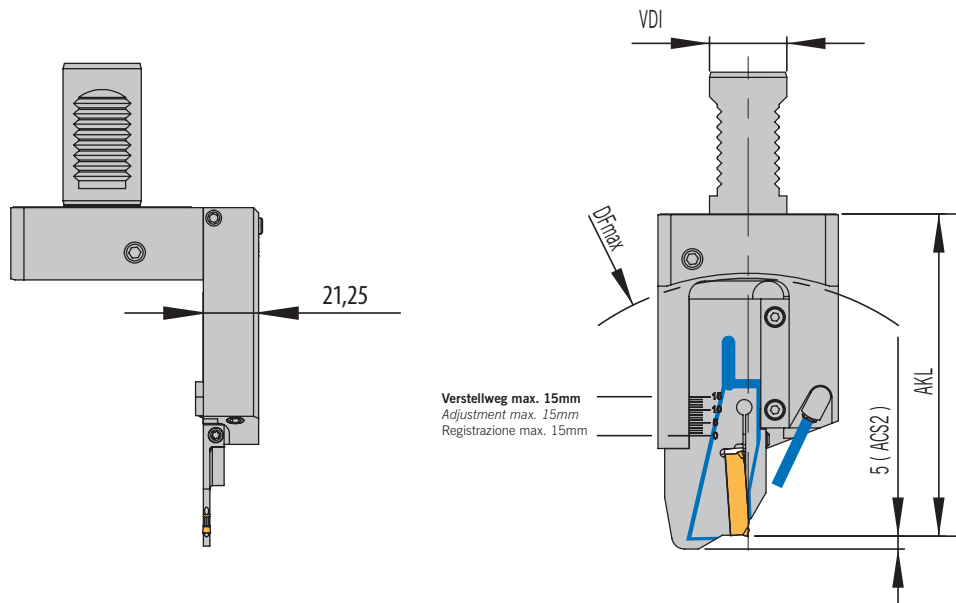

Rechter Halter und Klinge L montiert
Halter höhenstellbar
Right holder and blade L fixed
Height adjustable holder
Adattatore destro e lama L montata
Adattatore registrabile in altezza

Grundhalter / Basic holder / Adattore

Bezeichnung Designation Articolo	VDI	F1	F2	Klinge Blade Lama	PG 43
HVDI 30L-7-38-KSA-32LX	30	38,5	-	KSA 3208LX...ACS.	●
HVDI 30L-7-60-KSA-32L	30	-	60,3	KSA 3208L...ACS.	●
HVDI 30R-7-38-KSA-32L	30	38,5	-	KSA 3208L...ACS.	●
HVDI 30R-7-60-KSA-32LX	30	-	60,3	KSA 3208LX...ACS.	●

Hinweis für Klinge „LX“ und Klinge „L“: Zur optimalen Gewährleistung der Kühlung darf die Klinge max. 15 mm ausgespannt werden.

Remark for blade „L“ and „LX“: For optimum coolant flow the blade should not exceed a 15 mm overhang.

Nota per lame „L“ ed „LX“: Per una ottimale adduzione del refrigerante la lama non deve sporgere oltre i 15 mm.

Steckklinge / Part-off blade / Lama da taglio

DF_{max} = Maximaler Futterdurchmesser und AKL = Auskraglänge bei Klinge KSA-... / DF_{max} = maximum chuck diameter and AKL = Overhang length with blades KSA-.. / DF_{max} = Diametro max mandrino e AKL = Lunghezza totale con lame KSA-..

Bezeichnung Designation Articolo	VDI30...	
	AKL	$DF_{max}^{1)}$
KSA-...-44-ACS.	114,5	177
KSA-...-65-ACS.	125,0	198

1) Formel für DF_{max} bei variabler Auskraglänge der Klinge: $DF_{max} (AKL_{min} - 26 + Verstellweg) \times 2$

1) Formula for DF_{max} for variable overhang of blade: $DF_{max} (AKL_{min} - 26 + adjustment) \times 2$

1) Formula per DF_{max} in funzione della sporgenza lama: $DF_{max} (AKL_{min} - 26 + corsa) \times 2$

Hinweis: Passende Klingen finden Sie im Kapitel SA (Seite 94 bis 111)

Remark: For blades to suit please see chapter SA (Page 94 to 111)

Nota: Per l lame abbinabili vedere pagine da 94 a 111







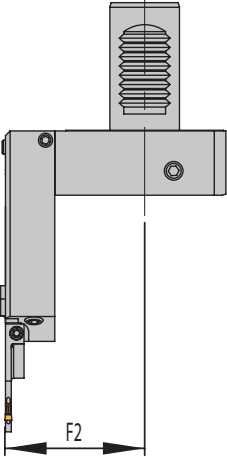
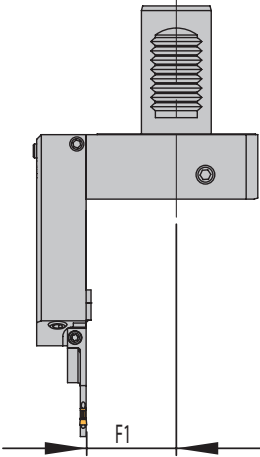
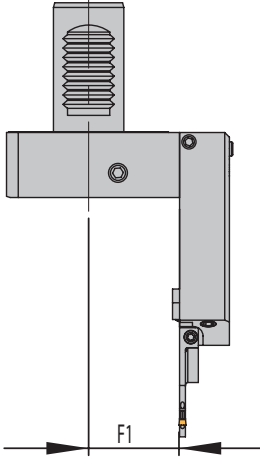
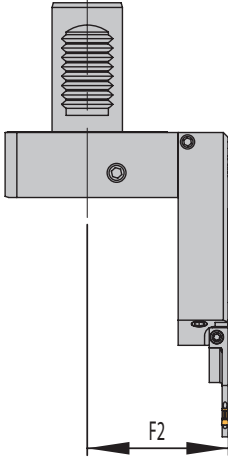

Ersatzteile / Spare Parts / Ricambi

Trägerwerkzeug Holder Utensile	Spannschraube für Klemme Span screw for clamp Vite di arco per staffa	Klemme Clamp Staffa	Kühlmitteldüse Coolant jet Ugello refrigerante	Verschluss-Stift Locking pin Spina bloccaggio	O-Ring O-ring O-Ring
HVDI 30-...-KSA-..	DIN912-M4X12-12.9	K-HVDI-10-50	KMD 0820-4BJ	ZS0820G	OR 28X1,8-NBR80

Ersatzteile / Spare Parts / Ricambi

Klinge Blade Lama	Spannschraube für Schneideinsatz Span screw for insert Vite di arco per inserti	Schlüssel Key Chiave
KSA 3208.	AS 0022	T5115-IP

Einbaumöglichkeiten / Assembly options / Combinazioni di montaggio

Linker Halter Left-hand holder Adattatore sinistro		Rechter Halter Right-hand holder Adattatore destro	
HVDI 30L-7-60-KSA-32L	HVDI 30L-7-38-KSA-32LX	HVDI 30R-7-38-KSA-32L	HVDI 30R-7-60-KSA-32LX
			
Klinge L montiert Blade L shown Lama L in figura	Klinge LX montiert Blade LX shown Lama LX in figura	Klinge L montiert Blade L shown Lama L in figura	Klinge LX montiert Blade LX shown Lama LX in figura
			
Einbaulage normal Normal assembly Montaggio normale	Einbaulage normal Normal assembly Montaggio normale	Einbaulage normal Normal assembly Montaggio normale	Einbaulage normal Normal assembly Montaggio normale
			
Einbaulage Überkopf Upside down assembly Montaggio invertito	Einbaulage Überkopf Upside down assembly Montaggio invertito	Einbaulage Überkopf Upside down assembly Montaggio invertito	Einbaulage Überkopf Upside down assembly Montaggio invertito

**Hinweis: Sonderabmessungen und Abstechhalter für andere Maschinenhersteller auf Anfrage erhältlich.
Ein Anfrageblatt hierzu finden Sie auf Seite 578 oder im Internet unter: www.arno.de/service/downloads**

*Remark: Custom made part-off holders for other machine manufacturers are available on request.
Please complete enquiry sheet on page 578 or download this from www.arno.de/service/downloads*

*Nota: Adattatori speciali di differenti dimensioni e caratteristiche disponibili a richiesta.
Vedere modulo richiesta a Pagina 578 o download del modulo da: www.arno.de/service/downloads*

--> Anwendungshinweise finden Sie auf S. 583
--> For application reference please see page 583
--> Per suggerimenti tecnici vedere pagina 583

VDI30 - mit Innenkühlung, ACS und W-Verzahnung

VDI30 - with internal coolant, ACS and W-notch

VDI30 - con refrigerazione interna, ACS e piano tipo W

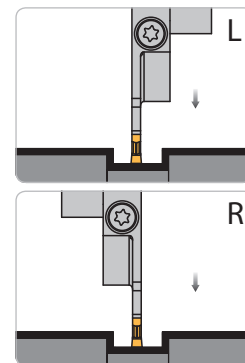
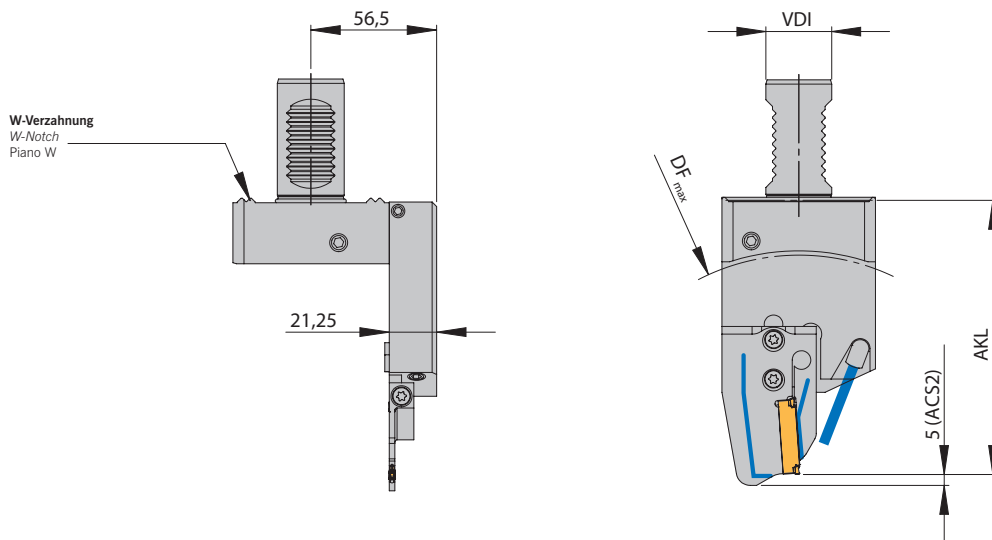

Rechter Halter und linkes Modul montiert
Halter höhenstellbar
Right holder and left module shown
Height adjustable holder
Adattatore destro e modulo sinistro in figura
Adattatore regolabile in altezza

Grundhalter / Basic holder / Adattore

Bezeichnung Designation Articolo	VDI	F1	Modul Module Modulo	PG 43
HVDI 30WL-7-35-MSA-SR	30	35	MSA-SR...-ACS.	●
HVDI 30WR-7-35-MSA-SL	30	35	MSA-SL...-ACS.	●

Modul / Module / Modulo

DF_{max} = Maximaler Futterdurchmesser und AKL = Auskräglänge bei Modul MSA-... / DF_{max} = maximum chuck diameter and AKL = Overhang length with modules MSA-... / DF_{max} = Diametro max mandrino e AKL = Lunghezza totale con modulo MSA-...

Bezeichnung Designation Articolo	VDI30W...	
	AKL	DF_{max}
MSA-...-32-ACS.	109,5	165
MSA-...-44-ACS.	114,5	175
MSA-...-52-ACS.	125,0	200
MSA-...-65-ACS.	125,0	200
MSA-...-69-ACS.	127,0	200
MSA-...-80-ACS.	132,5	210
MSA-...-90-ACS.	137,5	220
MSA-...-105-ACS.	145,5	235

Hinweis: Passende Module finden Sie im Kapitel SA (Seite 114 bis 128)

Remark: For modules to suit please see chapter SA (Page 114 to 128)

Nota: Per i moduli abbinabili vedere pagine da 114 a 128

Ersatzteile / Spare Parts / Ricambi

Trägerwerkzeug Holder Utensile	Schraube für Modul Screw for module Vite per modulo	Schlüssel Key Chiave	O-Ring O-ring O-Ring	Kühlmitteldüse Coolant jet Ugello refrigerante	Verschluss-Stift Locking pin Spina bloccaggio
HVDI 30W.-	AS 0070	T5220-IP	OR 23,6X1,8-NBR80*	KMD 0820-4BJ	ZS0820G

* Nicht im Lieferumfang enthalten.





* Not included in the delivery.

* Non incluso.

Ersatzteile / Spare Parts / Ricambi

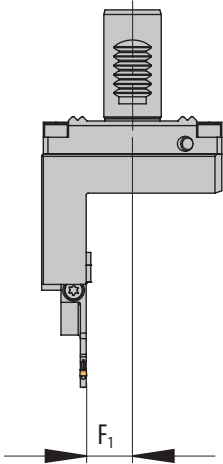
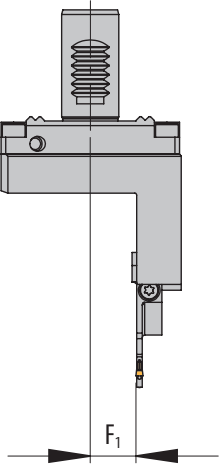
Modul Module Modulo	Schraube für Modul Screw for module Vite per modulo	Schlüssel Key Chiave
MSA-...-	SA5T	T5220-IP

Einbaumöglichkeiten / Assembly options / Combinazioni di montaggio

Linker Halter Left-hand holder Adattatore sinistro	Rechter Halter Right-hand holder Adattatore destro
HVDI 30WL-7-35-MSA-SR	HVDI 30WR-7-35-MSA-SL
	
Rechtes Modul montiert Right module shown Modulo destro in figura	Linkes Modul montiert Left module shown Modulo sinistro in figura
	
Einbaulage normal Normal assembly Montaggio normale	Einbaulage normal Normal assembly Montaggio normale
	
Einbaulage Überkopf Upside down assembly Montaggio invertito	Einbaulage Überkopf Upside down assembly Montaggio invertito

Hinweis: Sonderabmessungen und Abstechhalter für andere Maschinenhersteller auf Anfrage erhältlich. Ein Anfrageblatt hierzu finden Sie auf Seite 578 oder im Internet unter: www.arno.de/service/downloads

Remark: Custom made part-off holders for other machine manufacturers are available on request. Please complete enquiry sheet on page 578 or download this from www.arno.de/service/downloads

Nota: Adattatori speciali di differenti dimensioni e caratteristiche disponibili a richiesta. Vedere modulo richiesta a Pagina 578 o download del modulo da: www.arno.de/service/downloads

--> Anwendungshinweise finden Sie auf S. 583
 --> For application reference please see page 583
 --> Per suggerimenti tecnici vedere pagina 583

Abstechhalter - MSA

Part-off holder - MSA
 Attacchi base - MSA

Abstechhalter und Direktaufnahmen

Part-off holders and flange mounted holders
 Adattori di troncatura e attacchi base

VDI40 - mit Innenkühlung / VDI40 - with internal coolant / VDI40 - con refrigerazione interna

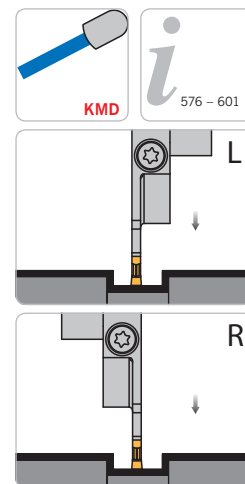
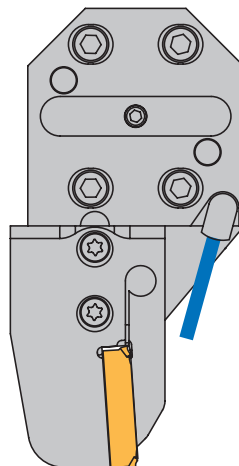
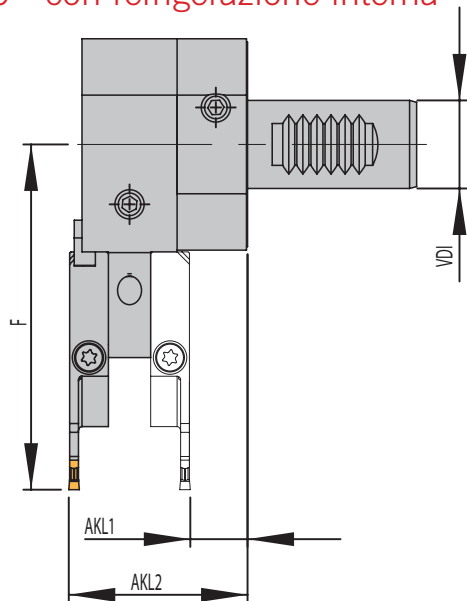

Linkes Modul montiert
 Halter höhenstellbar
 Rechtes Modul alternativ
 Left module shown
 Height adjustable holder
 Right module alternative
 Modulo sinistro in figura
 Adattatore registrabile in altezza
 Modulo destro alternativa

Grundhalter / Basic holder / Adattore

Bezeichnung Designation Articolo	VDI	AKL1	AKL2	Modul Module Modulo	PG 43
HVDS 40-1	40	21,3	55,8	MSA-...	●

Modul / Module / Modulo

F = Maße bei Modul MSA-... / F = dimension of Modul MSA-... / F = Lunghezza con modulo MSA-...

Bezeichnung Designation Articolo	VDI40...
	F
MSA-...-32	95,0
MSA-...-44	100,0
MSA-...-52	110,5
MSA-...-65	110,5
MSA-...-80	118,0
MSA-...-105	131,0
MSA-...-125	141,0
MSA-...-140	148,5

Hinweis: Passende Module finden Sie im Kapitel SA (Seite 114 bis 128)

Remark: For modules to suit please see chapter SA (Page 114 to 128)

Nota: Per i moduli abbinabili vedere pagine da 114 a 128

Ersatzteile / Spare Parts / Ricambi





Trägerwerkzeug Holder Utensile	Schraube für Modul Screw for module Vite per modulo	Schlüssel Key Chiave	Kühlmitteldüse Coolant jet Ugello refrigerante
HVDS 40-1	AS 0070	T5220-IP	KMD 0825-3E

Ersatzteile / Spare Parts / Ricambi

Modul Module Modulo	Schraube für Modul Screw for module Vite per modulo	Schlüssel Key Chiave
MSA-...	SA5T	T5220-IP



Einbaumöglichkeiten / Assembly options / Combinazioni di montaggio

<p>Linkes Modul montiert <i>Left module shown</i> Modulo sinistro in figura</p>	<p>Rechtes Modul montiert <i>Right module shown</i> Modulo destro in figura</p>
	
<p>Einbaulage normal <i>Normal assembly</i> Montaggio normale</p>	<p>Einbaulage normal <i>Normal assembly</i> Montaggio normale</p>
	
<p>Einbaulage Überkopf <i>Upside down assembly</i> Montaggio invertito</p>	<p>Einbaulage Überkopf <i>Upside down assembly</i> Montaggio invertito</p>

Hinweis: Mit einem Halter sind alle abgebildeten Varianten montierbar.

Remark: All shown options are available with only one holder.

Nota: E' sufficiente un solo corpo base per comporre tutte le combinazioni raffigurate.

Hinweis: Sonderabmessungen und Abstechhalter für andere Maschinenhersteller auf Anfrage erhältlich. Ein Anfrageblatt hierzu finden Sie auf Seite 578 oder im Internet unter: www.arno.de/service/downloads

Remark: Custom made part-off holders for other machine manufacturers are available on request. Please complete enquiry sheet on page 578 or download this from www.arno.de/service/downloads

Nota: Adattatori speciali di differenti dimensioni e caratteristiche disponibili a richiesta.

Vedere modulo richiesta a Pagina 578 o download del modulo da: www.arno.de/service/downloads

--> **Anwendungshinweise finden Sie auf S. 584/585**

--> *For application reference please see page 584/585*

--> *Per suggerimenti tecnici vedere pagina 584/585*

Abstechhalter - MSA

Part-off holder - MSA
 Attacchi base - MSA

Abstechhalter und Direktaufnahmen

Part-off holders and flange mounted holders
 Adattatori di troncatura e attacchi base

VDI40 - mit Innenkühlung / VDI40 - with internal coolant / VDI40 - con refrigerazione interna

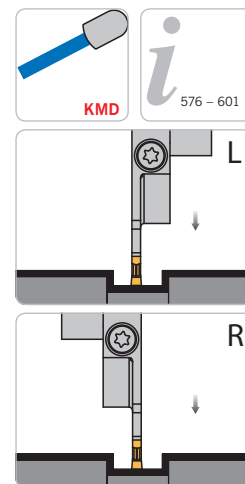
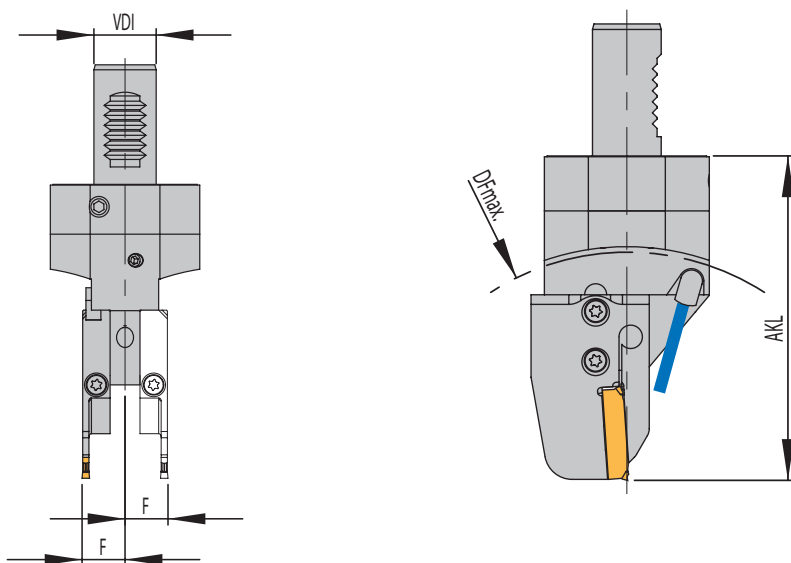

Linkes Modul montiert
 Halter höhenstellbar
 Rechtes Modul alternativ
 Left module shown
 Height adjustable holder
 Right module alternative
 Modulo sinistro in figura
 Adattatore registrabile in altezza
 Modulo destro alternativa

Grundhalter / Basic holder / Adattore

Bezeichnung Designation Articolo	VDI	F	Modul Module Modulo	PG 43
HVDS 40-7	40	17,3	MSA-...	●

Modul / Module / Modulo

DF_{max} = Maximaler Futterdurchmesser und AKL = Auskräglänge bei Modul MSA-... / DF_{max} = maximum chuck diameter and AKL = Overhang length with modules MSA-... / DF_{max} = Diametro max mandrino e AKL = Lunghezza totale con modulo MSA-...

Bezeichnung Designation Articolo	VDI40...	
	AKL	DF_{max}
MSA-...-32	130,0	170
MSA-...-44	135,0	180
MSA-...-52	145,5	200
MSA-...-65	145,5	200
MSA-...-80	163,0	215
MSA-...-105	166,0	240
MSA-...-125	176,0	260
MSA-...-140	183,5	275

Hinweis: Passende Module finden Sie im Kapitel SA (Seite 114 bis 128)

Remark: For modules to suit please see chapter SA (Page 114 to 128)

Nota: Per I moduli abbinabili vedere pagine da 114 a 128





Ersatzteile / Spare Parts / Ricambi

Trägerwerkzeug Holder Utensile	Schraube für Modul Screw for module Vite per modulo	Schlüssel Key Chiave	Kühlmitteldüse Coolant jet Ugello refrigerante
HVDS 40-7	AS 0070	T5220-IP	KMD 0825-3E

Ersatzteile / Spare Parts / Ricambi

Modul Module Modulo	Schraube für Modul Screw for module Vite per modulo	Schlüssel Key Chiave
MSA-...	SA5T	T5220-IP

Einbaumöglichkeiten / Assembly options / Combinazioni di montaggio

Linkes Modul montiert <i>Left module shown</i> Modulo sinistro in figura	Rechtes Modul montiert <i>Right module shown</i> Modulo destro in figura
	
Einbaulage normal <i>Normal assembly</i> Montaggio normale	Einbaulage normal <i>Normal assembly</i> Montaggio normale
	
Einbaulage Überkopf <i>Upside down assembly</i> Montaggio invertito	Einbaulage Überkopf <i>Upside down assembly</i> Montaggio invertito

Hinweis: Mit einem Halter sind alle abgebildeten Varianten montierbar.

Remark: All shown options are available with only one holder.

Nota: E' sufficiente un solo corpo base per comporre tutte le combinazioni raffigurate.

Hinweis: Sonderabmessungen und Abstechhalter für andere Maschinenhersteller auf Anfrage erhältlich. Ein Anfrageblatt hierzu finden Sie auf Seite 578 oder im Internet unter: www.arno.de/service/downloads

Remark: Custom made part-off holders for other machine manufacturers are available on request.

Please complete enquiry sheet on page 578 or download this from www.arno.de/service/downloads

Nota: Adattatori speciali di differenti dimensioni e caratteristiche disponibili a richiesta.

Vedere modulo richiesta a Pagina 578 o download del modulo da: www.arno.de/service/downloads

--> **Anwendungshinweise finden Sie auf S. 584/585**

--> *For application reference please see page 584/585*

--> *Per suggerimenti tecnici vedere pagina 584/585*

VDI40 - mit Innenkühlung und ACS / VDI40 - with internal coolant and ACS / VDI40 - con refrigerazione interna e ACS

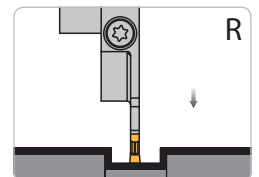
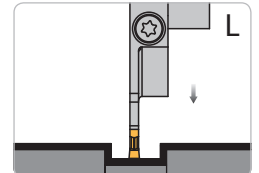
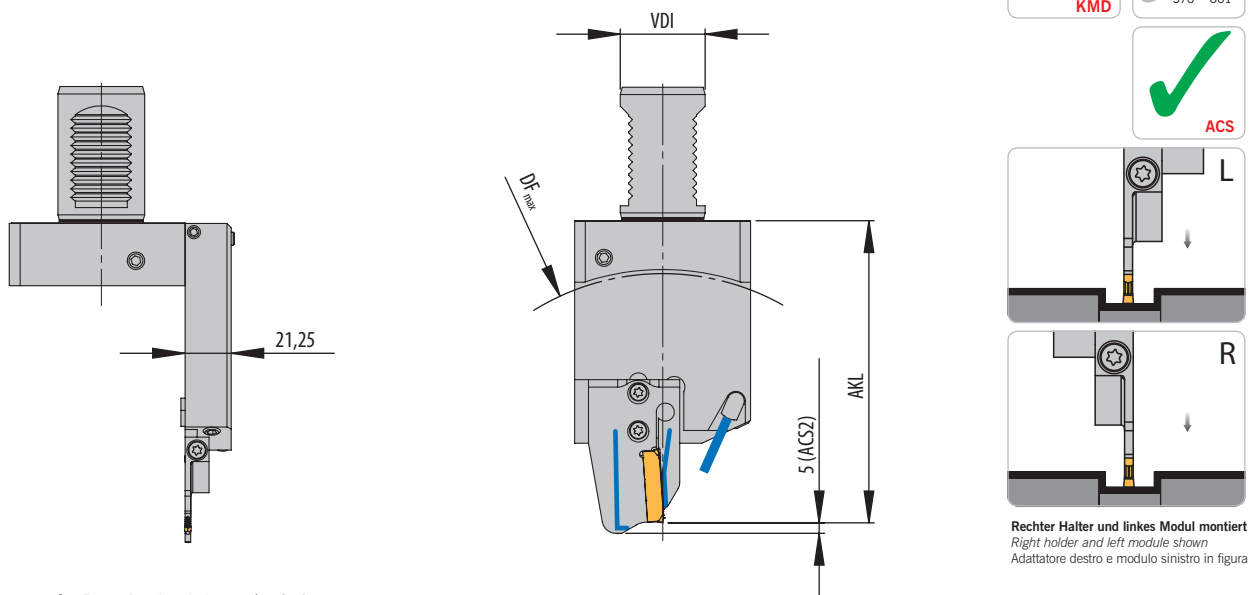

Rechter Halter und linkes Modul montiert
Right holder and left module shown
Adattatore destro e modulo sinistro in figura

Grundhalter / Basic holder / Adattore

Bezeichnung Designation Articolo	VDI	F1	F2	Modul Module Modulo	PG 43
HVDI 40L-7-38-MSA-SR	40	38,5	-	MSA-SR...-ACS.	●
HVDI 40L-7-60-MSA-SL	40	-	60,3	MSA-SL...-ACS.	●
HVDI 40R-7-38-MSA-SL	40	38,5	-	MSA-SL...-ACS.	●
HVDI 40R-7-60-MSA-SR	40	-	60,3	MSA-SR...-ACS.	●

Modul / Module / Modulo

DF_{max} = Maximaler Futterdurchmesser und AKL = Auskraglänge bei Modul MSA-... / DF_{max} = maximum chuck diameter and AKL = Overhang length with modules MSA-... / DF_{max} = Diametro max mandrino e AKL = Lunghezza totale con modulo MSA-...

Bezeichnung Designation Articolo	VDI40...	
	AKL	DF_{max}
MSA-...-32-ACS.	127,0	200
MSA-...-44-ACS.	132,0	210
MSA-...-52-ACS.	142,5	235
MSA-...-65-ACS.	142,5	235
MSA-...-69-ACS.	144,5	235
MSA-...-80-ACS.	150,0	245
MSA-...-90-ACS.	155,0	255
MSA-...-105-ACS.	163,0	270

Hinweis: Passende Module finden Sie im Kapitel SA (Seite 114 bis 128)

Remark: For modules to suit please see chapter SA (Page 114 to 128)

Nota: Per i moduli abbinabili vedere pagine da 114 a 128

Ersatzteile / Spare Parts / Ricambi

Trägerwerkzeug Holder Utensile	Schraube für Modul Screw for module Vite per modulo	Schlüssel Key Chiave	O-Ring O-ring O-Ring	Kühlmitteldüse Coolant jet Ugello refrigerante	Verschluss-Stift Locking pin Spina bloccaggio
HVDI 40.-	AS 0070	T5220-IP	OR 38,7X2,65-NBR80	KMD 0820-4BJ	ZS0820G

Ersatzteile / Spare Parts / Ricambi

Modul Module Modulo	Schraube für Modul Screw for module Vite per modulo	Schlüssel Key Chiave
MSA-...-	SA5T	T5220-IP

Einbaumöglichkeiten / Assembly options / Combinazioni di montaggio

Linker Halter Left-hand holder Adattatore sinistro		Rechter Halter Right-hand holder Adattatore destro	
HVDI 40L-7-60-MSA-SL	HVDI 40L-7-38-MSA-SR	HVDI 40R-7-28-MSA-SL	HVDI 40R-7-60-MSA-SR
Linkes Modul montiert Left module shown Modulo sinistro in figura	Rechtes Modul montiert Right module shown Modulo destro in figura	Linkes Modul montiert Left module shown Modulo sinistro in figura	Rechtes Modul montiert Right module shown Modulo destro in figura
Einbaulage normal Normal assembly Montaggio normale	Einbaulage normal Normal assembly Montaggio normale	Einbaulage normal Normal assembly Montaggio normale	Einbaulage normal Normal assembly Montaggio normale
Einbaulage Überkopf Upside down assembly Montaggio invertito	Einbaulage Überkopf Upside down assembly Montaggio invertito	Einbaulage Überkopf Upside down assembly Montaggio invertito	Einbaulage Überkopf Upside down assembly Montaggio invertito

**Hinweis: Sonderabmessungen und Abstechhalter für andere Maschinenhersteller auf Anfrage erhältlich.
 Ein Anfrageblatt hierzu finden Sie auf Seite 578 oder im Internet unter: www.arno.de/service/downloads**

Remark: Custom made part-off holders for other machine manufacturers are available on request.
 Please complete enquiry sheet on page 578 or download this from www.arno.de/service/downloads

Nota: Adattatori speciali di differenti dimensioni e caratteristiche disponibili a richiesta.
 Vedere modulo richiesta a Pagina 578 o download del modulo da: www.arno.de/service/downloads

--> Anwendungshinweise finden Sie auf S. 583
 --> For application reference please see page 583
 --> Per suggerimenti tecnici vedere pagina 583

Abstechhalter - MSA

Part-off holder - MSA
 Attacchi base - MSA

Abstechhalter und Direktaufnahmen

Part-off holders and flange mounted holders
 Adattatori di troncatura e attacchi base

VDI50 - mit Innenkühlung und ACS / VDI50 - with internal coolant and ACS / VDI50 - con refrigerazione interna e ACS

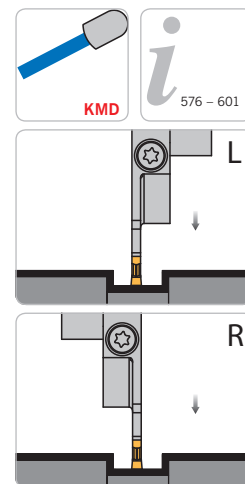
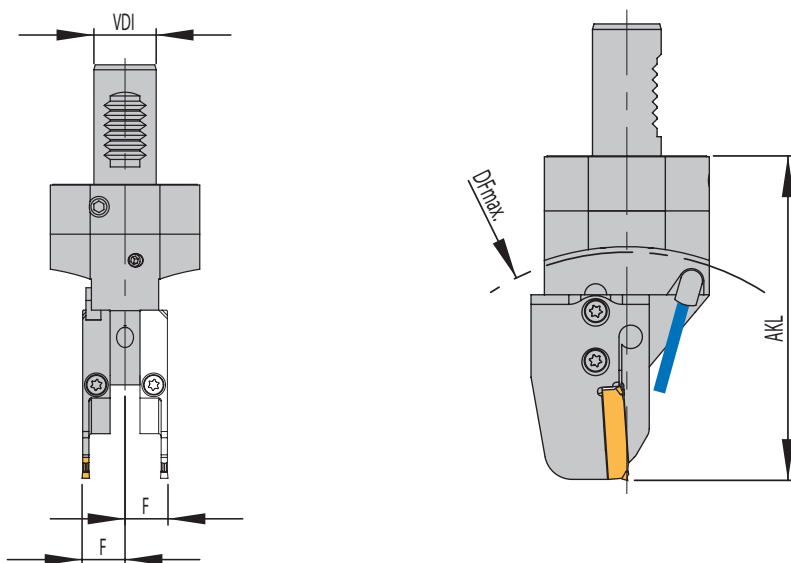

Linkes Modul montiert
 Halter höhenstellbar
 Rechtes Modul alternativ
 Left module shown
 Height adjustable holder
 Right module alternative
 Modulo sinistro in figura
 Adattatore registrabile in altezza
 Modulo destro alternativa

Grundhalter / Basic holder / Adattore

Bezeichnung Designation Articolo	VDI	F	Modul Module Modulo	PG 43
HVDS 50-7	50	17,3	MSA-...	●

Modul / Module / Modulo

DF_{max} = Maximaler Futterdurchmesser und AKL = Auskraglänge bei Modul MSA-... / DF_{max} = maximum chuck diameter and AKL = Overhang length with modules MSA-... / DF_{max} = Diametro max mandrino e AKL = Lunghezza totale con modulo MSA-...

Bezeichnung Designation Articolo	VDI50...	
	AKL	DF_{max}
MSA-...-32	130,0	170
MSA-...-44	135,0	180
MSA-...-52	145,5	200
MSA-...-65	145,5	200
MSA-...-80	153,0	215
MSA-...-105	166,0	240
MSA-...-125	176,0	260
MSA-...-140	183,5	275

Hinweis: Passende Module finden Sie im Kapitel SA (Seite 114 bis 128)

Remark: For modules to suit please see chapter SA (Page 114 to 128)

Nota: Per I moduli abbinabili vedere pagine da 114 a 128





Ersatzteile / Spare Parts / Ricambi

Trägerwerkzeug Holder Utensile	Schraube für Modul Screw for module Vite per modulo	Schlüssel Key Chiave	Kühlmitteldüse Coolant jet Ugello refrigerante
HVDS 50-7	AS 0070	T5220-IP	KMD 0825-3E

Ersatzteile / Spare Parts / Ricambi

Modul Module Modulo	Schraube für Modul Screw for module Vite per modulo	Schlüssel Key Chiave
MSA-...	SA5T	T5220-IP

Einbaumöglichkeiten / Assembly options / Combinazioni di montaggio

<p>Linkes Modul montiert <i>Left module shown</i> Modulo sinistro in figura</p>	<p>Rechtes Modul montiert <i>Right module shown</i> Modulo destro in figura</p>
	
<p>Einbaulage normal <i>Normal assembly</i> Montaggio normale</p>	<p>Einbaulage normal <i>Normal assembly</i> Montaggio normale</p>
	
<p>Einbaulage Überkopf <i>Upside down assembly</i> Montaggio invertito</p>	<p>Einbaulage Überkopf <i>Upside down assembly</i> Montaggio invertito</p>

Hinweis: Mit einem Halter sind alle abgebildeten Varianten montierbar.

Remark: All shown options are available with only one holder.

Nota: E' sufficiente un solo corpo base per comporre tutte le combinazioni raffigurate.

Hinweis: Sonderabmessungen und Abstechhalter für andere Maschinenhersteller auf Anfrage erhältlich. Ein Anfrageblatt hierzu finden Sie auf Seite 578 oder im Internet unter: www.arno.de/service/downloads

Remark: Custom made part-off holders for other machine manufacturers are available on request.

Please complete enquiry sheet on page 578 or download this from www.arno.de/service/downloads

Nota: Adattatori speciali di differenti dimensioni e caratteristiche disponibili a richiesta.

Vedere modulo richiesta a Pagina 578 o download del modulo da: www.arno.de/service/downloads

--> **Anwendungshinweise finden Sie auf S. 584/585**

--> *For application reference please see page 584/585*

--> *Per suggerimenti tecnici vedere pagina 584/585*

HSK-T63 - mit Innenkühlung und ACS / HSK-T63 - with internal coolant and ACS / HSK-T63 - con refrigerazione interna e ACS

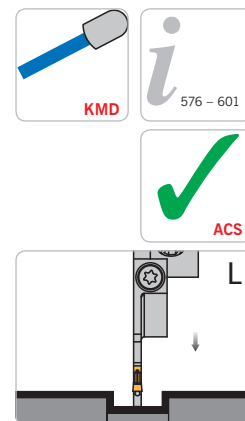
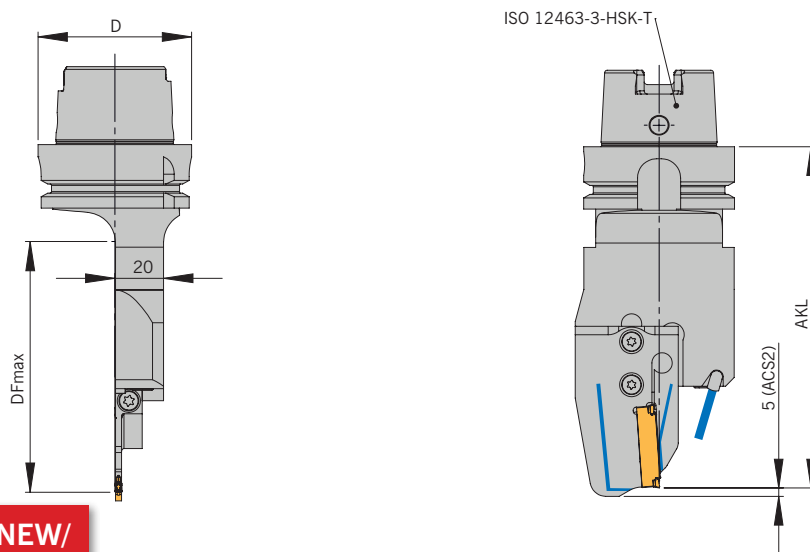

Rechter Halter und linkes Modul montiert
Right holder and left module shown
Adattatore destro e modulo sinistro in figura



Grundhalter / Basic holder / Adattore

Bezeichnung Designation Articolo	Nenngröße Nominal size Dimensione	D	Modul Module Modulo	PG 43
HSK-T63-R-7-0-MSA-SL-ACS	T63	63	MSA-SL...-ACS.	●

Hinweis: Beim Abstechen von >D90mm empfehlen wir eine max. Stechplattenbreite von 3mm.

Remark: when parting-off > Ø90mm, we recommend a max insert width of 3mm.

Nota: Da un diametro >90 mm di troncatura consigliamo noi di utilizzare massimale un spessore del tagliente di 3mm.

Modul / Module / Modulo

DF_{max} = Maximaler Futterdurchmesser und AKL = Auskräglänge bei Modul MSA-... / DF_{max} = maximum chuck diameter and AKL = Overhang length with modules MSA-... / DF_{max} = Diametro max mandrino e AKL = Lunghezza totale con modulo MSA-...

Bezeichnung Designation Articolo	...T63...	
	AKL	DF_{max}
MSA-...-32-ACS.	127,0	170
MSA-...-44-ACS.	132,0	180
MSA-...-52-ACS.	142,5	205
MSA-...-65-ACS.	142,5	205
MSA-...-69-ACS.	144,5	205
MSA-...-80-ACS.	150,0	220

Hinweis: Passende Module finden Sie im Kapitel SA (Seite 114 bis 128)

Remark: For modules to suit please see chapter SA (Page 114 to 128)

Nota: Per i moduli abbinabili vedere pagine da 114 a 128

Ersatzteile / Spare Parts / Ricambi

Trägerwerkzeug Holder Utensile	Schraube für Modul Screw for module Vite per modulo	Schlüssel Key Chiave	Kühlmitteldüse Coolant jet Ugello refrigerante	Verschluss-Stift Locking pin Spina bloccaggio
HSK-T63	AS 0070	T5220-IP	KMD 0516	ZS0512G

Ersatzteile / Spare Parts / Ricambi

Modul Module Modulo	Schraube für Modul Screw for module Vite per modulo	Schlüssel Key Chiave
MSA-...-	SA5T	T5220-IP

Einbaumöglichkeiten / Assembly options / Combinazioni di montaggio

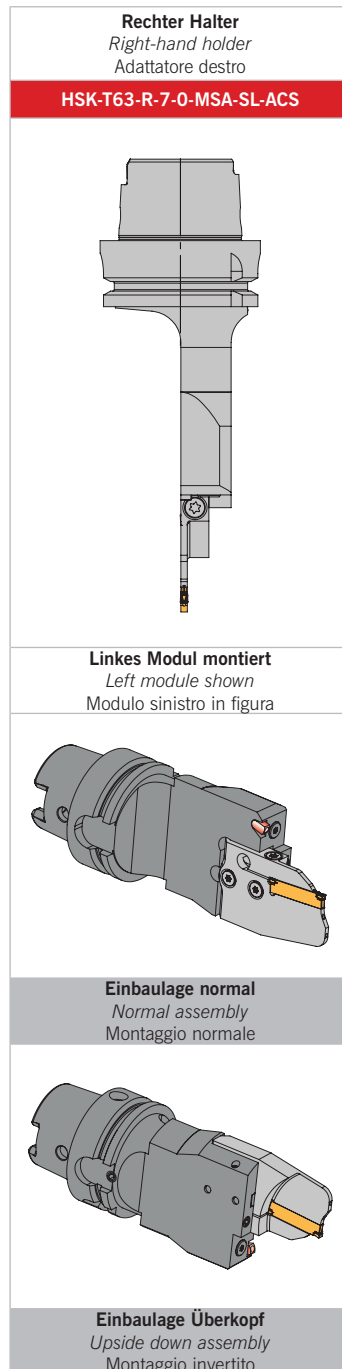

**Hinweis: Sonderabmessungen und Abstechhalter für andere Maschinenhersteller auf Anfrage erhältlich.
Ein Anfrageblatt hierzu finden Sie auf Seite 578 oder im Internet unter: www.arno.de/service/downloads**

*Remark: Custom made part-off holders for other machine manufacturers are available on request.
Please complete enquiry sheet on page 578 or download this from www.arno.de/service/downloads*

*Nota: Adattatori speciali di differenti dimensioni e caratteristiche disponibili a richiesta.
Vedere modulo richiesta a Pagina 578 o download del modulo da: www.arno.de/service/downloads*

ST-HSK-T63 (ST-Stama) - mit Innenkühlung und ACS

ST-HSK-T63 (ST-Stama) - with internal coolant and ACS

ST-HSK-T63 (ST-Stama) - con refrigerazione interna e ACS

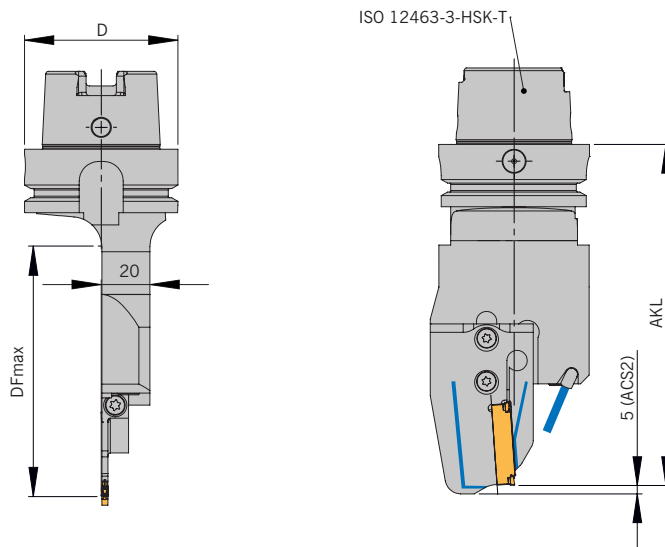
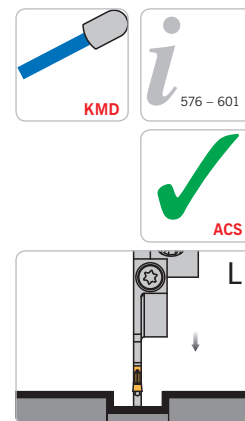

Rechter Halter und linkes Modul montiert
Right holder and left module shown
Adattatore destro e modulo sinistro in figura



Grundhalter / Basic holder / Adattore

Bezeichnung Designation Articolo	Nenngröße Nominal size Dimensione	D	Modul Module Modulo	PG 43
HST-SK-T63-R-7-0-MSA-SL-ACS	T63	63	MSA-SL-...-ACS.	●

Hinweis: Beim Abstechen von >D90mm empfehlen wir eine max. Stechplattenbreite von 3mm.
Remark: when parting-off > Ø90mm, we recommend a max insert width of 3mm.
Nota: Da un diametro >90 mm di troncatura consigliamo noi di utilizzare massimale un spessore del tagliente di 3mm.

Modul / Module / Modulo

DF_{max} = Maximaler Futterdurchmesser und AKL = Auskraglänge bei Modul MSA-... / DF_{max} = maximum chuck diameter and AKL = Overhang length with modules MSA-... / DF_{max} = Diametro max mandrino e AKL = Lunghezza totale con modulo MSA-...

Bezeichnung Designation Articolo	HST-SK-T63	
	AKL	DF _{max}
MSA-...-32-ACS.	127,0	170
MSA-...-44-ACS.	132,0	180
MSA-...-52-ACS.	142,5	205
MSA-...-65-ACS.	142,5	205
MSA-...-69-ACS.	144,5	205
MSA-...-80-ACS.	150,0	220

Hinweis: Passende Module finden Sie im Kapitel SA (Seite 114 bis 128)
Remark: For modules to suit please see chapter SA (Page 114 to 128)
Nota: Per i moduli abbinabili vedere pagine da 114 a 128

Ersatzteile / Spare Parts / Ricambi

Trägerwerkzeug Holder Utensile	Schraube für Modul Screw for module Vite per modulo	Schlüssel Key Chiave	Kühlmitteldüse Coolant jet Ugello refrigerante	Verschluss-Stift Locking pin Spina bloccaggio
ST-HSK-T63	AS 0070	T5220-IP	KMD 0516	ZS0512G

Ersatzteile / Spare Parts / Ricambi

Modul Module Modulo	Schraube für Modul Screw for module Vite per modulo	Schlüssel Key Chiave
MSA-...-	SA5T	T5220-IP

Einbaumöglichkeiten / Assembly options / Combinazioni di montaggio

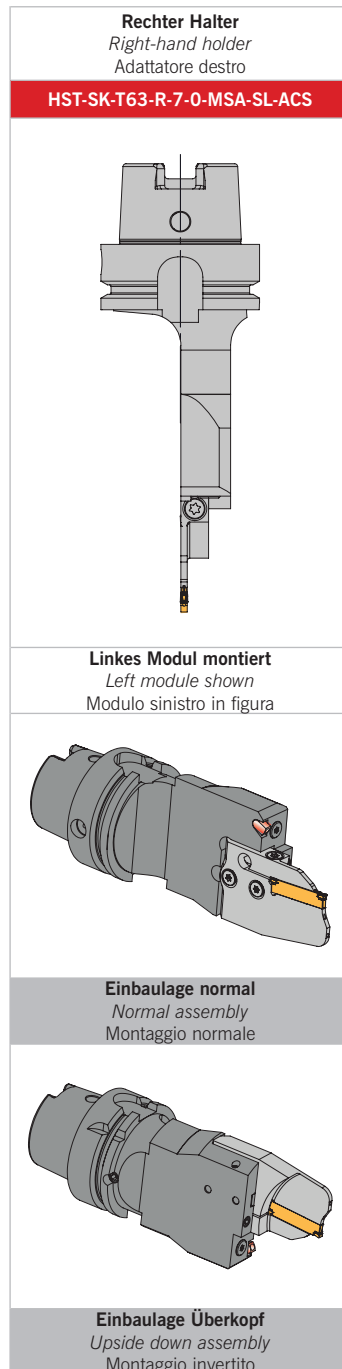

**Hinweis: Sonderabmessungen und Abstechhalter für andere Maschinenhersteller auf Anfrage erhältlich.
Ein Anfrageblatt hierzu finden Sie auf Seite 578 oder im Internet unter: www.arno.de/service/downloads**

*Remark: Custom made part-off holders for other machine manufacturers are available on request.
Please complete enquiry sheet on page 578 or download this from www.arno.de/service/downloads*

*Nota: Adattatori speciali di differenti dimensioni e caratteristiche disponibili a richiesta.
Vedere modulo richiesta a Pagina 578 o download del modulo da: www.arno.de/service/downloads*

PSC40/PSC50/PSC63 - mit Innenkühlung und ACS

PSC40/PSC50/PSC63 - with internal coolant and ACS
 PSC40/PSC50/PSC63 - con refrigerazione interna e ACS

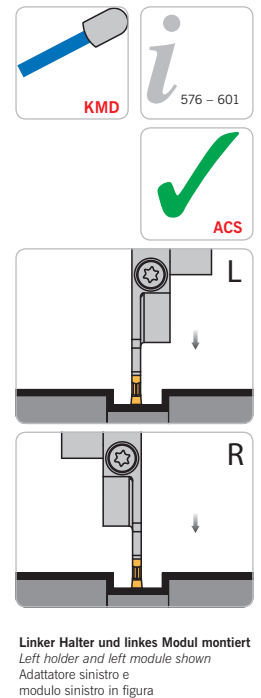
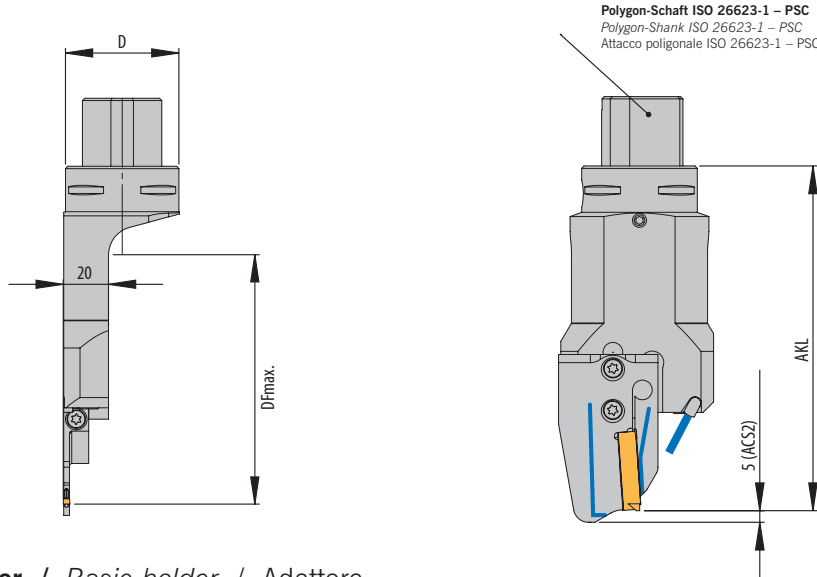

Grundhalter / Basic holder / Adattore

Bezeichnung Designation Articolo	Nenngröße Nominal size Dimensione	D	F2	Modul Module Modulo	PG 43
PSC40-L-7-21-MSA-SL-ACS	PSC40	40	21	MSA-SL-...-ACS.	●
PSC40-R-7-21-MSA-SR-ACS	PSC40	40	21	MSA-SR-...-ACS.	●
PSC50-L-7-26-MSA-SL-ACS	PSC50	50	26	MSA-SL-...-ACS.	●
PSC50-R-7-26-MSA-SR-ACS	PSC50	50	26	MSA-SR-...-ACS.	●
PSC63-L-7-32-MSA-SL-ACS	PSC63	63	32	MSA-SL-...-ACS.	●
PSC63-R-7-32-MSA-SR-ACS	PSC63	63	32	MSA-SR-...-ACS.	●

* Wenn Werkstück größer Ø 200 ist, dann ist auch ein größeres DFmax möglich. Bei Bedarf bitte anfragen.
 * When component is larger than 200 mm diameter, then larger DFmax is possible. Please ask for more information.
 * Se il pezzo è superiore a Ø 200, è possibile avere una quota DFmax maggiore.

Modul / Module / Modulo

DF_{max} = Maximaler Futterdurchmesser und AKL = Auskräglänge bei Modul MSA-... / DF_{max} = maximum chuck diameter and AKL = Overhang length with modules MSA-... / DF_{max} = Diametro max mandrino e AKL = Lunghezza totale con modulo MSA-...

Bezeichnung Designation Articolo	PSC40...		PSC50...		PSC60...	
	AKL	DF _{max}	AKL	DF _{max}	AKL	DF _{max}
MSA-...-32-ACS.	128,5	175	133,5	185	142,0	190
MSA-...-44-ACS.	133,5	185	138,5	195	147,0	200
MSA-...-52-ACS.	144,0	210	149,0	215	157,5	220
MSA-...-65-ACS.	144,0	210	149,0	215	157,5	220
MSA-...-69-ACS.	146,0	215	151,0	220	159,5	225
MSA-...-80-ACS.	151,5	225	156,5	230	165,0	235
MSA-...-90-ACS.	156,5	235	164,5	250	178,0	260
MSA-...-105-ACS.	164,5	250	169,5	255	178,0	260

Hinweis: Passende Module finden Sie im Kapitel SA (Seite 114 bis 128)
 Remark: For modules to suit please see chapter SA (Page 114 to 128)
 Nota: Per I moduli abbinabili vedere pagine da 114 a 128

Ersatzteile / Spare Parts / Ricambi

Trägerwerkzeug Holder Utensile	Schraube für Modul Screw for module Vite per modulo	Schlüssel Key Chiave	Kühlmitteldüse Coolant jet Ugello refrigerante	Verschluss-Stift Locking pin Spina bloccaggio
PSC.L-/PSC.R.-	AS 0070	T5220-IP	KMD 0516	ZS0512G

Ersatzteile / Spare Parts / Ricambi

Modul Module Modulo	Schraube für Modul Screw for module Vite per modulo	Schlüssel Key Chiave
MSA-...-	SA5T	T5220-IP





Abstechhalter - Polygonschaft

Flange mounted holder - Polygon-Shank
 Attacchi base - Attacco poligonale

Abstechhalter und Direktaufnahmen

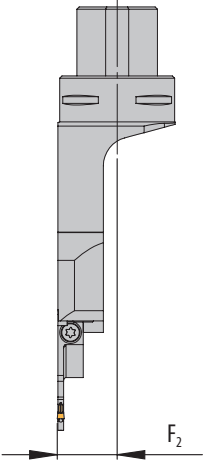
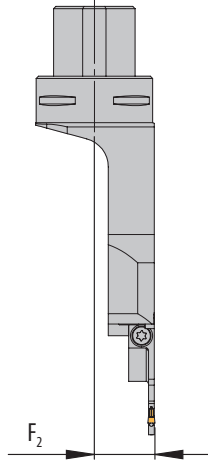
Part-off holders and flange mounted holders
 Adattatori di troncatura e attacchi base

Einbaumöglichkeiten / Assembly options / Combinazioni di montaggio

Linker Halter <i>Left-hand holder</i> Adattatore sinistro	Rechter Halter <i>Right-hand holder</i> Adattatore destro
PSC40-L-7-21-MSA-SL-ACS	PSC40-R-7-21-MSA-SR-ACS
PSC50-L-7-26-MSA-SL-ACS	PSC50-R-7-26-MSA-SR-ACS
PSC63-L-7-32-MSA-SL-ACS	PSC63-R-7-32-MSA-SR-ACS
	
Linkes Modul montiert <i>Left module shown</i> Modulo sinistro in figura	Rechtes Modul montiert <i>Right module shown</i> Modulo destro in figura
	
Einbaulage normal <i>Normal assembly</i> Montaggio normale	Einbaulage normal <i>Normal assembly</i> Montaggio normale
	
Einbaulage Überkopf <i>Upside down assembly</i> Montaggio invertito	Einbaulage Überkopf <i>Upside down assembly</i> Montaggio invertito

Hinweis: Sonderabmessungen und Abstechhalter für andere Maschinenhersteller auf Anfrage erhältlich. Ein Anfrageblatt hierzu finden Sie auf Seite 578 oder im Internet unter: www.arno.de/service/downloads

Remark: Custom made part-off holders for other machine manufacturers are available on request. Please complete enquiry sheet on page 578 or download this from www.arno.de/service/downloads

Nota: Adattatori speciali di differenti dimensioni e caratteristiche disponibili a richiesta. Vedere modulo richiesta a Pagina 578 o download del modulo da: www.arno.de/service/downloads

Abstechhalter - Polygonschaft

Flange mounted holder - Polygon-Shank
 Attacchi base - Attacco poligonale

Abstechhalter und Direktaufnahmen

Part-off holders and flange mounted holders
 Adattatori di troncatura e attacchi base

PSC40 - mit Innenkühlung und ACS / PSC40 - with internal coolant and ACS / PSC40 - con refrigerazione interna e ACS

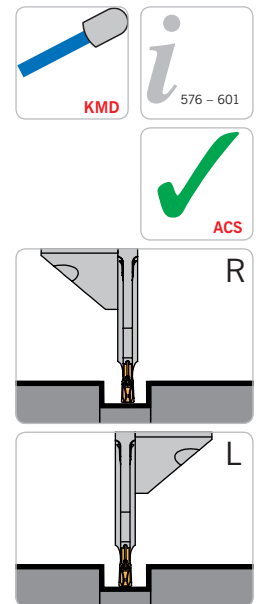
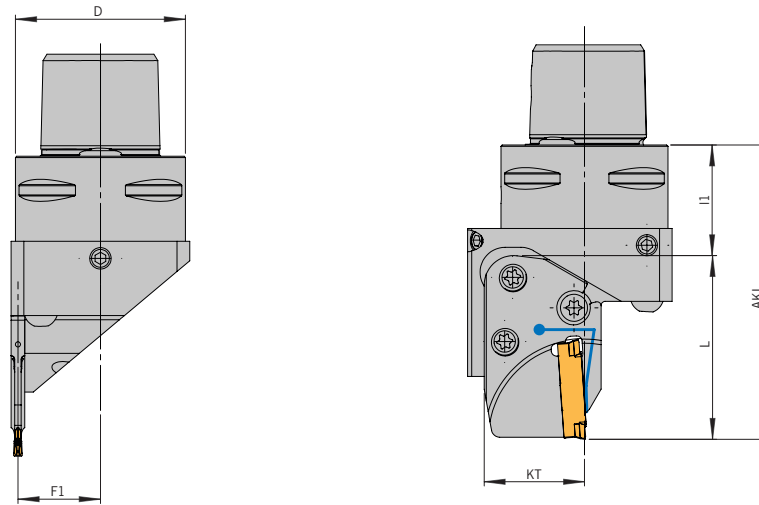

Linker Halter und linkes Modul montiert
 Left holder and left module shown
 Adattatore sinistro e modulo sinistro in figura



Grundhalter / Basic holder / Adattore

Bezeichnung Designation Articolo	Nenngröße Nominal size Dimensione	D	L1	F1	Modul Module Modulo	PG 43
PSC40-L-7-21-MSA-IL-ACS	PSC40	40	26,5	19,4	MSA-IL/ILL...-ACS.	●
PSC40-R-7-21-MSA-IR-ACS	PSC40	40	26,5	19,4	MSA-IR/IRR...-ACS.	●

Modul / Module / Modulo

DF_{max} = Maximaler Futterdurchmesser und AKL = Auskräglänge bei Modul MSA-... / DF_{max} = maximum chuck diameter and AKL = Overhang length with modules MSA-... / DF_{max} = Diametro max mandrino e AKL = Lunghezza totale con modulo MSA-...

Bezeichnung Designation Articolo	PSC40...	
	AKL 1)	DF_{max}
MSA-I.-L37...-ACS.	63,5	2)
MSA-I.-L41...-ACS.	67,5	2)
MSA-I.-L43,5...-ACS.	69,0	2)
MSA-I.-L44...-ACS.	70,5	2)
MSA-I.-L45,5...-ACS.	72,0	2)
MSA-I.-L48,5...-ACS.	75,0	2)
MSA-I.-L55...-ACS.	81,5	2)

1) Berechnung AKL nicht aufgeführter Module: $AKL = l_1 + L$ (Länge des Moduls)

1) Calculation for AKL if the module is not mentioned: $AKL = l_1 + L$ (length of the module)

1) Calcolo della misura AKL degli moduli non citati: $AKL = l_1 + L$ (lunghezza del modulo)

2) Berechnung F-Maß bei MSA-IL/IR: $F = F_1 + EB/2$ (Halbe EB des Moduls), Berechnung F-Maß bei MSA-ILL/IRR: $F = F_1 + 1,6$ (Halbe Breite des Moduls)

2) Calculation F-dimension for: MSA-IL/IR: $F = F_1 + 1/2 EB$ (1/2 EB = 1/2 grooving width), Calculation F-dimension for: MSA-ILL/IRR: $F = F_1 + 1,6$ (1,6 = 1/2 b2)

2) Calcolo della misura F da MSA-IL/IR: $F = F_1 + EB/2$ (metà del spessore del modulo), Calcolo della misura F da MSA-ILL/IRR: $F = F_1 + 1,6$ (metà del spessore del modulo)

Hinweis: Passende Module finden Sie im Kapitel SA (Seite 114 bis 128)

Remark: For modules to suit please see chapter SA (Page 114 to 128)

Nota: Per i moduli abbinabili vedere pagine da 114 a 128

Ersatzteile / Spare Parts / Ricambi

Trägerwerkzeug Holder Utensile	Schraube für Modul Screw for module Vite per modulo	Schlüssel Key Chiave
PSC..	2 x AS 0049 / 1 x AS 0050*	T5220-IP

* Alternativ AS 0050D (doppelseitig IP20)

* Alternatively AS 0050D (double sided IP20)

* Alternativo AS 0050D (bilateralmente IP20)

Einbaumöglichkeiten / Assembly options / Combinazioni di montaggio

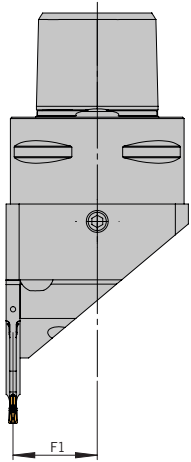
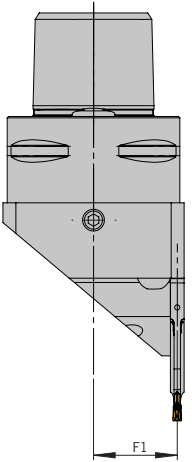
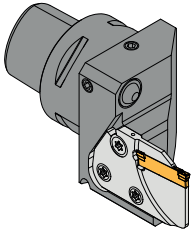
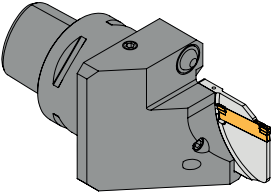
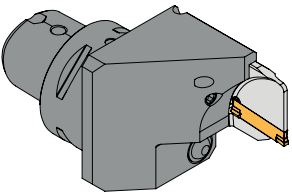
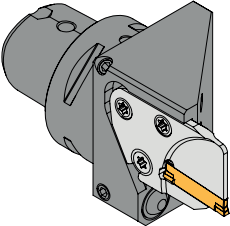
Linker Halter Left-hand holder Adattatore sinistro	Rechter Halter Right-hand holder Adattatore destro
PSC40-L-7-21-MSA-IL-ACS	PSC40-R-7-21-MSA-IR-ACS
	
Linkes Modul montiert Left module shown Modulo sinistro in figura	Rechtes Modul montiert Right module shown Modulo destro in figura
	
Einbaulage normal Normal assembly Montaggio normale	Einbaulage normal Normal assembly Montaggio normale
	
Einbaulage Überkopf Upside down assembly Montaggio invertito	Einbaulage Überkopf Upside down assembly Montaggio invertito

Hinweis: Sonderabmessungen und Abstechhalter für andere Maschinenhersteller auf Anfrage erhältlich. Ein Anfrageblatt hierzu finden Sie auf Seite 578 oder im Internet unter: www.arno.de/service/downloads

Remark: Custom made part-off holders for other machine manufacturers are available on request. Please complete enquiry sheet on page 578 or download this from www.arno.de/service/downloads

Nota: Adattatori speciali di differenti dimensioni e caratteristiche disponibili a richiesta. Vedere modulo richiesta a Pagina 578 o download del modulo da: www.arno.de/service/downloads

--> Anwendungshinweise finden Sie auf S. 600/601

--> For application reference please see page 600/601

--> Per suggerimenti tecnici vedere pagina 600/601

HBSA - mit Innenkühlung und ACS / HBSA - with internal coolant and ACS / HBSA - con refrigerazione interna e ACS

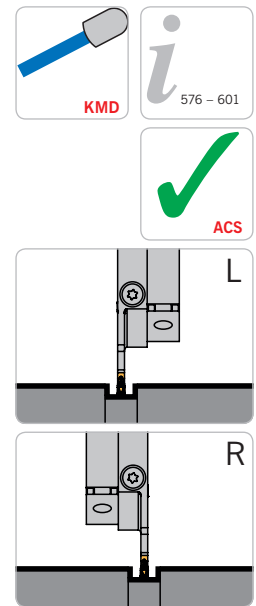
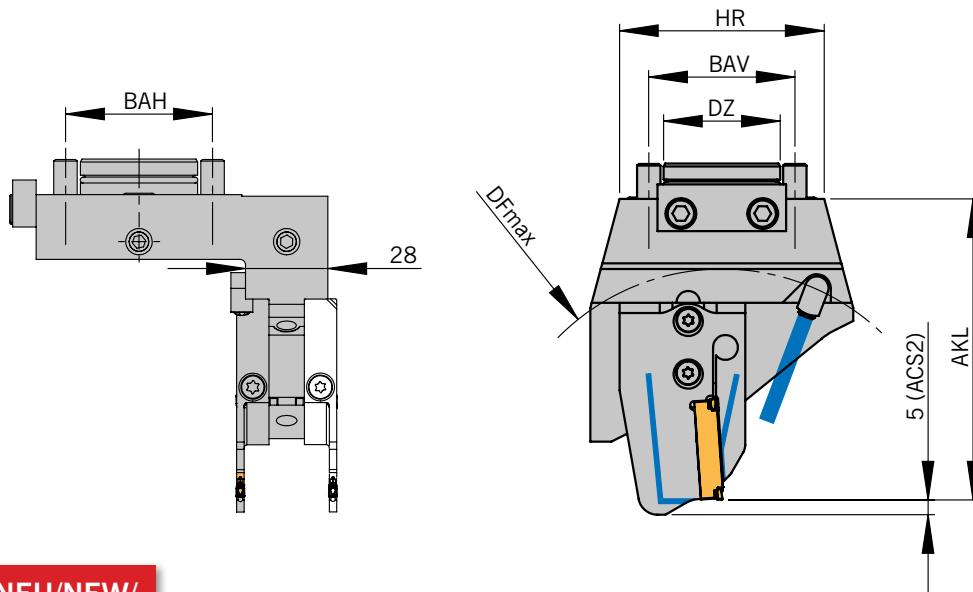

Rechter Halter und linkes Modul montiert
 Halter höhenstellbar
 Rechtes Modul alternativ
 Right holder and left module shown
 Height adjustable holder
 Right module alternative
 Adattatore destro e modulo sinistro in figura
 Adattatore registrabile in altezza
 Modulo destro alternativa



Grundhalter / Basic holder / Adattore

Bezeichnung Designation Articolo	BAH	BAV	HR	DZ	F1	F2	Modul Module Modulo	PG 43
HBSA-50-50-R-ACS	50	50	70	40	33	67,5	MSA-...-ACS.	●

Modul / Module / Modulo

DF_{max} = Maximaler Futterdurchmesser und AKL = Auskräglänge bei Modul MSA-... / DF_{max} = maximum chuck diameter and AKL = Overhang length with modules MSA-... / DF_{max} = Diametro max mandrino e AKL = Lunghezza totale con modulo MSA-...

Bezeichnung Designation Articolo	HBSA...	
	AKL	DF_{max}
MSA-...-32-ACS.	87,5	125
MSA-...-44-ACS.	92,5	135
MSA-...-52-ACS.	103,0	155
MSA-...-65-ACS.	103,0	155
MSA-...-69-ACS.	105,0	160
MSA-...-80-ACS.	110,5	170
MSA-...-90-ACS.	115,5	180
MSA-...-105-ACS.	123,5	195

Hinweis: Passende Module finden Sie im Kapitel SA (Seite 114 bis 128)

Remark: For modules to suit please see chapter SA (Page 114 to 128)

Nota: Per i moduli abbinabili vedere pagine da 114 a 128







Ersatzteile / Spare Parts / Ricambi

Trägerwerkzeug Holder Utensile	Schraube für Modul Screw for module Vite per modulo	Schlüssel Key Chiave	O-Ring O-ring O-Ring	O-Ring 2 O-ring 2 O-Ring 2	O-Ring 3 O-Ring 3 O-Ring 3	Kühlmitteldüse Coolant jet Ugello refrigerante	Verschluss-Stift Locking pin Spina bloccaggio
HBSA-50-50-R-ACS	AS 0070	T5220-IP	OR 36X2 P	OR 30X2-N-NBR70	OR 7X2 P	KMD 0825-3E	ZS0818

Ersatzteile / Spare Parts / Ricambi

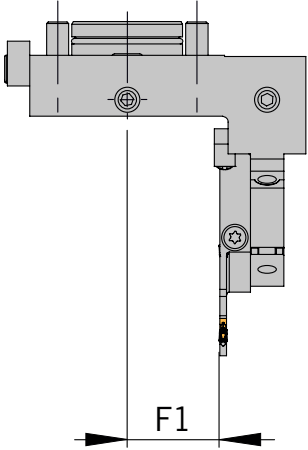
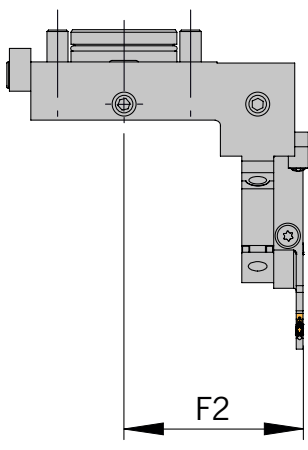
Modul Module Modulo	Schraube für Modul Screw for module Vite per modulo	Schlüssel Key Chiave
MSA-...-	SA5T	T5220-IP

Einbaumöglichkeiten / Assembly options / Combinazioni di montaggio

Rechter Halter Right-hand holder Adattatore destro HBSA-50-50-R-ACS	
 <p>F1</p>	 <p>F2</p>
Linkes Modul montiert Left module shown Modulo sinistro in figura	Rechtes Modul montiert Right module shown Modulo destro in figura
	
Einbaulage normal Normal assembly Montaggio normale	Einbaulage normal Normal assembly Montaggio normale
	
Einbaulage Überkopf Upside down assembly Montaggio invertito	Einbaulage Überkopf Upside down assembly Montaggio invertito

Hinweis: Mit einem Halter sind alle abgebildeten Varianten montierbar.

Remark: All shown options are available with only one holder.

Nota: E' sufficiente un solo corpo base per comporre tutte le combinazioni raffigurate.

Hinweis: Sonderabmessungen und Abstechhalter für andere Maschinenhersteller auf Anfrage erhältlich. Ein Anfrageblatt hierzu finden Sie auf Seite 578 oder im Internet unter: www.arno.de/service/downloads

Remark: Custom made part-off holders for other machine manufacturers are available on request. Please complete enquiry sheet on page 578 or download this from www.arno.de/service/downloads

Nota: Adattatori speciali di differenti dimensioni e caratteristiche disponibili a richiesta.

Vedere modulo richiesta a Pagina 578 o download del modulo da: www.arno.de/service/downloads

HBSA - mit Innenkühlung und ACS / HBSA - with internal coolant and ACS / HBSA - con refrigerazione interna e ACS

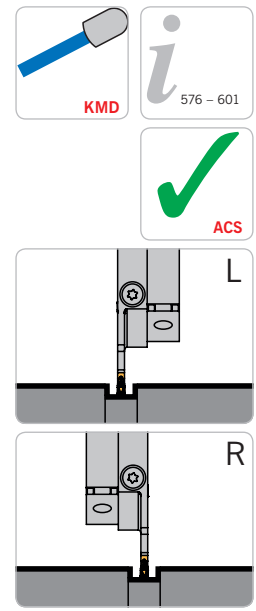
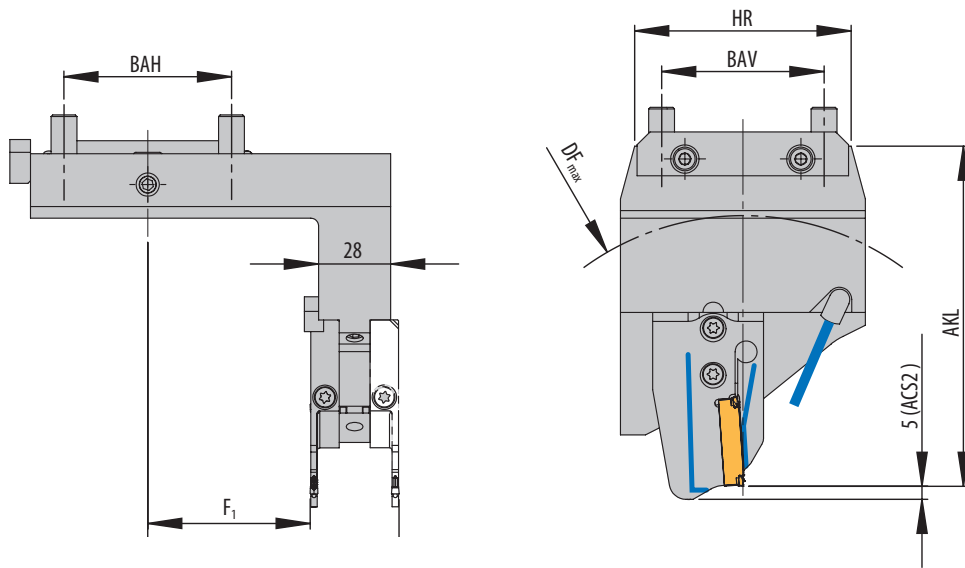

Rechter Halter und linkes Modul montiert
 Halter höhenstellbar
 Rechtes Modul alternativ
 Right holder and left module shown
 Height adjustable holder
 Right module alternative
 Adattatore destro e modulo sinistro in figura
 Adattatore registrabile in altezza
 Modulo destro alternativa

Grundhalter / Basic holder / Adattore

Bezeichnung Designation Articolo	BAH	BAV	HR	F1	F2	Modul Module Modulo	PG 43
HBSA-65-63-R-ACS	65	63	84	63	97,5	MSA-...-ACS.	●
HBSA-65-63-120-L-ACS	65	63	84	63	97,5	MSA-...-ACS.	●

Modul / Module / Modulo

DF_{max} = Maximaler Futterdurchmesser und AKL = Auskraglänge bei Modul MSA-... / DF_{max} = maximum chuck diameter and AKL = Overhang length with modules MSA-... / DF_{max} = Diametro max mandrino e AKL = Lunghezza totale con modulo MSA-...

Bezeichnung Designation Articolo	HBSA...		HBSA-120...	
	AKL	DF_{max}	AKL	DF_{max}
MSA-...-32-ACS.	116,5	175	104,5	160
MSA-...-44-ACS.	121,5	185	109,5	170
MSA-...-52-ACS.	132,0	210	120,0	190
MSA-...-65-ACS.	132,0	210	120,0	190
MSA-...-69-ACS.	134,0	215	122,0	195
MSA-...-80-ACS.	139,5	225	127,5	205
MSA-...-90-ACS.	144,5	235	132,5	215
MSA-...-105-ACS.	152,5	250	140,5	230

Hinweis: Passende Module finden Sie im Kapitel SA (Seite 114 bis 128)
 Remark: For modules to suit please see chapter SA (Page 114 to 128)
 Nota: Per i moduli abbinabili vedere pagine da 114 a 128

Ersatzteile / Spare Parts / Ricambi

Trägerwerkzeug Holder Utensile	Schraube für Modul Screw for module Vite per modulo	Schlüssel Key Chiave	Nutenstein 1 T-slot fixture 1 T-slot slot 1	Nutenstein 2 T-slot fixture 2 T-slot slot 2	O-Ring O-ring O-Ring	Kühlmitteldüse Coolant jet Ugello refrigerante
HBSA-65-63-..	AS 0070	T5220-IP	NS 15/14X10X69	NS 20X9,7X15	OR 7X2 P	KMD 0825-3E

Ersatzteile / Spare Parts / Ricambi

Modul Module Modulo	Schraube für Modul Screw for module Vite per modulo	Schlüssel Key Chiave
MSA-...	SA5T	T5220-IP



Einbaumöglichkeiten / Assembly options / Combinazioni di montaggio

Linker Halter Left-hand holder Adattatore sinistro HBSA-65-63-120-L-ACS		Rechter Halter Right-hand holder Adattatore destro HBSA-65-63-R-ACS	
Linkes Modul montiert Left module shown Modulo sinistro in figura	Rechtes Modul montiert Right module shown Modulo destro in figura	Linkes Modul montiert Left module shown Modulo sinistro in figura	Rechtes Modul montiert Right module shown Modulo destro in figura
Einbaulage normal Normal assembly Montaggio normale	Einbaulage normal Normal assembly Montaggio normale	Einbaulage normal Normal assembly Montaggio normale	Einbaulage normal Normal assembly Montaggio normale
Einbaulage Überkopf Upside down assembly Montaggio invertito	Einbaulage Überkopf Upside down assembly Montaggio invertito	Einbaulage Überkopf Upside down assembly Montaggio invertito	Einbaulage Überkopf Upside down assembly Montaggio invertito

Hinweis: Sonderabmessungen und Abstechhalter für andere Maschinenhersteller auf Anfrage erhältlich. Ein Anfrageblatt hierzu finden Sie auf Seite 578 oder im Internet unter: www.arno.de/service/downloads

Remark: Custom made part-off holders for other machine manufacturers are available on request. Please complete enquiry sheet on page 578 or download this from www.arno.de/service/downloads

Nota: Adattatori speciali di differenti dimensioni e caratteristiche disponibili a richiesta. Vedere modulo richiesta a Pagina 578 o download del modulo da: www.arno.de/service/downloads

HCMZ - mit Innenkühlung und ACS / HCMZ - with internal coolant and ACS / HCMZ - con refrigerazione interna e ACS

Grundhalter / Basic holders / Corpo utensili

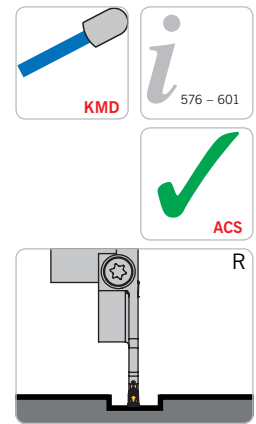
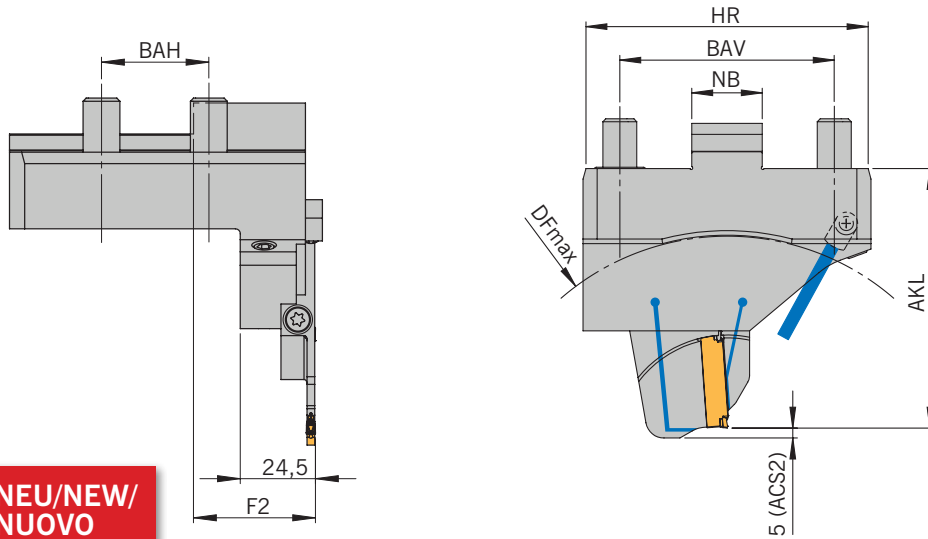

Rechter Halter und rechtes Modul montiert
Right holder and right module shown
Adattatore destro e modulo destro in figura



Grundhalter / Basic holder / Adattore

Bezeichnung Designation Articolo	BAH	BAV	HR	NB	F2	Modul Module Modulo	PG 43
HCMZ-35-76-R-MSA-SR-ACS	35	76	100	25	39,8	MSA-SR-...-ACS.	●

Modul / Module / Modulo

DF_{max} = Maximaler Futterdurchmesser und AKL = Auskräglänge bei Modul MSA-... / *DF_{max} = maximum chuck diameter and AKL = Overhang length with modules MSA-...* / **DF_{max} = Diametro max mandrino e AKL = Lunghezza totale con modulo MSA-...**

Bezeichnung Designation Articolo	HCMZ...	
	AKL	DF _{max}
MSA-...-32-ACS.	76,5	105
MSA-...-44-ACS.	81,5	115
MSA-...-52-ACS.	92,0	135
MSA-...-65-ACS.	92,0	135
MSA-...-69-ACS.	94,0	140
MSA-...-80-ACS.	99,5	150
MSA-...-90-ACS.	104,5	160
MSA-...-105-ACS.	112,5	175

Hinweis: Passende Module finden Sie im Kapitel SA (Seite 114 bis 128)

Remark: For modules to suit please see chapter SA (Page 114 to 128)

Nota: Per I moduli abbinabili vedere pagine da 114 a 128

Ersatzteile / Spare Parts / Ricambi

Trägerwerkzeug Holder Utensile	Schraube für Modul Screw for module Vite per modulo	Schlüssel Key Chiave	O-Ring O-ring O-Ring	O-Ring 2 O-ring 2 O-Ring 2	Kühlmitteldüse Coolant jet Ugello refrigerante	Verschluss-Stift Locking pin Spina bloccaggio
HCMZ-35-...-ACS	AS 0070	T5220-IP	OR 2,95X0,79 NBR70	OR 14,82X1,78- NBR70	KMD 0825-3E	ZS0820G

Ersatzteile / Spare Parts / Ricambi

Modul Module Modulo	Schraube für Modul Screw for module Vite per modulo	Schlüssel Key Chiave
MSA-...-	SA5T	T5220-IP

Einbaumöglichkeiten / Assembly options / Combinazioni di montaggio

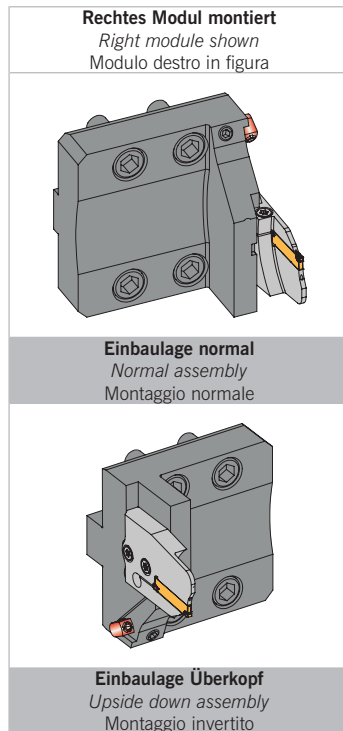

Hinweis: Mit einem Halter sind alle abgebildeten Varianten montierbar.

Remark: All shown options are available with only one holder.

Nota: E' sufficiente un solo corpo base per comporre tutte le combinazioni raffigurate.

**Hinweis: Sonderabmessungen und Abstechhalter für andere Maschinenhersteller auf Anfrage erhältlich.
Ein Anfrageblatt hierzu finden Sie auf Seite 578 oder im Internet unter: www.arno.de/service/downloads**

*Remark: Custom made part-off holders for other machine manufacturers are available on request.
Please complete enquiry sheet on page 578 or download this from www.arno.de/service/downloads*

*Nota: Adattatori speciali di differenti dimensioni e caratteristiche disponibili a richiesta.
Vedere modulo richiesta a Pagina 578 o download del modulo da: www.arno.de/service/downloads*

BMT - mit Innenkühlung und ACS / BMT - with internal coolant and ACS / BMT - con refrigerazione interna e ACS

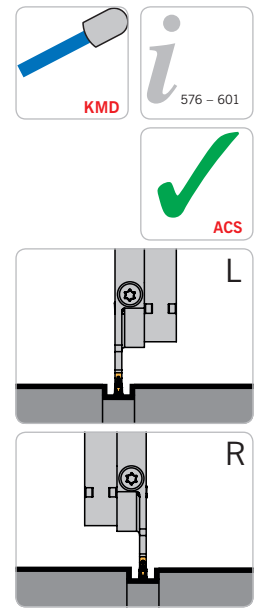
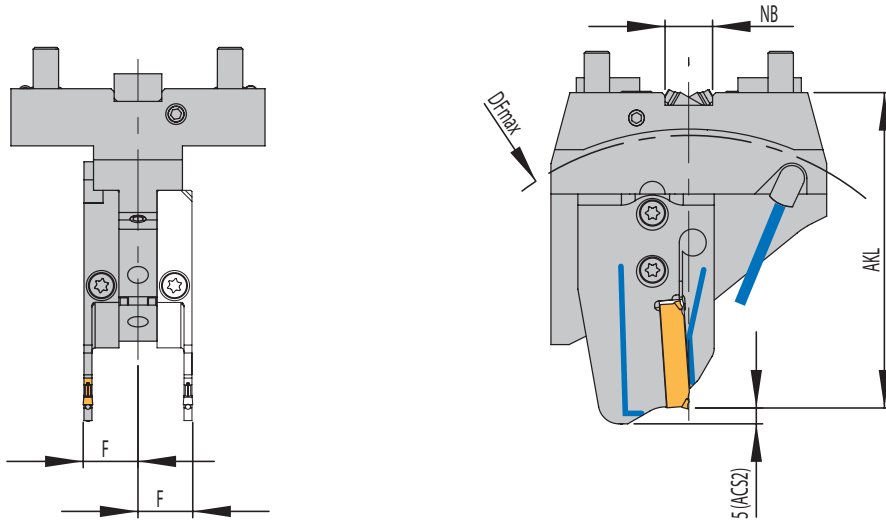

Linkes Modul montiert
 Halter höhenstellbar
 Rechtes Modul alternativ
 Left module shown
 Height adjustable holder
 Right module alternative
 Modulo sinistro in figura
 Adattatore registrabile in altezza
 Modulo destro alternativa

N NEU/NEW/NUOVO

Grundhalter / Basic holder / Adattore

Bezeichnung Designation Articolo	NB	F	Modul Module Modulo	PG 43
HDD-BMT45-SDS-ACS	15	17.3	MSA-...-ACS.	●
HDD-BMT55-SDS-150-ACS	15	17.3	MSA-...-ACS.	●
HDD-BMT55-SDS-ACS	15	17.3	MSA-...-ACS.	●
HDD-BMT65-SDS-ACS	18	17.3	MSA-...-ACS.	●

Modul / Module / Modulo

DF_{max} = Maximaler Futterdurchmesser und AKL = Auskraglänge bei Modul MSA-... / DF_{max} = maximum chuck diameter and AKL = Overhang length with modules MSA-... / DF_{max} = Diametro max mandrino e AKL = Lunghezza totale con modulo MSA-...

Bezeichnung Designation Articolo	BMT45...		BMT55...		BMT55...-150		BMT65...	
	AKL	DF_{max}	AKL	DF_{max}	AKL	DF_{max}	AKL	DF_{max}
MSA-...-32-ACS.	84,0	140	114,5	185	134,5	225	131,5	215
MSA-...-44-ACS.	89,0	150	119,5	195	139,5	235	136,5	225
MSA-...-52-ACS.	99,5	170	130,0	215	150,0	255	147,0	245
MSA-...-65-ACS.	99,5	170	130,0	215	150,0	255	147,0	245
MSA-...-69-ACS.	101,5	175	132,0	220	152,0	260	149,0	250
MSA-...-80-ACS.	107,0	185	137,5	230	157,5	270	154,5	260
MSA-...-90-ACS.	112,0	195	142,5	240	162,5	280	159,5	270
MSA-...-105-ACS.	120,0	210	150,5	255	170,5	295	167,5	285

Hinweis: Passende Module finden Sie im Kapitel SA (Seite 114 bis 128)

Remark: For modules to suit please see chapter SA (Page 114 to 128)

Nota: Per i moduli abbinabili vedere pagine da 114 a 128





Ersatzteile / Spare Parts / Ricambi

Trägerwerkzeug Holder Utensile	Schraube für Modul Screw for module Vite per modulo	Schlüssel Key Chiave	O-Ring O-ring O-Ring	Kühlmitteldüse Coolant jet Ugello refrigerante
HDD-BMT45-SDS-ACS	AS 0070	T5220-IP	OR 7X1,5 P	KMD 0825-3E
HDD-BMT55-SDS..-ACS	AS 0070	T5220-IP	OR 8X1,5 P	KMD 0825-3E
HDD-BMT65-SDS-ACS	AS 0070	T5220-IP	OR 9X1,5 P	KMD 0825-3E

Ersatzteile / Spare Parts / Ricambi

Modul Module Modulo	Schraube für Modul Screw for module Vite per modulo	Schlüssel Key Chiave
MSA-...-	SA5T	T5220-IP

Einbaumöglichkeiten / Assembly options / Combinazioni di montaggio

Linkes Modul montiert <i>Left module shown</i> Modulo sinistro in figura	Rechtes Modul montiert <i>Right module shown</i> Modulo destro in figura
	
Einbaulage normal <i>Normal assembly</i> Montaggio normale	Einbaulage normal <i>Normal assembly</i> Montaggio normale
	
Einbaulage Überkopf <i>Upside down assembly</i> Montaggio invertito	Einbaulage Überkopf <i>Upside down assembly</i> Montaggio invertito

Hinweis: Mit einem Halter sind alle abgebildeten Varianten montierbar.

Remark: All shown options are available with only one holder.

Nota: E' sufficiente un solo corpo base per comporre tutte le combinazioni raffigurate.

**Hinweis: Sonderabmessungen und Abstechhalter für andere Maschinenhersteller auf Anfrage erhältlich.
 Ein Anfrageblatt hierzu finden Sie auf Seite 578 oder im Internet unter: www.arno.de/service/downloads**

*Remark: Custom made part-off holders for other machine manufacturers are available on request.
 Please complete enquiry sheet on page 578 or download this from www.arno.de/service/downloads*

*Nota: Adattatori speciali di differenti dimensioni e caratteristiche disponibili a richiesta.
 Vedere modulo richiesta a Pagina 578 o download del modulo da: www.arno.de/service/downloads*

--> Anwendungshinweise finden Sie auf S. 588/589/590

--> For application reference please see page 588/589/590

--> Per suggerimenti tecnici vedere pagina 588/589/590

BMT - mit Innenkühlung und ACS / BMT - with internal coolant and ACS / BMT - con refrigerazione interna e ACS

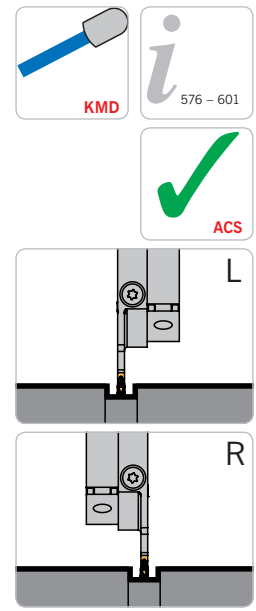
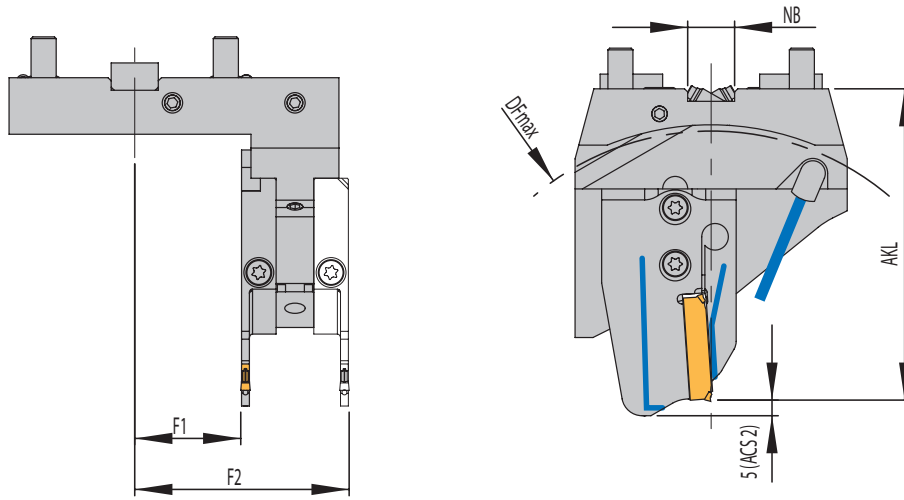

Rechter Halter und linkes Modul montiert
 Rechtes Modul alternativ
 Right holder and left module shown
 Right module alternative
 Adattatore destro e modulo sinistro in figura
 Modulo destro alternativa



Grundhalter / Basic holder / Adattore

Bezeichnung Designation Articolo	NB	F1	F2	Modul Module Modulo	PG 43
HDD-BMT45-SD-ACS	15	33,8	68,3	MSA-...-ACS.	●
HDD-BMT55-SD-ACS	15	46,3	80,8	MSA-...-ACS.	●
HDD-BMT55-SDL-ACSØ	15	46,3	80,8	MSA-...-ACS.	●
HDD-BMT55-SD-150-ACSØ	15	46,3	80,8	MSA-...-ACS.	●
HDD-BMT65-SD-ACS	18	48,8	83,3	MSA-...-ACS.	●

Modul / Module / Modulo

DF_{max} = Maximaler Futterdurchmesser und AKL = Auskraglänge bei Modul MSA-... / DF_{max} = maximum chuck diameter and AKL = Overhang length with modules MSA-... / DF_{max} = Diametro max mandrino e AKL = Lunghezza totale con modulo MSA-...

Bezeichnung Designation Articolo	BMT45...		BMT55...		BMT55...-150		BMT65...	
	AKL	DF_{max}	AKL	DF_{max}	AKL	DF_{max}	AKL	DF_{max}
MSA-...-32-ACS.	84,0	140	114,5	185	134,5	225	131,5	215
MSA-...-44-ACS.	89,0	150	119,5	195	139,5	235	136,5	225
MSA-...-52-ACS.	99,5	170	130,0	215	150,0	255	147,0	245
MSA-...-65-ACS.	99,5	170	130,0	215	150,0	255	147,0	245
MSA-...-69-ACS.	101,5	175	132,0	220	152,0	260	149,0	250
MSA-...-80-ACS.	107,0	185	137,5	230	157,5	270	154,5	260
MSA-...-90-ACS.	112,0	195	142,5	240	162,5	280	159,5	270
MSA-...-105-ACS.	120,0	210	150,5	255	170,5	295	167,5	285

Hinweis: Passende Module finden Sie im Kapitel SA (Seite 114 bis 128)

Remark: For modules to suit please see chapter SA (Page 114 to 128)

Nota: Per i moduli abbinabili vedere pagine da 114 a 128







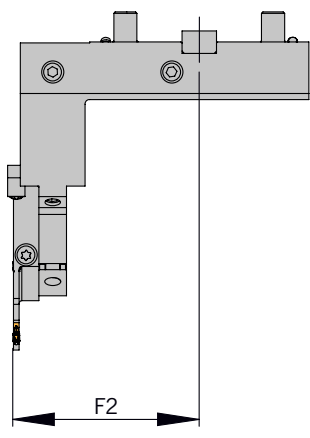
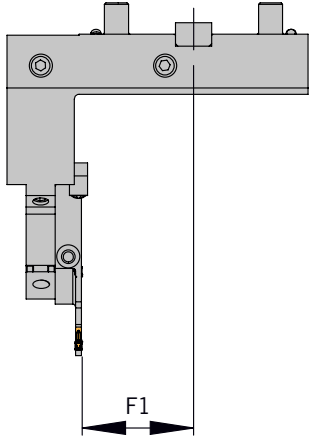
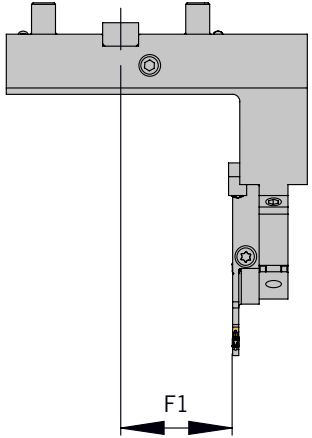
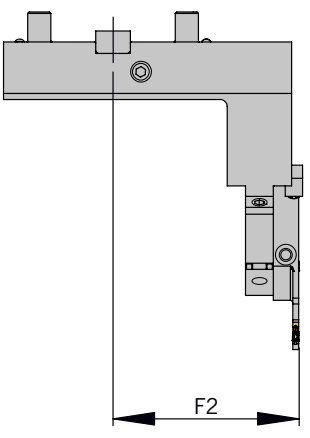

Ersatzteile / Spare Parts / Ricambi

Trägerwerkzeug Holder Utensile	Schraube für Modul Screw for module Vite per modulo	Schlüssel Key Chiave	O-Ring O-ring O-Ring	Kühlmitteldüse Coolant jet Ugello refrigerante
HDD-BMT45-SD	AS 0070	T5220-IP	OR 7X1,5 P	KMD 0825-3E
HDD-BMT55-SD.	AS 0070	T5220-IP	OR 8X1,5 P	KMD 0825-3E
HDD-BMT65-SD	AS 0070	T5220-IP	OR 9X1,5 P	KMD 0825-3E

Ersatzteile / Spare Parts / Ricambi

Modul Module Modulo	Schraube für Modul Screw for module Vite per modulo	Schlüssel Key Chiave
MSA-...-	SA5T	T5220-IP

Einbaumöglichkeiten / Assembly options / Combinazioni di montaggio

Linker Halter Left-hand holder Adattatore sinistro		Rechter Halter Right-hand holder Adattatore destro	
HDD-BMT55-SDL-ACS	HDD-BMT55-SDL-ACS	HDD-BMT45-SD-ACS	HDD-BMT45-SD-ACS
		HDD-BMT55-SD-ACS	HDD-BMT55-SD-ACS
		HDD-BMT55-SD-150-ACS	HDD-BMT55-SD-150-ACS
		HDD-BMT65-SD-ACS	HDD-BMT65-SD-ACS
			
Linkes Modul montiert Left module shown Modulo sinistro in figura	Rechtes Modul montiert Right module shown Modulo destro in figura	Linkes Modul montiert Left module shown Modulo sinistro in figura	Rechtes Modul montiert Right module shown Modulo destro in figura
			
Einbaulage normal Normal assembly Montaggio normale	Einbaulage normal Normal assembly Montaggio normale	Einbaulage normal Normal assembly Montaggio normale	Einbaulage normal Normal assembly Montaggio normale
			
Einbaulage Überkopf Upside down assembly Montaggio invertito	Einbaulage Überkopf Upside down assembly Montaggio invertito	Einbaulage Überkopf Upside down assembly Montaggio invertito	Einbaulage Überkopf Upside down assembly Montaggio invertito

Hinweis: Sonderabmessungen und Abstechhalter für andere Maschinenhersteller auf Anfrage erhältlich. Ein Anfrageblatt hierzu finden Sie auf Seite 578 oder im Internet unter: www.arno.de/service/downloads

Remark: Custom made part-off holders for other machine manufacturers are available on request. Please complete enquiry sheet on page 578 or download this from www.arno.de/service/downloads

Nota: Adattori speciali di differenti dimensioni e caratteristiche disponibili a richiesta. Vedere modulo richiesta a Pagina 578 o download del modulo da: www.arno.de/service/downloads

--> Anwendungshinweise finden Sie auf S. 588/589/590
 --> For application reference please see page 588/589/590
 --> Per suggerimenti tecnici vedere pagina 588/589/590

HDD - mit Innenkühlung und ACS / HDD - with internal coolant and ACS / HDD - con refrigerazione interna e ACS

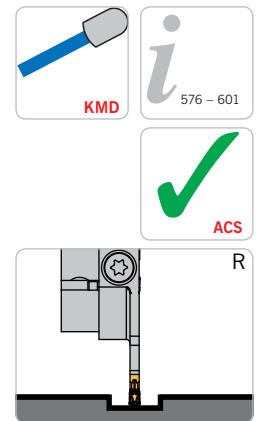
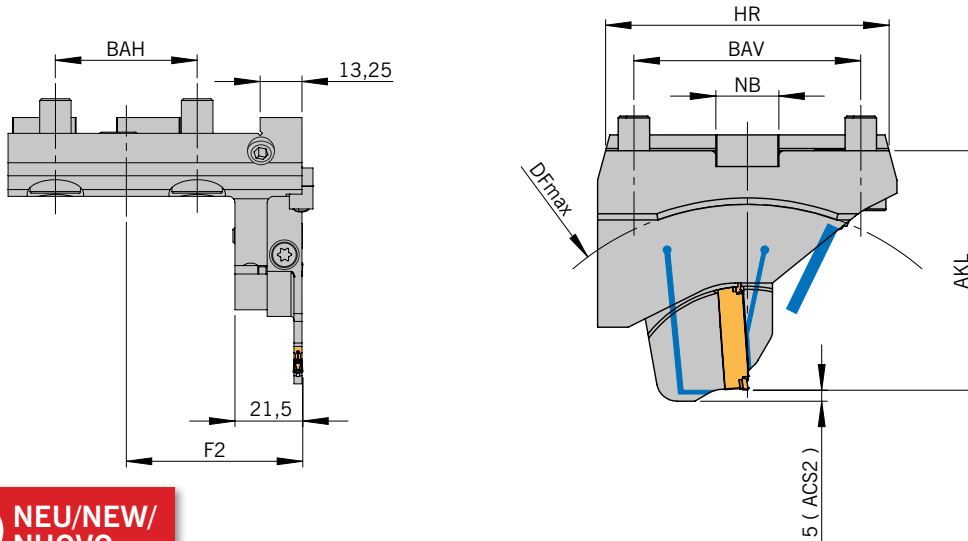

Rechter Halter und rechtes Modul montiert
 Right holder and right module shown
 Adattatore destro e modulo destro in figura



Grundhalter / Basic holder / Adattore

Bezeichnung Designation Articolo	BAH	BAV	HR	NB	F2	Modul Module Modulo	PG 43
HDD-45-72-R-MSA-SR-ACS	45	72	90	20	56	MSA-SR-...-ACS.	●
HDD-55-80-R-MSA-SR-ACS	55	80	97	20	71	MSA-SR-...-ACS.	●

Modul / Module / Modulo

DF_{max} = Maximaler Futterdurchmesser und **AKL** = Auskräglänge bei Modul MSA-... / **DF_{max}** = maximum chuck diameter and **AKL** = Overhang length with modules MSA-... / **DF_{max}** = Diametro max mandrino e **AKL** = Lunghezza totale con modulo MSA-...

Bezeichnung Designation Articolo	HDD45...		HDD55...	
	AKL	DF _{max}	AKL	DF _{max}
MSA-...-32-ACS.	60,5	85	117,0	180
MSA-...-44-ACS.	65,5	95	122,0	190
MSA-...-52-ACS.	76,0	115	132,5	210
MSA-...-65-ACS.	76,0	115	132,5	210
MSA-...-69-ACS.	78,0	120	134,5	215
MSA-...-80-ACS.	83,5	130	140,0	225
MSA-...-90-ACS.	88,5	140	145,0	235
MSA-...-105-ACS.	96,5	155	153,0	250

Hinweis: Passende Module finden Sie im Kapitel SA (Seite 114 bis 128)

Remark: For modules to suit please see chapter SA (Page 114 to 128)

Nota: Per I moduli abbinabili vedere pagine da 114 a 128



Ersatzteile / Spare Parts / Ricambi

Trägerwerkzeug Holder Utensile	Schraube für Modul Screw for module Vite per modulo	Schlüssel Key Chiave	O-Ring O-ring O-ring	Kühlmitteldüse Coolant jet Ugello refrigerante	Verschluss-Stift Locking pin Spina bloccaggio
HDD-45-72-R-MSA-SR-ACS	AS 0070	T5220-IP	OR 9X1,5 P	KMD 0820-4BJ	ZS0820G
HDD-55-80-R-MSA-SR-ACS	AS 0070	T5220-IP	OR 22X3,5P	KMD 0820-4BJ	ZS0820G

Ersatzteile / Spare Parts / Ricambi

Modul Module Modulo	Schraube für Modul Screw for module Vite per modulo	Schlüssel Key Chiave
MSA-...-	SA5T	T5220-IP

Einbaumöglichkeiten / Assembly options / Combinazioni di montaggio

Rechtes Modul montiert <i>Right module shown</i> Modulo destro in figura
HDD-45-72-R-MSA-SR-ACS
HDD-55-80-R-MSA-SR-ACS

Einbaulage normal <i>Normal assembly</i> Montaggio normale

Einbaulage Überkopf <i>Upside down assembly</i> Montaggio invertito

Hinweis: Mit einem Halter sind alle abgebildeten Varianten montierbar.

Remark: All shown options are available with only one holder.

Nota: E' sufficiente un solo corpo base per comporre tutte le combinazioni raffigurate.

**Hinweis: Sonderabmessungen und Abstechhalter für andere Maschinenhersteller auf Anfrage erhältlich.
Ein Anfrageblatt hierzu finden Sie auf Seite 578 oder im Internet unter: www.arno.de/service/downloads**

*Remark: Custom made part-off holders for other machine manufacturers are available on request.
Please complete enquiry sheet on page 578 or download this from www.arno.de/service/downloads*

*Nota: Adattatori speciali di differenti dimensioni e caratteristiche disponibili a richiesta.
Vedere modulo richiesta a Pagina 578 o download del modulo da: www.arno.de/service/downloads*

--> **Anwendungshinweise finden Sie auf S. 588/589/590**

--> *For application reference please see page 588/589/590*

--> *Per suggerimenti tecnici vedere pagina 588/589/590*

BMT - mit Innenkühlung und ACS / BMT - with internal coolant and ACS / BMT - con refrigerazione interna e ACS

Grundhalter / Basic holders / Corpo utensili

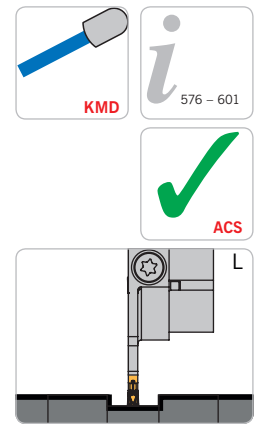
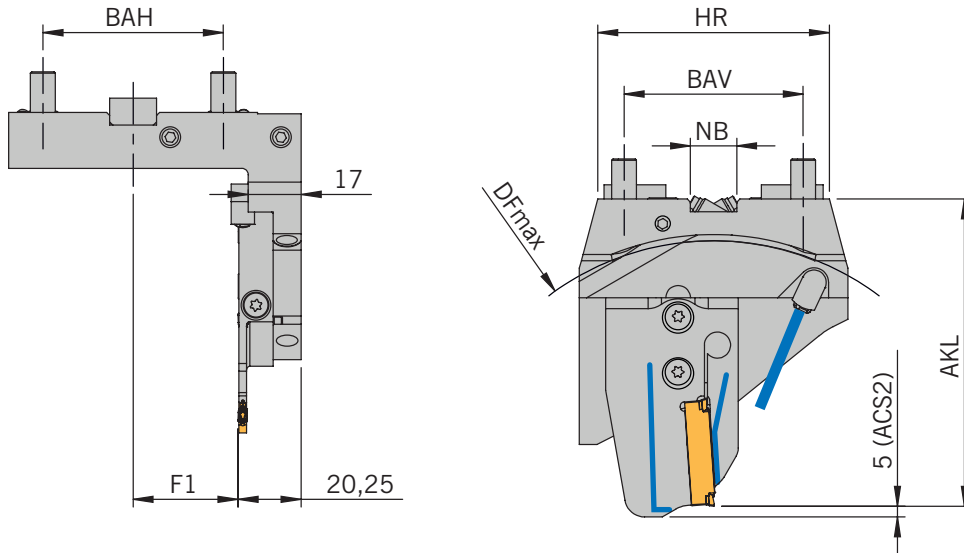

Rechter Halter und linkes Modul montiert
 Halter höhenstellbar
 Right holder and left module shown
 Height adjustable holder
 Adattatore destro e modulo sinistro in figura
 Adattatore registrabile in altezza

Grundhalter / Basic holders / Corpo utensili

Bezeichnung Designation Articolo	BAH	BAV	HR	NB	F1	Modul Module Modulo	PG 43
HDD-58-58-R-MSA-SL-ACS	58	58	75	12	33,8	MSA-SL-...-ACS.	●

Modul / Module / Modulo

DF_{max} = Maximaler Futterdurchmesser und **AKL** = Ausraglänge bei Modul MSA-... / **DF_{max}** = maximum chuck diameter and **AKL** = Overhang length with modules MSA-... / **DF_{max}** = Diametro max mandrino e **AKL** = Lunghezza totale con modulo MSA-..

Bezeichnung Designation Articolo	HDD58...	
	AKL	DF _{max}
MSA-...-32-ACS.	84,0	140
MSA-...-44-ACS.	89,0	150
MSA-...-52-ACS.	99,5	170
MSA-...-65-ACS.	99,5	170
MSA-...-69-ACS.	101,5	175
MSA-...-80-ACS.	107,0	185
MSA-...-90-ACS.	112,0	195
MSA-...-105-ACS.	120,0	210

Hinweis: Passende Module finden Sie im Kapitel SA (Seite 114 bis 128)

Remark: For modules to suit please see chapter SA (Page 114 to 128)

Nota: Per I moduli abbinabili vedere pagine da 114 a 128

Ersatzteile / Spare Parts / Ricambi

Trägerwerkzeug Holder Utensile	Schraube für Modul Screw for module Vite per modulo	Schlüssel Key Chiave	O-Ring O-ring O-Ring	Kühlmitteldüse Coolant jet Ugello refrigerante
HDD-58-58-R-MSA-SL-ACS	AS 0070	T5220-IP	OR 7X1,5 P	KMD 0820-4BJ

Ersatzteile / Spare Parts / Ricambi

Modul Module Modulo	Schraube für Modul Screw for module Vite per modulo	Schlüssel Key Chiave
MSA-...-	SA5T	T5220-IP

Einbaumöglichkeiten / Assembly options / Combinazioni di montaggio

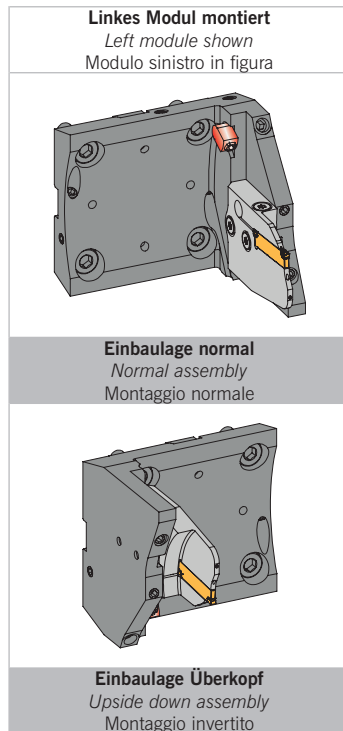

Hinweis: Sonderabmessungen und Abstechhalter für andere Maschinenhersteller auf Anfrage erhältlich. Ein Anfrageblatt hierzu finden Sie auf Seite 578 oder im Internet unter: www.arno.de/service/downloads

Remark: Custom made part-off holders for other machine manufacturers are available on request. Please complete enquiry sheet on page 578 or download this from www.arno.de/service/downloads

Nota: Adattatori speciali di differenti dimensioni e caratteristiche disponibili a richiesta. Vedere modulo richiesta a Pagina 578 o download del modulo da: www.arno.de/service/downloads

--> **Anwendungshinweise finden Sie auf S. 588/589/590**
--> *For application reference please see page 588/589/590*
--> *Per suggerimenti tecnici vedere pagina 588/589/590*

HHAR - mit ACS / HHAR - with ACS / HHAR - con ACS

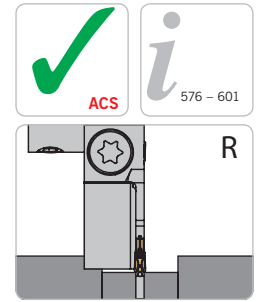
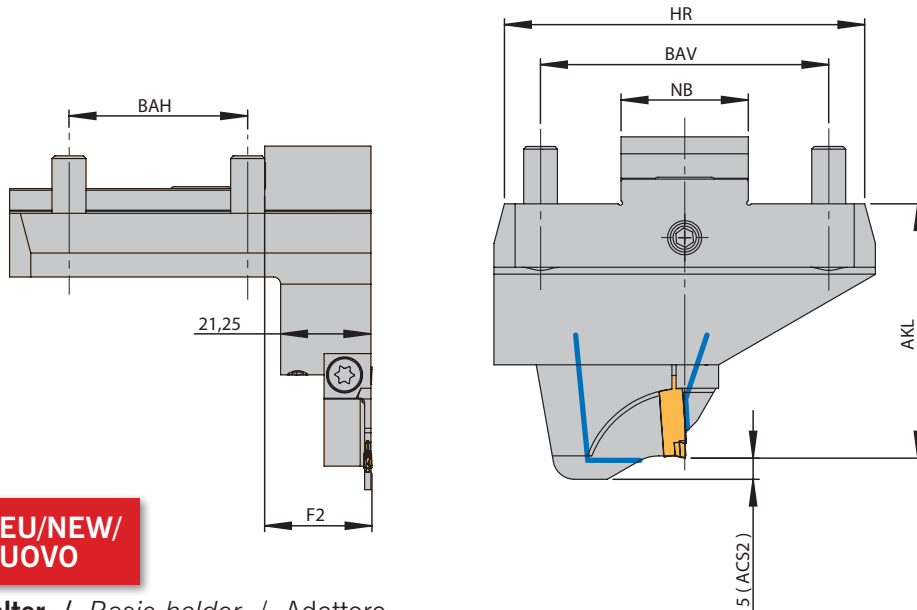

Rechter Halter und
rechtes Modul montiert
Right holder and right module shown
Adattatore destro e modulo destro in figura



Grundhalter / Basic holder / Adattore

Bezeichnung Designation Articolo	BAH	BAV	HR	NB	F2	Modul Module Modulo	PG 43
HHAR-42-68-R-MSA-SR-ACS	42	68	85	30	25,3	MSA-SR-...-ACS.	●

Modul / Module / Modulo

DF_{max} = Maximaler Futterdurchmesser und AKL = Ausraglänge bei Modul MSA-... / DF_{max} = maximum chuck diameter and AKL = Overhang length with modules MSA-... / DF_{max} = Diametro max mandrino e AKL = Lunghezza totale con modulo MSA-...

Bezeichnung Designation Articolo	HHAR...	
	AKL	DF _{max}
MSA-...-32-ACS.	60,0	85
MSA-...-44-ACS.	65,0	95
MSA-...-52-ACS.	75,5	115
MSA-...-65-ACS.	75,5	115
MSA-...-69-ACS.	77,5	120
MSA-...-80-ACS.	83,0	130
MSA-...-90-ACS.	88,0	140
MSA-...-105-ACS.	96,0	155

Hinweis: Passende Module finden Sie im Kapitel SA (Seite 114 bis 128)

Remark: For modules to suit please see chapter SA (Page 114 to 128)

Nota: Per i moduli abbinabili vedere pagine da 114 a 128

Ersatzteile / Spare Parts / Ricambi

Trägerwerkzeug Holder Utensile	Schraube für Modul Screw for module Vite per modulo	Schlüssel Key Chiave	O-Ring O-ring O-Ring
HHAR-42-68-R-MSA-SR-ACS	SA5T	T5220-IP	OR 10,82X1,78P

Ersatzteile / Spare Parts / Ricambi

Modul Module Modulo	Schraube für Modul Screw for module Vite per modulo	Schlüssel Key Chiave
MSA-...-	SA5T	T5220-IP

Einbaumöglichkeiten / Assembly options / Combinazioni di montaggio



**Hinweis: Sonderabmessungen und Abstechhalter für andere Maschinenhersteller auf Anfrage erhältlich.
Ein Anfrageblatt hierzu finden Sie auf Seite 578 oder im Internet unter: www.arno.de/service/downloads**

*Remark: Custom made part-off holders for other machine manufacturers are available on request.
Please complete enquiry sheet on page 578 or download this from www.arno.de/service/downloads*

*Nota: Adattatori speciali di differenti dimensioni e caratteristiche disponibili a richiesta.
Vedere modulo richiesta a Pagina 578 o download del modulo da: www.arno.de/service/downloads*

HABC.. - mit Innenkühlung und ACS
 HABC.. - with internal coolant and ACS
 HABC.. - con refrigerazione interna e ACS

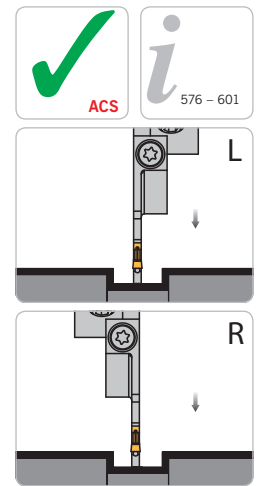
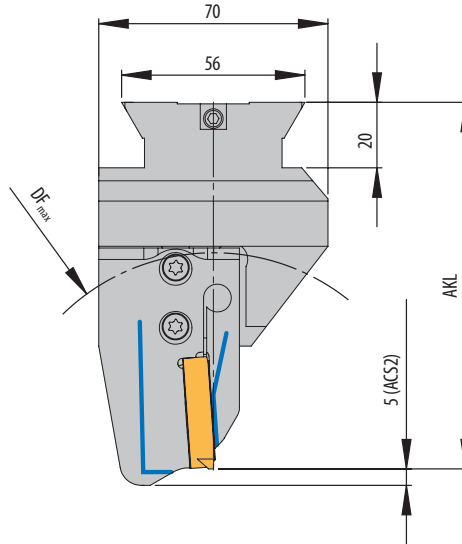
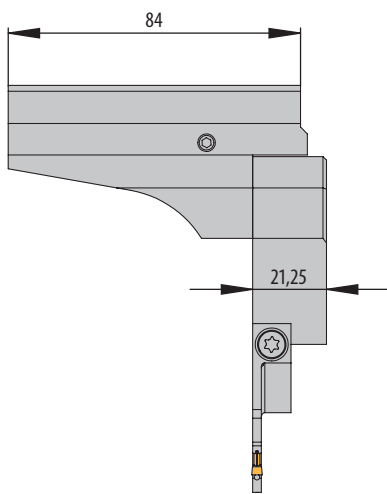

Rechter Halter und linkes Modul montiert
 Halter höhenstellbar
 Right holder and left module shown
 Height adjustable holder
 Adattatore destro e modulo sinistro in figura
 Adattatore registrabile in altezza

Grundhalter / Basic holder / Adattore

Bezeichnung Designation Articolo	F1	F2	Modul Module Modulo	PG 43
HABC-R-7-MSA-SL-ACS	21,5	-	MSA-SL-...-ACS.	●
HABC-R-7-MSA-SR-ACS	-	21,5	MSA-SR-...-ACS.	●

Modul / Module / Modulo

DF_{max} = Maximaler Futterdurchmesser und **AKL** = Auskraglänge bei Modul MSA-... / **DF_{max}** = maximum chuck diameter and **AKL** = Overhang length with modules MSA-... / **DF_{max}** = Diametro max mandrino e **AKL** = Lunghezza totale con modulo MSA-...

Bezeichnung Designation Articolo	HABC...	
	AKL	DF _{max}
MSA-...-32-ACS.	96,5	100
MSA-...-44-ACS.	101,5	110
MSA-...-52-ACS.	112,0	130
MSA-...-65-ACS.	112,0	130
MSA-...-69-ACS.	114,0	135

Hinweis: Passende Module finden Sie im Kapitel SA (Seite 114 bis 128)

Remark: For modules to suit please see chapter SA (Page 114 to 128)

Nota: Per I moduli abbinabili vedere pagine da 114 a 128

9 Ersatzteile / Spare Parts / Ricambi

Modul Module Modulo	Schraube für Modul Screw for module Vite per modulo	Schlüssel Key Chiave
HABC-R-7-MSA-...-ACS	AS 0070	T5220-IP

Ersatzteile / Spare Parts / Ricambi

Modul Module Modulo	Schraube für Modul Screw for module Vite per modulo	Schlüssel Key Chiave
MSA-...-	SA5T	T5220-IP

Einbaumöglichkeiten / Assembly options / Combinazioni di montaggio

Rechter Halter Right-hand holder Adattatore destro	
HABC-R-7-MSA-SL-ACS	HABC-R-7-MSA-SR-ACS
Linkes Modul montiert <i>Left module shown</i> Modulo sinistro in figura	Rechtes Modul montiert <i>Right module shown</i> Modulo destro in figura
Einbaulage normal <i>Normal assembly</i> Montaggio normale	Einbaulage normal <i>Normal assembly</i> Montaggio normale
Einbaulage Überkopf <i>Upside down assembly</i> Montaggio invertito	Einbaulage Überkopf <i>Upside down assembly</i> Montaggio invertito

Hinweis: Sonderabmessungen und Abstechhalter für andere Maschinenhersteller auf Anfrage erhältlich. Ein Anfrageblatt hierzu finden Sie auf Seite 578 oder im Internet unter: www.arno.de/service/downloads

Remark: Custom made part-off holders for other machine manufacturers are available on request. Please complete enquiry sheet on page 578 or download this from www.arno.de/service/downloads

Nota: Adattatori speciali di differenti dimensioni e caratteristiche disponibili a richiesta. Vedere modulo richiesta a Pagina 578 o download del modulo da: www.arno.de/service/downloads

--> Anwendungshinweise finden Sie auf S. 586
 --> For application reference please see page 586
 --> Per suggerimenti tecnici vedere pagina 586

HTR45 - mit Innenkühlung / HTR45 - with internal coolant /
HTR45 - con refrigerazione interna

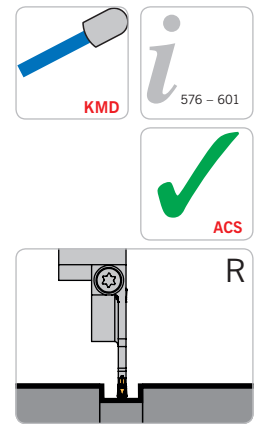
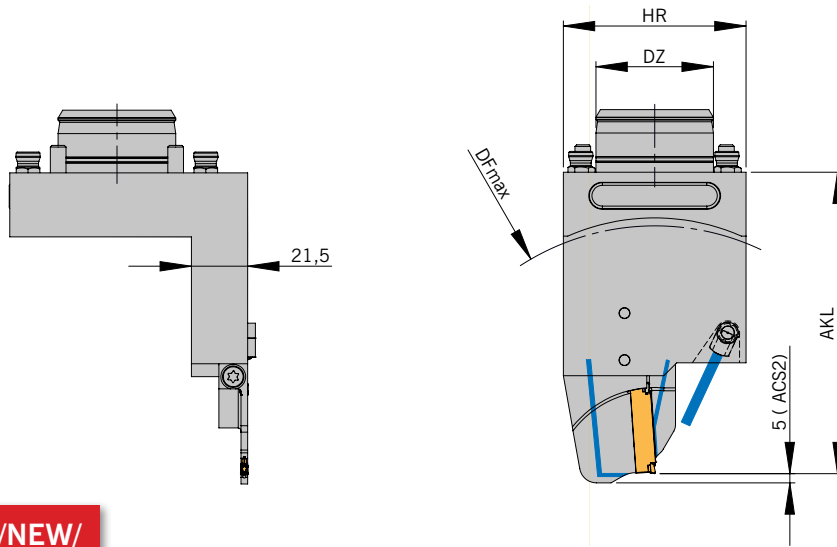

Rechter Halter und
 rechtes Modul montiert
 Right holder and right module shown
 Adattatore destro e modulo destro in figura



Grundhalter / Basic holder / Adattore

Bezeichnung Designation Articolo	DZ	F2	HR	Modul Module Modulo	PG 43
HTR45-R-W7040135-MSA-SR-ACS	45	50,3	70	MSA-SR-...-ACS.	●

Modul / Module / Modulo

DF_{max} = Maximaler Futterdurchmesser und **AKL** = Auskraglänge bei Modul MSA-... / **DF_{max}** = maximum chuck diameter and **AKL** = Overhang length with modules MSA-... / **DF_{max}** = Diametro max mandrino e **AKL** = Lunghezza totale con modulo MSA-...

Bezeichnung Designation Articolo	HTR45 für TNK42 HTR45 for TNK42 HTR45 per TNK42		HTR45 für TNK65/ABC65 HTR45 for TNK65/ABC65 HTR45 per TNK65/ABC65	
	AKL	DF _{max}	AKL	DF _{max}
MSA-...-44-ACS.	105	170	-	-
MSA-...-65-ACS	-	-	115,5	185

Hinweis: Passende Module finden Sie im Kapitel SA (Seite 114 bis 128)

Remark: For modules to suit please see chapter SA (Page 114 to 128)

Nota: Per I moduli abbinabili vedere pagine da 114 a 128

Ersatzteile / Spare Parts / Ricambi





Trägerwerkzeug Holder Utensile	Schraube für Modul Screw for module Vite per modulo	Schlüssel Key Chiave	Kühlmitteldüse Coolant jet Ugello refrigerante	Verschluss-Stift Locking pin Spina bloccaggio
HTR45-R-...-MSA-...	AS 0070	T5220-IP	KMD 0820-4BJ	ZS0820G

Ersatzteile / Spare Parts / Ricambi

Modul Module Modulo	Schraube für Modul Screw for module Vite per modulo	Schlüssel Key Chiave
MSA-...-	SA5T	T5220-IP

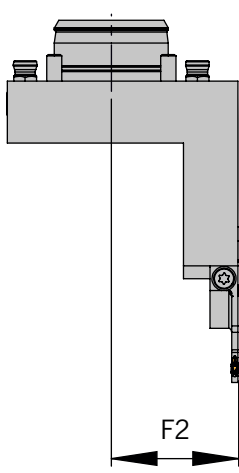

Einbaumöglichkeiten / Assembly options / Combinazioni di montaggio

<p>Rechter Halter Right-hand holder Adattatore destro</p> <p>HTR45-R-W7040135-MSA-SR-ACS</p>  <p>F2</p>
<p>Rechtes Modul montiert Right module shown Modulo destro in figura</p> 
<p>Einbaulage normal Normal assembly Montaggio normale</p> 
<p>Einbaulage Überkopf Upside down assembly Montaggio invertito</p> 

**Hinweis: Sonderabmessungen und Abstechhalter für andere Maschinenhersteller auf Anfrage erhältlich.
Ein Anfrageblatt hierzu finden Sie auf Seite 578 oder im Internet unter: www.arno.de/service/downloads**

*Remark: Custom made part-off holders for other machine manufacturers are available on request.
Please complete enquiry sheet on page 578 or download this from www.arno.de/service/downloads*

*Nota: Adattatori speciali di differenti dimensioni e caratteristiche disponibili a richiesta.
Vedere modulo richiesta a Pagina 578 o download del modulo da: www.arno.de/service/downloads*

HTR45 - mit Innenkühlung / HTR45 - with internal coolant / HTR45 - con refrigerazione interna

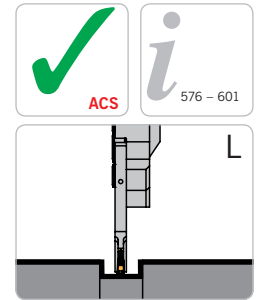
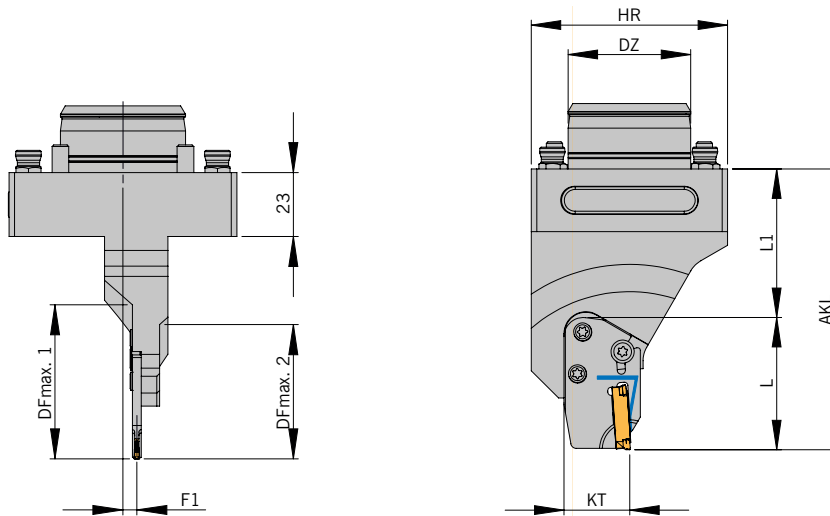

Linkes Modul montiert
 Left module shown
 Modulo sinistro in figura



Grundhalter / Basic holder / Adattore

Bezeichnung Designation Articolo	DZ	F1	HR	KT	Modul Module Modulo	PG 43
HTR45-R-W7040134-MSA-IL-ACS0	45	5	72	24	MSA-IL-...-ACS.	●

Modul / Module / Modulo

DF_{max} = Maximaler Futterdurchmesser und AKL = Auskräglänge bei Modul MSA-... / DF_{max} = maximum chuck diameter and AKL = Overhang length with modules MSA-... / DF_{max} = Diametro max mandrino e AKL = Lunghezza totale con modulo MSA-...

Bezeichnung Designation Articolo	HTR45 für TNL18 HTR45 for TNL18 HTR45 per TNL18			HTR45 für TNL32 HTR45 for TNL32 HTR45 per TNL32		
	AKL	$DF_{max 1}$	$DF_{max 2}$	AKL	$DF_{max 1}$	$DF_{max 2}$
MSA-IL-SA2402-L48,5-20-ACS.	103	110	95	-	-	-
MSA-IL-SA2402-L56,0-32-ACS1	-	-	-	110,5	120	105

Hinweis: Passende Module finden Sie im Kapitel SA (Seite 114 bis 128)

Remark: For modules to suit please see chapter SA (Page 114 to 128)

Nota: Per I moduli abbinabili vedere pagine da 114 a 128

Ersatzteile / Spare Parts / Ricambi

Trägerwerkzeug Holder Utensile	Schraube für Modul Screw for module Vite per modulo	Schlüssel Key Chiave
HTR45-R-...-MSA-IL-ACS	2x AS0049 / 1x AS0050*	T5120-IP

* Alternativ AS 0050D (doppelseitig IP20)

* Alternatively AS 0050D (double sided IP20)

* Alternativo AS 0050D (bilateralmente IP20)



Einbaumöglichkeiten / Assembly options / Combinazioni di montaggio

<p>Rechter Halter Right-hand holder Adattatore destro</p> <p>HTR45-R-W7040134-MSA-IL-ACS</p> 
<p>Linkes Modul montiert Left module shown Modulo sinistro in figura</p> 
<p>Einbaulage normal Normal assembly Montaggio normale</p> 
<p>Einbaulage Überkopf Upside down assembly Montaggio invertito</p>

**Hinweis: Sonderabmessungen und Abstechhalter für andere Maschinenhersteller auf Anfrage erhältlich.
Ein Anfrageblatt hierzu finden Sie auf Seite 578 oder im Internet unter: www.arno.de/service/downloads**

*Remark: Custom made part-off holders for other machine manufacturers are available on request.
Please complete enquiry sheet on page 578 or download this from www.arno.de/service/downloads*

*Nota: Adattatori speciali di differenti dimensioni e caratteristiche disponibili a richiesta.
Vedere modulo richiesta a Pagina 578 o download del modulo da: www.arno.de/service/downloads*

--> Anwendungshinweise finden Sie auf S. 600/601

--> For application reference please see page 600/601

--> Per suggerimenti tecnici vedere pagina 600/601

HTR45 - mit Innenkühlung und ACS für KSA-Steckklinge /
HTR45 - with internal coolant and ACS for KSA blades /
HTR45 - con refrigerazione interna e ACS per lame KSA

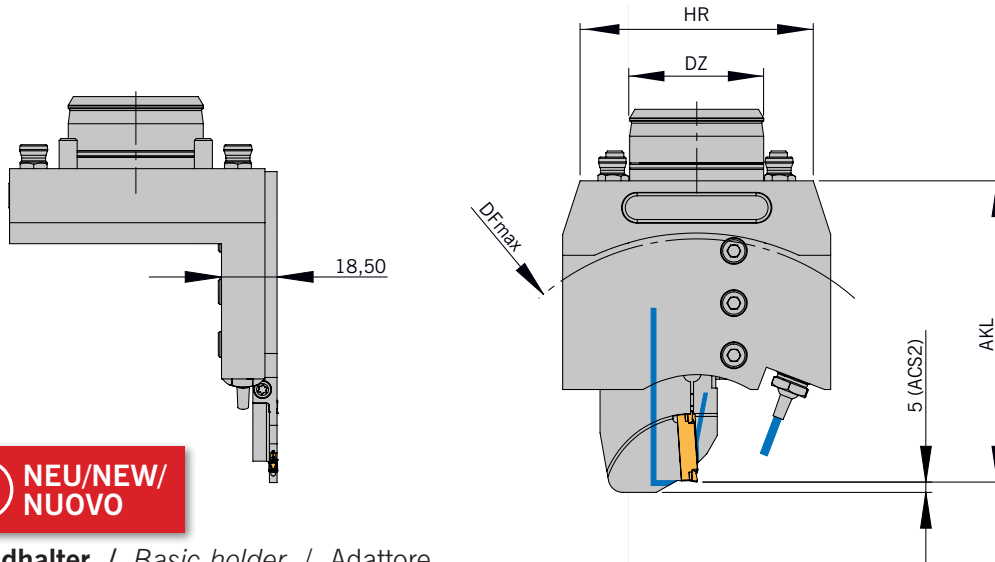
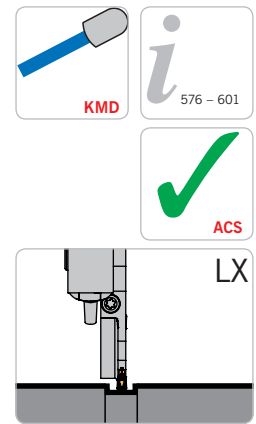

Rechter Halter und Klinge LX montiert
 Right holder and blade LX fixed
 Adattatore destro e lama LX montata



Grundhalter / Basic holder / Adattore

Bezeichnung Designation Articolo	DZ	F2	HR	Modul Module Modulo	PG 43
HTR45-R-W7040098-KSA-32LX-ACS	45	47,3	78.3	KSA-TR-3208LX-...-ACS.	●

Steckklinge / Part-off blade / Lama da taglio

DF_{max} = Maximaler Futterdurchmesser und **AKL** = Auskraglänge bei Klinge KSA-... / **DF_{max}** = maximum chuck diameter and **AKL** = Overhang length with blades KSA-.. / **DF_{max}** = Diametro max mandrino e **AKL** = Lunghezza totale con lame KSA-..

Bezeichnung Designation Articolo	HTR45	
	AKL	DF _{max}
KSA-TR-3208LX-SA2403-44-ACS2	101	160
KSA-TR-3208LX-SA3503-65-ACS2	111	180

Hinweis: Passende Klingen finden Sie im Kapitel SA (Seite 94 bis 111)
 Remark: For blades to suit please see chapter SA (Page 94 to 111)
 Nota: Per I lame abbinabili vedere pagine da 94 a 111





Ersatzteile / Spare Parts / Ricambi

Trägerwerkzeug Holder Utensile	Klemmleiste Clamping strip Morsettiera	Klemmleiste 2 Clamping strip 2 Morsettiera 2	O-Ring O-ring O-Ring	O-Ring 2 O-ring 2 O-Ring 2
HTR45-R-...-KSA-..	60AB3444	W67310.0624	OR 18,77X1,78 P	OR 40X1,6 P

Ersatzteile / Spare Parts / Ricambi

Klinge Blade Lama	Spannschraube für Klemme Span screw for clamp Vite di arco per staffa	Schlüssel Key Chiave
KSA-TR-3208LX-..	AS 0022	T5215-IP

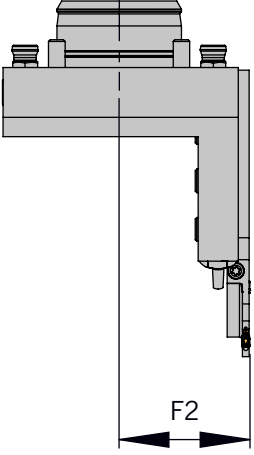
Einbaumöglichkeiten / Assembly options / Combinazioni di montaggio

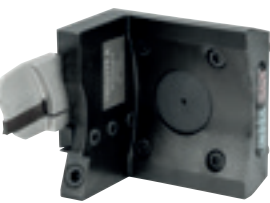
<p>Rechter Halter Right-hand holder Adattatore destro</p> <p>HTR45-R-W7040098-KS-32LX-ACS</p> 
<p>Klinge LX montiert Blade LX shown Lama LX in figura</p> 
<p>Einbaulage normal Normal assembly Montaggio normale</p> 
<p>Einbaulage Überkopf Upside down assembly Montaggio invertito</p>

Hinweis: Sonderabmessungen und Abstechhalter für andere Maschinenhersteller auf Anfrage erhältlich. Ein Anfrageblatt hierzu finden Sie auf Seite 578 oder im Internet unter: www.arno.de/service/downloads

Remark: Custom made part-off holders for other machine manufacturers are available on request. Please complete enquiry sheet on page 578 or download this from www.arno.de/service/downloads

Nota: Adattatori speciali di differenti dimensioni e caratteristiche disponibili a richiesta. Vedere modulo richiesta a Pagina 578 o download del modulo da: www.arno.de/service/downloads

--> **Anwendungshinweise finden Sie auf S. 599**
 --> *For application reference please see page 599*
 --> *Per suggerimenti tecnici vedere pagina 599*

HMAZ - mit Innenkühlung und ACS / HMAZ - with internal coolant and ACS / HMAZ - con refrigerazione interna e ACS

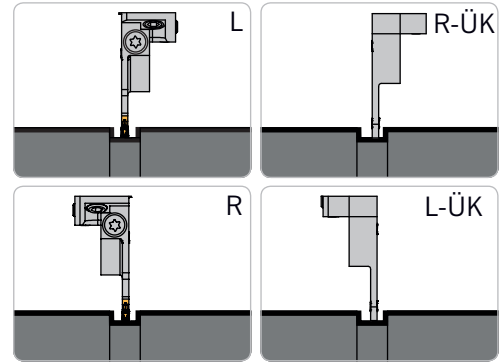
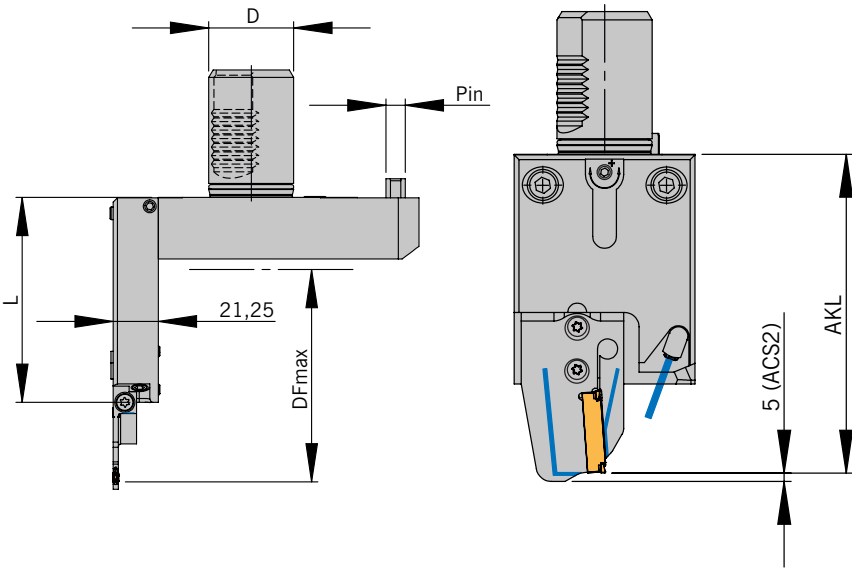

Linker Halter und linkes Modul montiert
 Halter höhenstellbar
 Left holder and left module shown
 Height adjustable holder
 Adattatore sinistro e
 modulo sinistro in figura
 Adattatore registrabile in altezza



Grundhalter / Basic holder / Adattore

Bezeichnung Designation Articolo	D	L	Pin	F1	F2	Modul Module Modulo	PG 43
HMAZ40L-A1-7-44-MSA-SR-SQT10-ACS	40	96,5	16	43,6	-	MSA-SR...ACS.	●
HMAZ40L-A1-7-65-MSA-SL-SQT10-ACS	40	96,5	16	-	65,3	MSA-SL...ACS.	●
HMAZ40L-A1-7-65-MSA-SR-ÜK-SQT10-ACS	40	96,5	16	-	65,3	MSA-SR...ACS.	●
HMAZ40L-A1-7-78-MSA-SR-ÜK-SQT15-ACS	40	132,5	20	-	78,3	MSA-SR...ACS.	●

Modul / Module / Modulo

DF_{max} = Maximaler Futterdurchmesser und AKL = Auskräglänge bei Modul MSA-... / DF_{max} = maximum chuck diameter and AKL = Overhang length with modules MSA-... / DF_{max} = Diametro max mandrino e AKL = Lunghezza totale con modulo MSA-...

Bezeichnung Designation Articolo	HMAZ40...-SQT10		HMAZ40...-SQT15	
	AKL	DF _{max}	AKL	DF _{max}
MSA-...-32-ACS.	118,5	185	154,5	255
MSA-...-44-ACS.	123,5	195	159,5	260
MSA-...-52-ACS.	134,0	215	170,0	280
MSA-...-65-ACS.	134,0	215	170,0	280
MSA-...-69-ACS.	136,0	220	172,0	285
MSA-...-80-ACS.	141,5	230	177,5	295
MSA-...-90-ACS.	146,5	240	182,5	305
MSA-...-105-ACS.	154,5	255	190,5	320

Hinweis: Passende Module finden Sie im Kapitel SA (Seite 114 bis 128)

Remark: For modules to suit please see chapter SA (Page 114 to 128)

Nota: Per i moduli abbinabili vedere pagine da 114 a 128

Ersatzteile / Spare Parts / Ricambi

Trägerwerkzeug Holder Utensile	Schraube für Modul Screw for module Vite per modulo	Schlüssel Key Chiave	Kühlmitteldüse Coolant jet Ugello refrigerante	Verschluss-Stift Locking pin Spina bloccaggio
HMAZ40L..	AS 0070	T5220-IP	KMD 0820-4BJ	ZS0820G

Ersatzteile / Spare Parts / Ricambi

Modul Module Modulo	Schraube für Modul Screw for module Vite per modulo	Schlüssel Key Chiave
MSA-...-	SA5T	T5220-IP

Einbaumöglichkeiten / Assembly options / Combinazioni di montaggio

Linker Halter Left-hand holder Adattore sinistro			
HMAZ40L-A1-7-65-MSA-SL-SQT10-ACS	HMAZ40L-A1-7-65-MSA-SR-ÜK-SQT10-ACS	HMAZ40L-A1-7-44-MSA-SR-SQT10-ACS	HMAZ40L-A1-7-78-MSA-SR-ÜK-SQT15-ACS
HMAZ40L-A1-7-78-MSA-SL-SQT15-ACS	HMAZ40L-A1-7-78-MSA-SR-ÜK-SQT15-ACS		
Linkes Modul montiert Left module shown Modulo sinistro in figura	Rechtes Modul montiert Right module shown Modulo destro in figura	Linkes Modul montiert Left module shown Modulo sinistro in figura	Rechtes Modul montiert Right module shown Modulo destro in figura
Einbaulage normal Normal assembly Montaggio normale	Einbaulage Überkopf Upside down assembly Montaggio invertito	Einbaulage Überkopf Upside down assembly Montaggio invertito	Einbaulage normal Normal assembly Montaggio normale

Hinweis: Sonderabmessungen und Abstechhalter für andere Maschinenhersteller auf Anfrage erhältlich. Ein Anfrageblatt hierzu finden Sie auf Seite 578 oder im Internet unter: www.arno.de/service/downloads

Remark: Custom made part-off holders for other machine manufacturers are available on request. Please complete enquiry sheet on page 578 or download this from www.arno.de/service/downloads

Nota: Adattatori speciali di differenti dimensioni e caratteristiche disponibili a richiesta. Vedere modulo richiesta a Pagina 578 o download del modulo da: www.arno.de/service/downloads

HMAZ - mit Innenkühlung und ACS / HMAZ - with internal coolant and ACS / HMAZ - con refrigerazione interna e ACS

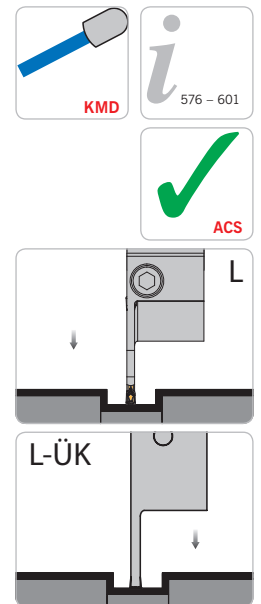
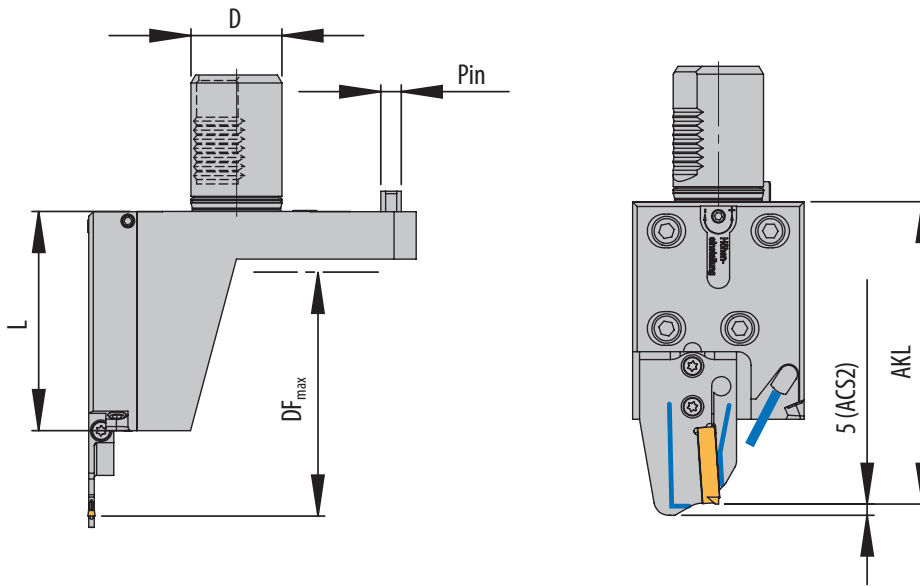

Linker Halter und linkes Modul montiert
Halter höhenstellbar
Left holder and left module shown
Height adjustable holder
Adattatore sinistro e modulo sinistro in figura
Adattatore regolabile in altezza

Grundhalter / Basic holder / Adattore

Bezeichnung Designation Articolo	D	L	Pin	F2	Modul Module Modulo	PG 43
HMAZ40L-7-65-MSA-SL-SQT10-1K	40	96,5	16	65,3	MSA-SL-...ACS.	●
HMAZ40L-7-65-MSA-SR-ÜK-SQT10-1K	40	96,5	16	65,3	MSA-SR-...ACS.	●
HMAZ40L-7-78-MSA-SL-SQT15-1K	40	132,5	20	78,3	MSA-SL-...ACS.	●
HMAZ40L-7-78-MSA-SR-ÜK-SQT15-1K	40	132,5	20	78,3	MSA-SR-...ACS.	●

Modul / Module / Modulo

DF_{max} = Maximaler Futterdurchmesser und **AKL** = Auskraglänge bei Modul MSA-... / **DF_{max}** = maximum chuck diameter and **AKL** = Overhang length with modules MSA-... / **DF_{max}** = Diametro max mandrino e **AKL** = Lunghezza totale con modulo MSA-...

Bezeichnung Designation Articolo	HMAZ40-7-65...		HMAZ40-7-78...	
	AKL	DF _{max}	AKL	DF _{max}
MSA-...-32-ACS.	118,5	190	154,5	245
MSA-...-44-ACS.	123,5	200	159,5	255
MSA-...-52-ACS.	134,0	220	170,0	275
MSA-...-65-ACS.	134,0	220	170,0	275
MSA-...-69-ACS.	136,0	225	172,0	280
MSA-...-80-ACS.	141,5	235	177,5	290
MSA-...-90-ACS.	146,5	245	182,5	300
MSA-...-105-ACS.	154,5	260	190,5	315

Hinweis: Passende Module finden Sie im Kapitel SA (Seite 114 bis 128)

Remark: For modules to suit please see chapter SA (Page 114 to 128)

Nota: Per I moduli abbinabili vedere pagine da 114 a 128

Ersatzteile / Spare Parts / Ricambi

Trägerwerkzeug Holder Utensile	Schraube für Modul Screw for module Vite per modulo	Schlüssel Key Chiave	Kühlmitteldüse Coolant jet Ugello refrigerante	Verschluss-Stift Locking pin Spina bloccaggio
HMAZ40L-..	AS 0070	T5220-IP	KMD 0820-4BJ	ZS0820G

Ersatzteile / Spare Parts / Ricambi

Modul Module Modulo	Schraube für Modul Screw for module Vite per modulo	Schlüssel Key Chiave
MSA-...-	SA5T	T5220-IP

Einbaumöglichkeiten / Assembly options / Combinazioni di montaggio

Linker Halter Left-hand holder Adattatore sinistro	
HMAZ40L-7-65-MSA-SL-SQT10-IK	HMAZ40L-7-65-MSA-SR-ÜK-SQT10-IK
HMAZ40L-7-78-MSA-SL-SQT15-IK	HMAZ40L-7-78-MSA-SR-ÜK-SQT15-IK
Linkes Modul montiert Left module shown Modulo sinistro in figura	Linkes Modul montiert Left module shown Modulo sinistro in figura
Einbaulage normal Normal assembly Montaggio normale	Einbaulage Überkopf Upside down assembly Montaggio invertito

Hinweis: Sonderabmessungen und Abstechhalter für andere Maschinenhersteller auf Anfrage erhältlich. Ein Anfrageblatt hierzu finden Sie auf Seite 578 oder im Internet unter: www.arno.de/service/downloads

Remark: Custom made part-off holders for other machine manufacturers are available on request. Please complete enquiry sheet on page 578 or download this from www.arno.de/service/downloads

Nota: Adattatori speciali di differenti dimensioni e caratteristiche disponibili a richiesta. Vedere modulo richiesta a Pagina 578 o download del modulo da: www.arno.de/service/downloads

Direktaufnahme Mazak - Für Monoblockhalter Abstechhalter und Direktaufnahmen

Flange mounted holder - For monoblock holders
 Attacchi base per Mazak - per steli monoblocco

Part-off holders and flange mounted holders
 Adattatori di troncatura e attacchi base

HMAZ - mit Innenkühlung und ACS / HMAZ - with internal coolant and ACS / HMAZ - con refrigerazione interna e ACS

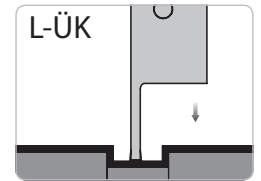
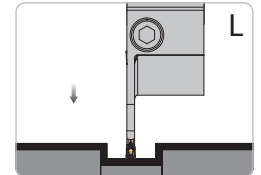
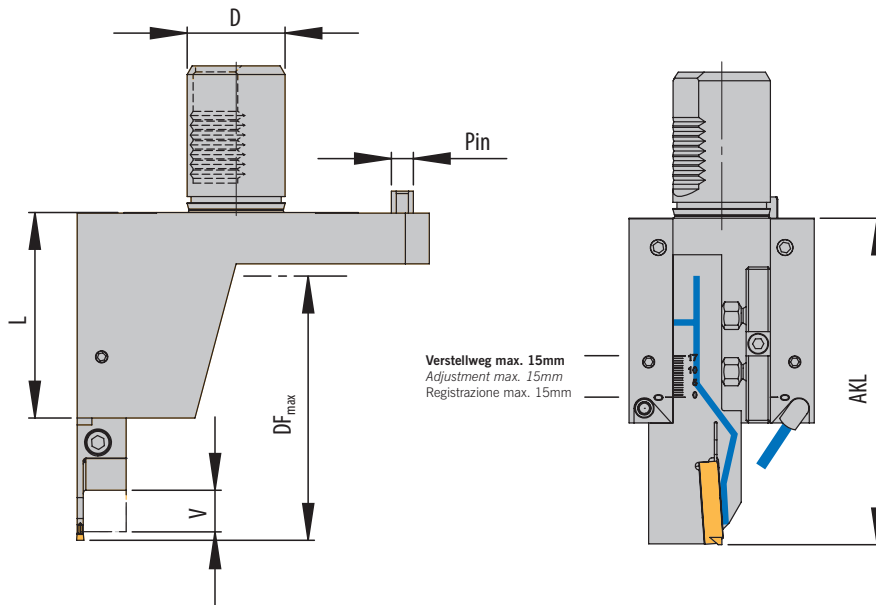

Linker Grundhalter und linker Monoblockhalter montiert
 Left basic holder and left monoblock holder shown
 Adattatore base sinistro e stelo monoblocco sinistra in figura

Grundhalter / Basic holder / Adattore

Bezeichnung Designation Articolo	D	L	Pin	F2	Monoblockhalter Monoblock holder Utensile monoblocco	PG 43
HMAZ-4020L-SQT10-IK	40	84	16	65,3	HSA/HSE 2020L-...ACS1-UN	●
HMAZ-4020L-ÜK-SQT10-IK	40	84	16	65,3	HSA/HSE 2020R-...ACS1-UN	●
HMAZ-4025L-SQT15-IK	40	120	20	78,3	HSA/HSE 2525L-...ACS1-UN	●
HMAZ-4025L-ÜK-SQT15-IK	40	120	20	78,3	HSA/HSE 2525R-...ACS1-UN	●

Monoblockhalter / Monoblock holder / Utensili monoblocco

DF_{max} = Maximaler Futterdurchmesser und AKL = Auskräglänge bei Monoblockhalter HSA/HSE / DF_{max} = maximum chuck diameter and AKL = Overhang length with Monoblock holder HSA/HSE / DF_{max} = Diametro max mandrino e AKL = Lunghezza totale con Utensili monoblocco HSA/HSE

Bezeichnung Designation Articolo	HMAZ-4020...			HMAZ-4025...		
	AKL	V*	$DF_{max}^{1)}$	AKL	V*	$DF_{max}^{2)}$
HSE...SE24..	108,5	17	170	144,0	22	220
HSE...SE24..	117,5	17	185	151,0	22	235
HSA...SA24...44-ACS1-UN	118,0	17	190	151,5	22	235
HSA...SA35...52-ACS1-UN	128,0	17	210	164,0	22	260
HSA...SA35...65-ACS1-UN	134,0	17	220	170,0	22	275

Hinweis: Passende Monoblockhalter finden Sie im Kapitel SA (Seite 56 bis 78) und SE (Seite 160 bis 174)

Remark: For Monoblock holder to suit please see chapter SA (Page 56 to 78) and SE (Page 160 to 174)

Nota: Per I moduli abbinabili vedere pagine da 56 a 78 e pagine da 160 a 174



Ersatzteile / Spare Parts / Ricambi

Trägerwerkzeug Holder Utensile	Schraube für Modul Screw for module Vite per modulo	Kühlmitteldüse Coolant jet Ugello refrigerante	Verschluss-Stift Locking pin Spina bloccaggio
HMAZ-4020L-SQT10-IK	G111	KMD 0820-4BJ	ZS0820G
HMAZ-4020L-ÜK-SQT10-IK	G111	KMD 0820-4BJ	ZS0820G
HMAZ-4025L-SQT15-IK	G104	KMD 0820-4BJ	ZS0820G
HMAZ-4025L-ÜK-SQT15-IK	G104	KMD 0820-4BJ	ZS0820G

Ersatzteile / Spare Parts / Ricambi

Monoblockhalter Monoblock holder Utensili monoblocco	Schraube Screw Vite	Schlüssel Key Chiave
HSA/HSE 2020.. - HSA/HSE 2525.. -SA35...52-ACS1-UN	DIN912 M6X20-12.9	KP 1321
HSA/HSE 2020.. - HSA/HSE 2525...SA24...44-ACS1-UN	DIN912 M5X16-12.9	KP 5421
HSA/HSE 2020.. - HSA/HSE 2525...SA35...65-ACS1-UN	DIN912 M6X20-12.9	KP 5421

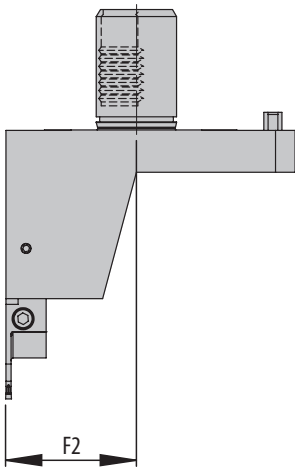
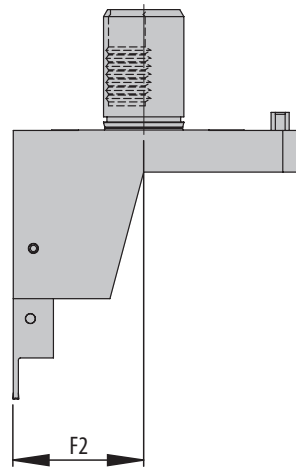
Einbaumöglichkeiten / Assembly options / Combinazioni di montaggio

Linker Halter Left-hand holder Adattatore sinistro	
HMAZ-4020L-SQT10-IK	HMAZ-4020L-ÜL-SQT10-IK
HMAZ-4025L-SQT15-IK	HMAZ-4025L-ÜK-SQT15-IK
	
Linker Monoblockhalter montiert Left Monoblock holder shown Utensili monoblocco sinistro in figura	Linker Monoblockhalter montiert Left Monoblock holder shown Utensili monoblocco sinistro in figura
	
Einbaulage normal Normal assembly Montaggio normale	Einbaulage Überkopf Upside down assembly Montaggio invertito

**Hinweis: Sonderabmessungen und Abstechhalter für andere Maschinenhersteller auf Anfrage erhältlich.
 Ein Anfrageblatt hierzu finden Sie auf Seite 578 oder im Internet unter: www.arno.de/service/downloads**

Remark: Custom made part-off holders for other machine manufacturers are available on request.
 Please complete enquiry sheet on page 578 or download this from www.arno.de/service/downloads

Nota: Adattatori speciali di differenti dimensioni e caratteristiche disponibili a richiesta.
 Vedere modulo richiesta a Pagina 578 o download del modulo da: www.arno.de/service/downloads

HMD - mit Innenkühlung

HMD - with internal coolant

HMD - con refrigerazione interna

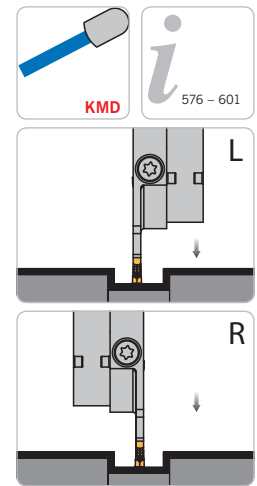
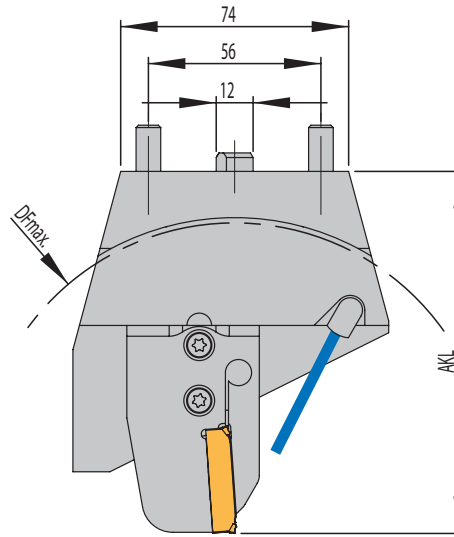
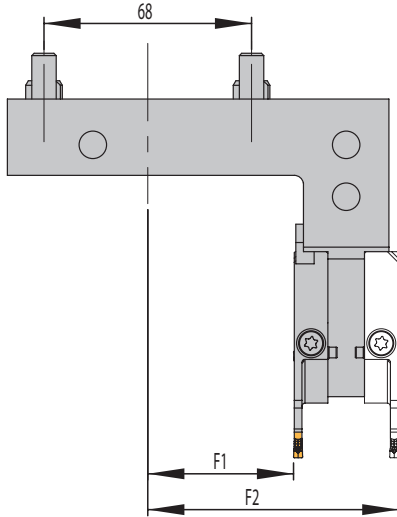

Linkes Modul montiert
 Rechtes Modul alternativ
 Left module shown
 Right module alternative
 Modulo sinistro in figura
 Modulo destro alternativa

Grundhalter / Basic holder / Adattore

Bezeichnung Designation Articolo	F1	F2	Modul Module Modulo	PG 43
HMD-BMT-SD	47,8	82,3	MSA-...-...	●

Modul / Module / Modulo

DF_{max} = Maximaler Futterdurchmesser und AKL = Auskräglänge bei Modul MSA-... / **DF_{max} = maximum chuck diameter and AKL = Overhang length with modules MSA-...** / **DF_{max} = Diametro max mandrino e AKL = Lunghezza totale con modulo MSA-...**

Bezeichnung Designation Articolo	HMD-BMT...	
	AKL	DF _{max}
MSA-...-32	102,0	165
MSA-...-44	107,0	175
MSA-...-52	117,5	195
MSA-...-65	117,5	195
MSA-...-80	125,0	210
MSA-...-105	138,0	235
MSA-...-125	148,0	250
MSA-...-140	155,5	265

Hinweis: Passende Module finden Sie im Kapitel SA (Seite 114 bis 128)

Remark: For modules to suit please see chapter SA (Page 114 to 128)

Nota: Per i moduli abbinabili vedere pagine da 114 a 128

Ersatzteile / Spare Parts / Ricambi





Trägerwerkzeug Holder Utensile	Schraube für Modul Screw for module Vite per modulo	Schlüssel Key Chiave	Kühlmitteldüse Coolant jet Ugello refrigerante
HMD-BMT-SD	AS 0070	T5220-IP	KMD 0825-3E

Ersatzteile / Spare Parts / Ricambi

Modul Module Modulo	Schraube für Modul Screw for module Vite per modulo	Schlüssel Key Chiave
MSA-...-	SA5T	T5220-IP



Einbaumöglichkeiten / Assembly options / Combinazioni di montaggio

Linkes Modul montiert <i>Left module shown</i> Modulo sinistro in figura	Rechtes Modul montiert <i>Right module shown</i> Modulo destro in figura
	
Einbaulage normal <i>Normal assembly</i> Montaggio normale	Einbaulage normal <i>Normal assembly</i> Montaggio normale
	
Einbaulage Überkopf <i>Upside down assembly</i> Montaggio invertito	Einbaulage Überkopf <i>Upside down assembly</i> Montaggio invertito

Hinweis: Mit einem Halter sind alle abgebildeten Varianten montierbar.

Remark: All shown options are available with only one holder.

Nota: E' sufficiente un solo corpo base per comporre tutte le combinazioni raffigurate.

Hinweis: Sonderabmessungen und Abstechhalter für andere Maschinenhersteller auf Anfrage erhältlich. Ein Anfrageblatt hierzu finden Sie auf Seite 578 oder im Internet unter: www.arno.de/service/downloads

Remark: Custom made part-off holders for other machine manufacturers are available on request.

Please complete enquiry sheet on page 578 or download this from www.arno.de/service/downloads

Nota: Adattatori speciali di differenti dimensioni e caratteristiche disponibili a richiesta.

Vedere modulo richiesta a Pagina 578 o download del modulo da: www.arno.de/service/downloads

HMD / HMSA - mit Innenkühlung und ACS

HMD / HMSA - with internal coolant and ACS

HMD / HMSA - con refrigerazione interna e ACS

Grundhalter - Module beidseitig montierbar / Basic holders - modules can be mounted on both sides / Corpo utensili

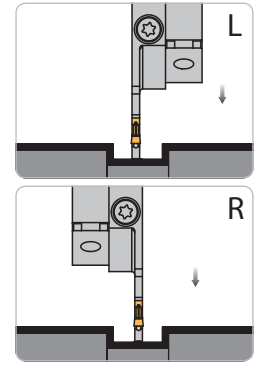
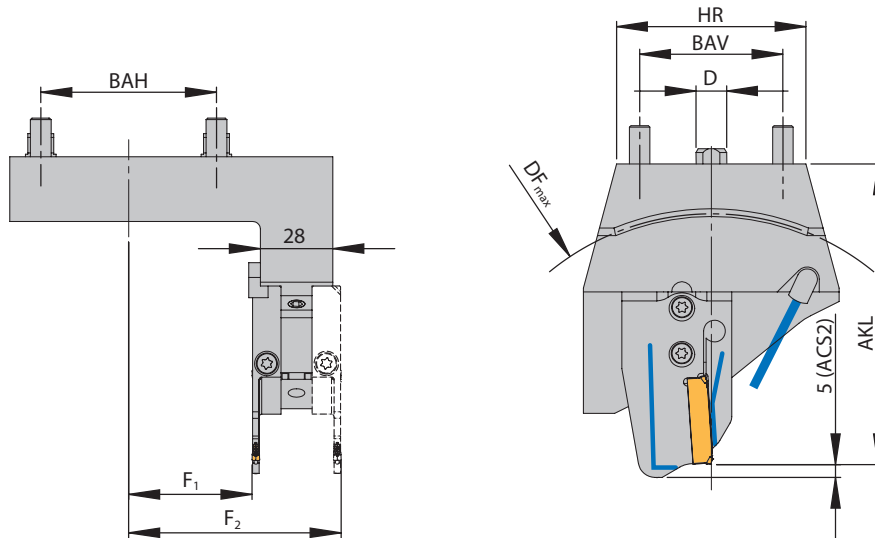

Rechter Halter und linkes Modul montiert
 Rechtes Modul alternativ
 Right holder and left module shown
 Right module alternative
 Adattatore destro e modulo sinistro in figura
 Modulo destro alternativa

Grundhalter / Basic holder / Adattore

Bezeichnung Designation Articolo	BAH	BAV	HR	D	F1	F2	Modul Module Modulo	PG 43
HMD-BMT-SDR-ACS	56	52	74	12	47,8	82,3	MSA-...-ACS.	●
HMSA-68-56-R-ACS	68	56	74	12	47,8	82,3	MSA-...-ACS.	●

Modul / Module / Modulo

DF_{max} = Maximaler Futterdurchmesser und AKL = Ausraglänge bei Modul MSA-... / DF_{max} = maximum chuck diameter and AKL = Overhang length with modules MSA-... / DF_{max} = Diametro max mandrino e AKL = Lunghezza totale con modulo MSA-...

Bezeichnung Designation Articolo	HMSA / HMD...	
	AKL	DF _{max}
MSA-...-32-ACS.	102,0	165
MSA-...-44-ACS.	107,0	175
MSA-...-52-ACS.	117,5	195
MSA-...-65-ACS.	117,5	195
MSA-...-69-ACS.	119,5	200
MSA-...-80-ACS.	125,0	210
MSA-...-90-ACS.	130,0	220
MSA-...-105-ACS.	138,0	230

Hinweis: Passende Module finden Sie im Kapitel SA (Seite 114 bis 128)

Remark: For modules to suit please see chapter SA (Page 114 to 128)

Nota: Per i moduli abbinabili vedere pagine da 114 a 128

Ersatzteile / Spare Parts / Ricambi





Trägerwerkzeug Holder Utensile	Schraube für Modul Screw for module Vite per modulo	Schlüssel Key Chiave	O-Ring O-ring O-Ring	Kühlmitteldüse Coolant jet Ugello refrigerante	Verschluss-Stift Locking pin Spina bloccaggio
HMD-BMT-SDR-ACS	AS 0070	T5220-IP	OR 14X1,5P	KMD 0825-3E	ZS0818
HMSA-68-56-R-ACS	AS 0070	T5220-IP	OR 14X1,5P	KMD 0825-3E	ZS0818

Ersatzteile / Spare Parts / Ricambi

Modul Module Modulo	Schraube für Modul Screw for module Vite per modulo	Schlüssel Key Chiave
MSA-...-	SA5T	T5220-IP



Einbaumöglichkeiten / Assembly options / Combinazioni di montaggio

<p>Linkes Modul montiert <i>Left module shown</i> Modulo sinistro in figura</p>	<p>Rechtes Modul montiert <i>Right module shown</i> Modulo destro in figura</p>
	
<p>Einbaulage normal <i>Normal assembly</i> Montaggio normale</p>	<p>Einbaulage normal <i>Normal assembly</i> Montaggio normale</p>
	
<p>Einbaulage Überkopf <i>Upside down assembly</i> Montaggio invertito</p>	<p>Einbaulage Überkopf <i>Upside down assembly</i> Montaggio invertito</p>

Hinweis: Mit einem Halter sind alle abgebildeten Varianten montierbar.

Remark: All shown options are available with only one holder.

Nota: E' sufficiente un solo corpo base per comporre tutte le combinazioni raffigurate.

Hinweis: Sonderabmessungen und Abstechhalter für andere Maschinenhersteller auf Anfrage erhältlich. Ein Anfrageblatt hierzu finden Sie auf Seite 578 oder im Internet unter: www.arno.de/service/downloads

Remark: Custom made part-off holders for other machine manufacturers are available on request. Please complete enquiry sheet on page 578 or download this from www.arno.de/service/downloads

Nota: Adattatori speciali di differenti dimensioni e caratteristiche disponibili a richiesta.

Vedere modulo richiesta a Pagina 578 o download del modulo da: www.arno.de/service/downloads

HMSA - mit ACS / HMSA - with ACS / HMSA - con ACS

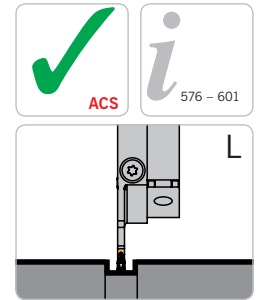
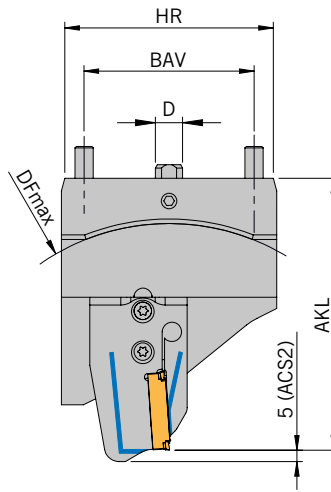
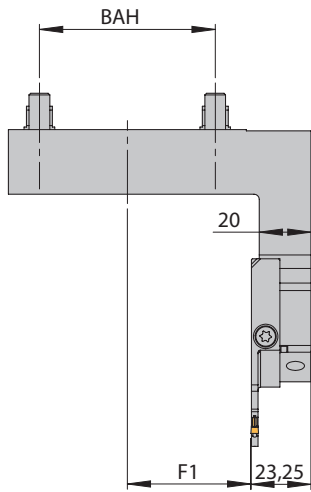

Rechter Halter und
linkes Modul montiert
Right holder and left module shown
Adattatore destro e
modulo sinistro in figura



Grundhalter / Basic holder / Adattore

Bezeichnung Designation Articolo	BAH	BAV	HR	D	F1	Modul Module Modulo	PG 43
HMSA-60-75-R-MSA-SL-ACS	60	75	92	12	47,8	MSA-SL-...-ACS.	●

Modul / Module / Modulo

DF_{max} = Maximaler Futterdurchmesser und **AKL** = Ausraglänge bei Modul MSA-... / **DF_{max}** = maximum chuck diameter and **AKL** = Overhang length with modules MSA-... / **DF_{max}** = Diametro max mandrino e **AKL** = Lunghezza totale con modulo MSA-...

Bezeichnung Designation Articolo	HMSA...	
	AKL	DF _{max}
MSA-...-32-ACS.	104,5	165
MSA-...-44-ACS.	109,5	175
MSA-...-52-ACS.	120,0	200
MSA-...-65-ACS.	120,0	200
MSA-...-69-ACS.	122,0	200
MSA-...-80-ACS.	127,5	210
MSA-...-90-ACS.	132,5	220
MSA-...-105-ACS.	140,5	235

Hinweis: Passende Module finden Sie im Kapitel SA (Seite 114 bis 128)

Remark: For modules to suit please see chapter SA (Page 114 to 128)

Nota: Per i moduli abbinabili vedere pagine da 114 a 128

Ersatzteile / Spare Parts / Ricambi

Trägerwerkzeug Holder Utensile	Schraube für Modul Screw for module Vite per modulo	Schlüssel Key Chiave	O-Ring O-ring O-Ring
HMSA-60-75-R-MSA-SL-ACS	AS 0070	T5220-IP	OR 14X1,5P

Ersatzteile / Spare Parts / Ricambi

Modul Module Modulo	Schraube für Modul Screw for module Vite per modulo	Schlüssel Key Chiave
MSA-...-	SA5T	T5220-IP

Einbaumöglichkeiten / Assembly options / Combinazioni di montaggio



Hinweis: Sonderabmessungen und Abstechhalter für andere Maschinenhersteller auf Anfrage erhältlich. Ein Anfrageblatt hierzu finden Sie auf Seite 578 oder im Internet unter: www.arno.de/service/downloads

Remark: Custom made part-off holders for other machine manufacturers are available on request. Please complete enquiry sheet on page 578 or download this from www.arno.de/service/downloads

Nota: Adattatori speciali di differenti dimensioni e caratteristiche disponibili a richiesta. Vedere modulo richiesta a Pagina 578 o download del modulo da: www.arno.de/service/downloads

HMSA - mit Innenkühlung und ACS / HMSA - with internal coolant and ACS / HMSA - con refrigerazione interna e ACS

Halter mit mehr Platz beim Abstechen an der Gegenspindel / Holder with more space for parting on the counter spindle / Adattore con più spazio al contromandrino per la troncatura

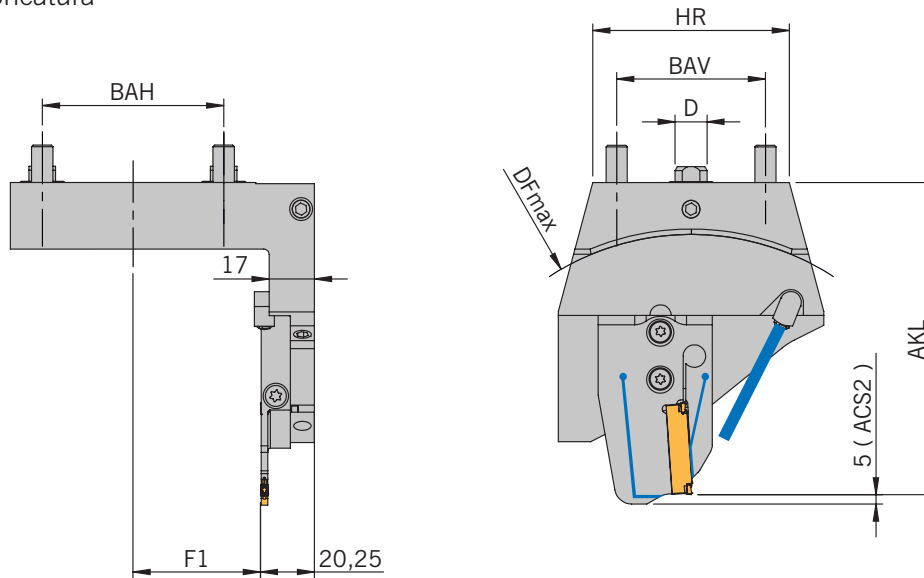
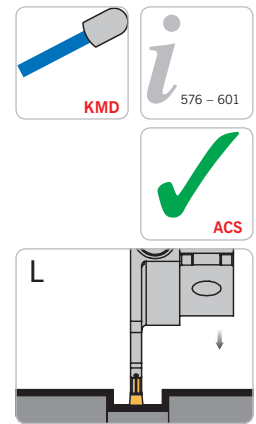

Rechter Halter und linkes Modul montiert
Right holder and left module shown
Adattatore destro e modulo sinistro in figura

Grundhalter / Basic holder / Adattore

Bezeichnung Designation Articolo	BAH	BAV	HR	D	F1	Modul Module Modulo	PG 43
HMSA-68-56-R-MSA-SL-ACS-S01	68	56	74	12	47,8	MSA-SL-...-ACS.	●

Modul / Module / Modulo

DF_{max} = Maximaler Futterdurchmesser und AKL = Ausraglänge bei Modul MSA-... / DF_{max} = maximum chuck diameter and AKL = Overhang length with modules MSA-... / DF_{max} = Diametro max mandrino e AKL = Lunghezza totale con modulo MSA-...

Bezeichnung Designation Articolo	HMSA...	
	AKL	DF_{max}
MSA-...-32-ACS.	102,0	165
MSA-...-44-ACS.	107,0	175
MSA-...-52-ACS.	117,5	195
MSA-...-65-ACS.	117,5	195
MSA-...-69-ACS.	119,5	200
MSA-...-80-ACS.	125,0	210
MSA-...-90-ACS.	130,0	215
MSA-...-105-ACS.	138,0	230

Hinweis: Passende Module finden Sie im Kapitel SA (Seite 114 bis 128)

Remark: For modules to suit please see chapter SA (Page 114 to 128)

Nota: Per I moduli abbinabili vedere pagine da 114 a 128

Ersatzteile / Spare Parts / Ricambi

Trägerwerkzeug Holder Utensile	Schraube für Modul Screw for module Vite per modulo	Schlüssel Key Chiave	O-Ring O-ring O-Ring	Kühlmitteldüse Coolant jet Ugello refrigerante
HMSA-68-56-R-MSA-SL-ACS-S01	AS 0070	T5220-IP	OR 14X1,5P	KMD 0820-4BJ

Ersatzteile / Spare Parts / Ricambi

Modul Module Modulo	Schraube für Modul Screw for module Vite per modulo	Schlüssel Key Chiave
MSA-...-	SA5T	T5220-IP

Einbaumöglichkeiten / Assembly options / Combinazioni di montaggio

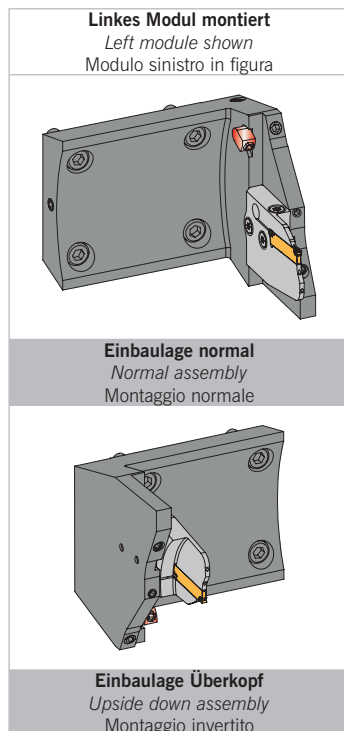

Hinweis: Sonderabmessungen und Abstechhalter für andere Maschinenhersteller auf Anfrage erhältlich. Ein Anfrageblatt hierzu finden Sie auf Seite 578 oder im Internet unter: www.arno.de/service/downloads

Remark: Custom made part-off holders for other machine manufacturers are available on request. Please complete enquiry sheet on page 578 or download this from www.arno.de/service/downloads

Nota: Adattatori speciali di differenti dimensioni e caratteristiche disponibili a richiesta. Vedere modulo richiesta a Pagina 578 o download del modulo da: www.arno.de/service/downloads

HMSA - mit ACS / HMSA - with ACS / HMSA - con ACS

Halter mit mehr Platz beim Abstechen an der Gegenspindel / Holder with more space for parting on the counter spindle / Adattore con più spazio al contromandrino per la troncatura

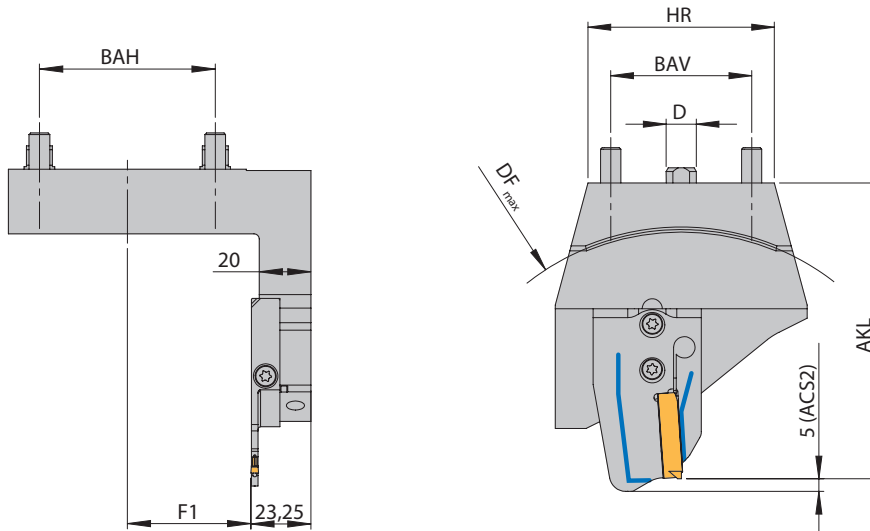
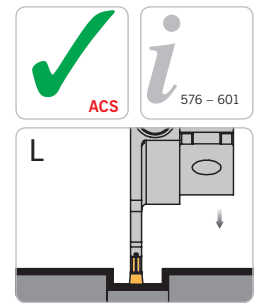

Rechter Halter und linkes Modul montiert
 Right holder and left module shown
 Adattore destro e modulo sinistro in figura



Grundhalter / Basic holder / Adattore

Bezeichnung Designation Articolo	BAH	BAV	HR	D	F1	Modul Module Modulo	PG 43
HMSA-68-56-R-MSA-SL-ACS	68	56	74	12	47,8	MSA-SL-...-ACS.	●

Modul / Module / Modulo

DF_{max} = Maximaler Futterdurchmesser und AKL = Auskräglänge bei Modul MSA-... / DF_{max} = maximum chuck diameter and AKL = Overhang length with modules MSA-... / DF_{max} = Diametro max mandrino e AKL = Lunghezza totale con modulo MSA-...

Bezeichnung Designation Articolo	HMSA...	
	AKL	DF_{max}
MSA-...-32-ACS.	102,0	165
MSA-...-44-ACS.	107,0	175
MSA-...-52-ACS.	117,5	195
MSA-...-65-ACS.	117,5	195
MSA-...-69-ACS.	119,5	200
MSA-...-80-ACS.	125,0	210
MSA-...-90-ACS.	130,0	220
MSA-...-105-ACS.	138,0	230

Hinweis: Passende Module finden Sie im Kapitel SA (Seite 114 bis 128)

Remark: For modules to suit please see chapter SA (Page 114 to 128)

Nota: Per i moduli abbinabili vedere pagine da 114 a 128

Ersatzteile / Spare Parts / Ricambi

Trägerwerkzeug Holder Utensile	Schraube für Modul Screw for module Vite per modulo	Schlüssel Key Chiave	O-Ring O-ring O-Ring
HMSA-68-56-R-MSA-SL-ACS	AS 0070	T5220-IP	OR 14X1,5P

Ersatzteile / Spare Parts / Ricambi

Modul Module Modulo	Schraube für Modul Screw for module Vite per modulo	Schlüssel Key Chiave
MSA-...-	SA5T	T5220-IP

Einbaumöglichkeiten / Assembly options / Combinazioni di montaggio



Hinweis: Sonderabmessungen und Abstechhalter für andere Maschinenhersteller auf Anfrage erhältlich. Ein Anfrageblatt hierzu finden Sie auf Seite 578 oder im Internet unter: www.arno.de/service/downloads

Remark: Custom made part-off holders for other machine manufacturers are available on request. Please complete enquiry sheet on page 578 or download this from www.arno.de/service/downloads

Nota: Adattatori speciali di differenti dimensioni e caratteristiche disponibili a richiesta. Vedere modulo richiesta a Pagina 578 o download del modulo da: www.arno.de/service/downloads

NZ, NL - mit Innenkühlung und ACS
 NZ, NL - with internal coolant and ACS
 NZ, NL - con refrigerazione interna e ACS

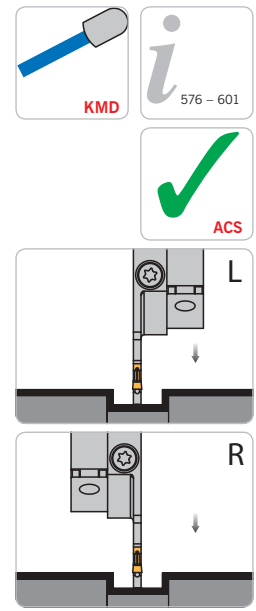
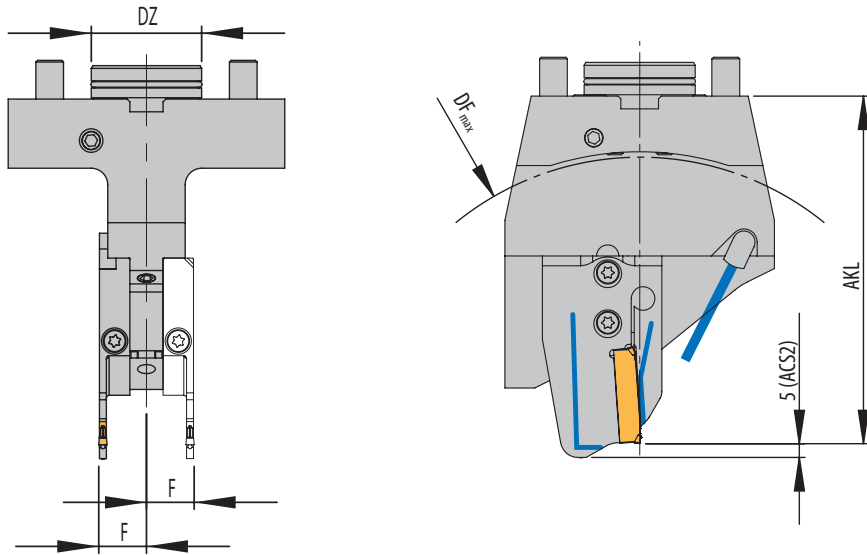

Linkes Modul montiert
 Halter höhenstellbar
 Rechtes Modul alternativ
 Left module shown
 Height adjustable holder
 Right module alternative
 Modulo sinistro in figura
 Adattatore registrabile in altezza
 Modulo destro alternativa

Grundhalter / Basic holder / Adattore

Bezeichnung Designation Articolo	DZ	F	Modul Module Modulo	PG 43
HDM-NZ-BMT-SDS-ACS	40	17.3	MSA-...-ACS.	●
HDM-NL-BMT-SDS-ACS	60	17.3	MSA-...-ACS.	●

Modul / Module / Modulo

DF_{max} = Maximaler Futterdurchmesser und AKL = Ausraglänge bei Modul MSA-... / DF_{max} = maximum chuck diameter and AKL = Overhang length with modules MSA-... / DF_{max} = Diametro max mandrino e AKL = Lunghezza totale con modulo MSA-...

Bezeichnung Designation Articolo	HDM-NZ...		HDM-NL...	
	AKL	DF_{max}	AKL	DF_{max}
MSA-...-32-ACS.	109,5	165	140,5	235
MSA-...-44-ACS.	114,5	175	145,5	245
MSA-...-52-ACS.	125,0	200	156,0	265
MSA-...-65-ACS.	125,0	200	156,0	265
MSA-...-69-ACS.	127,0	210	158,0	270
MSA-...-80-ACS.	132,5	210	163,5	280
MSA-...-90-ACS.	137,5	220	168,5	290
MSA-...-105-ACS.	145,5	235	176,5	305

Hinweis: Passende Module finden Sie im Kapitel SA (Seite 114 bis 128)

Remark: For modules to suit please see chapter SA (Page 114 to 128)

Nota: Per i moduli abbinabili vedere pagine da 114 a 128





Ersatzteile / Spare Parts / Ricambi

Trägerwerkzeug Holder Utensile	Schraube für Modul Screw for module Vite per modulo	Schlüssel Key Chiave	O-Ring O-ring O-Ring	Kühlmitteldüse Coolant jet Ugello refrigerante
HDM-NZ-...-ACS	AS 0070	T5220-IP	OR 36 x 2 P	KMD 0825-3E
HDM-NL-...-ACS	AS 0070	T5220-IP	OR 54 x 3 P	KMD 0825-3E

Ersatzteile / Spare Parts / Ricambi

Modul Module Modulo	Schraube für Modul Screw for module Vite per modulo	Schlüssel Key Chiave
MSA-...	SA5T	T5220-IP

Einbaumöglichkeiten / Assembly options / Combinazioni di montaggio

<p>Linkes Modul montiert <i>Left module shown</i> Modulo sinistro in figura</p>	<p>Rechtes Modul montiert <i>Right module shown</i> Modulo destro in figura</p>
	
<p>Einbaulage normal <i>Normal assembly</i> Montaggio normale</p>	<p>Einbaulage normal <i>Normal assembly</i> Montaggio normale</p>
	
<p>Einbaulage Überkopf <i>Upside down assembly</i> Montaggio invertito</p>	<p>Einbaulage Überkopf <i>Upside down assembly</i> Montaggio invertito</p>

**Hinweis: Sonderabmessungen und Abstechhalter für andere Maschinenhersteller auf Anfrage erhältlich.
 Ein Anfrageblatt hierzu finden Sie auf Seite 578 oder im Internet unter: www.arno.de/service/downloads**

*Remark: Custom made part-off holders for other machine manufacturers are available on request.
 Please complete enquiry sheet on page 578 or download this from www.arno.de/service/downloads*

*Nota: Adattatori speciali di differenti dimensioni e caratteristiche disponibili a richiesta.
 Vedere modulo richiesta a Pagina 578 o download del modulo da: www.arno.de/service/downloads*

--> Anwendungshinweise finden Sie auf S. 592/593
 --> For application reference please see page 592/593
 --> Per suggerimenti tecnici vedere pagina 592/593

NZ, NL - mit Innenkühlung und ACS
 NZ, NL - with internal coolant and ACS
 NZ, NL - con refrigerazione interna e ACS

Grundhalter - Module beidseitig montierbar / Basic holders - modules can be mounted on both sides / Corpo utensili

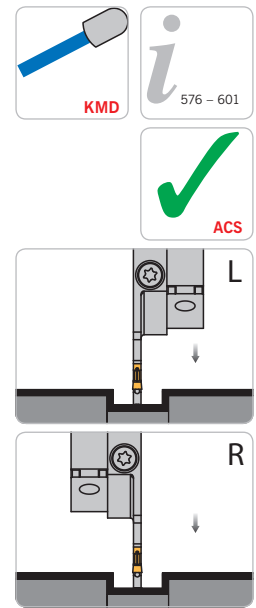
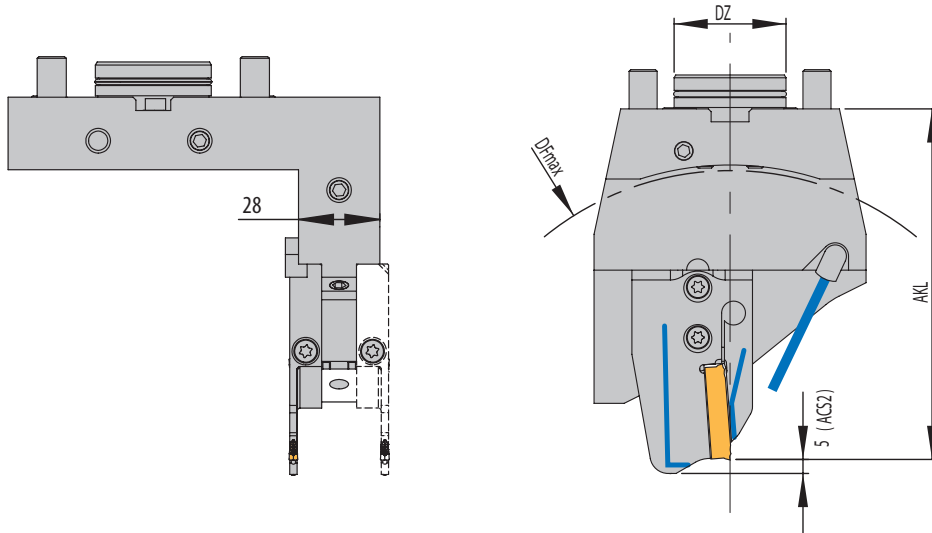

Rechter Halter und linkes Modul montiert
 Halter höhenstellbar
 Rechtes Modul alternativ
 Right holder and left module shown
 Height adjustable holder
 Right module alternative
 Adattatore destro e modulo sinistro in figura
 Adattatore registrabile in altezza
 Modulo destro alternativa

Grundhalter / Basic holder / Adattore

Bezeichnung Designation Articolo	DZ	F1	F2	Modul Module Modulo	PG 43
HDM-NZ-BMT-SDL-ACS	40	46,8	81,3	MSA-...-ACS.	●
HDM-NZ-BMT-SDR-ACS	40	46,8	81,3	MSA-...-ACS.	●
HDM-NL-BMT-SDL-ACS	60	60,8	95,3	MSA-...-ACS.	●
HDM-NL-BMT-SDR-ACS	60	60,8	95,3	MSA-...-ACS.	●

Modul / Module / Modulo

DF_{max} = Maximaler Futterdurchmesser und AKL = Auskräglänge bei Modul MSA-... / DF_{max} = maximum chuck diameter and AKL = Overhang length with modules MSA-... / DF_{max} = Diametro max mandrino e AKL = Lunghezza totale con modulo MSA-...

Bezeichnung Designation Articolo	HDM-NZ...		HDM-NL...	
	AKL	DF_{max}	AKL	DF_{max}
MSA-...-32-ACS.	109,5	165	140,5	235
MSA-...-44-ACS.	114,5	175	145,5	245
MSA-...-52-ACS.	125,0	200	156,0	265
MSA-...-65-ACS.	125,0	200	156,0	265
MSA-...-69-ACS.	127,0	210	158,0	270
MSA-...-80-ACS.	132,5	210	163,5	280
MSA-...-90-ACS.	137,5	220	168,5	290
MSA-...-105-ACS.	145,5	235	176,5	305

Hinweis: Passende Module finden Sie im Kapitel SA (Seite 114 bis 128)

Remark: For modules to suit please see chapter SA (Page 114 to 128)

Nota: Per i moduli abbinabili vedere pagine da 114 a 128

Ersatzteile / Spare Parts / Ricambi

Trägerwerkzeug Holder Utensile	Schraube für Modul Screw for module Vite per modulo	Schlüssel Key Chiave	O-Ring O-ring O-Ring	Kühlmitteldüse Coolant jet Ugello refrigerante
HDM-NL-...-SDR/L-ACS	AS 0070	T5220-IP	OR 36 x 2 P	KMD 0825-3E
HDM-NZ-...-SDR/L-ACS	AS 0070	T5220-IP	OR 54 x 3 P	KMD 0825-3E

Ersatzteile / Spare Parts / Ricambi

Modul Module Modulo	Schraube für Modul Screw for module Vite per modulo	Schlüssel Key Chiave
MSA-...-	SA5T	T5220-IP

Einbaumöglichkeiten / Assembly options / Combinazioni di montaggio

Linker Halter Left-hand holder Adattatore sinistro		Rechter Halter Right-hand holder Adattatore destro	
HDM-NZ-BMT-SDL-ACS		HDM-NZ-BMT-SDR-ACS	
HDM-NL-BMT-SDL-ACS		HDM-NL-BMT-SDR-ACS	
Linkes Modul montiert Left module shown Modulo sinistro in figura	Rechtes Modul montiert Right module shown Modulo destro in figura	Linkes Modul montiert Left module shown Modulo sinistro in figura	Rechtes Modul montiert Right module shown Modulo destro in figura
Einbaulage normal Normal assembly Montaggio normale	Einbaulage normal Normal assembly Montaggio normale	Einbaulage normal Normal assembly Montaggio normale	Einbaulage normal Normal assembly Montaggio normale
Einbaulage Überkopf Upside down assembly Montaggio invertito	Einbaulage Überkopf Upside down assembly Montaggio invertito	Einbaulage Überkopf Upside down assembly Montaggio invertito	Einbaulage Überkopf Upside down assembly Montaggio invertito

Hinweis: Sonderabmessungen und Abstechhalter für andere Maschinenhersteller auf Anfrage erhältlich. Ein Anfrageblatt hierzu finden Sie auf Seite 578 oder im Internet unter: www.arno.de/service/downloads

Remark: Custom made part-off holders for other machine manufacturers are available on request. Please complete enquiry sheet on page 578 or download this from www.arno.de/service/downloads

Nota: Adattatori speciali di differenti dimensioni e caratteristiche disponibili a richiesta. Vedere modulo richiesta a Pagina 578 o download del modulo da: www.arno.de/service/downloads

--> Anwendungshinweise finden Sie auf S. 592/593
 --> For application reference please see page 592/593
 --> Per suggerimenti tecnici vedere pagina 592/593

NZ - mit Innenkühlung und ACS
 NZ - with internal coolant and ACS
 NZ - con refrigerazione interna e ACS

Grundhalter - mit mehr Platz beim Abstechen an der Gegenspindel / Basic holders
 - with more space for parting on the counter spindle / Corpo utensili

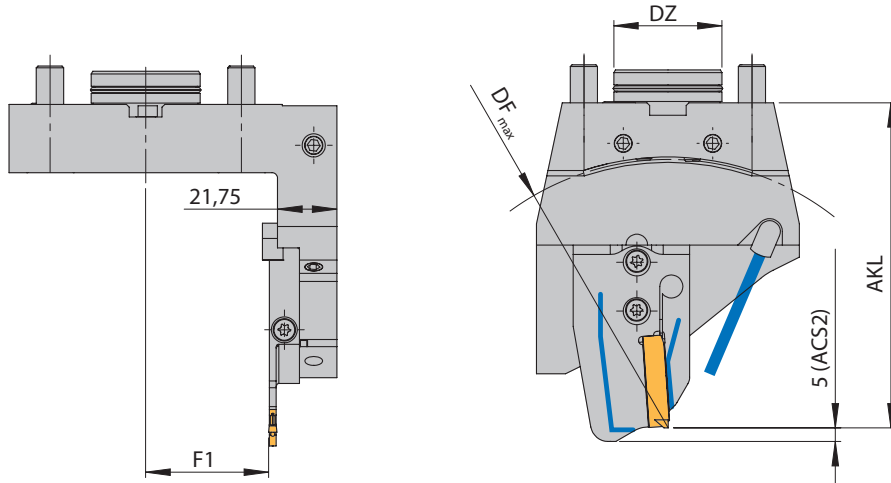
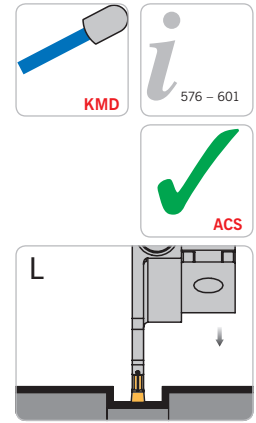

Rechter Halter und linkes Modul montiert
 Halter höhenstellbar
 Right holder and left module shown
 Height adjustable holder
 Adattatore destro e modulo sinistro in figura
 Adattatore registrabile in altezza



Grundhalter / Basic holder / Adattore

Bezeichnung Designation Articolo	DZ	F1	Modul Module Modulo	PG 43
HDM-NZ-BMT-R-MSA-SL-ACS	40	45	MSA-SL-...-ACS.	●

Modul / Module / Modulo

DF_{max} = Maximaler Futterdurchmesser und AKL = Auskraglänge bei Modul MSA-... / **DF_{max} = maximum chuck diameter and AKL = Overhang length with modules MSA-...** / **DF_{max} = Diametro max mandrino e AKL = Lunghezza totale con modulo MSA-...**

Bezeichnung Designation Articolo	HDM-NZ...	
	AKL	DF _{max}
MSA-...-32-ACS.	104,5	155
MSA-...-44-ACS.	109,5	165
MSA-...-52-ACS.	120,0	190
MSA-...-65-ACS.	120,0	190
MSA-...-69-ACS.	122,0	200
MSA-...-80-ACS.	127,5	205
MSA-...-90-ACS.	132,5	215
MSA-...-105-ACS.	140,5	225

Hinweis: Passende Module finden Sie im Kapitel SA (Seite 114 bis 128)
 Remark: For modules to suit please see chapter SA (Page 114 to 128)
 Nota: Per I moduli abbinabili vedere pagine da 114 a 128



Ersatzteile / Spare Parts / Ricambi

Trägerwerkzeug Holder Utensile	Schraube für Modul Screw for module Vite per modulo	Schlüssel Key Chiave	O-Ring O-ring O-Ring	Kühlmitteldüse Coolant jet Ugello refrigerante
HDM-NZ-...-ACS	AS 0070	T5220-IP	OR 36X2 P	KMD 0825-3E

Ersatzteile / Spare Parts / Ricambi

Modul Module Modulo	Schraube für Modul Screw for module Vite per modulo	Schlüssel Key Chiave
MSA-...-	SA5T	T5220-IP

Einbaumöglichkeiten / Assembly options / Combinazioni di montaggio



**Hinweis: Sonderabmessungen und Abstechhalter für andere Maschinenhersteller auf Anfrage erhältlich.
Ein Anfrageblatt hierzu finden Sie auf Seite 578 oder im Internet unter: www.arno.de/service/downloads**

*Remark: Custom made part-off holders for other machine manufacturers are available on request.
Please complete enquiry sheet on page 578 or download this from www.arno.de/service/downloads*

*Nota: Adattatori speciali di differenti dimensioni e caratteristiche disponibili a richiesta.
Vedere modulo richiesta a Pagina 578 o download del modulo da: www.arno.de/service/downloads*

--> **Anwendungshinweise finden Sie auf S. 592/593**
--> *For application reference please see page 592/593*
--> *Per suggerimenti tecnici vedere pagina 592/593*

HMU - mit Innenkühlung und ACS / HMU - with internal coolant and ACS / HMU - con refrigerazione interna e ACS

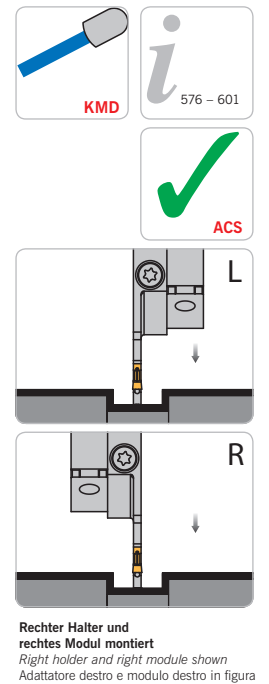
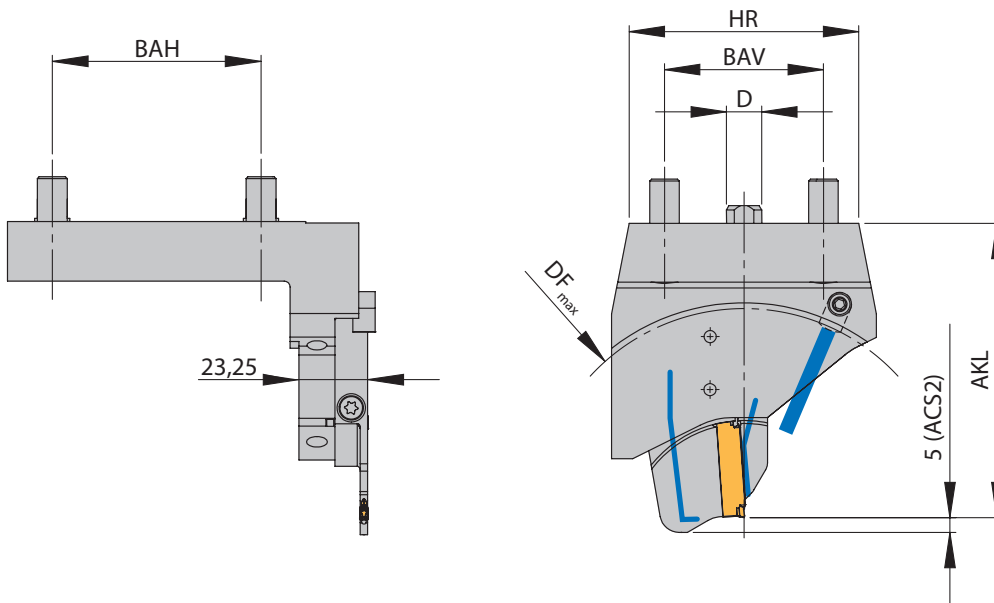

Grundhalter / Basic holder / Adattore

Bezeichnung Designation Articolo	BAH	BAV	HR	D	F2	Modul Module Modulo	PG 43
HMU-70-54-L/R-ACS	70	54	78	12	71	MSA-SL-...-ACS.	●

Modul / Module / Modulo

DF_{max} = Maximaler Futterdurchmesser und AKL = Ausraglänge bei Modul MSA-... / DF_{max} = maximum chuck diameter and AKL = Overhang length with modules MSA-... / DF_{max} = Diametro max mandrino e AKL = Lunghezza totale con modulo MSA-...

Bezeichnung Designation Articolo	HMU...	
	AKL	DF _{max}
MSA-...-32-ACS.	84,5	110
MSA-...-44-ACS.	89,5	120
MSA-...-52-ACS.	100,0	140
MSA-...-65-ACS.	100,0	140
MSA-...-69-ACS.	102,0	145
MSA-...-80-ACS.	107,5	155
MSA-...-90-ACS.	112,5	160
MSA-...-105-ACS.	120,5	175

Hinweis: Passende Module finden Sie im Kapitel SA (Seite 114 bis 128)
Remark: For modules to suit please see chapter SA (Page 114 to 128)
Nota: Per i moduli abbinabili vedere pagine da 114 a 128





Ersatzteile / Spare Parts / Ricambi

Trägerwerkzeug Holder Utensile	Schraube für Modul Screw for module Vite per modulo	Schlüssel Key Chiave	O-Ring O-ring O-Ring	Kühlmitteldüse Coolant jet Ugello refrigerante	Verschluss-Stift Locking pin Spina bloccaggio
HMU-70-54-.-ACS	AS 0070	T5220-IP	OR 14X1,5P	KMD 0825-3E	ZS0818

Ersatzteile / Spare Parts / Ricambi

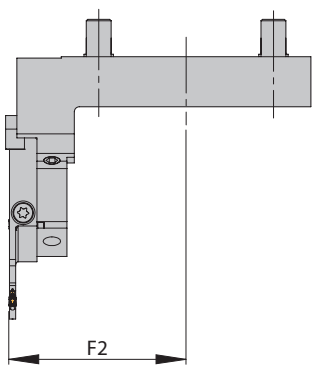
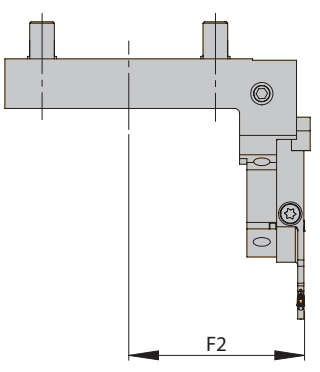
Modul Module Modulo	Schraube für Modul Screw for module Vite per modulo	Schlüssel Key Chiave
MSA-...-	SA5T	T5220-IP

Einbaumöglichkeiten / Assembly options / Combinazioni di montaggio

<p>Linker Halter Left-hand holder Adattatore sinistro</p> <p>HMU-70-54-L-ACS</p> 	<p>Rechter Halter Right-hand holder Adattatore destro</p> <p>HMU-70-54-R-ACS</p> 
<p>Linkes Modul montiert Left module shown Modulo sinistro in figura</p> 	<p>Rechtes Modul montiert Right module shown Modulo destro in figura</p> 
<p>Einbaulage normal Normal assembly Montaggio normale</p> 	<p>Einbaulage normal Normal assembly Montaggio normale</p> 
<p>Einbaulage Überkopf Upside down assembly Montaggio invertito</p>	<p>Einbaulage Überkopf Upside down assembly Montaggio invertito</p>

Hinweis: Sonderabmessungen und Abstechhalter für andere Maschinenhersteller auf Anfrage erhältlich. Ein Anfrageblatt hierzu finden Sie auf Seite 578 oder im Internet unter: www.arno.de/service/downloads

Remark: Custom made part-off holders for other machine manufacturers are available on request. Please complete enquiry sheet on page 578 or download this from www.arno.de/service/downloads

Nota: Adattatori speciali di differenti dimensioni e caratteristiche disponibili a richiesta. Vedere modulo richiesta a Pagina 578 o download del modulo da: www.arno.de/service/downloads

HMU - mit Innenkühlung und ACS / HMU - with internal coolant and ACS / HMU - con refrigerazione interna e ACS

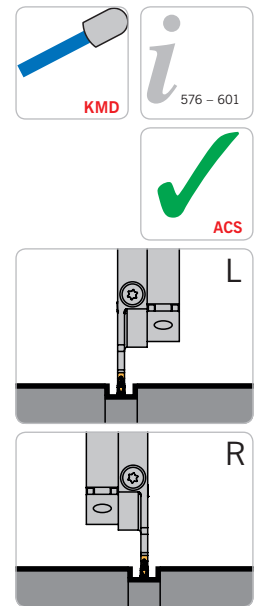
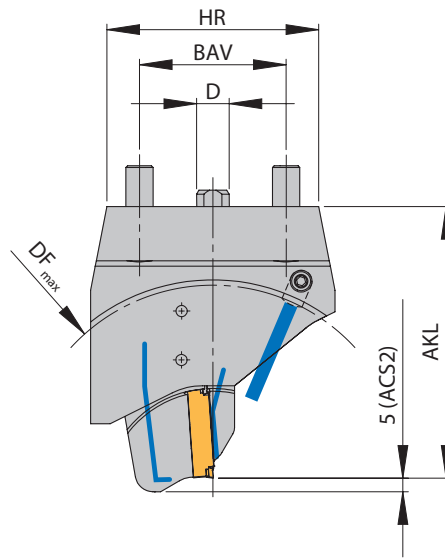
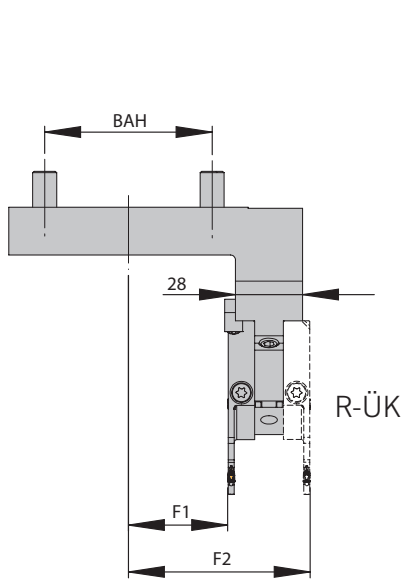

Rechter Halter und linkes Modul montiert
Rechtes Modul alternativ
Right holder and left module shown
Right module alternative
Adattatore destro e modulo sinistro in figura
Modulo destro alternativa



Grundhalter / Basic holder / Adattore

Bezeichnung Designation Articolo	BAH	BAV	HR	D	F1	F2	Modul Module Modulo	PG 43
HMU-70-54-122,5-R-ACS	70	54	78	12	41,5	76	MSA-...-ACS.	●

Modul / Module / Modulo

DF_{max} = Maximaler Futterdurchmesser und AKL = Auskraglänge bei Modul MSA-... / DF_{max} = maximum chuck diameter and AKL = Overhang length with modules MSA-... / DF_{max} = Diametro max mandrino e AKL = Lunghezza totale con modulo MSA-...

Bezeichnung Designation Articolo	HMU...	
	AKL	DF _{max}
MSA-...-32-ACS.	99,5	155
MSA-...-44-ACS.	104,5	165
MSA-...-52-ACS.	115,0	185
MSA-...-65-ACS.	115,0	185
MSA-...-69-ACS.	117,0	190
MSA-...-80-ACS.	122,5	200
MSA-...-90-ACS.	127,5	210
MSA-...-105-ACS.	135,5	225

Hinweis: Passende Module finden Sie im Kapitel SA (Seite 114 bis 128)

Remark: For modules to suit please see chapter SA (Page 114 to 128)

Nota: Per i moduli abbinabili vedere pagine da 114 a 128



Ersatzteile / Spare Parts / Ricambi

Trägerwerkzeug Holder Utensile	Schraube für Modul Screw for module Vite per modulo	Schlüssel Key Chiave	O-Ring O-ring O-Ring	Kühlmitteldüse Coolant jet Ugello refrigerante	Verschluss-Stift Locking pin Spina bloccaggio
HMU-70-54-122,5-R-ACS	AS 0070	T5220-IP	OR 14X1,5P	KMD 0825-3E	ZS0818

Ersatzteile / Spare Parts / Ricambi

Modul Module Modulo	Schraube für Modul Screw for module Vite per modulo	Schlüssel Key Chiave
MSA-...-	SA5T	T5220-IP

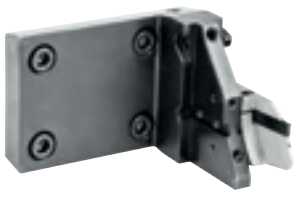
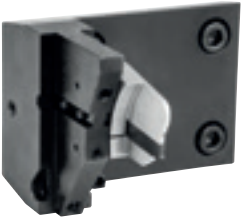
Einbaumöglichkeiten / Assembly options / Combinazioni di montaggio

<p>Linkes Modul montiert <i>Left module shown</i> Modulo sinistro in figura</p>	<p>Rechtes Modul montiert <i>Right module shown</i> Modulo destro in figura</p>
	
<p>Einbaulage normal <i>Normal assembly</i> Montaggio normale</p>	<p>Einbaulage normal <i>Normal assembly</i> Montaggio normale</p>
	
<p>Einbaulage Überkopf <i>Upside down assembly</i> Montaggio invertito</p>	<p>Einbaulage Überkopf <i>Upside down assembly</i> Montaggio invertito</p>

**Hinweis: Sonderabmessungen und Abstechhalter für andere Maschinenhersteller auf Anfrage erhältlich.
Ein Anfrageblatt hierzu finden Sie auf Seite 578 oder im Internet unter: www.arno.de/service/downloads**

*Remark: Custom made part-off holders for other machine manufacturers are available on request.
Please complete enquiry sheet on page 578 or download this from www.arno.de/service/downloads*

*Nota: Adattatori speciali di differenti dimensioni e caratteristiche disponibili a richiesta.
Vedere modulo richiesta a Pagina 578 o download del modulo da: www.arno.de/service/downloads*

WT100/WY100/NTY3/WT150 - mit Innenkühlung
 WT100/WY100/NTY3/WT150 - with internal coolant
 WT100/WY100/NTY3/WT150 - con refrigerazione interna

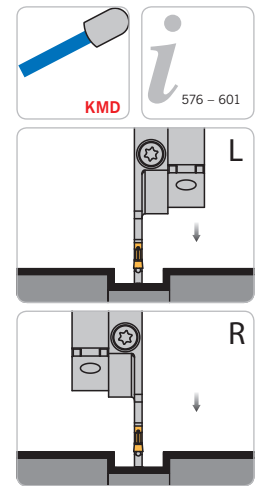
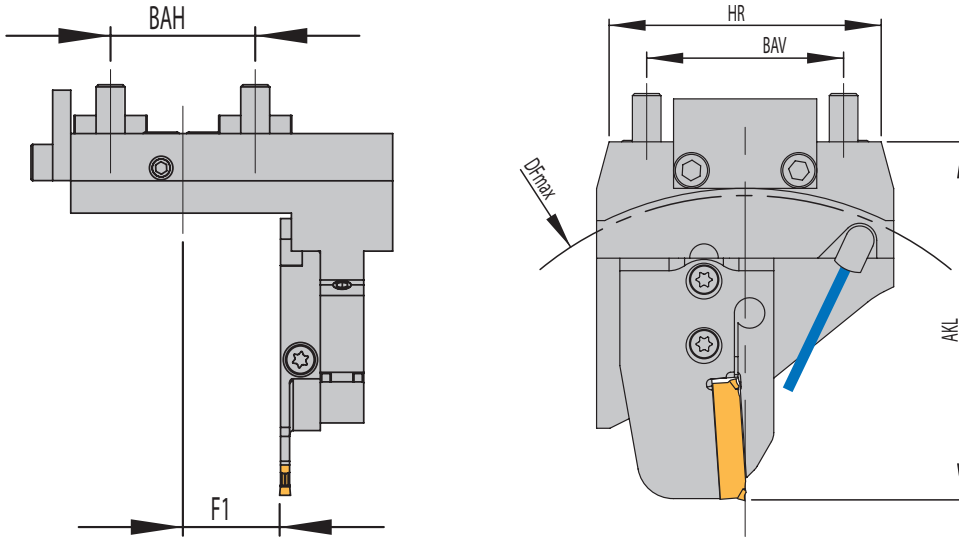

Rechter Halter und linkes Modul montiert
 Right holder and left module shown
 Adattatore destro e modulo sinistro in figura

Grundhalter / Basic holder / Adattore

Bezeichnung Designation Articolo	BAH	BAV	HR	F1	F2	Modul Module Modulo	PG 43
HNSA-RB62-L/R	40	55	76	26,8	61,3	MSA-...	●
HNSA-RB80-R	50	60	80	33,8	68,3	MSA-...	●

Modul / Module / Modulo

DF_{max} = Maximaler Futterdurchmesser und AKL = Auskraglänge bei Modul MSA-... / DF_{max} = maximum chuck diameter and AKL = Overhang length with modules MSA-... / DF_{max} = Diametro max mandrino e AKL = Lunghezza totale con modulo MSA-...

Bezeichnung Designation Articolo	HNSA-RB62...		HNSA-RB80...	
	AKL	DF _{max}	AKL	DF _{max}
MSA-...-32	84,5	135	87,0	140
MSA-...-44	89,5	145	92,0	150
MSA-...-52	100,0	165	102,5	170
MSA-...-65	100,0	165	102,5	170
MSA-...-80	107,5	180	110,0	185
MSA-...-105	120,5	205	123,0	210
MSA-...-125	130,5	225	133,0	230
MSA-...-140	138,0	240	140,5	245

Hinweis: Passende Module finden Sie im Kapitel SA (Seite 114 bis 128)

Remark: For modules to suit please see chapter SA (Page 114 to 128)

Nota: Per i moduli abbinabili vedere pagine da 114 a 128

Ersatzteile / Spare Parts / Ricambi

Trägerwerkzeug Holder Utensile	Schraube für Modul Screw for module Vite per modulo	Schlüssel Key Chiave	O-Ring O-ring O-Ring	Kühlmitteldüse Coolant jet Ugello refrigerante
HNSA-RB62-	AS 0070	T5220-IP	OR 8X1,5 P	KMD 0825-3E
HNSA-RB80-R	AS 0070	T5220-IP	OR 8X1,5 P	KMD 0825-3E

Ersatzteile / Spare Parts / Ricambi

Modul Module Modulo	Schraube für Modul Screw for module Vite per modulo	Schlüssel Key Chiave
MSA-...	SA5T	T5220-IP

Einbaumöglichkeiten / Assembly options / Combinazioni di montaggio

Linker Halter Left-hand holder Adattatore sinistro		Rechter Halter Right-hand holder Adattatore destro	
HNSA-RB62-L	HNSA-RB62-L	HNSA-RB62-R	HNSA-RB62-R
HNSA-RB80-L		HNSA-RB80-R	
Linkes Modul montiert Left module shown Modulo sinistro in figura	Rechtes Modul montiert Right module shown Modulo destro in figura	Linkes Modul montiert Left module shown Modulo sinistro in figura	Rechtes Modul montiert Right module shown Modulo destro in figura
Einbaulage normal Normal assembly Montaggio normale	Einbaulage normal Normal assembly Montaggio normale	Einbaulage normal Normal assembly Montaggio normale	Einbaulage normal Normal assembly Montaggio normale
Einbaulage Überkopf Upside down assembly Montaggio invertito	Einbaulage Überkopf Upside down assembly Montaggio invertito	Einbaulage Überkopf Upside down assembly Montaggio invertito	Einbaulage Überkopf Upside down assembly Montaggio invertito

Hinweis: Sonderabmessungen und Abstechhalter für andere Maschinenhersteller auf Anfrage erhältlich. Ein Anfrageblatt hierzu finden Sie auf Seite 578 oder im Internet unter: www.arno.de/service/downloads

Remark: Custom made part-off holders for other machine manufacturers are available on request. Please complete enquiry sheet on page 578 or download this from www.arno.de/service/downloads

Nota: Adattatori speciali di differenti dimensioni e caratteristiche disponibili a richiesta. Vedere modulo richiesta a Pagina 578 o download del modulo da: www.arno.de/service/downloads

RB62 / RB80 - mit Innenkühlung und ACS
 RB62 / RB80 - with internal coolant and ACS
 RB62 / RB80 - con refrigerazione interna e ACS

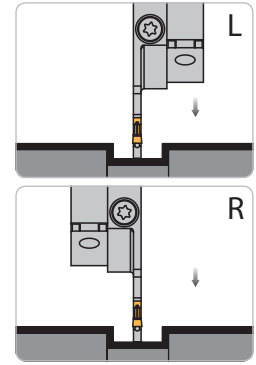
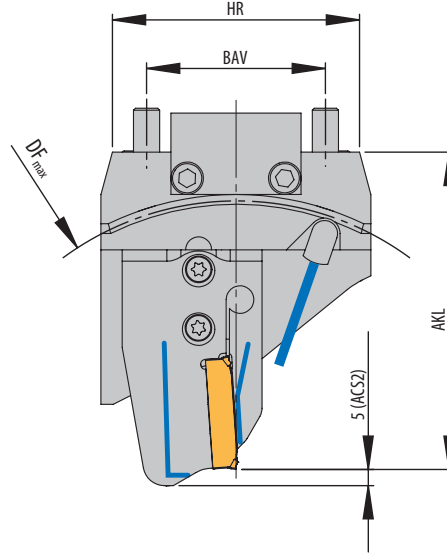
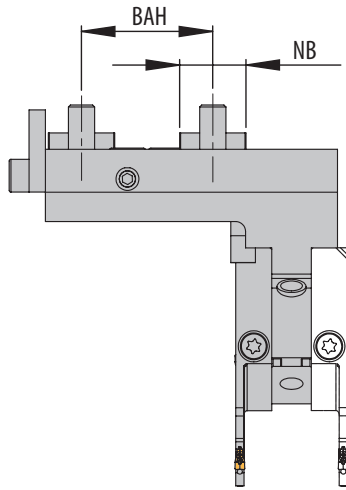

Rechter Halter und linkes Modul montiert
 Rechtes Modul alternativ
 Right holder and left module shown
 Right module alternative
 Adattatore destro e modulo sinistro in figura
 Modulo destro alternativa

NEU/NEW/NUOVO

Grundhalter / Basic holder / Adattore

Bezeichnung Designation Articolo	BAH	BAV	HR	NB	F1	F2	Modul Module Modulo	PG 43
HNSA-RB62-SDL/R-ACS	40	55	76	20	26,8	61,3	MSA-...-ACS.	●
HNSA-RB80-SDL/R-ACS	50	60	80	20	33,8	68,3	MSA-...-ACS.	●

Modul / Module / Modulo

DF_{max} = Maximaler Futterdurchmesser und AKL = Auskräglänge bei Modul MSA-... / DF_{max} = maximum chuck diameter and AKL = Overhang length with modules MSA-... / DF_{max} = Diametro max mandrino e AKL = Lunghezza totale con modulo MSA-...

Bezeichnung Designation Articolo	HNSA-RB62...		HNSA-RB80...	
	AKL	DF_{max}	AKL	DF_{max}
MSA-...-32-ACS.	82,0	135	87,0	140
MSA-...-44-ACS.	87,0	145	92,0	150
MSA-...-52-ACS.	97,5	165	102,5	170
MSA-...-65-ACS.	97,5	165	102,5	170
MSA-...-69-ACS.	99,5	165	104,5	175
MSA-...-80-ACS.	105,0	180	110,0	185
MSA-...-90-ACS.	110,0	190	115,0	195
MSA-...-105-ACS.	118,0	205	123,0	210

Hinweis: Passende Module finden Sie im Kapitel SA (Seite 114 bis 128)

Remark: For modules to suit please see chapter SA (Page 114 to 128)

Nota: Per I moduli abbinabili vedere pagine da 114 a 128

Ersatzteile / Spare Parts / Ricambi

Trägerwerkzeug Holder Utensile	Schraube für Modul Screw for module Vite per modulo	Schlüssel Key Chiave	O-Ring O-ring O-Ring	Kühlmitteldüse Coolant jet Ugello refrigerante
HNSA-RB62-SD.-ACS	AS 0070	T5220-IP	OR 8X1,5 P	KMD 0825-3E
HNSA-RB80-SD.-ACS	AS 0070	T5220-IP	OR 8X1,5 P	KMD 0825-3E

Ersatzteile / Spare Parts / Ricambi

Modul Module Modulo	Schraube für Modul Screw for module Vite per modulo	Schlüssel Key Chiave
MSA-...-	SA5T	T5220-IP

Einbaumöglichkeiten / Assembly options / Combinazioni di montaggio

Linker Halter Left-hand holder Adattatore sinistro		Rechter Halter Right-hand holder Adattatore destro	
HNSA-RB62_SDL-ACS	HNSA-RB62_SDL-ACS	HNSA-RB62-SDR-ACS	HNSA-RB62-SDR-ACS
HNSA-RB80-SDL-ACS	HNSA-RB80-SDL-ACS	HNSA-RB80-SDR-ACS	HNSA-RB80-SDR-ACS
Linkes Modul montiert Left module shown Modulo sinistro in figura	Rechtes Modul montiert Right module shown Modulo destro in figura	Linkes Modul montiert Left module shown Modulo sinistro in figura	Rechtes Modul montiert Right module shown Modulo destro in figura
Einbaulage normal Normal assembly Montaggio normale	Einbaulage normal Normal assembly Montaggio normale	Einbaulage normal Normal assembly Montaggio normale	Einbaulage normal Normal assembly Montaggio normale
Einbaulage Überkopf Upside down assembly Montaggio invertito	Einbaulage Überkopf Upside down assembly Montaggio invertito	Einbaulage Überkopf Upside down assembly Montaggio invertito	Einbaulage Überkopf Upside down assembly Montaggio invertito

Hinweis: Sonderabmessungen und Abstechhalter für andere Maschinenhersteller auf Anfrage erhältlich. Ein Anfrageblatt hierzu finden Sie auf Seite 578 oder im Internet unter: www.arno.de/service/downloads

Remark: Custom made part-off holders for other machine manufacturers are available on request. Please complete enquiry sheet on page 578 or download this from www.arno.de/service/downloads

Nota: Adattatori speciali di differenti dimensioni e caratteristiche disponibili a richiesta. Vedere modulo richiesta a Pagina 578 o download del modulo da: www.arno.de/service/downloads

MS22 / MS32-40 / MS52 - mit Innenkühlung und ACS
 MS22 / MS32-40 / MS52 - with internal coolant and ACS
 MS22 / MS32-40 / MS52 - con refrigerazione interna e ACS

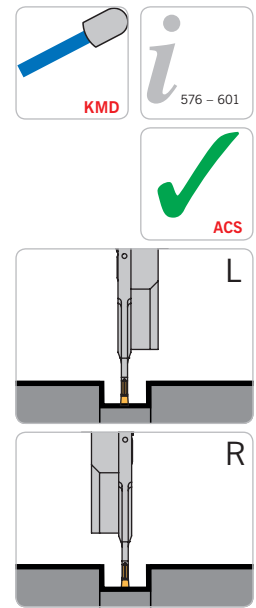
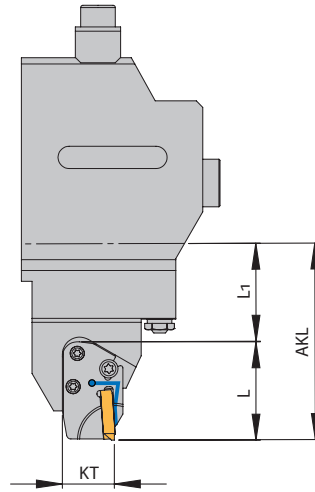
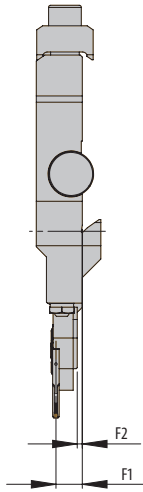

Linke Ausführung abgebildet
 Linkes Modul montiert
 Halter höheninstellbar
 Left-hand execution shown
 Left module shown
 Height adjustable holder
 Versione sinistra in figura
 Modulo sinistro in altezza
 Adattatore regolabile in altezza



Grundhalter / Basic holder / Adattore

Bezeichnung Designation Articolo	Schnittstelle Location Grandezza accoppiamento	L1	F1	F2	KT	Modul Module Modulo	PG 43
MS22-W5190231-MSA-IN-ACS	MS22	44,2	8,4	-2,0	24	MSA-IL/ILL-...ACS.	●
MS32-40-W5190233-MSA-IN-ACS	MS32-40	45,5	12,9	2,5	24	MSA-IL/ILL-...ACS.	●
MS52-W5190260-MSA-IL-ACS	MS 52	35,5	8,9	0,5	24	MSA-IL/ILL-...ACS.	●
MS52-W5190261-MSA-IR-ACS	MS 52	35,5	2,1	0,5	24	MSA-IR/IRR-...ACS.	●
MS52-W5190244-MSA-IN-ACS	MS52	67,5	6,9	-3,5	24	MSA-IL/ILL-...ACS.	●

Modul / Module / Modulo

AKL (Auskräglänge) = L (Länge des Moduls) + L1 / AKL (overhang length) = L (length of module) + L1 /
 AKL (lunghezza totale) = L (lunghezza modulo) + L1

Bezeichnung Designation Articolo	MS22...	MS32-40...	MS52... kurz MS52... short MS52... corto	MS52... lang MS52... long MS52... lungo
	AKL	AKL	AKL	AKL
MSA-I...SA1602-L45,5-22-ACS.	89,7	-	-	-
MSA-I...SA2402-L45,5-32-ACS.	-	91	-	-
MSA-I...SA2402-L48,5-42-ACS.	-	94	-	-
MSA-I...SA2403-L45,5-32-ACS.	-	91	-	-
MSA-I...SA2403-L48,5-42-ACS.	-	94	-	-
MSA-I...SA3502-L55-52-ACS.	-	-	90,5	-
MSA-I...SA3502-L55-52-ACS.	-	-	90,5	-
MSA-I...SA3503-L55-52-ACS.	-	-	90,5	-
MSA-I...SA3503-L55-52-ACS.	-	-	90,5	-
MSA-I...SA3502-L55-52-ACS.	-	-	-	122,5
MSA-I...SA3503-L55-52-ACS.	-	-	-	122,5



Hinweis: Passende Module finden Sie im Kapitel SA (Seite 114 bis 128)
 Remark: For modules to suit please see chapter SA (Page 114 to 128)
 Nota: Per i moduli abbinabili vedere pagine da 114 a 128

Ersatzteile / Spare Parts / Ricambi

Trägerwerkzeug Holder Utensile	Schraube für Modul Screw for module Vite per modulo	Schlüssel Key Chiave
MS..	2 x AS 0049 / AS 0050 *	T5220-IP

* Alternativ AS 0050D (doppelseitig IP20)
 * Alternatively AS 0050D (double sided IP20)
 * Alternativo AS 0050D (bilateralmente IP20)

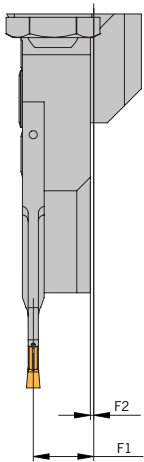
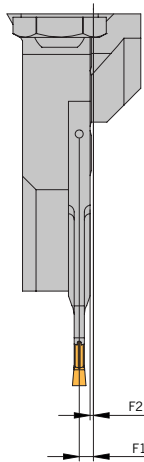
Einbaumöglichkeiten / Assembly options / Combinazioni di montaggio

Linker Halter Left-hand holder Adattatore sinistro	Rechter Halter Right-hand holder Adattatore destro
MS22-W5190231-MSA-IN-ACS	MS52-W5190261-MSA-IR-ACS
MS32-40-W5190233-MSA-IN-ACS	
MS52-W5190260-MSA-IL-ACS	
MS52-W5190244-MSA-IN-ACS	
	
Linkes Modul montiert Left module shown Modulo sinistro in figura	Rechtes Modul montiert Right module shown Modulo destro in figura
	
Einbaulage normal Normal assembly Montaggio normale	Einbaulage normal Normal assembly Montaggio normale

Hinweis: Sonderabmessungen und Abstechhalter für andere Maschinenhersteller auf Anfrage erhältlich. Ein Anfrageblatt hierzu finden Sie auf Seite 578 oder im Internet unter: www.arno.de/service/downloads

Remark: Custom made part-off holders for other machine manufacturers are available on request. Please complete enquiry sheet on page 578 or download this from www.arno.de/service/downloads

Nota: Adattatori speciali di differenti dimensioni e caratteristiche disponibili a richiesta. Vedere modulo richiesta a Pagina 578 o download del modulo da: www.arno.de/service/downloads

--> **Anwendungshinweise finden Sie auf S. 600/601**

--> *For application reference please see page 600/601*

--> *Per suggerimenti tecnici vedere pagina 600/601*

GWS02/GWS09/GWS41 - mit Innenkühlung und ACS
 GWS02/GWS09/GWS41 - with internal coolant and ACS
 GWS02/GWS09/GWS41 - con refrigerazione interna e ACS

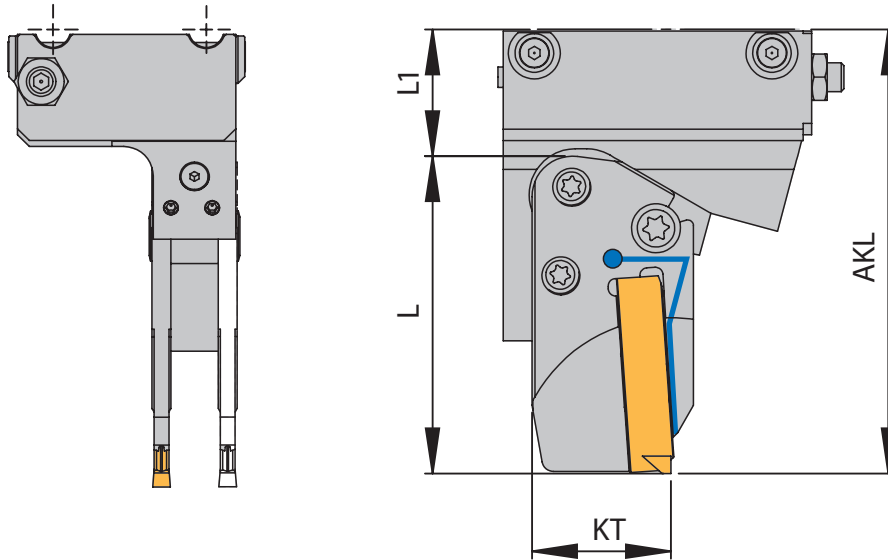
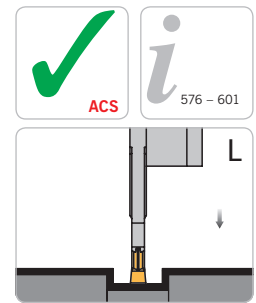

Rechter Halter und
 linkes Modul montiert
 Halter höhenstellbar
 Rechtes Modul alternativ
 Right holder and left module shown
 Height adjustable holder
 Right module alternative
 Adattatore destro e
 modulo sinistro in figura
 Adattatore registrabile in altezza
 Modulo destro alternativa

Grundhalter / Basic holder / Adattore

Bezeichnung Designation Articolo	Schnittstelle Location Grandezza accoppiamento	L1	F1	F2	KT	Modul Module Modulo	PG 43
GWS02R-EQ02001-MSA-IN-ACS	GWS02	14	3,6	7,6	24	MSA-I.-...-ACS.	●
GWS02R-EQ02002-MSA-IN-ACS	GWS02	22	3,6	7,6	24	MSA-I.-...-ACS.	●
GWS09R-EQ09001-MSA-IN-ACS	GWS09	14	3,6	7,6	24	MSA-I.-...-ACS.	●
GWS41R-EQ41002-MSA-IN-ACS	GWS41	22	3,6	7,6	24	MSA-I.-...-ACS.	●
GWS41L-EQ41001-MSA-IN-ACS	GWS41	22	3,6	7,6	24	MSA-I.-...-ACS.	●

Modul / Module / Modulo

AKL (Auskräglänge) = L (Länge des Moduls) + L1 / AKL (overhang length) = L (length of module) + L1 /
 AKL (lunghezza totale) = L (lunghezza modulo) + L1

Modul Module Modulo	GWS02R-EQ02001...	GWS02R-EQ02002...	GWS09R-EQ09001...	GWS41R-EQ41002...	GWS41L-EQ41001...
MSA-I.-L37-...-ACS.	51,0	59,0	51,0	59,0	59,0
MSA-I.-L41-...-ACS.	55,0	63,0	55,0	63,0	63,0
MSA-I.-L43,5-...-ACS.	57,0	65,5	57,5	65,5	65,5
MSA-I.-L44-...-ACS.	58,0	66,0	58,0	66,0	66,0
MSA-I.-L45,5-...-ACS.	59,5	67,5	59,5	67,5	67,5
MSA-I.-L48,5-...-ACS.	62,5	70,5	62,5	70,5	70,5
MSA-I.-L55-...-ACS.	69,0	77,0	69,0	77,0	77,0

Hinweis: Passende Module finden Sie im Kapitel SA (Seite 114 bis 128)

Remark: For modules to suit please see chapter SA (Page 114 to 128)

Nota: Per i moduli abbinabili vedere pagine da 114 a 128

Ersatzteile / Spare Parts / Ricambi





Trägerwerkzeug Holder Utensile	Schraube für Modul Screw for module Vite per modulo	Schlüssel Key Chiave
GWS..	2 x AS 0049 / 1 x AS 0050 *	T5220-IP

* Alternativ AS 0050D (doppelseitig IP20)

* Alternatively AS 0050D (double sided IP20)

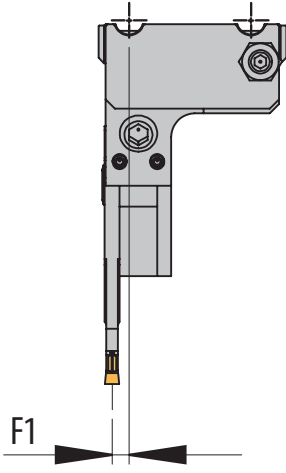
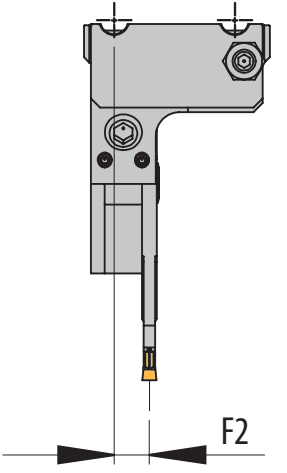
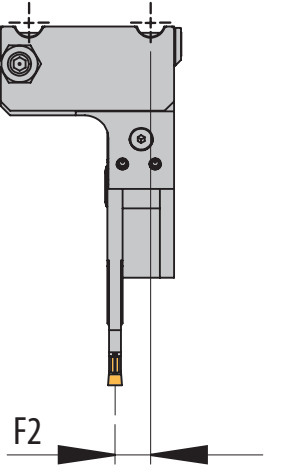
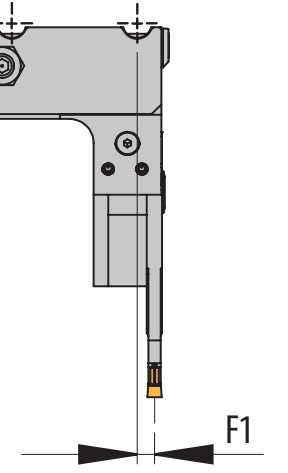
* Alternativo AS 0050D (bilateralmente IP20)

Einbaumöglichkeiten / Assembly options / Combinazioni di montaggio

Linker Halter Left-hand holder Adattatore sinistro		Rechter Halter Right-hand holder Adattatore destro	
GWS41L-EQ41001-MSA-IN-ACS	GWS41L-EQ41001-MSA-IN-ACS	GWS02R-EQ02001-MSA-IN-ACS	GWS02R-EQ02001-MSA-IN-ACS
		GWS02R_EQ02002-MSA-IN-ACS	GWS02R_EQ02002-MSA-IN-ACS
		GWS09R-EQ09001-MSA-IN-ACS	GWS09R-EQ09001-MSA-IN-ACS
		GWS41R-EQ41002-MSA-IN-ACS	GWS41R-EQ41002-MSA-IN-ACS
			
Linkes Modul montiert Left module shown Modulo sinistro in figura	Rechtes Modul montiert Right module shown Modulo destro in figura	Linkes Modul montiert Left module shown Modulo sinistro in figura	Rechtes Modul montiert Right module shown Modulo destro in figura
			
Einbaulage normal Normal assembly Montaggio normale	Einbaulage normal Normal assembly Montaggio normale	Einbaulage normal Normal assembly Montaggio normale	Einbaulage normal Normal assembly Montaggio normale

Hinweis: Mit einem Halter sind alle abgebildeten Varianten montierbar.

Remark: All shown options are available with only one holder.

Nota: E' sufficiente un solo corpo base per comporre tutte le combinazioni raffigurate.

Hinweis: Sonderabmessungen und Abstechhalter für andere Maschinenhersteller auf Anfrage erhältlich.
 Ein Anfrageblatt hierzu finden Sie auf Seite 578 oder im Internet unter: www.arno.de/service/downloads

Remark: Custom made part-off holders for other machine manufacturers are available on request.

Please complete enquiry sheet on page 578 or download this from www.arno.de/service/downloads

Nota: Adattatori speciali di differenti dimensioni e caratteristiche disponibili a richiesta.

Vedere modulo richiesta a Pagina 578 o download del modulo da: www.arno.de/service/downloads

--> Anwendungshinweise finden Sie auf S. 600/601

--> For application reference please see page 600/601

--> Per suggerimenti tecnici vedere pagina 600/601

GWS02 - mit ACS

GWS02 - with ACS

GWS02 - con ACS

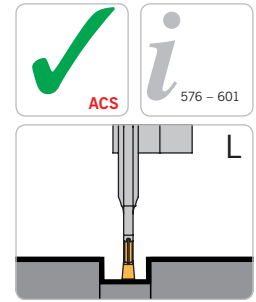
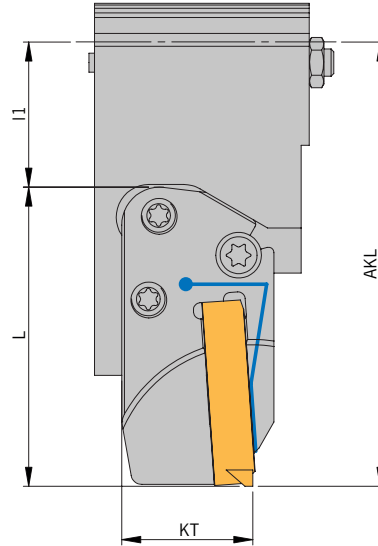
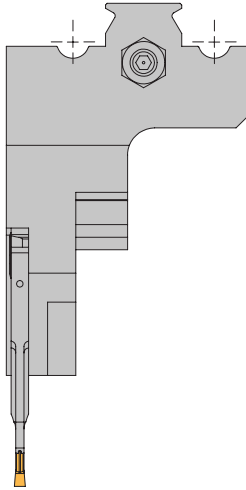

Linker Halter und linkes Modul montiert
Halter höhenstellbar
 Left holder and left module shown
 Height adjustable holder
 Adattatore sinistro e modulo sinistro in figura
 Adattatore registrabile in altezza

N NEU/NEW/NUOVO

Grundhalter / Basic holder / Adattore

Bezeichnung Designation Articolo	Schnittstelle Location Grandezza accoppiamento	L1	F1	KT	Modul Module Modulo	PG 43
GWS202L-EQ202001-MSA-IN-ACS	GWS202	26,5	35,8	24	MSA-IL/ILL...-ACS.	●

Modul / Module / Modulo

AKL (Auskrüglänge) = L (Länge des Moduls) + L1 / AKL (overhang length) = L (length of module) + L1 /
AKL (lunghezza totale) = L (lunghezza modulo) + L1

Modul Module Modulo	GWS202... AKL
MSA-I.-L37...-ACS.	63,5
MSA-I.-L41...-ACS.	67,5
MSA-I.-L43,5...-ACS.	69,0
MSA-I.-L44...-ACS.	70,5
MSA-I.-L45,5...-ACS.	72,0
MSA-I.-L48,5...-ACS.	75,0
MSA-I.-L55-52...-ACS.	81,5

Hinweis: Passende Module finden Sie im Kapitel SA (Seite 114 bis 128)

Remark: For modules to suit please see chapter SA (Page 114 to 128)

Nota: Per I moduli abbinabili vedere pagine da 114 a 128

Ersatzteile / Spare Parts / Ricambi

Trägerwerkzeug Holder Utensile	Schraube für Modul Screw for module Vite per modulo	Schlüssel Key Chiave
GWS..	1 x AS 0049 / 2 x AS 0050*	T5220-IP

* Alternativ AS 0050D (doppelseitig IP20)

* Alternatively AS 0050D (double sided IP20)

* Alternativo AS 0050D (bilateralmente IP20)

Einbaumöglichkeiten / Assembly options / Combinazioni di montaggio

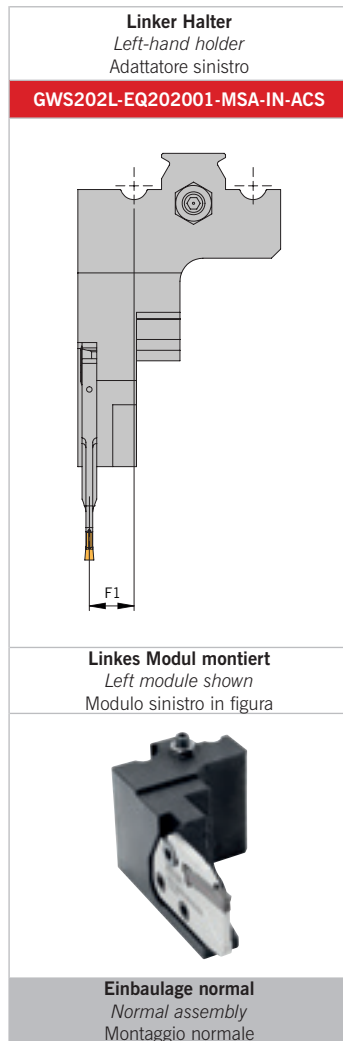

**Hinweis: Sonderabmessungen und Abstechhalter für andere Maschinenhersteller auf Anfrage erhältlich.
Ein Anfrageblatt hierzu finden Sie auf Seite 578 oder im Internet unter: www.arno.de/service/downloads**

*Remark: Custom made part-off holders for other machine manufacturers are available on request.
Please complete enquiry sheet on page 578 or download this from www.arno.de/service/downloads*

*Nota: Adattatori speciali di differenti dimensioni e caratteristiche disponibili a richiesta.
Vedere modulo richiesta a Pagina 578 o download del modulo da: www.arno.de/service/downloads*

--> **Anwendungshinweise finden Sie auf S. 600/601**

--> *For application reference please see page 600/601*

--> *Per suggerimenti tecnici vedere pagina 600/601*

Ersatzteile und Zubehör

Spare parts and accessories
Ricambi e accessori

Abstechhalter und Direktaufnahmen

Part-off holders and flange mounted holders
Adattatori di troncatura e attacchi base

Artikel / Item / Articolo	PG 11
Kühlmitteldüse / Coolant jet / Ugello refrigerante	
KMD 0830	●
KMD 0519	●
KMD 0825-3E	●
KMD 0820-4BJ	●
KMD 0516	●

Artikel / Item / Articolo	PG 11
Schraube für Kühlmitteldüse / Screw for coolant jet / Vite per ugello refrigerante	
AS 0020	●

Artikel / Item / Articolo	PG 11
Schraube für Modul / Screw for module / Vite per modulo	
AS 0070	●
AS 0022	●
AS 0049	●
AS 0050	●
AS 0050D	●

Artikel / Item / Articolo	PG 11
Schlüssel / Key / Chiave	
T5220-IP	●
T5115-IP	●
T5120-IP	●
T5215-IP	●
KP 1321	●
KP 5421	●

Artikel / Item / Articolo	PG 11
Verschluss-Stift / Locking ring / Anello di tenuta	
ZS0820G	●
ZS0512G	●
ZS0818	●

Artikel / Item / Articolo	PG 11
Zylinderkopfschraube / Cylinder head screw / Vite a testa cilindrica	
DIN912-M3X3-A2	●
AS 0049	●
AS 0050	●

Artikel / Item / Articolo	PG 11
O-Ring / O-Ring / O-Ring	
OR 8x1-NBR70	●
OR 23,6X1,8-NBR70	●
OR 28x1,8-NBR80	●
OR 30X2-N-NBR70	●
OR 7X2 P	●
OR 14,82X1,78-NBR70	●
OR 7X1,5 P	●
OR 8X1,5 P	●
OR 9X1,5 P	●
OR 22X3,5P	●
OR 10,82X1,78P	●
OR 18,77X1,78 P	●
OR 40X1,6 P	●
OR 14X1,5P	●
OR 36X2 P	●
OR 54X3 P	●

Artikel / Item / Articolo	PG 11
Spannschraube für Klemme / Span screw for clamp / Vite di arco per staffa	
DIN912-M4X12-12.9	●

Artikel / Item / Articolo	PG 14
Klemme / Clamp / Staffa	
K-HVDI-10-50	●

Artikel / Item / Articolo	PG 11
Nutenstein / T-slot fixture / T-slot slot	
NS 15/14X10X69	●
NS 20X9,7X15	●

Artikel / Item / Articolo	PG 11
Klemmleiste / Clamping strip / Morsettiera	
60AB3444	●
W67310.0624	●

Artikel / Item / Articolo	PG 11
Schraube / Screw / Vite	
DIN912 M5x16-12.9	●
DIN912 M6X20-12.9	●
G111	●
G104	●

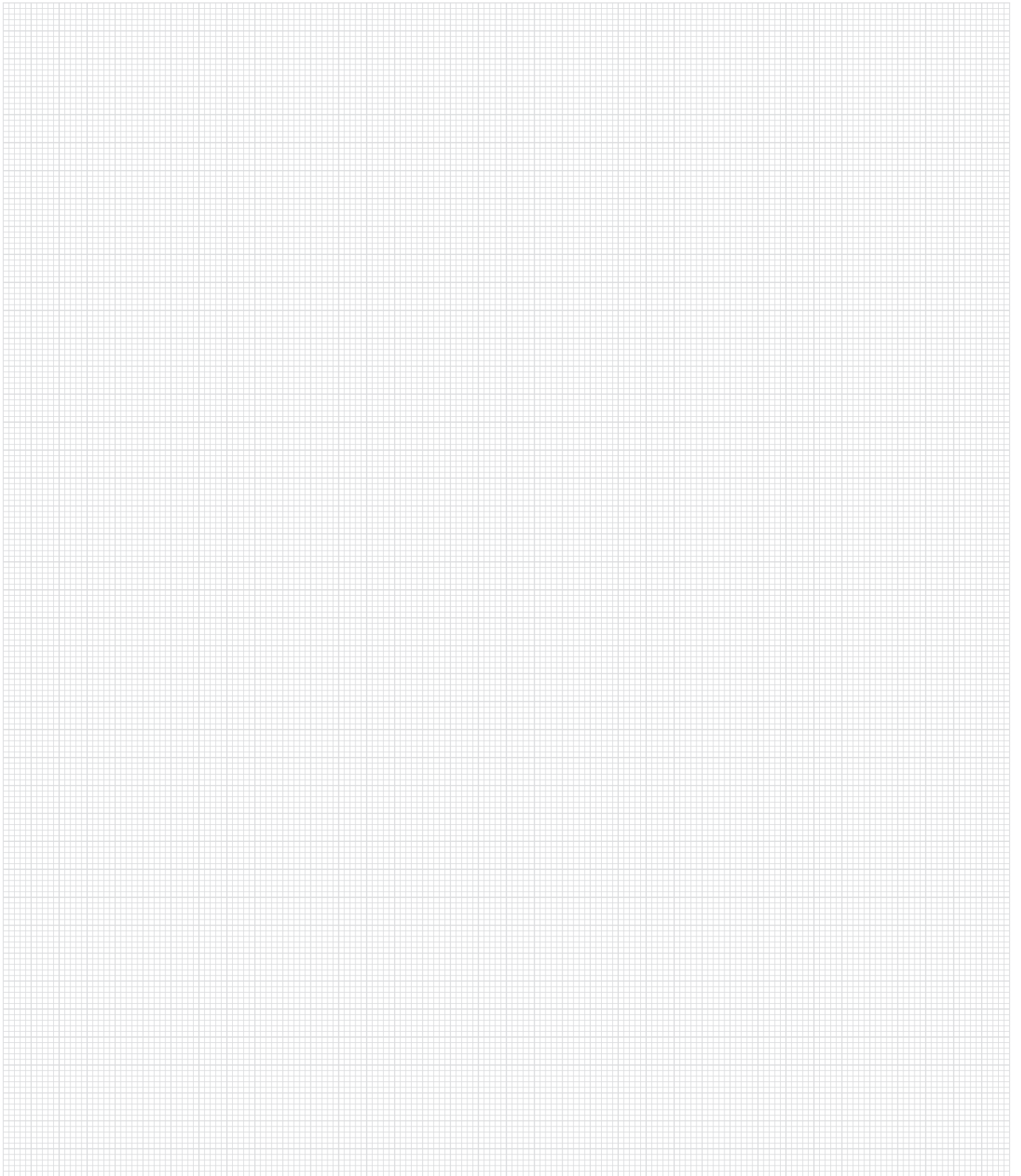

Weitere Informationen finden Sie unter:

For more information see:

Per maggiori informazioni visita il sito:

www.arno.de



Bei Anfragen für Sonderhalter bitte die folgenden Werte eintragen:



Maschine

Typ

Schnittstelle

Revolver/Anzahl der Plätze

Abstechposition Hauptspindel

Gegenspindel

Einbaulage* Normal

Überkopf

Futterdurchmesser mm

Max. Abstechdurchmesser mm

Werkzeuflänge AKL mm

Flugkreis des Revolvers mm

Maß F1 mm

Maß F2 mm

Modulbezeichnung:

Sonstige Bemerkungen:

.....

.....

.....

.....

Einbaulage*

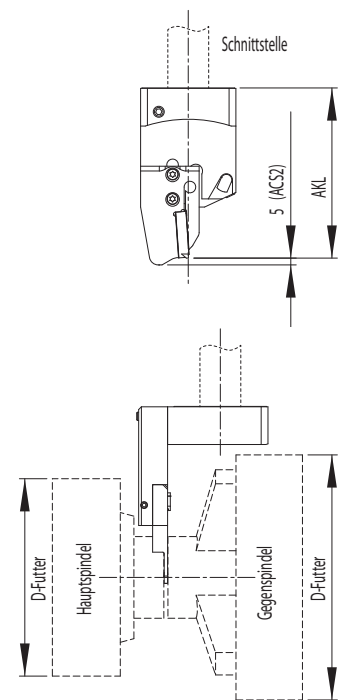

Linker Halter		Rechter Halter	
<input type="checkbox"/>	<input type="checkbox"/>	<input type="checkbox"/>	<input type="checkbox"/>
Linkes Modul montiert	Rechtes Modul montiert	Linkes Modul montiert	Rechtes Modul montiert

*Passende Module finden Sie auf Seite 46 bis 48.

Download dieses Formulars unter: www.arno.de/service/downloads



When enquiring about special holders please state the following dimensions:



Machine

Type

Location

Turret / number of tool posts

Part-off position Main spindle

Sub spindle

Assembly* Normal

Upside down

Chuck diameter mm

Maximum part-off diameter mm

Tool length AKL mm

Turret clearance mm

F1 dimension mm

F2 dimension mm

Module description

Other comments

.....

.....

.....

.....

Assembly*

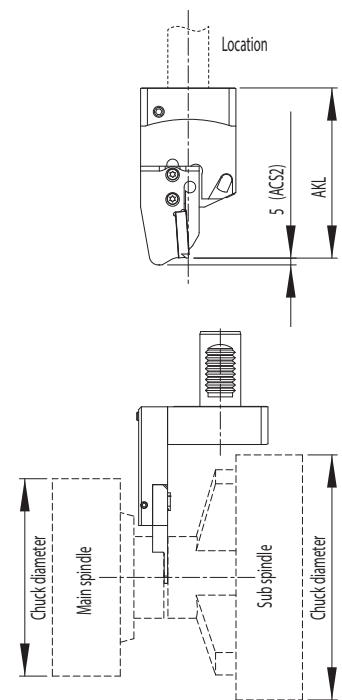

Left-hand holder		Right-hand holder	
<input type="checkbox"/>	<input type="checkbox"/>	<input type="checkbox"/>	<input type="checkbox"/>
Left module shown	Right module shown	Left module shown	Right module shown

*For modules to suit please see page 46 – 48.

Download this form from: www.arno.de/service/downloads



Per le richieste di adattatore speciale sono necessari i seguenti dati:



Macchina utensile:

Modello:

Dimensione attacco:

Torretta / Numero posizioni torretta:

Posizione di taglio: Mandrino principale

Contro-mandrino

Montaggio:* Normale

Rovesciati

Diametro ingombro mandrini: mm

Max diametro di troncatura: mm

Lunghezza utensile AKL: mm

Ingombro torretta in rotazione: mm

Dimensione F1: mm

Dimensione F2: mm

Note:

.....

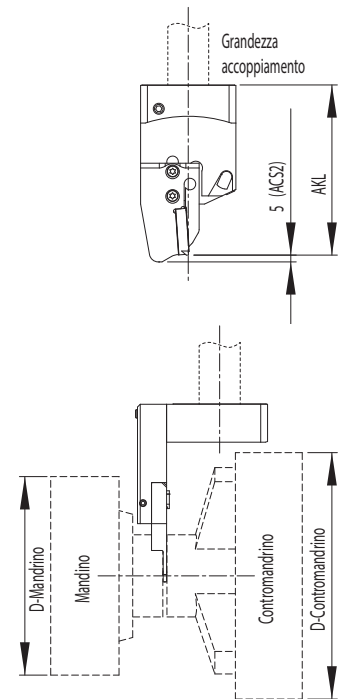

Montaggio:*

Adattatore sinistro		Adattatore destro	
<input type="checkbox"/>	<input type="checkbox"/>	<input type="checkbox"/>	<input type="checkbox"/>
Modulo sinistro in figura	Modulo destro in figura	Modulo sinistro in figura	Modulo destro in figura

*Per i moduli abbinabili vedere pagine da 46 – 48.

Download del formula da: www.arno.de/download

Systemübersicht KMH / System overview KMH/

Panoramica del sistema KMH

KMH – Werkzeughalter / KMH tool holder / Adattatori KMH

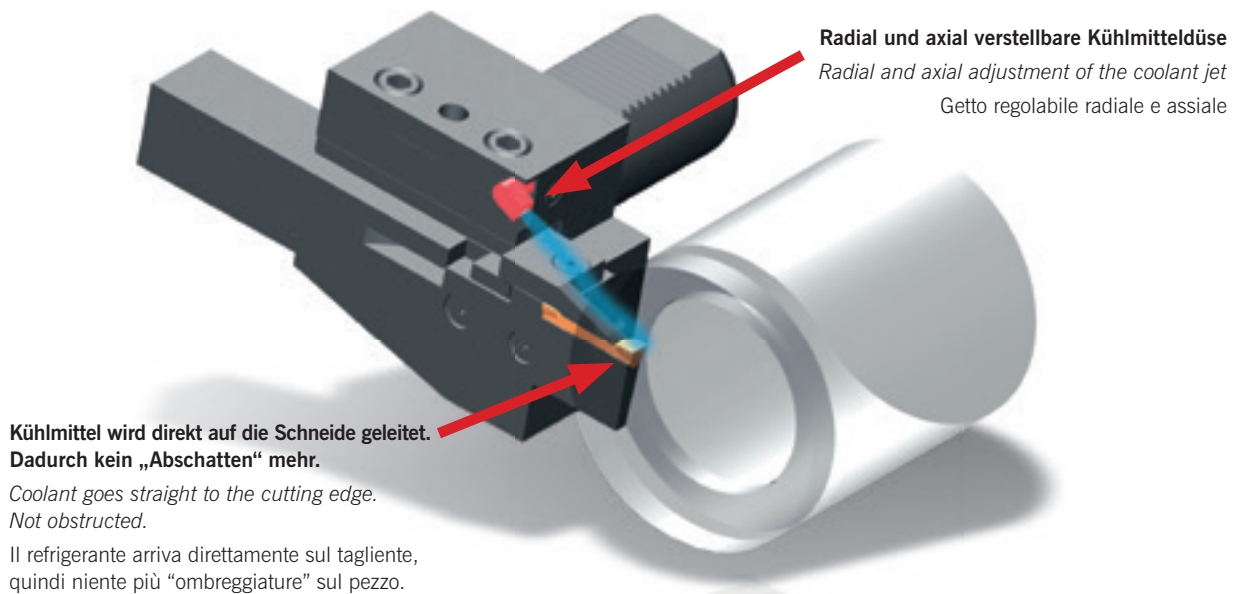

SBN Spannblock / SBN Parting block / SBN Blocco portalama

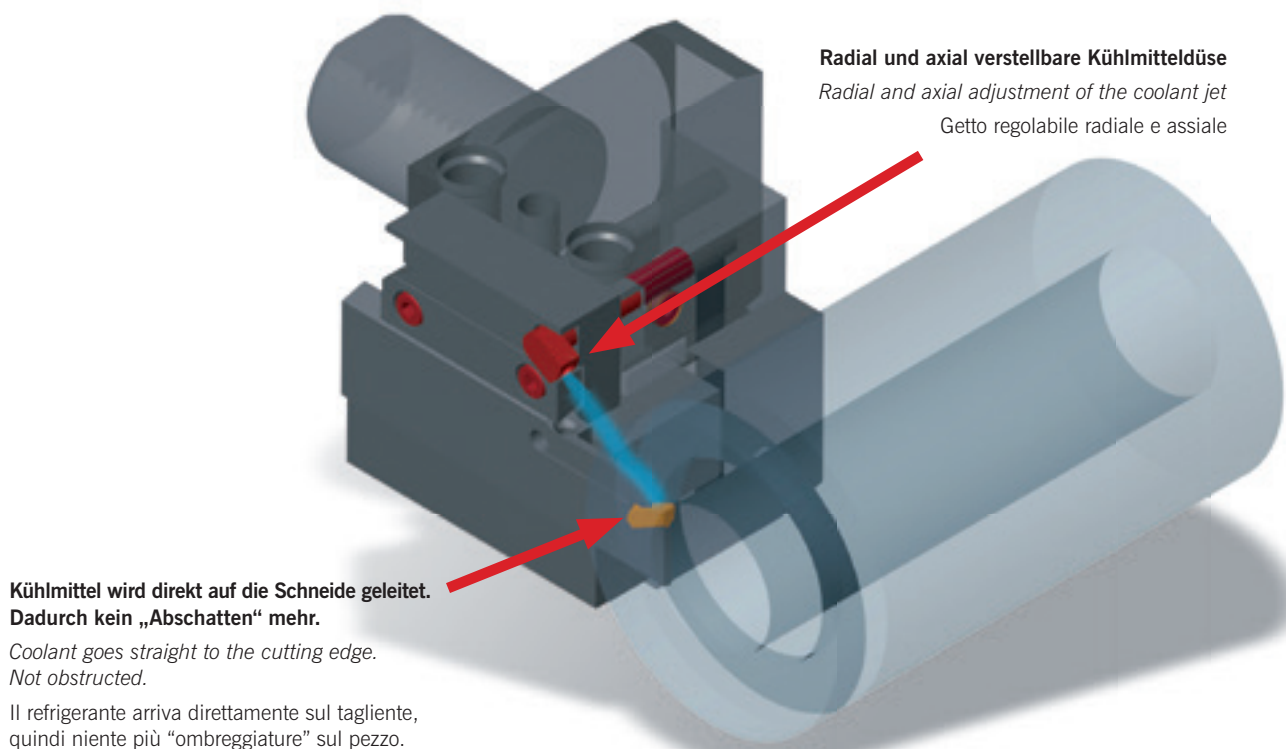

HVDI25 – Montagehinweis / Assembly instructions / Schema di montaggio

Option 1: Kühlung mit ACS2 / Option 1: Coolant with ACS2 / Opzione 1: Refrigerazione con ACS2

Montage des Verschlussstiftes mit Dichtring

Assembly of locking pin with sealing ring

Installazione del tappo con anello di tenuta

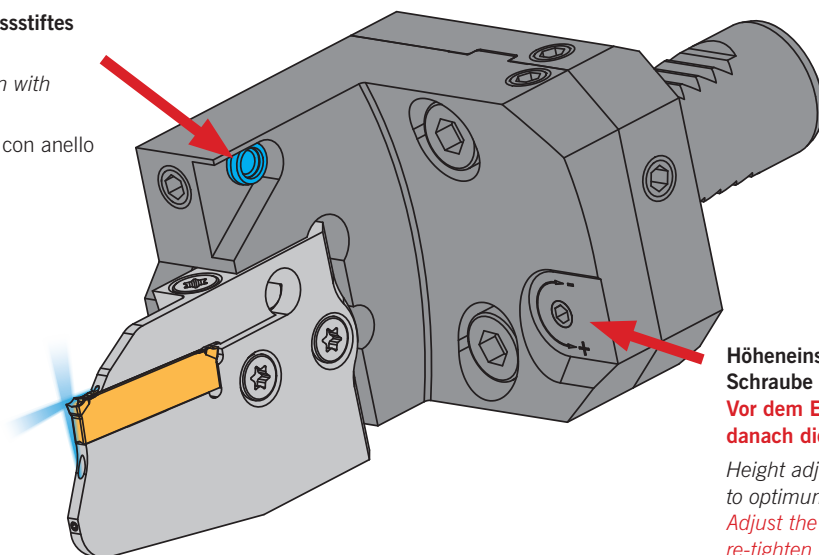

Höheneinstellbarkeit mittels Drehen der Schraube bis zur optimalen Spitzenhöhe. Vor dem Einsatz die Höhe einstellen und danach die Spanschrauben wieder anziehen.

Height adjustment by turning the screw to optimum insert height.

Adjust the height before use and then re-tighten the clamping screws.

Regolazione in altezza del tagliente mediante vite.

Regolare l'altezza prima dell'uso e poi stringere le viti di serraggio.

Option 2: Kühlung mit ACS2 und zusätzlicher Jet-Düse / Option 2: Coolant with ACS2 and additional coolant jet / Opzione 2: Refrigerazione con ACS2 e con normale ugello

Montage der Kühlmitteldüse (Jet-Düse)

Assembly of coolant jet

Montaggio dell'ugello refrigerante

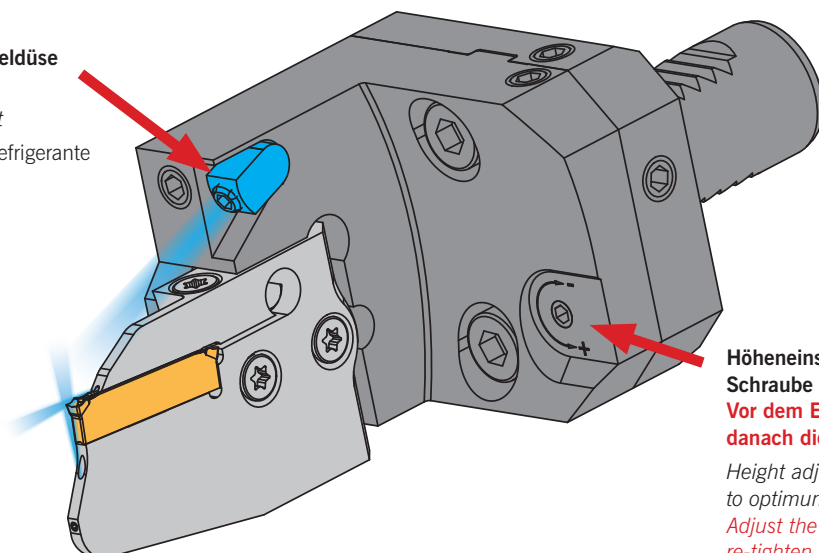

Höheneinstellbarkeit mittels Drehen der Schraube bis zur optimalen Spitzenhöhe. Vor dem Einsatz die Höhe einstellen und danach die Spanschrauben wieder anziehen.

Height adjustment by turning the screw to optimum insert height.

Adjust the height before use and then re-tighten the clamping screws.

Regolazione in altezza del tagliente mediante vite.

Regolare l'altezza prima dell'uso e poi stringere le viti di serraggio.

HVDI30 / HVDI40 – Montagehinweis / Assembly instructions / Schema di montaggio

Option 1: Kühlung mit ACS2 / Option 1: Coolant with ACS2 / Opzione 1: Refrigerazione con ACS2

Montage des Verschlussstiftes mit Dichtring

Assembly of locking pin with sealing ring
Installazione del tappo con anello di tenuta

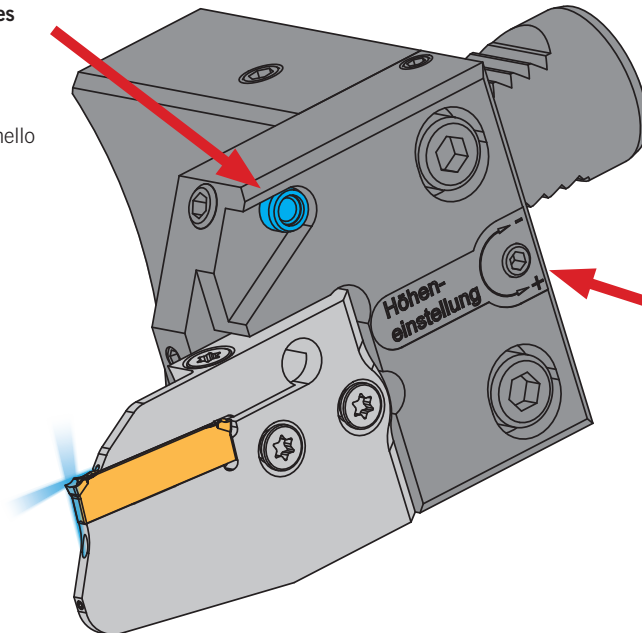

Höheneinstellbarkeit mittels Drehen der Schraube bis zur optimalen Spitzenhöhe. Vor dem Einsatz die Höhe einstellen und danach die Spanschrauben wieder anziehen.

Height adjustment by turning the screw to optimum insert height.

Adjust the height before use and then re-tighten the clamping screws.

Regolazione in altezza del tagliente mediante vite.

Regolare l'altezza prima dell'uso e poi stringere le viti di serraggio.

Option 2: Kühlung mit ACS2 und zusätzlicher Jet-Düse / Option 2: Coolant with ACS2 and additional coolant jet / Opzione 2: Refrigerazione con ACS2 e con normale ugello

Montage der Kühlmitteldüse (Jet-Düse)

Assembly of coolant jet
Montaggio dell'ugello refrigerante

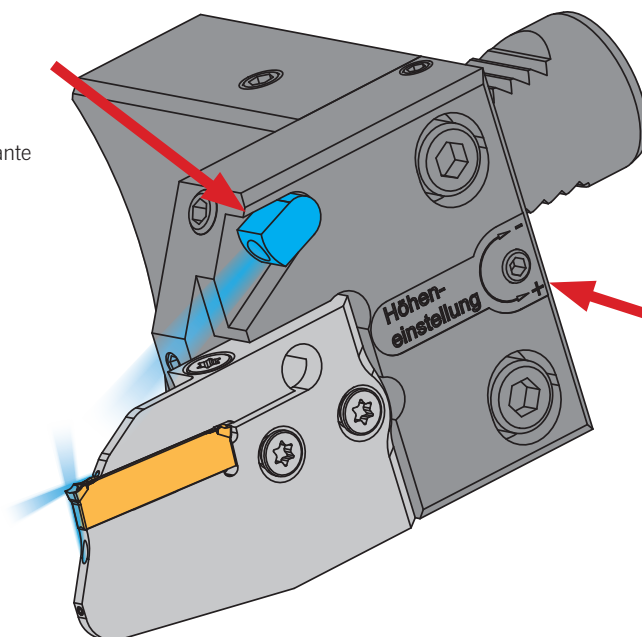

Höheneinstellbarkeit mittels Drehen der Schraube bis zur optimalen Spitzenhöhe. Vor dem Einsatz die Höhe einstellen und danach die Spanschrauben wieder anziehen.

Height adjustment by turning the screw to optimum insert height.

Adjust the height before use and then re-tighten the clamping screws.

Regolazione in altezza del tagliente mediante vite.

Regolare l'altezza prima dell'uso e poi stringere le viti di serraggio.

HVDS – Montagehinweis / Assembly instructions / Schema di montaggio

Option 1 – linkes Modul: Kühlung mit ACS2 und zusätzlicher Jet-Düse / Option 1 – left module: Cooling with ACS2 and additional Jet Nozzle / Opzione 1 – modulo sinistro: Raffreddamento con ACS2 ed ugelli supplementari

Falls kein zusätzlicher Kühlmittelstrahl durch die montierte Kühlmitteldüse erwünscht ist, bitte den Gewindestift lösen und die Düse entfernen. Dann den beigelegten Verschlussstift mittig einsetzen und den Gewindestift wieder festziehen.

If no coolant is wanted from the fitted coolant jet, please loosen threaded pin and remove jet and replace with enclosed locking pin and then fasten the threaded pin.

Nel caso in cui l'ugello di refrigerante esterno non venisse utilizzato, rimuovere l'ugello e chiudere il passaggio esterno con il tappo a tenuta dato in dotazione.

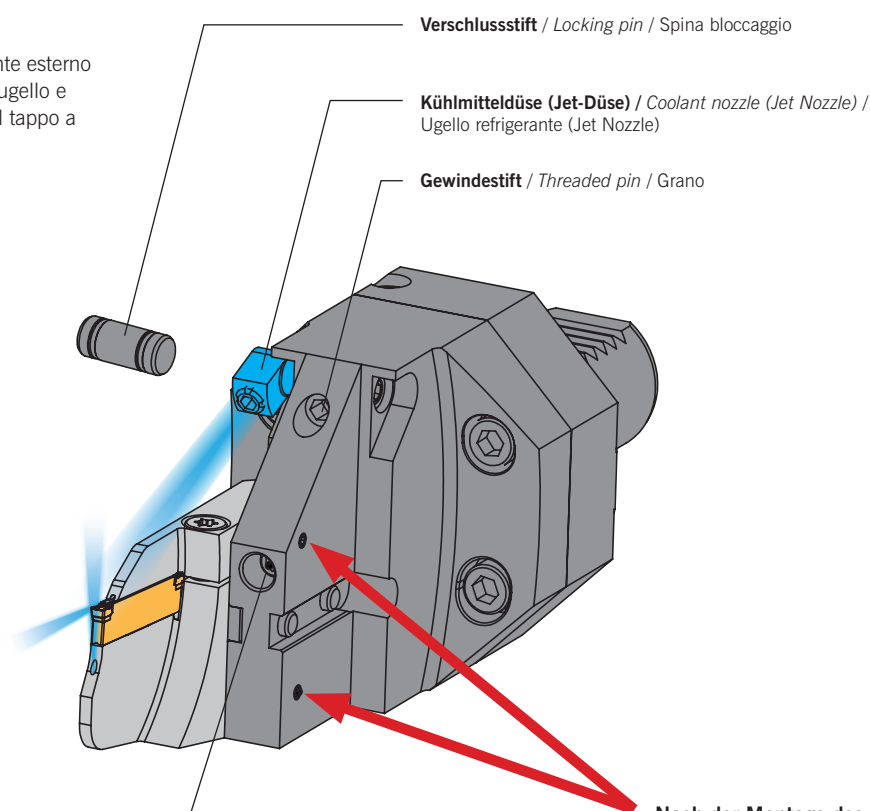

Hinweis für höhenstellbare Halter:
Bitte vor dem Einsatz die Höhe einstellen.
Höheneinstellung mittels drehen des Gewindestiftes. Danach Spanschrauben wieder anziehen.

*When using height-adjustable holders:
Please adjust the height before use.
Height can be adjusted by turning the threaded pin. Re-tighten the clamping screws.*

*Nota: per supporti regolabili in altezza,
regolare l'altezza prima dell'uso.
Regolazione in altezza ruotando il grano.
Stringere le viti di serraggio.*

Nach der Montage des Moduls bitte die offenen Kühlmittelbohrungen mit den beigelegten Schrauben verschließen.

After mounting the module, close the open coolant holes with the enclosed screws.

Nach der Montage des Moduls bitte die offenen Kühlmittelbohrungen mit den beigelegten Schrauben verschließen.

HVDS – Montagehinweis / Assembly instructions / Schema di montaggio

Option 2 – rechtes Modul: linkes Modul: Kühlung mit ACS2 und zusätzlicher Jet-Düse / Option 2 – right module: Cooling with ACS2 and additional Jet Nozzle / Opzione 2 – modulo destro: Raffreddamento con ACS2 ed ugelli supplementari

Falls kein zusätzlicher Kühlmittelstrahl durch die montierte Kühlmitteldüse erwünscht ist, bitte den Gewindestift lösen und die Düse entfernen. Dann den beigelegten Verschlussstift mittig einsetzen und den Gewindestift wieder festziehen.

If no coolant is wanted from the fitted coolant jet, please loosen threaded pin and remove jet and replace with enclosed locking pin and then fasten the threaded pin.

Nel caso in cui l'ugello di refrigerante esterno non venisse utilizzato, rimuovere l'ugello e chiudere il passaggio esterno con il tappo a tenuta dato in dotazione.

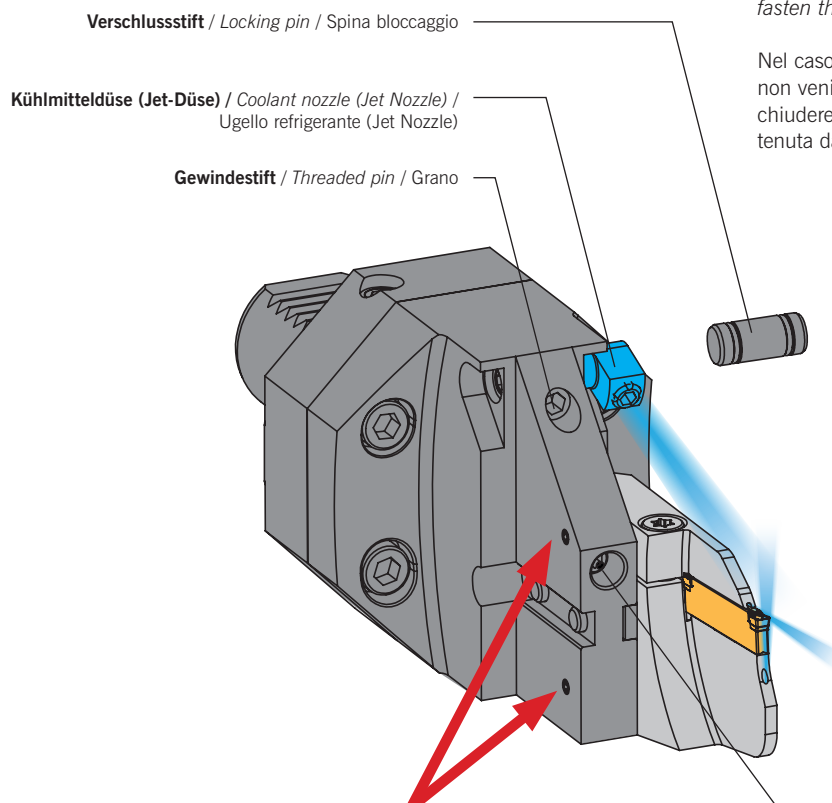

Nach der Montage des Moduls bitte die offenen Kühlmittelbohrungen mit den beigelegten Schrauben verschließen.

After mounting the module, close the open coolant holes with the enclosed screws.

Nach der Montage des Moduls bitte die offenen Kühlmittelbohrungen mit den beigelegten Schrauben verschließen.

Hinweis für höheninstellbare Halter: Bitte vor dem Einsatz die Höhe einstellen. Höheneinstellung mittels drehen des Gewindestiftes. Danach Spannschrauben wieder anziehen.

When using height-adjustable holders: Please adjust the height before use. Height can be adjusted by turning the threaded pin. Re-tighten the clamping screws.

Nota: per supporti regolabili in altezza, regolare l'altezza prima dell'uso. Regolazione in altezza ruotando il grano. Stringere le viti di serraggio.

HABC – Montagehinweis / Assembly instructions / Schema di montaggio

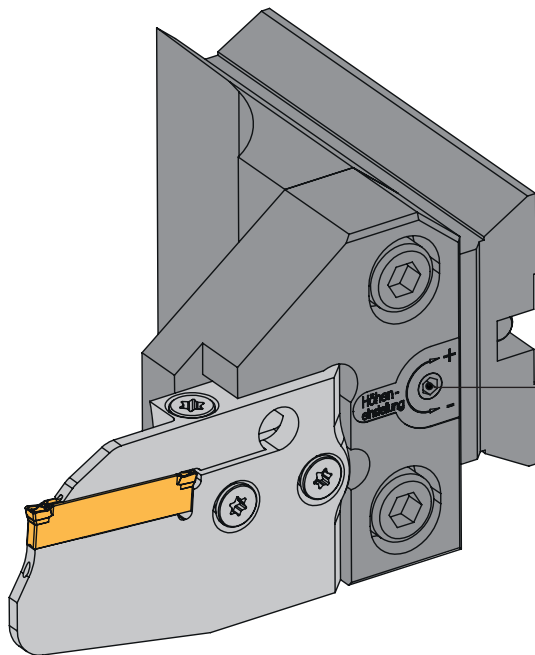

Hinweis für höhenstellbare Halter:
Bitte vor dem Einsatz die Höhe einstellen.
Höheneinstellung mittels drehen des
Gewindestiftes. Danach Spannschrauben
wieder anziehen.

*When using height-adjustable holders:
Please adjust the height before use.
Height can be adjusted by turning the
threaded pin. Re-tighten the clamping
screws.*

*Nota: per supporti regolabili in altezza,
regolare l'altezza prima dell'uso.
Regolazione in altezza ruotando il grano.
Stringere le viti di serraggio.*

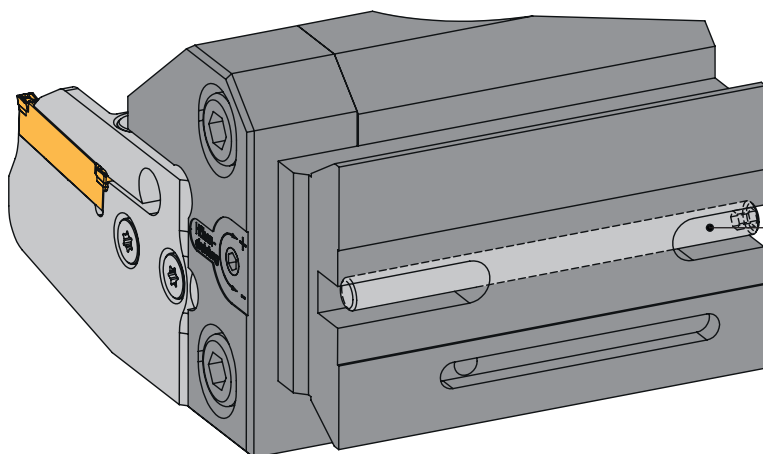

**Gewindesttift zur Verstellung am Revolver
in der Z-Achse am Werkzeugplatz.**

*Threaded pin for adjustment on turret
In the Z axis at the mounting location.*

*Per la regolazione altezza dalla torretta,
montare la vite in dotazione nella sede
di montaggio.*



**Sonderlösungen –
genau auf Sie zugeschnitten.**

*Special solutions especially
for your application!*

Soluzioni speciali –
su misura per voi.

**Sie haben eine Aufgabe –
wir haben die Lösung.**

Nutzen Sie unsere langjährige Erfahrung im Bereich der Sonderwerkzeuge und arbeiten Sie mit ARNO-Werkzeugen in Zukunft effektiver und kostengünstiger.

Ganz egal ob Sonderschneideinsätze oder komplexe Kombi-Werkzeuge – wir fertigen Ihnen flexibel, schnell und präzise nahezu jeden Wunsch.

*You have an application –
we have a solution.*

Take advantage of our many years' experience in special solutions and in future benefit from more efficient and cost effective ARNO tooling. Whether it is special inserts or complex combination tools – we are able to offer nearly any solutions.

**Hai un problema –
chiedici la nostra soluzione.**

La nostra pluriennale esperienza nell'ambito delle lavorazioni meccaniche ci rende capaci di offrire qualsiasi soluzione di lavorazione nell'ambito delle nostre competenze specifiche.

Sia per singoli inserti o utensili e sia per complete combinazioni di utensili.

Un servizio veloce, flessibile e preciso per ogni esigenza.

Weitere Informationen finden Sie unter:

For more information see:

Altre informazioni su:

www.arno.de

HDD – Montagehinweis / Assembly instructions / Schema di montaggio

Option 1 – linkes Modul: Kühlung mit ACS2 und zusätzlicher Jet-Düse / Option 1 – left module: Cooling with ACS2 and additional Jet Nozzle / Opzione 1 – modulo sinistro: Raffreddamento con ACS2 ed ugelli supplementari

Falls kein zusätzlicher Kühlmittelstrahl durch die montierte Kühlmitteldüse erwünscht ist, bitte den Gewindestift lösen und die Düse entfernen. Dann den beigelegten Verschlussstift mittig einsetzen und den Gewindestift wieder festziehen.

If no coolant is wanted from the fitted coolant jet, please loosen threaded pin and remove jet and replace with enclosed locking pin and then fasten the threaded pin.

Nel caso in cui l'ugello di refrigerante esterno non venisse utilizzato, rimuovere l'ugello e chiudere il passaggio esterno con il tappo a tenuta dato in dotazione.

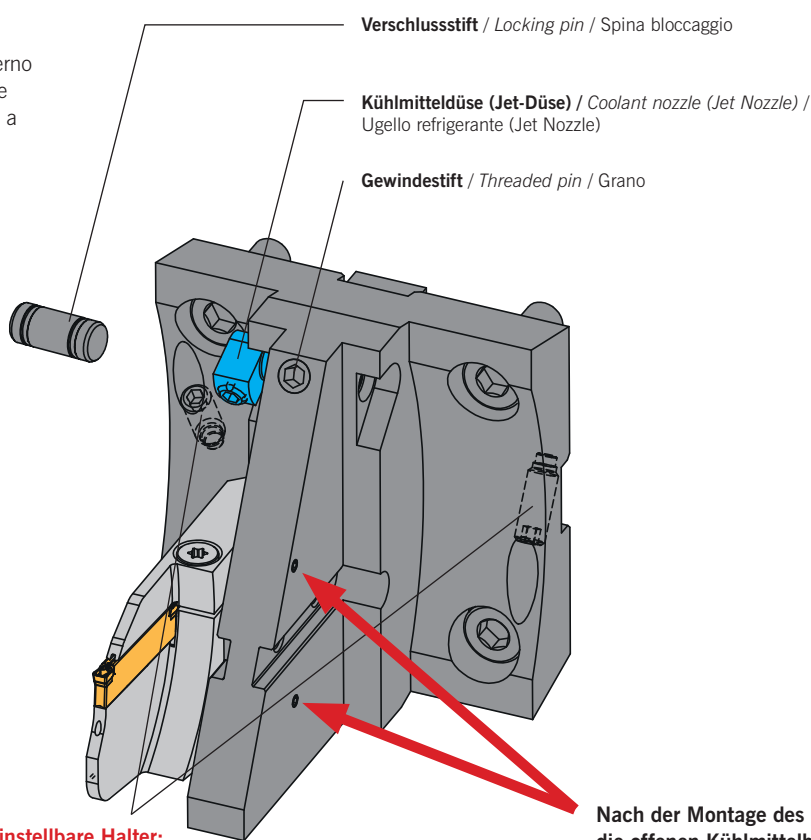

Hinweis für höheneinstellbare Halter:
Bitte vor dem Einsatz die Höhe einstellen.
Höheneinstellung mittels drehen des Gewindestiftes. Danach Spanschrauben wieder anziehen.

When using height-adjustable holders:
Please adjust the height before use.
Height can be adjusted by turning the threaded pin. Re-tighten the clamping screws.

Nota: per supporti regolabili in altezza,
regolare l'altezza prima dell'uso.
Regolazione in altezza ruotando il grano.
Stringere le viti di serraggio.

Nach der Montage des Moduls bitte die offenen Kühlmittelbohrungen mit den beigelegten Schrauben verschließen.

After mounting the module, close the open coolant holes with the enclosed screws.

Nach der Montage des Moduls bitte die offenen Kühlmittelbohrungen mit den beigelegten Schrauben verschließen.

HDD – Montagehinweis / Assembly instructions / Schema di montaggio

Option 2 – rechtes Modul: Kühlung mit ACS2 und zusätzlicher Jet-Düse / Option 2 – right module:

Cooling with ACS2 and additional Jet Nozzle / Opzione 2 – modulo destro: Raffreddamento con ACS2 ed ugelli supplementari

Falls kein zusätzlicher Kühlmittelstrahl durch die montierte Kühlmitteldüse erwünscht ist, bitte den Gewindestift lösen und die Düse entfernen. Dann den beigelegten Verschlussstift mittig einsetzen und den Gewindestift wieder festziehen.

If no coolant is wanted from the fitted coolant jet, please loosen threaded pin and remove jet and replace with enclosed locking pin and then fasten the threaded pin.

Nel caso in cui l'ugello di refrigerante esterno non venisse utilizzato, rimuovere l'ugello e chiudere il passaggio esterno con il tappo a tenuta dato in dotazione.

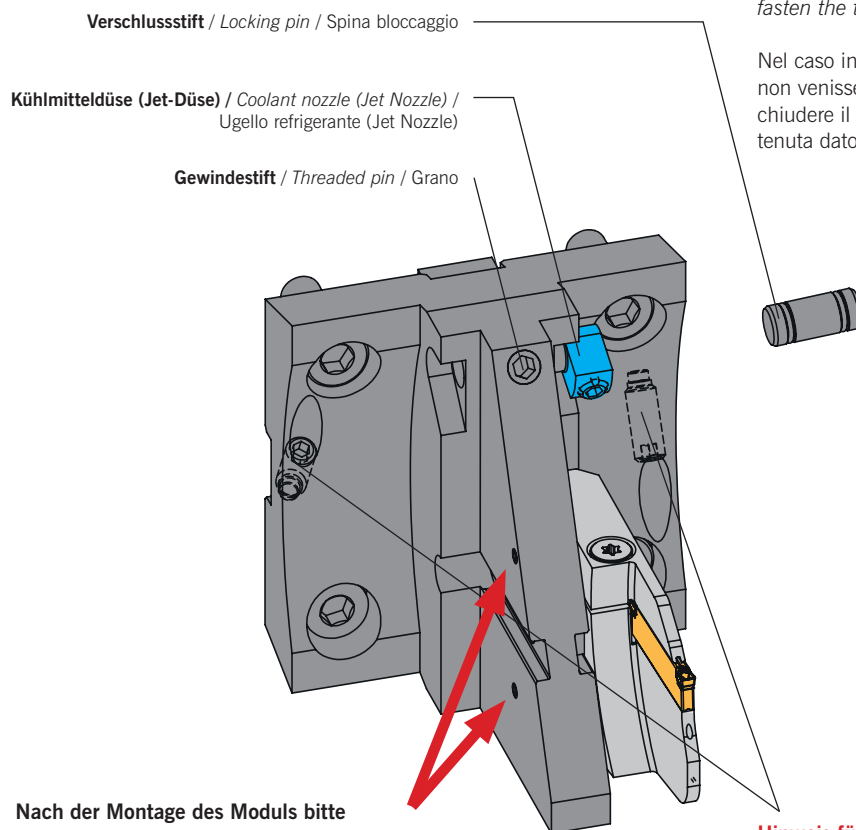

Nach der Montage des Moduls bitte die offenen Kühlmittelbohrungen mit den beigelegten Schrauben verschließen.

After mounting the module, close the open coolant holes with the enclosed screws.

Nach der Montage des Moduls bitte die offenen Kühlmittelbohrungen mit den beigelegten Schrauben verschließen.

Hinweis für höheninstellbare Halter:
Bitte vor dem Einsatz die Höhe einstellen.
Höheneinstellung mittels drehen des Gewindestiftes. Danach Spannschrauben wieder anziehen.

When using height-adjustable holders:
Please adjust the height before use.
Height can be adjusted by turning the threaded pin. Re-tighten the clamping screws.

Nota: per supporti regolabili in altezza,
regolare l'altezza prima dell'uso.
Regolazione in altezza ruotando il grano.
Stringere le viti di serraggio.

HDD – Montagehinweis / Assembly instructions / Schema di montaggio

Option 1: Höheneinstellbar / Option 1: Height adjustable / Opzione 1: altezza regolabile

Hinweis für höheneinstellbare Halter:
Bitte vor dem Einsatz die Höhe einstellen.

Hier am Beispiel: HDD-BMT45-SDS-ACS

When using height-adjustable holders:
Please adjust the height before use.

Example: HDD-BMT45-SDS-ACS

Nota: per supporti regolabili in altezza,
regolare l'altezza prima dell'uso.

Esempio: HDD BMT45 SDS ACS

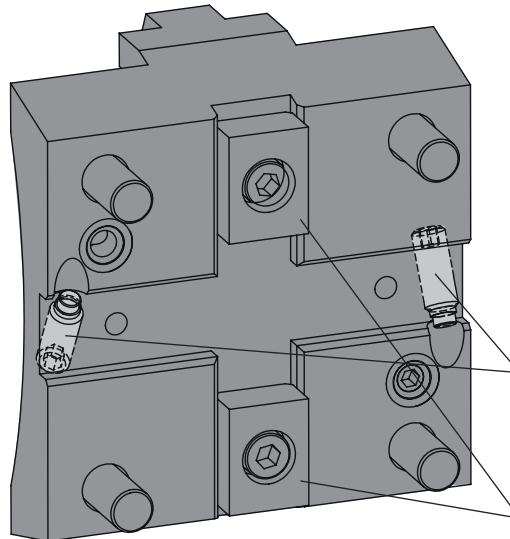

Höheneinstellung durch drehen des Gewindestiftes.

Height can be adjusted by turning the threaded pin.

Regolazione in altezza ruotando il grano.

Nutensteine sind bei der Auslieferung der Direktaufnahme gemäß Abbildung montiert.

T-slot fixture are mounted according to drawing.

Viti di fissaggio, montati come illustrato in figura.

Option 2: Höheneinstellbar über Maschinenachse / Option 2: Height adjustment via machine axis /

Opzione 2: regolazione dell' altezza tramite asse macchina utensile

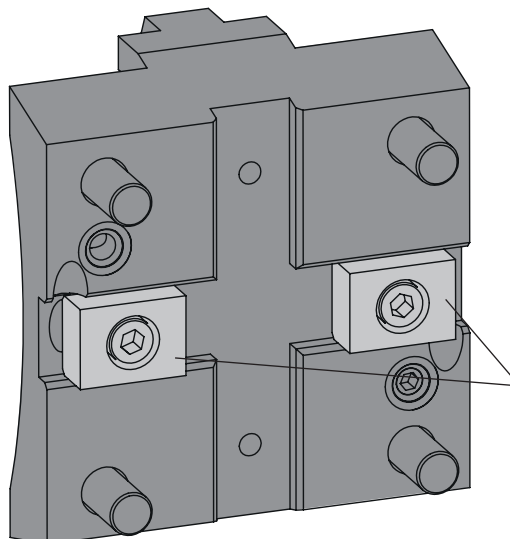

ARNO®

WERKZEUGE

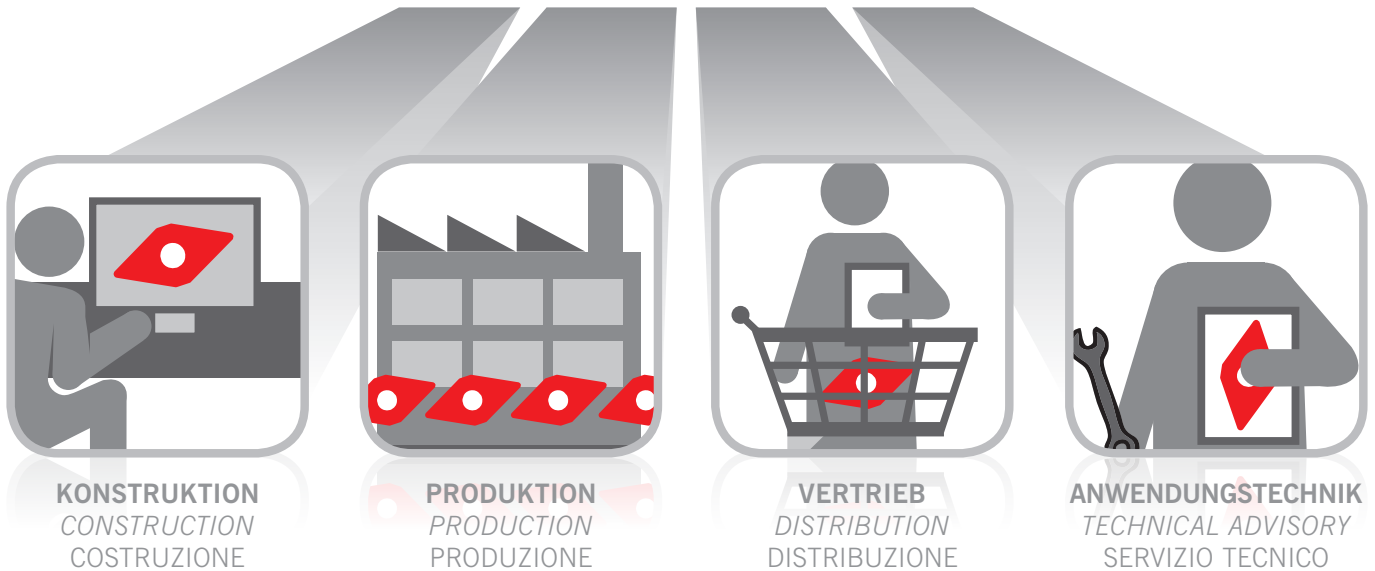

Schnell, flexibel und individuell.

Quick, flexible and individual.

Veloce, flessibile e individuale.

Konstruktion, Produktion und Vertrieb unter einem Dach.

Das ist die perfekte Verbindung um Ihnen Standard- und Sonderprodukte schnell und hochwertig anbieten zu können.

95% der Standardprodukte sind sofort verfügbar: Bei Bestellung bis 18 Uhr erhalten Sie Ihre Produkte bereits am nächsten Tag.

Mit großer fachlicher Kompetenz betreut Sie unser Außendienst-Team, unsere Anwendungstechniker helfen Ihnen mit Spezial-Wissen gerne auch vor Ort.

To have design, production and service all under one roof

is the perfect way of providing standard and special products.

95% of the standard programme is available from stock. Order received before 18.00 CET are dispatched the very same day and in most cases supplied next day.

Our competent team of technical sales engineers will be available to support you on site.

Costruzione, Produzione e Distribuzione sotto un unico tetto.

La sequenza perfetta per garantire un servizio di supporto cliente su prodotti Standard e Speciali di alta qualità.

Il 95% dei prodotti Standard sono disponibili a stock; con ordini entro le 18:00 garantiamo la consegna il giorno successivo.

Il nostro team di vendita altamente qualificato si offre come supporto alla produzione presso i nostri clienti direttamente sul territorio.

Weitere Informationen finden Sie unter:

For more information see:

Altre informazioni su:

www.arno.de

HDM – Montagehinweis / Assembly instructions / Schema di montaggio

Option 1 – linkes Modul: Kühlung mit ACS2 und zusätzlicher Jet-Düse / Option 1 – left module: Cooling with ACS2 and additional Jet Nozzle / Opzione 1 – modulo sinistro: Raffreddamento con ACS2 ed ugelli supplementari

Falls kein zusätzlicher Kühlmittelstrahl durch die montierte Kühlmitteldüse erwünscht ist, bitte den Gewindestift lösen und die Düse entfernen. Dann den beigelegten Verschlussstift mittig einsetzen und den Gewindestift wieder festziehen.

If no coolant is wanted from the fitted coolant jet, please loosen threaded pin and remove jet and replace with enclosed locking pin and then fasten the threaded pin.

Nel caso in cui l'ugello di refrigerante esterno non venisse utilizzato, rimuovere l'ugello e chiudere il passaggio esterno con il tappo a tenuta dato in dotazione.

Hier am Beispiel: HDM-N.-BMT-SDS-ACS /
Example: HDM-N.-BMT-SDS-ACS /
Esempio: HDM-N.-BMT-SDS-ACS

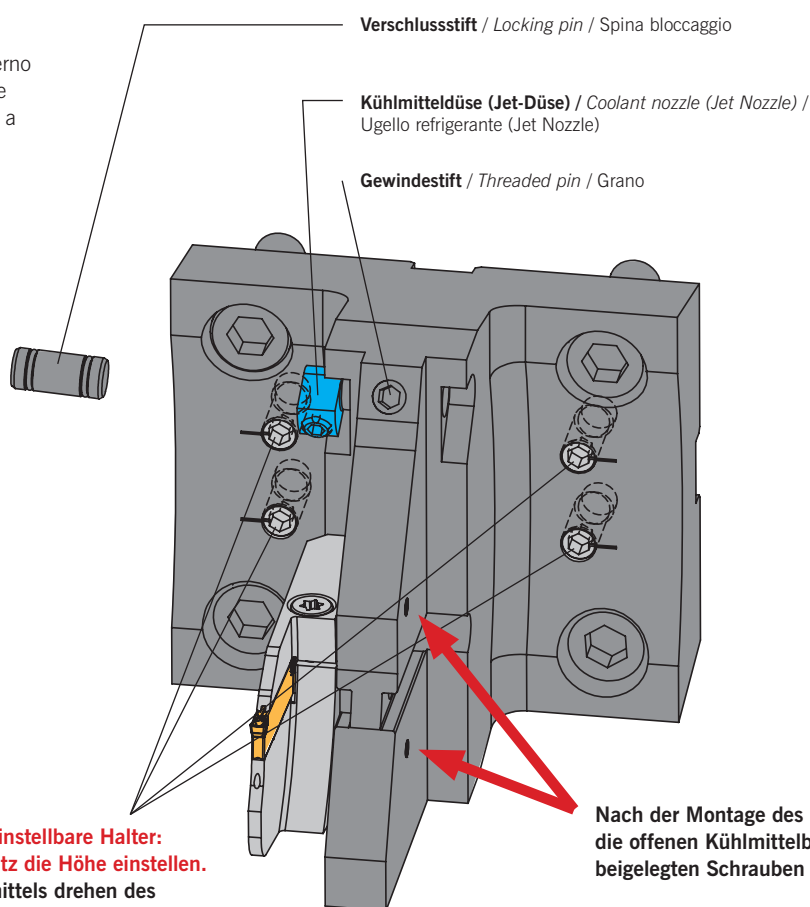

Verschlussstift / Locking pin / Spina bloccaggio

Kühlmitteldüse (Jet-Düse) / Coolant nozzle (Jet Nozzle) /
Ugello refrigerante (Jet Nozzle)

Gewindestift / Threaded pin / Grano

Hinweis für höhenstellbare Halter:
Bitte vor dem Einsatz die Höhe einstellen.
Höheneinstellung mittels drehen des Gewindestiftes. Danach Spanschrauben wieder anziehen.

When using height-adjustable holders:
Please adjust the height before use.
Height can be adjusted by turning the threaded pin. Re-tighten the clamping screws.

Nota: per supporti regolabili in altezza,
regolare l'altezza prima dell'uso.
Regolazione in altezza ruotando il grano.
Stringere le viti di serraggio.

Nach der Montage des Moduls bitte die offenen Kühlmittelbohrungen mit den beigelegten Schrauben verschließen.

After mounting the module, close the open coolant holes with the enclosed screws.

Nach der Montage des Moduls bitte die offenen Kühlmittelbohrungen mit den beigelegten Schrauben verschließen.

HDM – Montagehinweis / Assembly instructions / Schema di montaggio

Option 2 – rechtes Modul: Kühlung mit ACS2 und zusätzlicher Jet-Düse / Option 2 – right module:

Cooling with ACS2 and additional Jet Nozzle / Opzione 2 – modulo destro: Raffreddamento con ACS2 ed ugelli supplementari

Falls kein zusätzlicher Kühlmittelstrahl durch die montierte Kühlmitteldüse erwünscht ist, bitte den Gewindestift lösen und die Düse entfernen. Dann den beigelegten Verschlussstift mittig einsetzen und den Gewindestift wieder festziehen.

If no coolant is wanted from the fitted coolant jet, please loosen threaded pin and remove jet and replace with enclosed locking pin and then fasten the threaded pin.

Nel caso in cui l'ugello di refrigerante esterno non venisse utilizzato, rimuovere l'ugello e chiudere il passaggio esterno con il tappo a tenuta dato in dotazione.

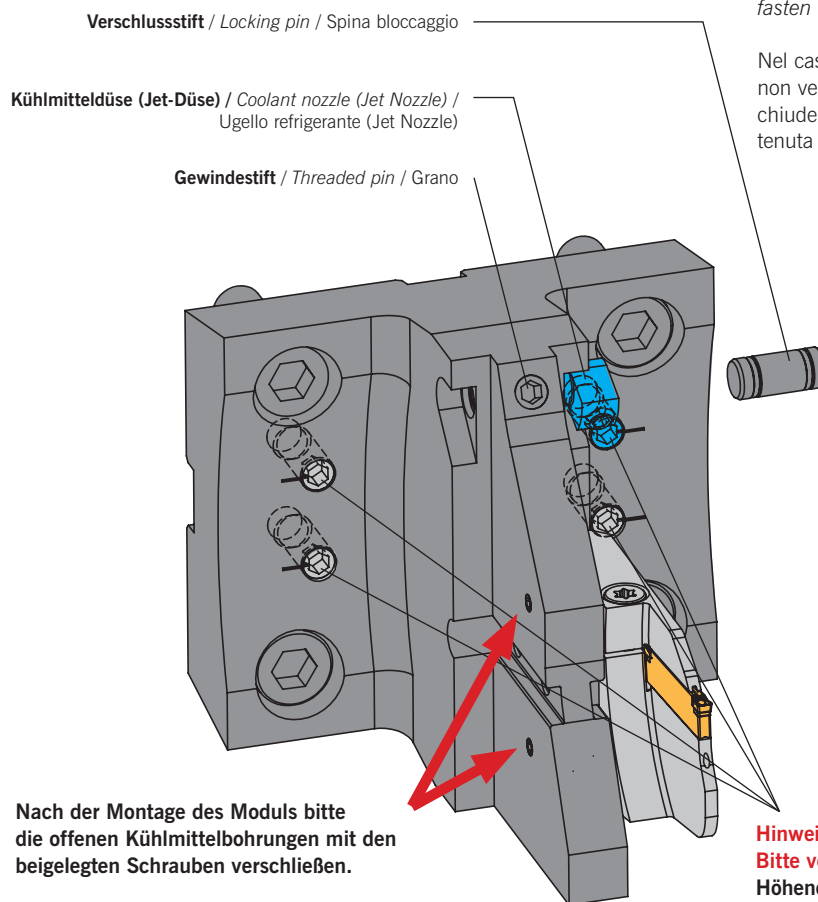

Nach der Montage des Moduls bitte die offenen Kühlmittelbohrungen mit den beigelegten Schrauben verschließen.

After mounting the module, close the open coolant holes with the enclosed screws.

Nach der Montage des Moduls bitte die offenen Kühlmittelbohrungen mit den beigelegten Schrauben verschließen.

Hinweis für höhenstellbare Halter: Bitte vor dem Einsatz die Höhe einstellen. Höheneinstellung mittels drehen des Gewindestiftes. Danach Spannschrauben wieder anziehen.

When using height-adjustable holders: Please adjust the height before use. Height can be adjusted by turning the threaded pin. Re-tighten the clamping screws.

Nota: per supporti regolabili in altezza, regolare l'altezza prima dell'uso. Regolazione in altezza ruotando il grano. Stringere le viti di serraggio.

M9A 0001 – Montagehinweis / Assembly instructions / Schema di montaggio

Option 1: linkes Modul / left module / modulo sinistro

Falls kein zusätzlicher Kühlmittelstrahl durch die montierte Kühlmitteldüse erwünscht ist, bitte den Gewindestift lösen und die Düse entnehmen. Dann den beigelegten Verschlussstift mittig einsetzen und den Gewindestift wieder festziehen.

If no coolant is wanted from the fitted coolant jet, please loosen threaded pin and remove jet and replace with enclosed locking pin and then fasten the threaded pin.

Nel caso in cui l'ugello di refrigerante esterno non venisse utilizzato, rimuovere l'ugello e chiudere il passaggio esterno con il tappo a tenuta dato in dotazione.

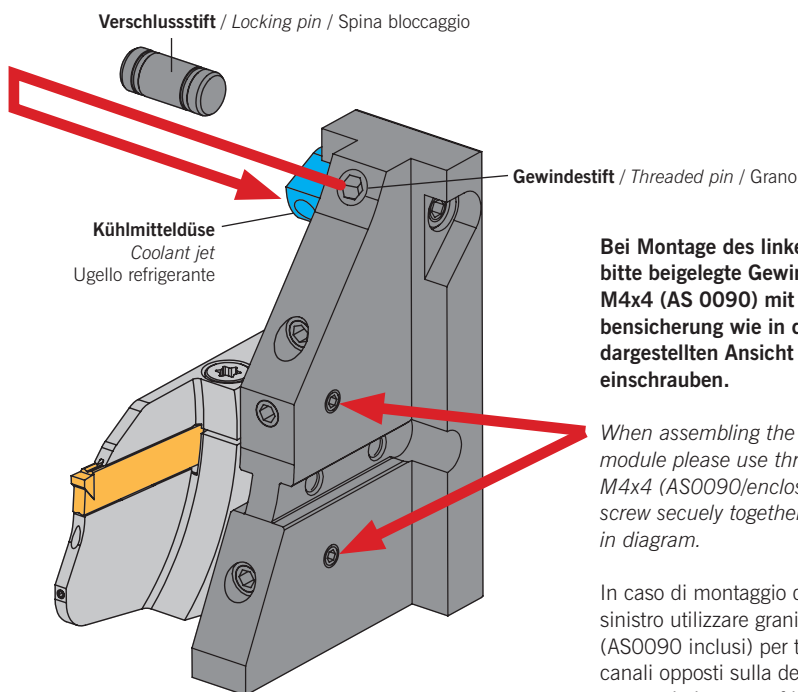

Bei Montage des linken Moduls bitte beigelegte Gewindestifte M4x4 (AS 0090) mit Schraubensicherung wie in der oben dargestellten Ansicht bündig einschrauben.

When assembling the left module please use threaded pins M4x4 (AS0090/enclosed) to screw securely together as shown in diagram.

In caso di montaggio del modulo sinistro utilizzare grani M4x4 (AS0090 inclusi) per tappare i canali opposti sulla destra di passaggio interno refrigerante.

Option 2: rechtes Modul / right module / modulo destro

Falls kein zusätzlicher Kühlmittelstrahl durch die montierte Kühlmitteldüse erwünscht ist, bitte den Gewindestift lösen und die Düse entnehmen. Dann den beigelegten Verschlussstift mittig einsetzen und den Gewindestift wieder festziehen.

If no coolant is wanted from the fitted coolant jet, please loosen threaded pin and remove jet and replace with enclosed locking pin and then fasten the threaded pin.

Nel caso in cui l'ugello di refrigerante esterno non venisse utilizzato, rimuovere l'ugello e chiudere il passaggio esterno con il tappo a tenuta dato in dotazione.

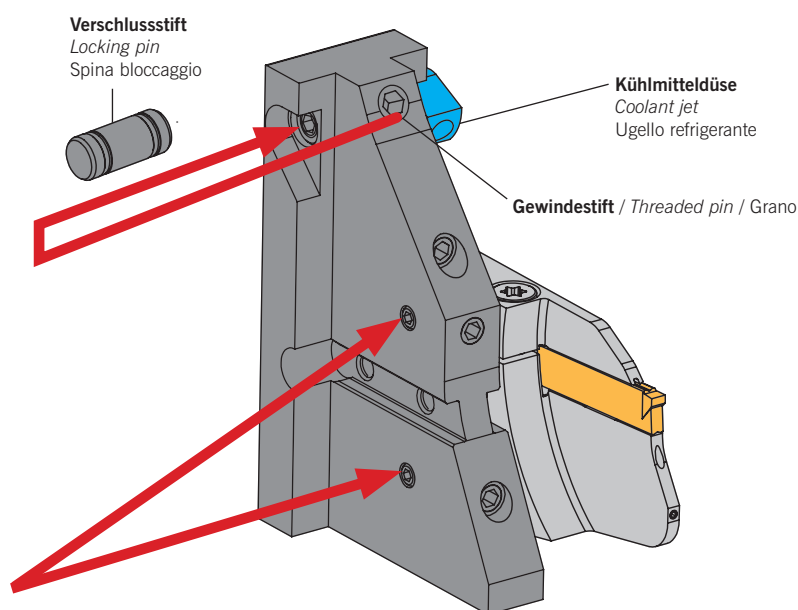

Bei Montage des rechten Moduls bitte beigelegte Gewindestifte M4x4 (AS 0090) mit Schraubensicherung wie in der oben dargestellten Ansicht bündig einschrauben.

When assembling the right module please use threaded pins M4x4 (AS0090/enclosed) to screw securely together as shown in diagram.

In caso di montaggio del modulo destro utilizzare grani M4x4 (AS0090 inclusi) per tappare i canali opposti sulla sinistra di passaggio interno refrigerante.

M9A 0002 – Montagehinweis / Assembly instructions / Schema di montaggio

Option 1: linkes Modul / left module / modulo sinistro

Falls kein zusätzlicher Kühlmittelstrahl durch die montierte Kühlmitteldüse erwünscht ist, bitte die Klemmschraube lösen und die Düse entnehmen. Dann den beigelegten Verschlussstift bündig einsetzen und die Schraube wieder festziehen.

If no coolant is wanted from the fitted coolant jet, please loosen threaded pin and remove jet and replace with enclosed locking pin and then fasten the threaded pin.

Nel caso in cui l'ugello di refrigerante esterno non venisse utilizzato, rimuovere l'ugello e chiudere il passaggio esterno con il tappo a tenuta dato in dotazione.

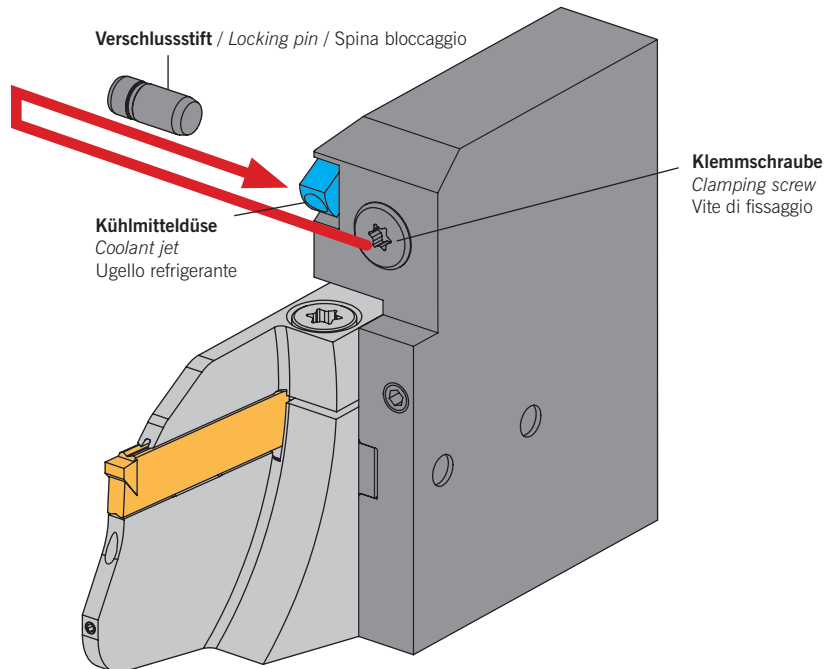

Option 2: rechtes Modul / right module / modulo destro

Falls kein zusätzlicher Kühlmittelstrahl durch die montierte Kühlmitteldüse erwünscht ist, bitte die Klemmschraube lösen und die Düse entnehmen. Dann den beigelegten Verschlussstift bündig einsetzen und die Schraube wieder festziehen.

If no coolant is wanted from the fitted coolant jet, please loosen threaded pin and remove jet and replace with enclosed locking pin and then fasten the threaded pin.

Nel caso in cui l'ugello di refrigerante esterno non venisse utilizzato, rimuovere l'ugello e chiudere il passaggio esterno con il tappo a tenuta dato in dotazione.

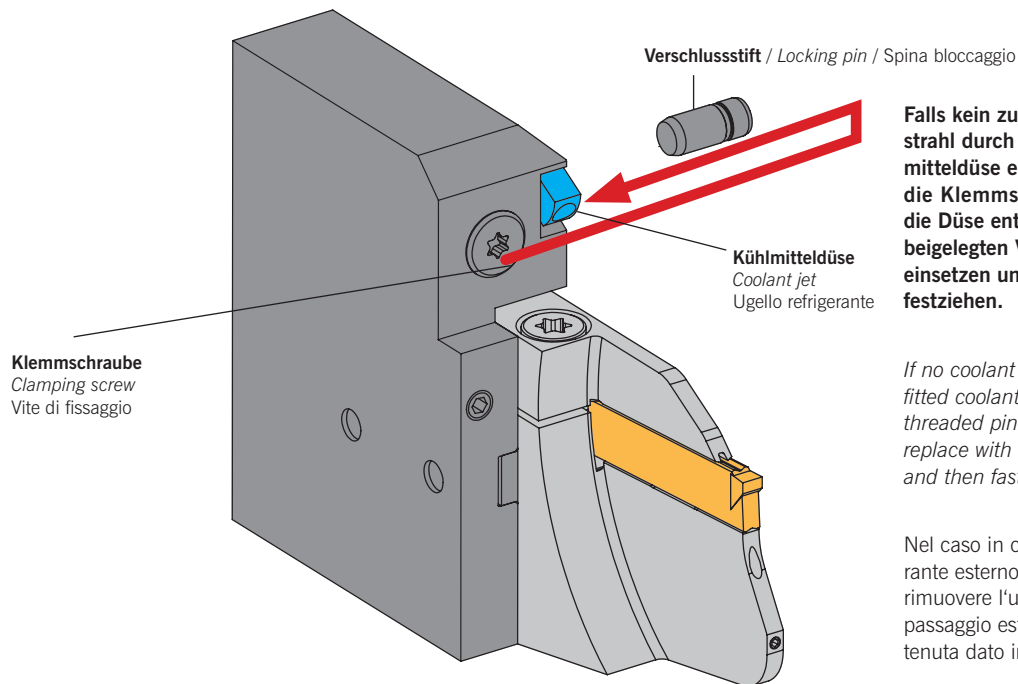

M9A 0003 – Montagehinweis / Assembly instructions / Schema di montaggio

Option 1: linkes Modul / left module / modulo sinistro

Falls kein zusätzlicher Kühlmittelstrahl durch die montierte Kühlmitteldüse erwünscht ist, bitte den Gewindestift lösen und die Düse entnehmen. Dann den beigelegten Verschlussstift mittig einsetzen und den Gewindestift wieder festziehen.

If no coolant is wanted from the fitted coolant jet, please loosen threaded pin and remove jet and replace with enclosed locking pin and then fasten the threaded pin.

Nel caso in cui l'ugello di refrigerante esterno non venisse utilizzato, rimuovere l'ugello e chiudere il passaggio esterno con il tappo a tenuta dato in dotazione.

Hinweis für höhenverstellbare Halter:
Bitte vor dem Einsatz die Höhe einstellen und danach die Spanschrauben wieder anziehen.

*When using height-adjustable holders:
Adjust the height before use and then re-tighten the clamping screws.*

Nota: per supporti regolabili in altezza:
Regolare l'altezza prima dell'uso e poi stringere le viti di serraggio.

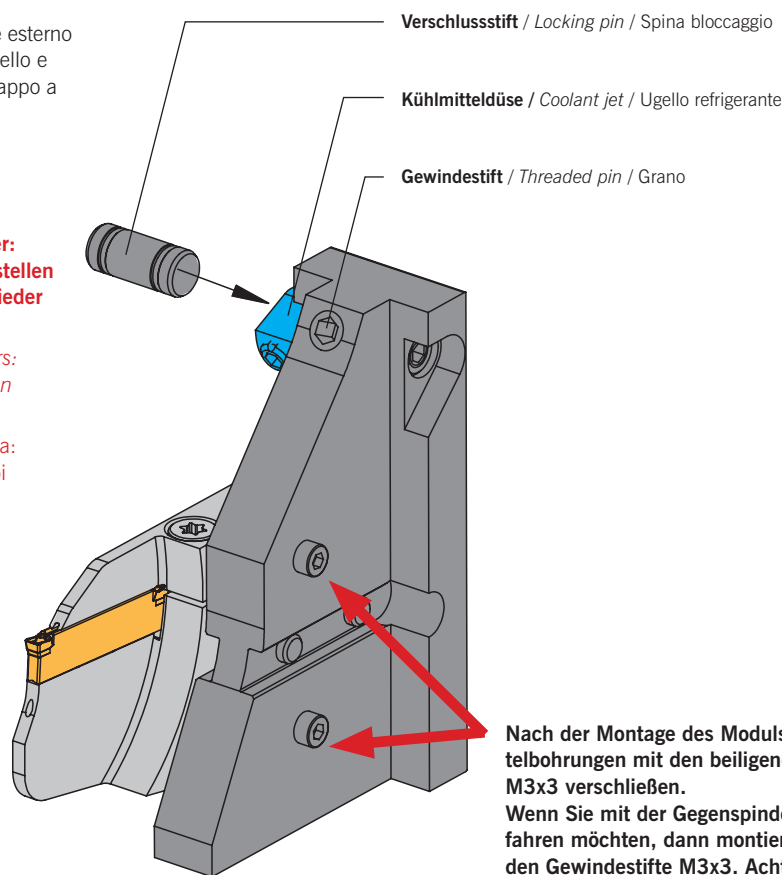

Nach der Montage des Moduls bitte die offenen Kühlmittelbohrungen mit den beiliegenden Zylinderschrauben M3x3 verschließen.
Wenn Sie mit der Gegenspindel noch dichter herangefahren möchten, dann montieren Sie bitte die beiliegenden Gewindestifte M3x3. Achten Sie bitte darauf, dass die Stifte nur bündig eingedreht werden, da sonst die Kühlmittelversorgung für das Modul unterbrochen wird.

*After mounting the module, close the open coolant holes with the enclosed M3x3 screws.
If you want to move closer to the counter spindle, please use the enclosed M3x3 threaded pins. Please ensure that the pins are flush mounted, otherwise the coolant supply for the module will be interrupted.*

Dopo aver montato il modulo, chiudere i fori di refrigerazione aperti con le M3x3 viti incluse.
Se si desidera avvicinarsi al mandrino, utilizzare i grani filettati M3x3 inclusi. Assicurarsi che i perni siano montati a filo, in caso contrario l'alimentazione del refrigerante del modulo sarà interrotta.

M9A 0003 – Montagehinweis / Assembly instructions / Schema di montaggio

Option 2: rechtes Modul / right module / modulo destro

Falls kein zusätzlicher Kühlmittelstrahl durch die montierte Kühlmitteldüse erwünscht ist, bitte den Gewindestift lösen und die Düse entnehmen. Dann den beigelegten Verschlussstift mittig einsetzen und den Gewindestift wieder festziehen.

If no coolant is wanted from the fitted coolant jet, please loosen threaded pin and remove jet and replace with enclosed locking pin and then fasten the threaded pin.

Nel caso in cui l'ugello di refrigerante esterno non venisse utilizzato, rimuovere l'ugello e chiudere il passaggio esterno con il tappo a tenuta dato in dotazione.

Hinweis für höheninstellbare Halter:
Bitte vor dem Einsatz die Höhe einstellen und danach die Spannschrauben wieder anziehen.

When using height-adjustable holders: Adjust the height before use and then re-tighten the clamping screws.

Nota: per supporti regolabili in altezza: Regolare l'altezza prima dell'uso e poi stringere le viti di serraggio.

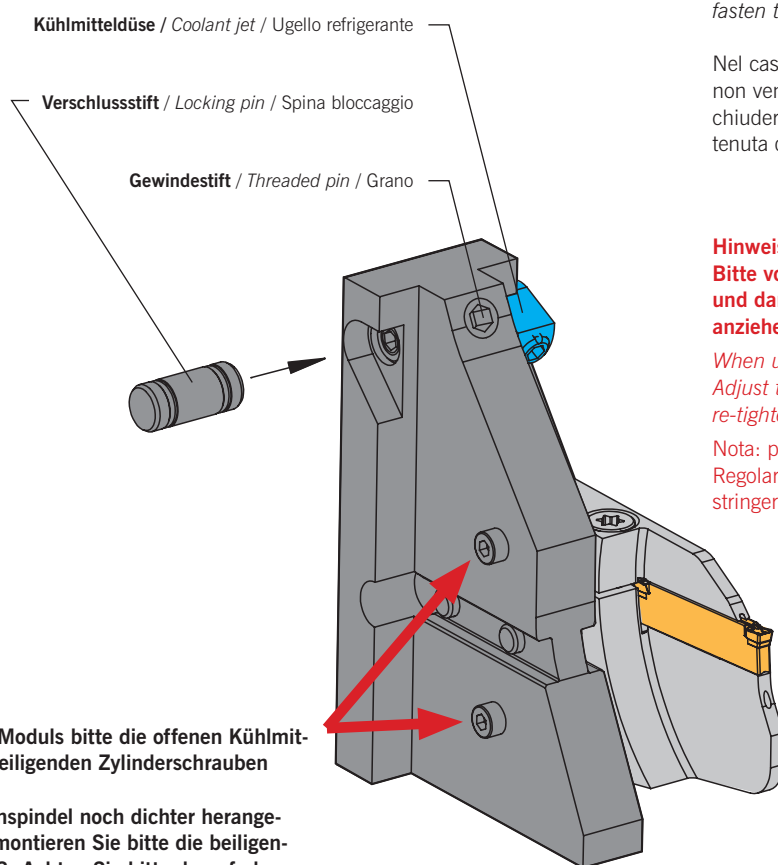

Nach der Montage des Moduls bitte die offenen Kühlmittelbohrungen mit den beiliegenden Zylinderschrauben M3x3 verschließen.

Wenn Sie mit der Gegenspindel noch dichter herangehen möchten, dann montieren Sie bitte die beiliegenden Gewindestifte M3x3. Achten Sie bitte darauf, dass die Stifte nur bündig eingedreht werden, da sonst die Kühlmittelversorgung für das Modul unterbrochen wird.

After mounting the module, close the open coolant holes with the enclosed M3x3 screws.

If you want to move closer to the counter spindle, please use the enclosed M3x3 threaded pins. Please ensure that the pins are flush mounted, otherwise the coolant supply for the module will be interrupted.

Dopo aver montato il modulo, chiudere i fori di refrigerazione aperti con le M3x3 viti incluse.

Se si desidera avvicinarsi al mandrino, utilizzare i grani filettati M3x3 inclusi. Assicurarsi che i perni siano montati a filo, in caso contrario l'alimentazione del refrigerante del modulo sarà interrotta.

M9A 0004 – Montagehinweis / Assembly instructions / Schema di montaggio

Option 1: Höhereinstellbar / Height-adjustable / Regolabili in altezza

Hinweis für höhereinstellbare Halter:
Bitte vor dem Einsatz die Höhe einstellen.

When using height-adjustable holders:
Please adjust the height before use.

Nota: per supporti regolabili in altezza,
regolare l'altezza prima dell'uso.

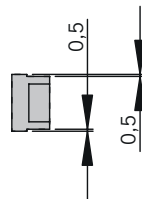
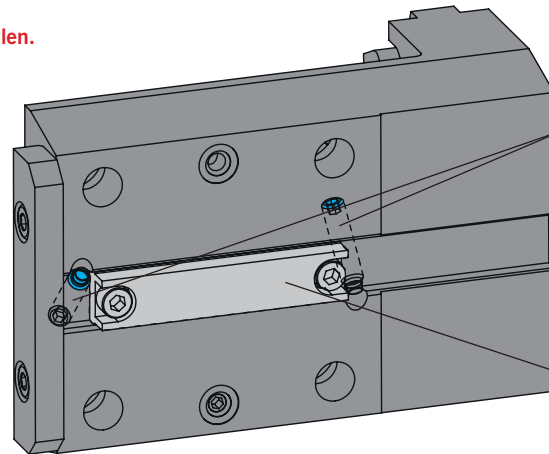

Höhereinstellung kann mittels drehen der
Gewindestifte im Bereich $\pm 0,5$ mm über die
2 Gewindestifte erfolgen.

The height can be manually adjusted in the
range of $+ - 0.5$ mm through the two pins.

La regolazione manuale è possibile in un range
di $\pm 0,5$ mm tramite le 2 viti.

Nutenstein NS 15/14x10x69 ist bei der
Auslieferung der Direktaufnahme bereits
montiert.

T-slot fixture NS 15 / 14x10x69 is already
mounted. The height can be manually adjusted
in the range of $+ - 0.5$ mm through the
two pins.

Pattino NS 15 / 14x10x69 già montato. La
regolazione manuale è possibile in un range
di $\pm 0,5$ mm tramite le 2 viti.

Option 2: Höhereinstellbar über Maschinenachse / Height is adjusted via machine axis /

Regolazione dell'altezza è possibile tramite macchina

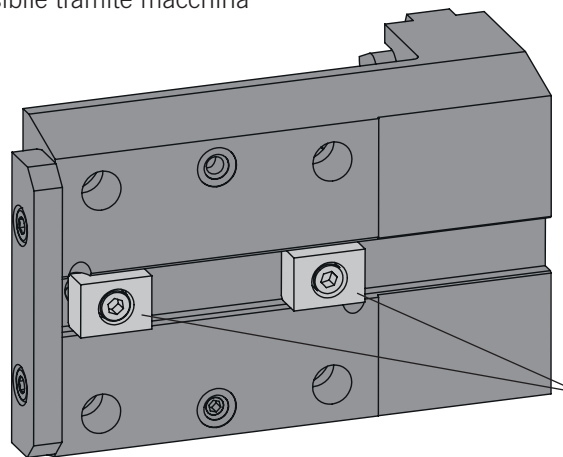

Sofern die Höhereinstellung über die Ma-
schinenachse kompensiert werden kann bitte
alternativ die 2 Nutensteine NS 20x9,7x15
montieren.

If the height is adjusted via machine axis,
the two t-slot fixtures NS 20x9,7x15 can be
mounted as shown.

Se la regolazione dell'altezza è possibile tramite
macchina, è possibile montare i pattini NS
20x9,7x15 come in figura.

M9A 0005 – Montagehinweis / Assembly instructions / Schema di montaggio

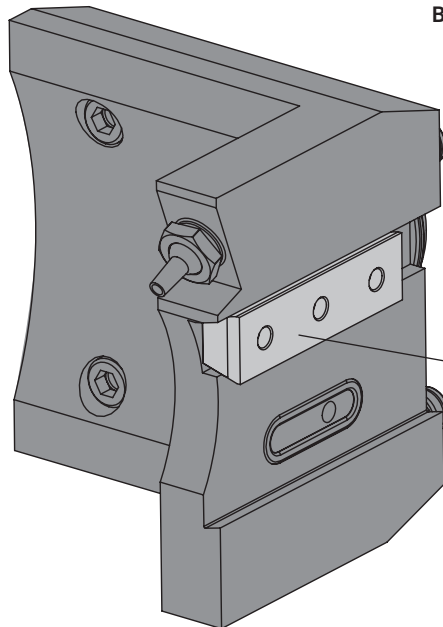

Breite Klemmleiste / Wide clamping strip / Staffa larga di bloccaggio

Die breite Klemmleiste 60AB3444 ist bei Auslieferung der Direktaufnahme bereits montiert. Die manuelle Höheneinstellung findet außerhalb der Maschine statt.

The wide clamping strip 60AB3444 is already mounted. Manual height adjustment takes place outside the machine.

La staffa larga 60AB3444 già montata. La regolazione manuale avviene al di fuori della macchina.

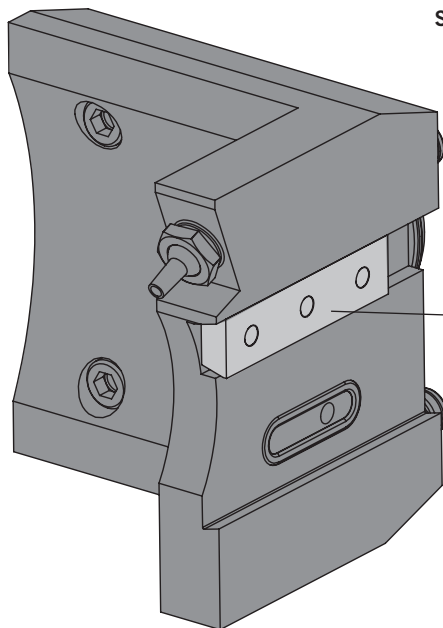

Schmale Klemmleiste / Thin clamping strip / Staffa stretta di bloccaggio

Die schmale Klemmleiste W67310.0624 bitte bei schmäleren Klingen einsetzen. Die manuelle Höheneinstellung findet außerhalb der Maschine statt.

Use the W67310.0624 thin clamping strip for thin blades. Manual height adjustment takes place outside the machine.

Utilizzare la staffa stretta di bloccaggio W67310.0624 per le lame sottili. La regolazione manuale avviene al di fuori della macchina.

M9A 0006 – Montagehinweis / Assembly instructions / Schema di montaggio

Um bei rechten MS Aufnahmen die Schneidplatte von der Gegenseite (wie abgebildet) zu spannen, muss alternativ die Schraube AS 0050D verwendet werden.
(doppelseitig IP20 Schnittstelle)

Dabei gilt folgendes:
nach links drehen = spannen
nach rechts drehen = lösen

In order to be able to mount the insert from the opposite side (as shown), alternatively the screw AS 0050D should be used (Double-sided IP20 interface)

*Please note:
Turn left = clamping
Turn right = open*

Per essere in grado di montare l'inserto dal lato opposto (come mostrato), in alternativa va utilizzata la vite AS 0050D (IP20)

ATTENZIONE:
Rotazione a sinistra = chiude
Rotazione a destra = apre

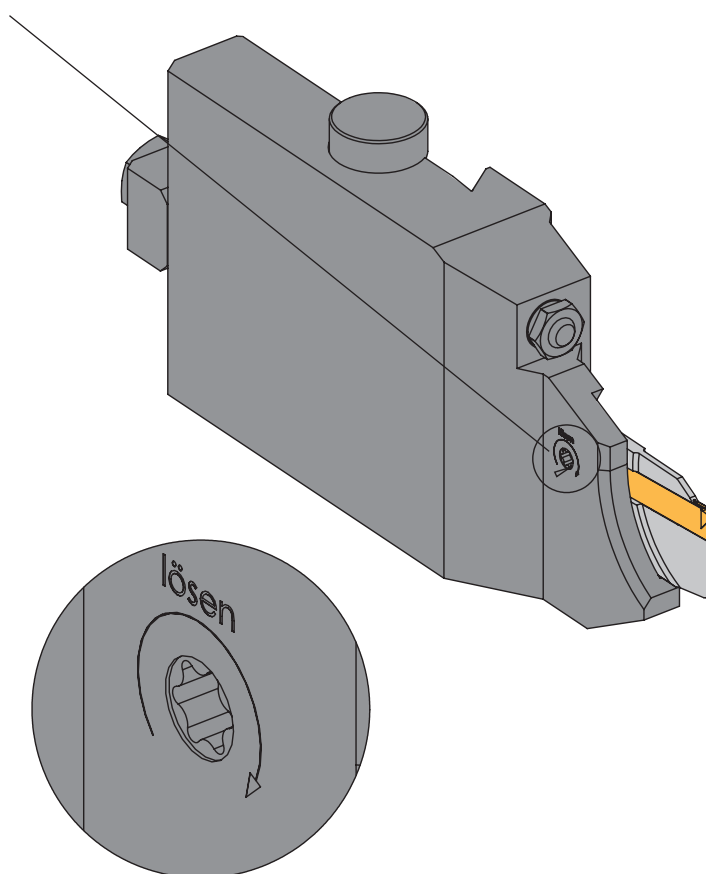

M9A 0007 – Montagehinweis / Assembly instructions / Schema di montaggio

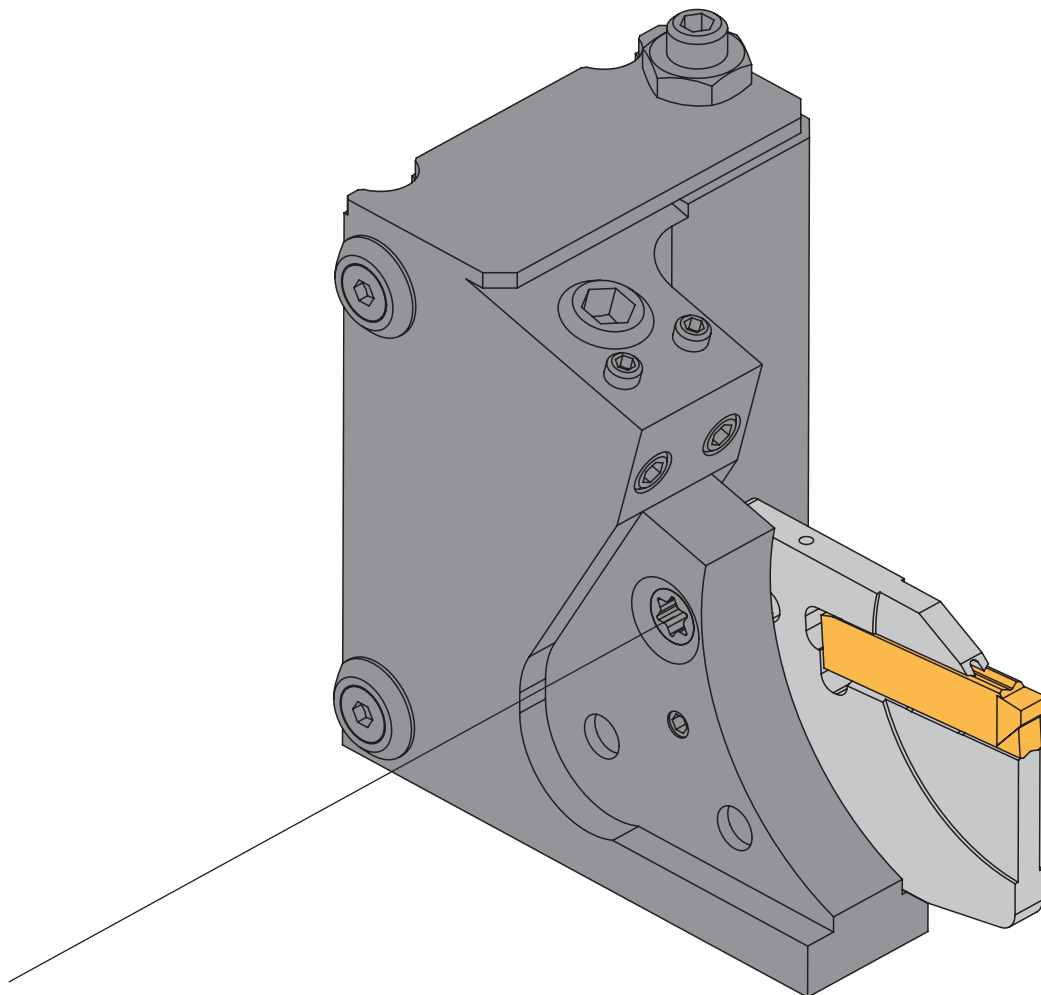

Um bei rechten MS Aufnahmen die Schneidplatte von der Gegenseite (wie abgebildet) zu spannen, muss alternativ die Schraube AS 0050D verwendet werden. (doppelseitig IP20 Schnittstelle)

Dabei gilt folgendes:

nach links drehen = spannen

nach rechts drehen = lösen

In order to be able to mount the insert from the opposite side (as shown), alternatively the screw AS 0050D should be used (Double-sided IP20 interface)

Please note:

Turn left = clamping

Turn right = open

Per essere in grado di montare l'inserto dal lato opposto (come mostrato), in alternativa va utilizzata la vite AS 0050D (IP20)

ATTENZIONE:

Rotazione a sinistra = chiude

Rotazione a destra = apre

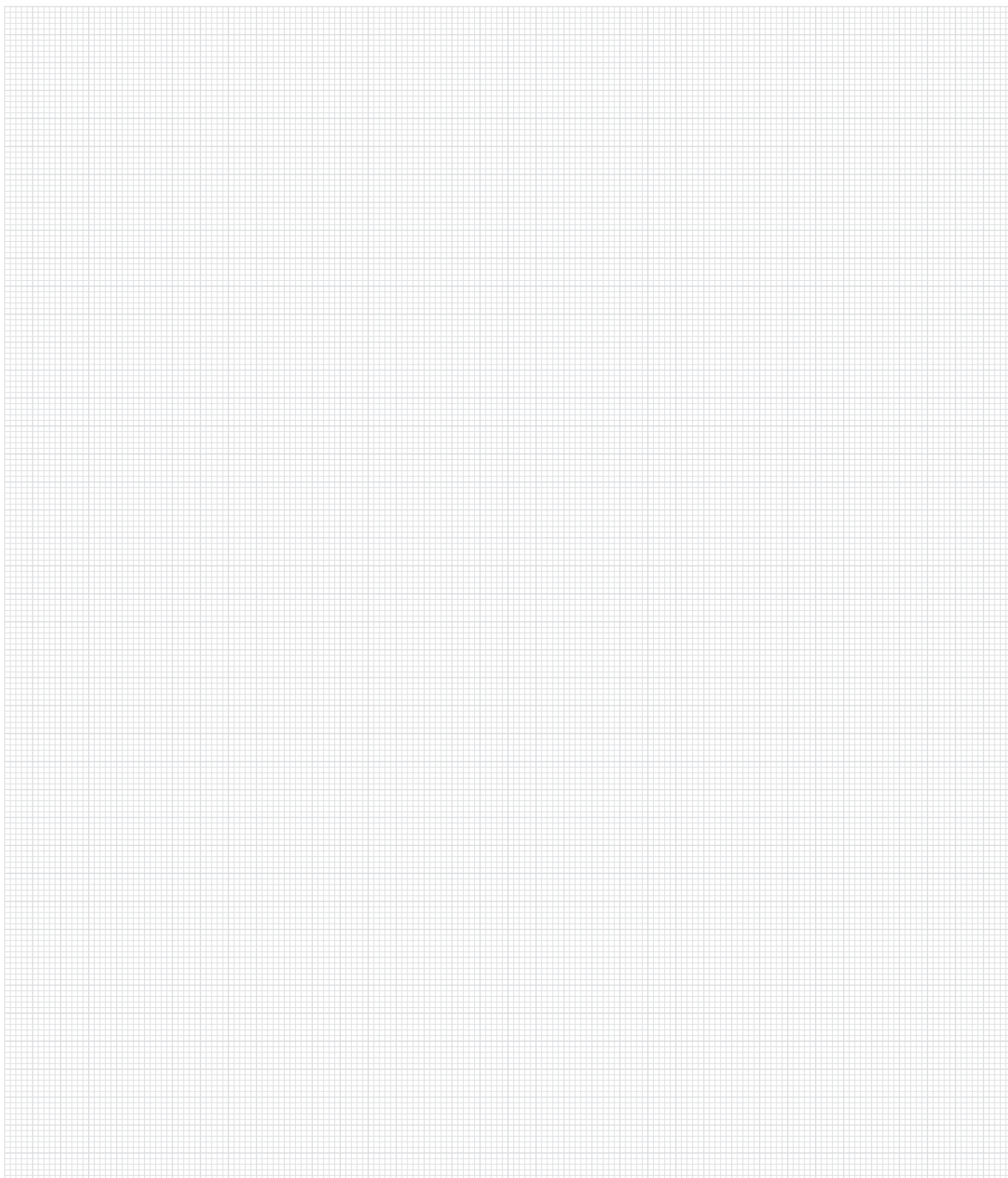

ARNO[®]
WERKZEUGE

Weitere Informationen finden Sie unter:

For more information see:

Per maggiori informazioni visita il sito:

www.arno.de

INFORMATIONEN

INFORMATION

INFORMAZIONI



Informationen

- Vergleichstabellen
- Härtevergleich
- Verschleiß und Abhilfe
- Anwendungshinweise

Information

- *Material – Cross reference*
- *Hardness – comparison table*
- *Wear and its solution*
- *Application reference*

Informazioni

- Tabelle comparative
- Usura e soluzioni
- Comparazione delle durezze
- Suggerimenti tecnici

604 – 619

620 – 621

622 – 623

624 – 632



Werkstoff-Vergleichstabelle

Material – comparison table

Tavola comparativa dei materiali

ISO	Zerspanungs- gruppe	Deutschland Germany Germania W.-Nr. DIN	Deutschland Germany Germania W.-Nr. DIN EN	Deutschland Germany Germania DIN	Deutschland Germany Germania DIN EN	Deutschland – Herstellerbezeichnung Germany – Manufacturer's designation Germania – identificazione del produttore	Großbritannien Great Britain Gran Bretagna B.S.	Großbritannien Great Britain Gran Bretagna EN
Bau- und Konstruktionsstähle / Structural and constructional steels / Acciai da costruzione								
P	P1	1.0401		C 15	C15		080M15, 144917CS, 040A15, 080A15	
	P1	1.0402		C 22	C22		040 A 15, 055 M 15, En 2, 22 CS, 22 HS, C 22, 070 M 20	2D, 2
	P2	1.0501		C 35	C35		080A32, 080A35, 080M36, 1449.40CS	
	P2	1.0503		C 45	C45		060A47, 080M46, 1449.50HS, 1449.50CS	
	P4	1.0535		C 55	C55		070M55, 5770-50	9
	P4 / P5	1.0601		C 60	C60		060A62, 5770-60, 1449 60HS.CS	
	P6	1.0715		9 SMn 28	11SMn30		230M07	
	P6	1.0718		9 SMnPb 28	11SMnPb30			
	P6	1.0722		10 SPb 20	10SPb20			
	P6	1.0726		35 S 20	35S20		212M36	
	P6	1.0736		9 SMn 36	11SMn37		240M07	1B
	P6	1.0737		9 SMnPb 36	11SMnPb37	Ledloy		
	P7 / P10	1.0904				55Si7	250A53	45
	P7 / P10	1.0961		60 SiCr 7	S340MGC, 60SiCr7		250A61	
	P1	1.1141		Ck 15	C15E		040A15, 080M15, S14, CS17	32C
	P7 / H2	1.1157		40 Mn 4	40Mn4		150M36	15
	P1 / P3	1.1158		Ck 25	C25E		070M26	
	P7	1.1167		36 Mn 5	36Mn5		150M36	15 B
	P7	1.1170		28 Mn 6	28Mn6		150M28, 150M19, S92	14A, 14B
	P2	1.1183		Cf 35	C35G		060A35, 080A35	
	P2	1.1191		Ck 45	C45E		080M46, 060A47	
	P4 / P5	1.1203		Ck 55	C55E		060A57	9
	P2 / P3	1.1213		Cf 53	C53G		060A52, 070M55	
	P4 / P5	1.1221		Ck 60	C60E		060A62, 070M60, CS60	
	P4 / H1	1.1274		Ck 101	C101E, C100S		060A96, 5770-95, CS95	
	P11	1.3401		X 120 Mn 12	X120Mn12			
	P7 / H2	1.3505		100 Cr 6	100Cr6		BL3, 534A99, 535A99, 2S135, S135	
	P7	1.5415		15 Mo 3	16Mo3		1501-240, 1503-243B, 3606-243, 3059-243	
	P3	1.5423		16 Mo 5	16Mo5		1503-245-420	

Werkstoff-Vergleichstabelle

Material – comparison table

Tavola comparativa dei materiali

ISO	Frankreich France Francia AFNOR	Italien Italy Italia UNI	Schweden Sweden Svezia SS	Spanien Spain Spagna UNE	Japan Japan Giappone JIS	USA USA USA AISI/SAE/ASTM	Belgien Belgium Belgio NBN	Russland Russia Russia GOST
Bau- und Konstruktionsstähle / Structural and constructional steels / Acciai da costruzione								
P	C18RR, XC18	C15, C16, 1C15	1350	F.111	S 15 C, JIS S 15C	J 409 Grade 1015		
	AF42C20, XC25, 1C22	C20, C21	1450	1C22, F112	S 20 C, S22C, JIS S 20C		C25-1	20
	C35, 1C35, AF55C35	C35, 1C35	1572, 155	F.113	S 35 C		C35-1	35
	1C45, AF 65 C 45	C45, 1C45	1650	F.114	JIS S 45C		C45-1	45
	C54, 1C55, AF 70 C 55	C55, 1C55	1655	F.115	S 55 C		C55-1	55
	C60, 1C60, AF70C55	C60, 1C60		F.115	S 58 C		C60-1	60
	S250	CF9Mn28	1912	F.2111 - 11SMn28	JIS SUM22			
	S250Pb	CF9SMnPb28	1914	F.2112 - 11SMn-Pb28	SUM22L, SUM23L, SUM24L	12L13, 12L14, J 403 Grade 12L14, J 1397 Grade 12L14		
	35MF6		1957	F.210G		J 403 Grade 1141		
	S300	CF9SMn36		F.2113 - 12 SMn 35	SUM 25	J 403 Grade 1213, J 403 Grade 1215, J 1392 Grade 1213		
	S300Pb	CF9SMnPb36	1926	F.2114 - 12 SMnPb 35		J 403 Grade 12L14, J 1397 Grade 12L14		
	55S7		2085	F.1440 - 56 Si 7				
	60SC7			F.1442 - 60 SiCr 8				
			1370	F.1511 - C 16 k, F.1110 - C 15 k	S 15, S 15 CK, JIS S 15 C		C16-2	15
	35M5					1035, 1041		40G
	2C25			F.1120 - C 25 k, C25K (F1120)	S 25 C, S 28 C		C25-2	25
	40M5		2120	F.1203 - 36 Mn5	SMn 438 (H), SCMn 3			35G2
	20M5	C28Mn		28Mn6	SCMn1	1027	28Mn6	30G
	XC38H1TS	C36, C38			S 35 C		C36	35
	C45RR, XC42H1, XC45, 2C45, XC48, XC48H1		1672	F1140-C45k, F1142-C48k	S 45 C, S 48 C		C45-2	45
	XC55H1, 2C55, XC54		1655	F.1150 - C 55 k	S 55 C		C55-2	55
	XC48H1TS				S 50 C	1050, 1055	C53	50
	C60RR, XC60, 2C60		1665, 168	F.511, F.512	S 58 C		C60-2	60
	C100RR, C100, XC100, E 100		1870		SUP4			
	Z120M12, Z120Mn12		2183	F.82551-AM-X 120, Mn 12	SCMnH1, SCMnH11			110G13L
	Y100C6, 100C6, 100Cr6	100Cr6	2258	F.5230 100 Cr6, F.1310-100 Cr 6, F.131	SUJ 2, SUJ 4	L3		SchCh15
	15D3, 15Mo3	16Mo3 (KG KW)	2912	F.2601-16 Mo 3			16Mo3	
	16Mo5KG, 16Mo5KW		F.2602-16Mo5	SB 450 M, SB 480 M		16Mo5		



Werkstoff-Vergleichstabelle

Material – comparison table

Tavola comparativa dei materiali

ISO	Zerspanungs- gruppe	Deutschland Germany Germania W.-Nr. DIN	Deutschland Germany Germania W.-Nr. DIN EN	Deutschland Germany Germania DIN	Deutschland Germany Germania DIN EN	Deutschland – Herstellerbezeichnung Germany – Manufacturer's designation Germania – identificazione del produttore	Großbritannien Great Britain Gran Bretagna B.S.	Großbritannien Great Britain Gran Bretagna EN
Bau- und Konstruktionsstähle / Structural and constructional steels / Acciai da costruzione								
P	P7	1.5622		14 Ni 6	14Ni6			
	P11	1.5662		X 8 Ni 9	X8Ni9		1501-509,510, 3603-509LT, 1502-502-650, 509-690, 1503-509-690	
	P11	1.5680		12 Ni 19	X12Ni5, 12Ni19			
	P9	1.5710		36 NiCr 6	36NiCr6		640A35	
	P7	1.5732		14 NiCr 10	14NiCr10			
	P7	1.5752		14 NiCr 14	15NiCr13		655M13, 655A12, 655H13	36A, 36B
	P7 / P9	1.6511		36 CrNiMo 4	36CrNiMo4		816M40	110
	P7	1.6523		20NiCrMo2-2	21NiCrMo2		805H20, 805M20, 806M20	362
	P9	1.6546		40 NiCrMo 22	40NiCrMo2-2, 40NiCrMo2KD		311-Type7	
	P7 / P9	1.6582		34 CrNiMo 6	34CrNiMo6		816M40, 817M40	24
	P7	1.6587		17 CrNiMo 8, 17 CrNiMo 6, 17 CrNiMo 6 BG	17CrNiMo6, 18CrNiMo7-6		820A16	
	P7	1.6657		14 NiCrMo 134	14NiCrMo13-4		832H13, 832M13, S157	36C
	P7	1.7015		15 Cr 3	15Cr2KD		523M15	206
	P7 / P8	1.7033		34 Cr 4	34Cr4		530A32, 530H32, 530M32	
	P7 / P9	1.7035		41 Cr 4	41Cr4		530M40, 530A40, 530H40	18
	P9	1.7045		42 Cr 4	42Cr4		530A40	18
	P7	1.7131		16 MnCr 5	16MnCr5		527M17, 590H17, 590M17	
	P7 / P9	1.7176		55 Cr 3	55Cr3		525A58, 525A60, 525H60	48
	P8	1.7218		25 CrMo 4	25CrMo4		1717CDS110, 708A25	
	P7 / P9	1.7220		34 CrMo 4	34CrMo4		708A37	19B
P7 / P9	1.7223		41 CrMo 4	41CrMo4		708M40, 3111-5.1		
P7 / P9	1.7225		42 CrMo 4	42CrMo4		708A42, 708M40, 709M40	19A	
P7	1.7262		15 CrMo 5	15CrMo5				

Werkstoff-Vergleichstabelle

Material – comparison table

Tavola comparativa dei materiali

ISO	Frankreich France Francia AFNOR	Italien Italy Italia UNI	Schweden Sweden Svezia SS	Spanien Spain Spagna UNE	Japan Japan Giappone JIS	USA USA USA AISI/SAE/ASTM	Belgien Belgium Belgio NBN	Russland Russia Russia GOST
Bau- und Konstruktionsstähle / Structural and constructional steels / Acciai da costruzione								
P	16N6, 15N6, 15Ni6	14Ni6KG, 14Ni6KT		F.2641-15Ni6			18Ni6	
	Z8N9, 9Ni490	X10Ni9, X12Ni09		F.2645-X8 Ni09	SL9N53(60)		10Ni36	
	Z18N5, 5Ni390					2515, 2517	12Ni20	
	35NC6				SNC 236			
	14NC11	16NiCr11		F.1540-15NiCr11	SNC 415 (H)			
	14NC11, 12NC15, 14NC12, 13NiCr14				SNC 815 (H), SNC22, JIS SNC 815	3310, 3415, 9314	13NiCr12	
	40NCD3, 36CrNiMo4, 35NCD5	38NiCrMo7 (KB)		F.1280-35NiCrMo4				40ChN2MA
	20NCD2, 22NCD2	20NiCrMo2	2506	F1552-20NiCrMo2, F1534-20NiCrMo3	SNCM 220 (H)	J 1268 Grade 8620H		
	40NCD2	40NiCrMo2 (KB)		F1204-40NiCrMo2, F1205-40NiCr- Mo2DF	SNCM 240		40NiCrMo2	38ChGNM
	35NCD6, 34CrNiMo6, 34CrNiMo8	35NiCrMo6KB	2541	F1272-40NiCrMo7, 34CrNiMo6	SNCM 447, JIS Snc M447		35CrNiMo6	38Ch2N2MA
	18NCD6	18NiCrMo7		F.1560-14 NiCr- Mo13, F.156			17CrNiMo7	
	16NCD13	15NiCrMo13		F1560-14NiCrMo13, F.1569-14NiCr- Mo131			14NiCrMo13	
	12C3, 15Cr2, 18C3				SCr 415 (H)		15Cr2	15Ch
	32C4, 34C4	34Cr4(KB)		F.8221-35 Cr 4, F.224	SCr 435 (H)		34Cr4	35Ch
	42C4, 41Cr4	41Cr4, 41Cr4KB		38Cr4, 38Cr41, 42Cr4, F.1202-42Cr4	SCR4, Scr 440 (H)		41Cr4	40Ch
	42C4, 42C4TS	41Cr4	2245	F1201, F1202, F1206, F.1202-42Cr4	SCR4, Scr 440 (H), Scr 440	5140, 5140H		40Ch
	16MC5, 16MC4, 16MnCr5	16MnCr5	2511, 2173	F.1515-16 MnCr5, F.151		J 1268 Grade 4118H	16MnCr5	18ChG
	55Cr3, 55C3	55Cr3	2253	F.1431-55 Cr3, F.143	SUP 9 (A)		55Cr3	50ChGA
	25CD4, 25CrMo4	25CrMo4 (KB)	2225	F8372-AM26CrMo4, F8330-AM25CrMo4, F1256-30CrMo4-1, F.222	SCM420, SCM430, SCCrM1		25CrMo4	20ChM
	35CD4, 34CrMo4, 35CD4 / 34CrMo5	34CrMo4KB, 35CrMo4, 35CrMo4F	2234	F8331-AM34CrMo4, F8231-34CrMo4, F1250-35CrMo4, F1254-35CrMo4DF, F.125	SCM 432, SCCrM 3, SCM 435 H	4135, 4137, J 1268 Grade 4135H	34CrMo4	AS38ChGM
42CD4TS	41CrMo4		F8332-AM42CrMo4, F8232-42CrMo4, F1252-40CrMo4	SCm 440, JIS SCM 440		41CrMo4	40ChFA	
42CD4, 42CrMo4	38CrMo4KB, 42CrMo4, G40CrMo4	2244	F8332-AM42CrMo4, F8232-42CrMo4, F1252-40CrMo4	SCM 440 (H), SNB 7, JIS SCM 440		42CrMo4		
12CD4			F.1551-12CrMo4	SCM 415 (H)				



Werkstoff-Vergleichstabelle

Material – comparison table

Tavola comparativa dei materiali

ISO	Zerspanungsgruppe	Deutschland Germany Germania W.-Nr. DIN	Deutschland Germany Germania W.-Nr. DIN EN	Deutschland Germany Germania DIN	Deutschland Germany Germania DIN EN	Deutschland – Herstellerbezeichnung Germany – Manufacturer's designation Germania – identificazione del produttore	Großbritannien Great Britain Gran Bretagna B.S.	Großbritannien Great Britain Gran Bretagna EN
Bau- und Konstruktionsstähle / Structural and constructional steels / Acciai da costruzione								
P	P7	1.7335		13 CrMo 4 4	13CrMo4-5		620-440, 1503-620-440, 1502, 620-470, 3606-620, 620-540, 3604-620-440	
	P7 / P10	1.7361		32 CrMo 12	32CrMo12		722M24	40B
	P7	1.7380		10 CrMo 9 10	10CrMo9-10		3059-622-490, 3606-622, 1502-622, 3604-622, 622Gr.31, 622Gr.45	
	P7	1.7715		14 MoV 6 3	14MoV6-3		1503-660-460, 3604-660	
	P7 / P9	1.8159		50 CrV 4	51CrV4		735A50, 735A51, 735H51, 735M50	47
	P7	1.8509		41 CrAlMo 7	41CrAlMo7	Nitraloy 135	905M39	41B
	P7 / P10	1.8523		39 CrMoV 13 9	40CrMoV13-9		897M39	40C
Rost-, säure- und hitzebeständige Stähle / Stainless and heat resisting steels / Acciai inossidabili e leghe refrattarie								
P	P14 / P15	1.4000		X 7 Cr 13	X6Cr13		403S17	
	P14	1.4001		X 7 Cr 14	X7Cr14		403S17	
	P14 / P15	1.4006		X 10 Cr 13, X 12 Cr 13	X12Cr13, X10Cr13		410S21, 410C21, ANC1A	
	P14	1.4016		X 6 Cr 17	X6Cr17		430S15, 430S17, 430S18	60
	P15	1.4027		G-X 20 Cr 14	GX20Cr14		ANC1B, ANC1C, 420C24, 420C29	
	P15	1.4034		X 46 Cr 13	X46Cr13		420S45	
	P15	1.4057		X 20 CrNi 17 2	X19CrNi17-2, X17CrNi16-2		431S29, 6S80, S80	57
	P14 / P15	1.4104		X 12 CrMoS 17	X14CrMoS17			
	P14	1.4113		X 6 CrMo 17 1	X6CrMo17-1		434S17	
	P15	1.4313		X 4 CrNi 13 4	X3CrNiMo13-4		425C11, 425C12	
	P15	1.4718		X 45 CrSi 9 3	X45CrSi9-3-1		401S45	52
	P14	1.4724		X 10 CrAl 13, X 10 CrAlSi 13	X10CrAlSi13, X10CrAl13		403S17	
	P14	1.4742		X 10 CrAl 18, X 10 CrAlSi 18	X10CrAl18, X10CrAlSi18		430S15	60
	P15	1.4747		X 80 CrNiSi 20	X80CrNiSi20	Sil XB	443S65	59
	P14	1.4762		X 10 CrAl 24, X 10 CrAlSi 25	X10CrAl24, X10CrAlSi25			
	Werkzeugstähle / Tool steels / Acciai da utensili							
P	P4	1.1545		C 105 W 1	C105U			
	P4	1.1663		C 125 W	C125W, C125U			
	P7 / H2	1.2067		100 Cr 6	99Cr6, 102Cr6		BL3, 534A99	
	P11 / H3	1.2080		X 210 Cr 12	X210Cr12		BD3	

Werkstoff-Vergleichstabelle

Material – comparison table

Tavola comparativa dei materiali

ISO	Frankreich France Francia AFNOR	Italien Italy Italia UNI	Schweden Sweden Svezia SS	Spanien Spain Spagna UNE	Japan Japan Giappone JIS	USA USA USA AISI/SAE/ASTM	Belgien Belgium Belgio NBN	Russland Russia Russia GOST
Bau- und Konstruktionsstähle / Structural and constructional steels / Acciai da costruzione								
P	15CD3.05, 15CD4.05	14CrMo3, 16CrMo3	2216	F.2631-14CrMo45	SFVA F 12	A387 Grade 12Cl2	14CrMo45	12ChM
	30CD12	32CrMo12	2240	F.124.A			32CrMo12	
	12CD9.10, 10CrMo9-10, 10CrMo9-11	12CrMo9 (KW KG), G14CrMo9, 10	2218	TU.H	SFVAF22A, BSCMV4, SCPH32-CF	A387 Grade 22, A387 Grade 22Cl2		12Ch8
				F.2621-13 MoCrV6				13MoCrV6
	50CV4, 51CrV4, 50CrV4	50CrV4	2230	F.1430-51CrV4	SUP 10		50CrV4	50ChGFA
	40CAD6.12	41CrAlMo7	2940	F.1740-41CrAlMo7	SACM 645, JIS SACM 645		41CrAlMo7	38ChMJuA
						39CrMoV13		
Rost-, säure- und hitzebeständige Stähle / Stainless and heat resisting steels / Acciai inossidabili e leghe refrattarie								
P	Z6013, Z6Cr13, Z8C12	X6Cr13	2301	F.3110-X6 Cr13	SUS403, SUS410S, SUS429			08Ch13
	Z3014, Z8C13FF	X6Cr13		F.8401-AM-X12 Cr13	SUS403, SUS410S, SUS429	403, 410S, 429		08Ch13
	Z12C13, Z12Cr13, Z10C13	X12Cr13, X10Cr13	2302	F.3401-X12 Cr13	SUS 410, JIS SUS 410	410		12Ch13
	Z8C17, Z6Cr17	X8Cr17	2320	F.3113-X8 Cr17	SUS 430			12Ch17
	Z20C13M				SCS 2			20Ch13L
	Z40C14, Z40Cr14, Z38C13M, Z44C14	X40Cr14		F.3405-X46 Cr13				40Ch13
	Z15CN16.02	X16CrNi16	2321	F.3427-X15 CrNi16, F.313, F.3427-X19CrNi172	SUS 431, JIS SUS 431			20Ch17N2
	Z10CF17	X10CrS17	2383	F.3117-X10CrS17, F.3413-X14CrMoS17	SUS 431, SUS430F	430F, J 405 Grade 51435		
	Z8CD17.01	X8CrMo17	2325	F.3116-X6CrMo171	SUS 434			
	Z5CN13.4, Z4CND13.4M, Z6CN13-4, Z8CD17-01	GX6CrNi13 04	2385		SCS 5, SCS 6	CA6		
	Z45CS9	X45CrSi8		F.3220-X 4 ScrSi 09-03	SUH 1	HNV3		40Ch9S2
	Z10C13, Z13C13	X10CrAl12		F.13152-X 10 CrAl13		405		10Ch13SJ
	Z10CAS18, Z12CAS18	X8Cr17		F.3153-X 10 CrAl 18	SUH 21	430		15Ch18SJ
	Z80CSN20.02			F.3222-X 80CrSi- Ni20-02	SUH 4	HNV6		
	Z10CAS24, Z12CAS25	X16Cr26	2322	F.3154-X 10 CrAl24	SUH 446	446		
Werkzeugstähle / Tool steels / Acciai da utensili								
P	C105E2U, Y1105	C100KU	1880	F515, F516	SK 3 (TC105)	W110		U10A-1
	Y2120			F.5123 C120		W112		U13-1
	100Cr6RR, 100C6, Y100C6		2258	F.5230 100 Cr6, F.1310 - 100 Cr6, F.131	SUJ 2, SUJ 4	L3, 52100, L1		Ch
	X200Cr12, Z200C12	X205Cr12KU		F.5212 X210 Cr12	SKD 1, SKS	D3		Ch12



Werkstoff-Vergleichstabelle

Material – comparison table

Tavola comparativa dei materiali

ISO	Zerspanungs- gruppe	Deutschland Germany Germania W.-Nr. DIN	Deutschland Germany Germania W.-Nr. DIN EN	Deutschland Germany Germania DIN	Deutschland Germany Germania DIN EN	Deutschland – Herstellerbezeichnung Germany – Manufacturer's designation Germania – identificazione del produttore	Großbritannien Great Britain Gran Bretagna B.S.	Großbritannien Great Britain Gran Bretagna EN
Werkzeugstähle / Tool steels / Acciai da utensili								
P	P11 / H1	1.2344		X 40 CrMoV 5 1	X40CrMoV5-1		BH13	
	P11 / H3	1.2363		X 100 CrMoV 5 1	X100CrMoV5-1		BA2	
	P7 / H2	1.2419		105 WCr 6	107WCr5, 105WCr6, 100WCr6			
	P14 / H3	1.2436		X 210 CrW 12	X210CrW12-1, X210CrW12			
	P7 / H2	1.2542		45 WCrV 7	45WCrV8, 45WCrV7		BS1	
	P11 / P13	1.2581		X 30 WCrV 9 3	X30WCrV9-3		BH21	
	P14 / H3	1.2601		X 165 CrMoV 12	X165CrMoV12			
	P7 / P10 / H1	1.2713		55 NiCrMoV 6	55NiCrMoV6		BH224	
	P7 / H3	1.2833		100 V 1	100V1		BW2	
	P11 / H3	1.3243		S 6-5-2-5	HS6-5-2-5		BM35	
	P11 / H3	1.3255		S 18-1-2-5	HS18-1-2-5		BT4	
	P11 / H3	1.3343		S 6-5-2	HS6-5-2		BM2	
	P11 / H3	1.3348		S 2-9-2	HS2-9-2			
	P11 / H3	1.3355		S 18-0-1	HS18-0-1		BT1	
Rostfreier und warmfester Stahl / Stainless steel and high temperature steel / Acciai inossidabili e acciai resistenti al calore								
M	M1	1.4301		X 5 CrNi 18 10	X5CrNi18-10		304S15, 304S16, 304S31, 304S11, 304S17, LW21, LWCF21	58E
	M1	1.4305		X 10 CrNiS 18 9	X8CrNiS18-9		303S21, 303S22, 303S31	58M
	M1	1.4306		X 2 CrNi 19 11	X2CrNi19-11		304S11, LW20, LWCF20, S536, T74, 304C12 (LT196), 305S11	
	M1	1.4308		G-X 6 CrNi 18 9	GX5CrNi19-10		304C15, 304C15 (LT196)	
	M2	1.4310		X 12 CrNi 17 7	X9CrNi18-8, X10CrNi18-8		301S21, 301S22, 302S26	
	M1	1.4311		X 2 CrNiN 18 10	X2CrNiN18-10		304S62	
	M1	1.4401		X 5 CrNiMo 17 12 2	X5CrNiMo17-12-2, X4CrNiMo17-12-2, X5CrNiMo18-10		316S13, 316S17, 316S19, 316S31, 316S33, 316S16	

Werkstoff-Vergleichstabelle

Material – comparison table

Tavola comparativa dei materiali

ISO	Frankreich France Francia AFNOR	Italien Italy Italia UNI	Schweden Sweden Svezia SS	Spanien Spain Spagna UNE	Japan Japan Giappone JIS	USA USA USA AISI/SAE/ASTM	Belgien Belgium Belgio NBN	Russland Russia Russia GOST
Werkzeugstähle / Tool steels / Acciai da utensili								
P	X40CrMoV5, Z40CDV5	X40CrMoV511KU	2242	F.5318 X40 CrMoV5	SKD 61	H13		4Ch5MF1S
	X100CrMoV5, Z100CDV5	X100CrMoV51KU	2260	F.5227 X100 CrMoV5	SKD 12, JIS SKD 12	A2		
	105WC13	107WCr5KU	2140	F.5233 105 WCr5, F.523	SKS 2, SKS 3, SKS 31			
	X210CrW12-1, Z210CW12-01, Z 210 CW 12	X215CrW121KU	2312	F.5213 X210 CrW12, F.521		D6		
	45WCrV8, 45WCrV20	45WCrV8KU	2710	F.5241 45 WCrSi 8, F.524, F.524145WCrSi 8		S1		5ChW2SF
	X30WCrV9, Z30WCV9	X30WCrV93KU		F.5323 X30 WCrV9	SKD 5	H21		3Ch2W8F
		X165CrMoW12KU	2310	F.5211 X160 CrMoV12				
				F.528, F.520S		L6		5ChNM
	C105E2UV1, Y1105V, 100V2	102V2KU			SKS 43	W210		
	Z85WDCV06- 05- 05-04-02, Z90WDCV06- 05- 05-04-02	HS6-5-2-5	2723	F.5613 6-5-2-5	SKH 55	M35		R6M5K5
	Z80WKCV18- 05- 04-01	HS18-1-1-5		F.5530 18-1-1-5	SKH 3	T4		
	Z85WDCV06- 05- 04-02	HS6-5-2-5	2722	F.5603 6-5-2	SKH 51	M2		R6M5
	Z100DCWV09- 04- 02-02	HS2-9-2	2782	F.5607 2-9-2		M7		
Z80WCV18-04-01	HS18-0-1		F.5520 18-0-1	SKH 2	T1		R18	
Rostfreier und warmfester Stahl / Stainless steel and high temperature steel / Acciai inossidabili e acciai resistenti al calore								
M	Z4CN19-10FF, Z5CN17-08, Z6CN18-09, Z7CN18-09	X5CrNi18 10	2332, 233	F.3451-X5 CrNi18- 10, F.314, F.3504-X6CrNi19 10, F3504-X5CrNi1810	SUS 304	304, 304H		08Ch18N10
	Z10CNF18.09, Z8CNF18-09	X10CrNiS18 09	2346	F.3508-X10Cr- NiS18-09	SUS 303, JIS SUS 303	J 405 Grade 30303		
	Z1CN18-12, Z2CN18-10, Z3CN19.10M, Z3CN18-10, Z3CN19-11, Z3CN19-11FF	X3CrNi18 11, X2CrNi18 11, GX2CrNi19 10	2352	F.3503-X 2CrNi19- 10, F3503-X 2CrNi18- 10	JIS SCS 19, JIS SUS 304L			03Ch18N11
	Z6CN18.10M				SCS 13			07Ch18N9L
	Z12CN17.07, Z12CN18.07, Z11CN17-08, Z11CN18-08, Z12CN18-09	X12CrNi17 07	2331	F.3517-X12CrNi17 07	SUS 301	301		
	Z3CN18-07Az, Z3CN18-10AZ	X2CrNi18 11	2371	F3541-X2CrN- iN1810	SUS 304 LN	304LN		
	Z6CND17.11, Z3CD17-11-01, Z6CND17-11, Z6CND17-11-02FF, Z7CND17-11-02, Z7CND17-12-02	X5CrNiMo17 12	2347	F.3543-X5CrNi- Mo17-12, F.3543-X6 CrNi- Mo17- 12-03, F3543-X5CrNi- Mo17-122	SUS 316	316		

Werkstoff-Vergleichstabelle

Material – comparison table

Tavola comparativa dei materiali

ISO	Zerspanungsgruppe	Deutschland Germany Germania W.-Nr. DIN	Deutschland Germany Germania W.-Nr. DIN EN	Deutschland Germany Germania DIN	Deutschland Germany Germania DIN EN	Deutschland – Herstellerbezeichnung Germany – Manufacturer's designation Germania – identificazione del produttore	Großbritannien Great Britain Gran Bretagna B.S.	Großbritannien Great Britain Gran Bretagna EN
Rostfreier und warmfester Stahl / Stainless steel and high temperature steel / Acciai inossidabili e acciai resistenti al calore								
M	M1	1.4408		G-X 6 CrNiMo 18 10	GX5CrNiMo19-11-2		316C16, 316C16 (LT196), ANC4B	
	M1	1.4429		X 2 CrNiMoN 17 13 3	X2CrNiMoN17-13-3		316S62, 316S63	
	M1	1.4435		X 2 CrNiMo 18 14 3, X 2 CrNiMo 18 12	X2CrNiMo18-14-3		316S11, 316S13, 316S14, 316S31, LW22, LWCF22, 316S12	
	M1	1.4438		X 2 CrNiMo 18 16 4	X2CrNiMo18-15-4		317S12	
	M1	1.4460		X 4 CrNiMoN 27 5 2	X3CrNiMoN27-5-2			
	M1	1.4541		X 6 CrNiTi 18 10	X6CrNiTi18-10		321S12, 321S31, 321S51 (1010, 1105), LW24, LWCF24	58B, 58C
	M1	1.4550		X 6 CrNiNb 18 10	X6CrNiNb18-10		347S20, 347S31, 347S51, ANC3B	58F, 58G
	M1	1.4571		X 6 CrNiMoTi 17 12 2	X6CrNiMoTi17-12-2		320S31, 320S17, 320S18	58J
	M1	1.4581		G-X 5 CrNiMoNb 18 10	GX5CrNi- MoNb19-11-2		318C17, ANC4C	
	M1	1.4583		X 10 CrNiMoNb 18 12	X10CrNiMoNb18-12			
	M1	1.4828		X 15 CrNiSi 20 12	X15CrNiSi20-12		309S24	
	M2	1.4871		X 53 CrMnNiN 21 9	X53CrMnNiN21-9		349S54	
	M1	1.4878		X 12 CrNiTi 18 9	X12CrNiTi18-9, X10CrNiTi18-10		321S20, 321S51	58B, 58C
Warmfeste Legierung Fe-Basis / High temperature resistant alloys / Leghe refrattarie, Superleghe								
M	M1	1.4558		X 2 NiCrAlTi 32 20	X2NiCrAlTi32-20			
	M1	1.4563		X 1 NiCrMoCu 31 27 4	X1NiCrMo- Cu31-27-4			
	M1	1.4864		X 12 NiCrSi 36 16	X12NiCrSi36-16, X12NiCrSi35-16	Incoloy DS	NA17	
	M1	1.4958		X 5 NiCrAlTi31-20	X5NiCrAlTi31-20			
	M1	1.4977			X 40 CoCrNi 20 20			
	M1	1.4845		X12CrNi25-21			310S16	
Grauguss/ Cast iron / Ghisa grigia								
K	K3	0.6010	EN-JL1010	GG-10, GG 10	EN-GJL-100			
	K3	0.6015	EN-JL1020	GG-15, GG 15	EN-GJL-150		Grade 150	
	K3	0.6020	EN-JL1030	GG-20, GG 20	EN-GJL-200		Grade 220	
	K3	0.6025	EN-JL1040	GG-25, GG 25	EN-GJL-250		Grade 260	
	K4	0.6030	EN-JL1050	GG-30, GG 30	EN-GJL-300		Grade 300	
	K4	0.6035	EN-JL1060	GG-35, GG 35	EN-GJL-350		Grade 350	
	K4	0.6040		GG-40, GG 40	EN-GJL-400		Grade 400	
	K4	0.6660		GGL-NiCr 20 2			L-NiCr20 2	
	K4			GG-26Cr, GG 26Cr	EN-GJL-260 Cr			
	K7			GGV 45	EN-GJV-450			

Werkstoff-Vergleichstabelle

Material – comparison table

Tavola comparativa dei materiali

ISO	Frankreich France Francia AFNOR	Italien Italy Italia UNI	Schweden Sweden Svezia SS	Spanien Spain Spagna UNE	Japan Japan Giappone JIS	USA USA USA AISI/SAE/ASTM	Belgien Belgium Belgio NBN	Russland Russia Russia GOST
Rostfreier und warmfester Stahl / Stainless steel and high temperature steel / Acciai inossidabili e acciai resistenti al calore								
M				F.8414-AM-X7 CrNiMo20 10	SCS 14			07Ch18N10G2S2M2L
	Z2CND17.13Az	X2CrNiMoN17 13	2375	F3543- X2CrNi- MoN17133	SUS 316 LN	316LN		
	Z2CND17.13, Z3CND17-12-03, Z3CND18-14-03	X2CrNiMo17 13	2353	F.3533-X2 CrNiMo 17-12-03, F.3534-X6 CrNiMo 17-12-03		316L		03Ch17N14M3
	Z2CND19.15, Z2CND19-15-04, Z3CND19-15-04	X2CrNiMo18 16	2367	F3539-X2CrNi- Mo18164	SUS 317 L	317L		
	Z3CND25-07Az, Z5CND27-05Az		2324	F3309-X8CrNi- Mo27-05, F3552-X8CrNi- Mo266	SUS 329 J1			
	Z6CNT18.10	X6CrNiTi18 11	2337	F.3553-X7 CrNiTi 18-11, F.3523-X 6 CrNi- Ti18-11, 09 Ch 18N10T, F3523-X6CrNi- Ti1810	SUS 321, JIS SUS 321			06Ch18N10T
	Z6CNNb18.10	X6CrNiNb18 11, X8CrNiNb18 11	2338	F.3552-X 7 CrNiNb18-11, F.3524-X 67 CrNiNb18-11, F3524- X6CrNiNb1810	SUS 347			08Ch18N12B
	Z6CNDT17.12	X6CrNiMoTi17 12	2350	F.3552-X 6 CrNiMo- Ti17-12-03, F3535- X6CrNiMo- Ti17122	SUS 316 Ti	316Ti, 326Ti		10Ch17N13M2T
	Z4CNDNb18.12M	GX6CrNiMoNb20 11			SCS 22			
		X6CrNiMoNb17 13						
Z15CNS20.12, Z17CNS20-12, Z9CN24-13	X16CrNi23 14		F3312-X15CrNi- Si20-12	SUH 309	309		20Ch20N14S2	
Z52CMN21.09, Z53CMNS21-09Az, Z53CMN21-09Az	X53CrMnNiN21 9		F.3217-X53 CrMn- NiN 21-09	SUH 35, SUH 36	EV8		55Ch20G9AN4	
T6CNT18.12 (B), Z6CNT18-10		2337	F.3523-X 6CrNiTi 18 11	SUS 321	321			
Warmfeste Legierung Fe-Basis / High temperature resistant alloys / Leghe refrattarie, Superleghe								
M								
	Z12NCS37.18, Z12NCS35.16, Z20NCS33-16			F.3313-X12 CrNi 36-16	SUH 330			
	Z 42 CNKDWNb							
	Z8CN25-20	X6CrNi2521	2361		SUH310	310S		20Ch23N18
Grauguss/ Cast iron / Ghisa grigia								
K	Ft10D, FGL100	G10	110	FG 10	FC 100, FC10			Sc10
	Ft15D, FGL150	G15	115	FG 15	FC 150			Sc15
	Ft20D, FGL200	G20	120	FG 20	FC 200, FC20			Sc20
	Ft25D, FGL250	G25	125	FG 25	FC25, FC 250			Sc25
	Ft30D, FGL300	G30	130	FG 30	FC 300			Sc30
	Ft35D, FGL350	G35	135	FG 35	FC 350			Sc35
	Ft40D, FGL400		140					Sc40
	L-NC 20 2		523					

Werkstoff-Vergleichstabelle

Material – comparison table

Tavola comparativa dei materiali

ISO	Zerspanungsgruppe	Deutschland Germany Germania W.-Nr. DIN	Deutschland Germany Germania W.-Nr. DIN EN	Deutschland Germany Germania DIN	Deutschland Germany Germania DIN EN	Deutschland – Herstellerbezeichnung Germany – Manufacturer's designation Germania – identificazione del produttore	Großbritannien Great Britain Gran Bretagna B.S.	Großbritannien Great Britain Gran Bretagna EN
Kupfer und Kupferlegierungen / Copper and copper alloys / Leghe di Rame								
K	K5	0.7040	EN-JS1030	GGG-40	EN-GJS-400-15		420 / 12	
	K6	0.7050	EN-JS1050	GGG-50	EN-GJS-500-7		500 / 7	
	K6	0.7060	EN-JS1060, EN-JS 1092	GGG-60	EN-GJS-600-3, EN-GJS-600-3U		600 / 3	
	K6	0.7070	EN-JS1070, EN-JS 1102	GGG-70	EN-GJS-700-2, EN-GJS-700-2U		700 / 2	
Temperguss / Malleable cast iron / Ghisa malleabile								
K	K1	0.8035	EN-JM 1010	GTW-35, GTW-35-04	GTW-35-04, EN-GJMW-350-4		W 35-04	
	K1	0.8040	EN-JM 1030	GTW-40-05, GTW-40	EN-GJMW-400-5, GTW-40-05		W 410 / 4	
	K1	0.8045	EN-JM 1040	GTW-45-07, GTW-45	EN-GJMW-450-7		45-07	
	K1	0.8135	EN-JM 1130	GTS-35-10, GTS-35	EN-GJMB 350-10		B 340 / 12	
	K1	0.8145	EN-JM 1140	GTS-45-06, GTS-45	EN-GJMB 450-6, GTS-45-06		P 440 / 7, P 45-06	
	K1	0.8155	EN-JM 1160	GTS-55-04, GTS-55	EN-GJMB 550-4, GTS-55-04		P 540 / 5, P 55-04	
	K2	0.8165	EN-JM 1180	GTS 65-02, GTS-65	EN-GJMB 650-2, GTS-65-02		P 65-02	
	K2	0.8170	EN-JM 1190	GTS 70-02, GTS-70	EN-GJMB 700-2, GTS-70-02		P 70-02	
	K5	0.7043	EN-JS 1020	GGG-40.3	EN-GJS-400-18		370/17	
Aluminiumlegierung / Aluminium alloys / Leghe di Alluminio								
N	N1	3.0255	EN AW-1050A	Al99.5	Al99.5		1B	
	N4	3.1371	EN AC-21000	G-AlCu4TiMg	G-AlCu4TiMg			
	N2	3.1655	EN AW-2011	AlCu6BiPb	AlCu6BiPb		FC1	
	N2	3.1734		Y-Legierung	AlCu4Mg1.5Ni2, WL 3.1734		LM14	
	N4	3.2371	EN AC-42100	G-AlSi7Mg	G-AlSi7Mg, AlSi7Mg		2L99, LM25	
	N4	3.2373	EN AC-43300	G-AlSi9Mg	G-AlSi9Mg, AlSi9Mg			
	N4	3.2381	EN AC-43000	G-AlSi10Mg	G-AlSi10Mg, AlSi10Mg		LM9	
	N4	3.2382	EN AC-43400	GD-AlSi10Mg	AlSi10Mg(Fe)		LM9	
	N4	3.2383	EN AC-43200	G-AlSi10MgCu	G-AlSi10MgCu, AlSi10Mg (Cu)			
	N3	3.2581	EN AC-44200	G-AlSi12	G-AlSi12, AlSi12		LM6	
	N3	3.2582	EN AC-44300	GD-AlSi12	GD-AlSi12, AlSi12 (Fe)		LM6, LM20	
	N3	3.2583	EN AC-47000	G-AlSi12 (Cu)	G-AlSi12 (Cu)		LM20	
	N2	3.3315	EN AW-5005A	AlMg1	AlMg1C		N41	
	N3	3.3561	EN AC-51300	G-AlMg5	G-AlMg5		N6, LM5	
	N2	3.4345	EN AW-7022	AlZnMgCu0.5	AlZnMgCu0.5			
Kupfer und Kupferlegierungen / Copper and copper alloys / Leghe di Rame								
N	N7	2.0240	CW502L	CuZn15	CuZn15	Mittelrottbak, Goldtbak	CZ 102	
	N7	2.0265	CW505L	CuZn30	CuZn30	Halbtombak, LStmessing, Cartridge Messing, Cuirve Poli, Metarsic	CZ 106	
	N7	2.0321	CW508L	CuZn37	CuZn37	Druckmessing, EtzqualitSt, Stimmenmessing, Weichmessing, PrSgemessing	CZ 108	
	N7	2.0592	CC765S	G-CuZn35Al1, GK-CuZn35Al1, GZ-CuZn35Al1	CuZn35Mn2Al- 1Fe1-C		HTB 1	

Werkstoff-Vergleichstabelle

Material – comparison table

Tavola comparativa dei materiali

ISO	Frankreich France Francia AFNOR	Italien Italy Italia UNI	Schweden Sweden Svezia SS	Spanien Spain Spagna UNE	Japan Japan Giappone JIS	USA USA USA AISI/SAE/ASTM	Belgien Belgium Belgio NBN	Russland Russia Russia GOST
Kupfer und Kupferlegierungen / Copper and copper alloys / Leghe di Rame								
K	FGS 400-12	GS400-12	717		FCD 400, FCD40			VC42-12
	FGS 500-7	GS500-7	727		FCD 500, FCD50			VC50-2
	FGS 600-3	GS600-3	732		FCD 600, FCD60			VC60-2
	FGS 700-2	GS700-2	737		FCD 700, FCD70			VC70-2
Temperguss / Malleable cast iron / Ghisa malleabile								
K	MB 35-7				FCMW 330			
	MB 40-10				FCMW 350			
	MB 45-7				FCMWP 440			
	MN 35-10		815		FCMB 340			
	MP 50-5		854					
	MP 60-3		856					
			862					
	MP 70-2		862					
FGS370-17	GS042/15	0717-15					VC42-12	
Aluminiumlegierung / Aluminium alloys / Leghe di Alluminio								
N	A5	4507	4007	L-3051	A1x1, A1050	1050A		
	A-U5GT			L-2140	AC1B			
	A-U5PbBi	6362	4355	L-3182	A2011			
	A-U4NT	3045		L-2150	AC5A			
	A-S7G0.3	7257	4244	L-2651	AC4C, JIS AC4 CH (AL 9)			
	A7-S10G	3051	4253		AC4A, JIS AC4 A (AL 4)			
	A-S10G	3051	4253	L-2560, L-2561	JIS AC4 A (AL 4V)			
	A-S10G	3051	4253	L-2560, L-2561	AC4A			
	A-S9GU				JIS ADC3 (AL 4)			
	A-S13	4514	4261	L-2520, L-2521	AC3A			
	A-S13, A-S12	4514, G-AISI13	4261	L-2520, 21	AC3A			
	A-S12U	3048	4260	L-2530	ADC1 (AK 12), AC3A (AL 12)	413.1		
	A-G0, 6	5764	4106	L-3350	A2x8, A5005	5005A		
	A-G6	3058	4146	L-3320	JIS AC7A (AL28)	5056A, 514.1		
A-Z5GU0.6								
Kupfer und Kupferlegierungen / Copper and copper alloys / Leghe di Rame								
N	CuZn15				C2300			
	CuZn30				C2600			
	CuZn37				C2720			

Werkstoff-Vergleichstabelle

Material – comparison table

Tavola comparativa dei materiali

ISO	Zerspanungsgruppe	Deutschland Germany Germania W.-Nr. DIN	Deutschland Germany Germania W.-Nr. DIN EN	Deutschland Germany Germania DIN	Deutschland Germany Germania DIN EN	Deutschland – Herstellerbezeichnung Germany – Manufacturer's designation Germania – identificazione del produttore	Großbritannien Great Britain Gran Bretagna B.S.	Großbritannien Great Britain Gran Bretagna EN	
Kupfer und Kupferlegierungen / Copper and copper alloys / Leghe di Rame									
N	N7	2.0596	CC764S	G-CuZn34Al2, GK-CuZn34Al2, GZ-CuZn34Al2	CuZn34Mn3Al- 2Fe1-C				
	N7	2.0966	CW307G	CuAl10Ni5Fe4	CuAl10Ni5Fe4		CA 104		
	N7	2.0975	CC333G	G-CuAl11Ni, G-CuAl10Ni	G-CuAl11Ni		AB2		
	N7	2.1050	CC480K	G-CuSn10Zn	CuSn10-C		G1, CT1		
	N7	2.1052	CC483K	G-CuSn12, GZ-CuSn12, GC-CuSn12	CuSn12-C		Pb2		
	N9	2.1090	CC493K	G-CuSn7ZnPb, GZ-CuSn7ZnPb, GC-CuSn7ZnPb	CuSn7Zn4Pb7-C	Rotguss 7			
	N9	2.1096	CC491K	G-CuSn5ZnPb	CuSn5Zn5Pb5-C	Rotguss 5	LG2		
	N9	2.1098	CC490K	G-CuSn2ZnPb	CuSn3Zn8Pb5-C	Alloy 5A	LG1		
	N9	2.1176	CC495K	G-CuPb10Sn, GZ-CuPb10Sn, GC-CuPb10Sn	CuSn10Pb10-C		LB2		
	N9	2.1182	CC496K	G-CuPb15Sn, GZ-CuPb15Sn, GC-CuPb15Sn	CuSn7Pb15-C		LB1		
	N9	2.1188	CC497K	G-CuPb20Sn	CuSn5Pb20-C		LB5		
	N7	2.1293	CW106C	CuCrZr	CuCr1Zr		CC 102		
	N7			CuAl6.5Fe2.5Sn0.25		AMPCO 8			
	N7					AMPCO 6			
	N10			CuAl13Fe4.5		AMPCO 21			
	N10					AMPCO 26			
Magnesiumlegierung / Magnesium alloys / Leghe di magnesio									
N	N6	3.5101	EN-MC35110	G-MgZn 4 SE 1 Zr 1	EN-MCMgZn4RE1Zr, G-MgZn4SE1Zr1		RZ5, MAG5, MAG9, TZ6		
	N6	3.5103	EN-MC65120	G-MgSE 3 Zn 2 Zr 1	EN-MCMgRE3Zn2Zr, G-MgSE3Zn2Zr1		ZRE1, MAG6		
	N6	3.5106	EN-MC65210	G-MgAg 3 SE 2 Zr 1	EN-MCMgRE2Ag2Zr, G-MgAg3SE2Zr1		MSR, QE22		
	N6	3.5161		MgZn6Zr, MgZn 6 Zr F 29	MgZn6Zr, MgZn6Zr F29		ZW1, ZW3, ZW6, ZW21, MAG 161, MAG 131, MAG 141, MAG 151		
	N6	3.5200		MgMn2	MgMn2		MAG 101, AM503		
	N6	3.5312		MgAl3Zn	MgAl3Zn		AZ31, MAG 111		
	N6	3.5470	EN-MC21320	MgAl4Si1	EN-MCMgAl4Si				
	N6	3.5612		MgAl6Zn	MgAl6Zn		MAG121, AZM		
	N6	3.5632	EN-MC21150	G-MgAl 6 Zn 3	G-MgAl6Zn3	AZ63			
	N6	3.5662		G-MgAl 6	G-MgAl6				
	N6	3.5812	EN-MC21110	G-MgAl 8 Zn 1	G-MgAl8Zn1	AZ81 hp	MAG1, MAG2, AZ80, AZ81, A8		
	N6	3.5912	EN-MC21120	GD-MgAl 9 Zn 1	GD-MgAl9Zn1	AZ91	AZ91, MAG3, MAG7		
	Duroplast / Duroplastics / Duroplastiche								
	N	N12					EP, Epoxid, Epoxy		
N12						Bakelite			
N12						Pertinax			
N12						Resitex			
Thermoplast / Thermoplastic / Termoplastiche									
N	N11					PMMA, Polymethyl- metacrylate, Plexiglass, Acrylic glass			
	N11					PC, Polycarbonate, Makrolon			
	N11					PA, Polyacrylamide			

Werkstoff-Vergleichstabelle

Material – comparison table

Tavola comparativa dei materiali

ISO	Frankreich France Francia AFNOR	Italien Italy Italia UNI	Schweden Sweden Svezia SS	Spanien Spain Spagna UNE	Japan Japan Giappone JIS	USA USA USA AISI/SAE/ASTM	Belgien Belgium Belgio NBN	Russland Russia Russia GOST
Kupfer und Kupferlegierungen / Copper and copper alloys / Leghe di Rame								
N	CuAl9Ni5Fe3Mn, U-A10N							
	CuAl11Ni5Fe	G-CuAl11Fe4Ni4						
	A53-707, CuSn12							
	CuSn7Pb6Zn4							
	CuPb5Sn5Zn5							
	CuPb10Sn10							
	CuPb20Sn5							
		CuCrZr						
Magnesiumlegierung / Magnesium alloys / Leghe di magnesio								
N	G-Z4TR, ZH62							
	G-TR3Z2							
	G-Ag2.5							
						M1		
	G-M2							
	G-A3Z1, AZ31							
	G-A4S1							
	G-A6Z1, AZ61							
	AZ63							
	G-A9, AZ81							
	AZ81 hp		AZ81 hp					
G-A9Z1, AZ91								
	AZ91 hp		HK31					
Duroplast / Duroplastics / Duroplastiche								
N	Phenolic							
Thermoplast / Thermoplastic / Termoplastiche								
N								



Werkstoff-Vergleichstabelle

Material – comparison table

Tavola comparativa dei materiali

ISO	Zerspanungsgruppe	Deutschland Germany Germania W.-Nr. DIN	Deutschland Germany Germania W.-Nr. DIN EN	Deutschland Germany Germania DIN	Deutschland Germany Germania DIN EN	Deutschland – Herstellerbezeichnung Germany – Manufacturer's designation Germania – identificazione del produttore	Großbritannien Great Britain Gran Bretagna B.S.	Großbritannien Great Britain Gran Bretagna EN
Titan und Titanlegierung / Titanium and titanium alloys / Titanio e leghe di Titanio								
S	S6	3.7025		Ti 1	Ti 99.8	TitaniumGrade1	TA.1	
	S7	3.7115.1		TiAl 5 Sn 2	TiAl5Sn2.5			
	S6	3.7124		TiCu2	TiCu2		TA.21, TA.22, TA.23, TA.24, TA.52, TA.53, TA.54, TA.55, TA.58	
	S7	3.7164, 3.7165		TiAl 6 V 4	TiAl6V4	TitaniumGrade5	TA.10, TA.11, TA.12, TA.13, TA.28, TA.56	
Warmfeste Legierung Ni-/Co-Basis / High temperature resistant alloys, Ni- or Co-alloyed / Leghe resistenti al calore, base Ni o Co								
S	S3	2.4360		NiCu30Fe	NiCu30	Monel 400	3072-76, NA13	
	S4	2.4375		NiCu30Al	NiCu30Al3Ti	Monel K500	3072-76, HC202, 3146, NA18	
	S3	2.4630		NiCr20Ti		Nimonic 75	HR5, 703 B, 203-4	
	S3	2.4642		NiCr30Fe		Inconel 690, Alloy 690		
	S4	2.4668		NiCr19Fe19NbMo, NiCr19Fe19Nb5Mo3, NiCr19NbMo	NiCr19Nb5Mo3	Inconel 718, Udimet 630	HR 8	
	S4	2.4669		NiCr15Fe7TiAl, Alloy X-750	NiCr15Fe7Ti2Al	Inconel X-750, Alloy X-750	HR 505	
	S3	2.4856		NiCr22Mo9Nb, Alloy 625	NiCr22Mo9Nb	Inconel 625		
	S3	2.4858		NiCr21Mo, Alloy 825	NiFe30Cr21Mo3	Incoloy 825	3072-76	
Gehärtetes Gusseisen / Hardened cast iron / Acciaio Temprato								
H	H4	0.9640		G-X300CrMoNi1521	GX300CrMo-Ni15-2-1		Grade3A, Grade3B, BS4844	
	H4	0.9645		G-X260CrMoNi2021	GX260CrMo-Ni20-2-1		Grade3C	
	H4	0.9650		G-X260Cr27	GX260Cr27		Grade3D	
	H4	0.9655		G-X300CrMo271	GX300CrMo27-1		Grade3E	
Hartguss / Hard cast iron / Ghisa Temprata								
H	H4	0.9620		G-X260NiCr42	GX260NiCr42	Ni-Hard 2	Grade2A, BS4844 (1986) 2A	
	H4	0.9625		G-X330NiCr42	GX330NiCr42	Ni-Hard 1	Grade2B, BS4844 (1986) 2B	
	H4	0.9630		G-X300CrNiSi952	GX300CrNiSi952	Ni-Hard 4	Grade2C, Grade2D, Grade2E, BS4844 (1986) 2E	
	H4	0.9635		G-X300CrMo153	GX300CrMo15-3		Grade3A;B, Grade3B	

Werkstoff-Vergleichstabelle

Material – comparison table

Tavola comparativa dei materiali

ISO	Frankreich France Francia AFNOR	Italien Italy Italia UNI	Schweden Sweden Svezia SS	Spanien Spain Spagna UNE	Japan Japan Giappone JIS	USA USA USA AISI/SAE/ASTM	Belgien Belgium Belgio NBN	Russland Russia Russia GOST
Titan und Titanlegierung / Titanium and titanium alloys / Titanio e leghe di Titanio								
S	T-35			Ti-P01				
	T-U2			Ti-P11				
	T-A6V			Ti-P63		4911, 4928, 4935, 4954, 4965, 4967		
Warmfeste Legierung Ni-/Co-Basis / High temperature resistant alloys, Ni- or Co-alloyed / Leghe resistenti al calore, base Ni o Co								
S	NU30					AMS 4676		
	NC 20 T							
	NC 19 FeNb							
	NC 15 FeTNb					5542G		
	NC 22 FeDNB							
	NC 21 FeDU							
	Gehärtetes Gusseisen / Hardened cast iron / Acciaio Temprato							
H			466					
	Hartguss / Hard cast iron / Ghisa Temprata							
H			512					
			513					
			457					



Härtevergleich

Hardness – comparison table

Comparazione delle durezze

255	80	76,0	–
270	85	80,7	–
285	90	85,5	–
305	95	90,2	–
320	100	95,0	–
335	105	99,8	–
350	110	105	–
370	115	109	–
385	120	114	–
400	125	119	–
415	130	124	–
430	135	128	–
450	140	133	–
465	145	138	–
480	150	143	–
495	155	147	–
510	160	152	–
530	165	156	–
545	170	162	–
560	175	166	–
575	180	171	–
595	185	176	–
610	190	181	–
625	195	185	–
640	200	190	–
660	205	195	–
675	210	199	–
690	215	204	–
705	220	209	–
720	225	214	–
740	230	219	–
755	235	223	–
770	240	228	20,3
785	245	233	21,3
800	250	238	22,2
820	255	242	23,1
835	260	247	24,0
850	265	252	24,8
865	270	257	25,6
880	275	261	26,4
900	280	266	27,1
915	285	271	27,8
930	290	276	28,5
950	295	280	29,2
965	300	285	29,8
995	310	295	31,0
1030	320	304	32,2
1060	330	314	33,3
1095	340	323	34,4
1125	350	333	35,5
1155	360	342	36,6
1190	370	352	37,7
1220	380	361	38,8
1255	390	371	39,8
1290	400	380	40,8
1320	410	390	41,8
1350	420	399	42,7
1385	430	409	43,6
1420	440	418	44,5
1455	450	428	45,3
1485	460	437	46,1

Härtevergleich

Hardness – comparison table

Comparazione delle durezze

Zugfestigkeit Tensile strength Resistenza alla trazione N/mm ²	Vickers HV	Brinell HB	Rockwell HRC
1520	470	447	46,9
1555	480	(456)	47,7
1595	490	(466)	48,4
1630	500	(475)	49,1
1665	510	(485)	49,8
1700	520	(494)	50,5
1740	530	(504)	51,1
1775	540	(513)	51,7
1810	550	(523)	52,3
1845	560	(532)	53,0
1880	570	(542)	53,6
1920	580	(551)	54,1
1955	590	(561)	54,7
1995	600	(570)	55,2
2030	610	(580)	55,7
2070	620	(589)	56,3
2105	630	(599)	56,8
2145	640	(608)	57,3
2180	650	(618)	57,8
–	660	–	58,3
–	670	–	58,8
–	680	–	59,2
–	690	–	59,7
–	700	–	60,1
–	720	–	61,0
–	740	–	61,8
–	760	–	62,5
–	780	–	63,3
–	800	–	64,0
–	820	–	64,7
–	840	–	65,3
–	860	–	65,9
–	880	–	66,4
–	900	–	67,0
–	920	–	67,5

Berechnung / Calculation / Calcolazione

Zugfestigkeit Tensile strength Resistenza alla trazione	N/mm ²	N/mm ²	N/mm ²	R _m
Vickershärte Hardness Vickers Durezza Vickers	Diamantpyramide 136° Prüfkraft F ≥ 98 N	Diamond pyramid 136° Proof strength F ≥ 98 N	Piramide diamante 136° Valore Forza F ≥ 98 N	HV
Brinellhärte Errechnet aus: Hardness Brinell calculated from: Durezza Brinell calcolata da: HB = 0,95 × HV	0,102 × F/D² = 30 N/mm² F = Prüfkraft in N D = Kugeldurchmesser in mm	0,102 × F/D ² = 30 N/mm ² F = Proof strength in N D = Ball diameter in mm	0,102 × F/D ² = 30 N/mm ² F = Valore Forza in N D = Diametro sfera in mm	HB
Rockwellhärte C Hardness Rockwell C Durezza Rockwell C	Diamantkegel 120° Gesamtprüfkraft 1471 ± 9 N	120° Diamond cone Total proof strength 1471 ± 9 N	Cono diamante 120° Valore Totale Forza 1471 ± 9 N	HRC

Umrechnungen von Härtewerten nach diesen Formeln sind nur annähernd genau. Siehe DIN 50150
Conversion of hardness according to these formulas are only approximately correct. See DIN 50150
Valori di conversioni di durezza di questa tabella sono approssimate. Vedere norma DIN50150

Freiflächenverschleiß / Flank wear / Usura sul fianco



Abrieb an der Freifläche, normaler Verschleiß nach einer längeren Eingriffszeit.

- Ursache:**
- Zu hohe Schnittgeschwindigkeit
 - Hartmetallsorte mit zu geringer Verschleißfestigkeit
 - Nicht genügend Kühlung

- Abhilfe:**
- Schnittgeschwindigkeit senken
 - Verschleißfestere HM-Sorte wählen
 - Kühlschmierstoffzufuhr verbessern

Abrasion on the flank, normal wear after a certain machining time.

- Reasons:**
- Cutting speed too high
 - Carbide grade with insufficient wear resistance
 - Insufficient amount of cooling lubricant

- Solution:**
- Reduce cutting speed
 - Select more wear resistant carbide grade
 - Improve coolant supply

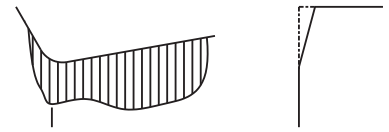

Usura sul fianco, usura normale dopo un certo tempo di lavorazione.

- Cause:**
- Velocità di taglio troppo alta
 - Qualità di metallo duro con resistenza all'usura troppo bassa
 - Insufficiente quantità di lubrorefrigerante

- Soluzioni:**
- Ridurre la velocità di taglio
 - Scegliere una qualità più resistente all'usura
 - Migliorare l'adduzione di lubrorefrigerante

Ausbröckelung / Edge chipping / Scheggiature



Durch überhöhte Beanspruchung der Schneidkante können Partikel aus der Schneidplatte ausbrechen.

- Ursache:**
- Zu verschleißfeste Sorte
 - Vibrationen
 - Zu hoher Vorschub bzw. Schnitttiefe

- Abhilfe:**
- Zähere Sorte verwenden
 - Negative Schneidengeometrie mit Spanleitstufe verwenden
 - Ausspannung reduzieren; Mittenhöhe prüfen
 - Stabilisierung der Schneidkante

Through excessive mechanical stress at the cutting edge fracture and chipping can take place.

- Reasons:**
- Grade with too high wear resistance
 - Vibrations
 - Feed rate too high or excessive depth of cut

- Solution:**
- Use tougher grade
 - Use negative cutting edge geometry with chip groove
 - Reduce overhang; check centre height
 - Increase stability of cutting edge



La sollecitazione eccessiva del tagliente può causare il distacco di particelle di metallo duro.

- Cause:**
- Qualità di M.D. con resistenza all'usura troppo elevata
 - Vibrationi
 - Avanzamento o profondità di taglio troppo elevati

- Soluzioni:**
- Usare una qualità più tenace
 - Usare una geometria negativa del tagliente con canalino formatrucolo
 - Ridurre la sporgenza, controllare l'altezza del filo tagliente
 - Stabilizzazione del tagliente

Kolkverschleiß / Cratering / Craterizzazione



Der ablaufende heiße Span verursacht eine Auskolkung der Schneidplatte an der Spanfläche.

- Ursache:**
- Zu hohe Schnittgeschwindigkeit und/oder Vorschub
 - Zu geringer Spanwinkel
 - Sorte mit zu geringer Verschleißfestigkeit
 - Falsche Kühlung

- Abhilfe:**
- Schnittgeschwindigkeit und/oder Vorschub herabsetzen
 - Kühlmittelmenge und/oder Druck erhöhen, Zuführung ändern
 - Verschleißfestere Sorte wählen

The hot chip which is being evacuated causes cratering at the rake face of the cutting edge.

- Reasons:**
- Cutting speed and/or feed rate too high
 - Rake angle too shallow
 - Grade with insufficient wear resistance
 - Incorrect coolant supply

- Solution:**
- Reduce cutting speed and/or feed rate
 - Increase coolant quantity and/or pressure, optimize coolant supply
 - Use grade which is more resistant to cratering



Il truciolo che sta per essere evacuato causa una craterizzazione dell'inserto sulla spoglia superiore.

- Cause:**
- Velocità di taglio o/e avanzamento troppo elevati
 - Angolo di spoglia superiore basso
 - Qualità di metallo duro con resistenza all'usura troppo bassa
 - Adduzione del refrigerante scorretta

- Soluzioni:**
- Ridurre la velocità di taglio e/o l'avanzamento
 - Aumentare la quantità del refrigerante e/o la pressione, controllare l'adduzione.
 - Utilizzare una qualità più resistente alla craterizzazione

Plastische Verformung / Plastic deformation / Deformazione plastica



Hohe Zerspanungstemperatur bei gleichzeitiger mechanischer Beanspruchung kann zu plastischer Verformung führen.

- Ursache:**
- Zu hohe Arbeitstemperatur, daher Erweichung des Grundmaterials
 - Ungeeignete Sorte
 - Falsche Kühlung

- Abhilfe:**
- Schnittgeschwindigkeit senken
 - Verschleißfestere HM-Sorte wählen
 - Kühlung vorsehen

High machining temperature and simultaneous mechanical stress may lead to plastic deformation.

- Reasons:**
- Too high machining temperature resulting in softening of substrate
 - Wear/heat resistance of carbide grade too low
 - Incorrect coolant supply

- Solution:**
- Reduce cutting speed
 - Choose carbide grade with higher wear resistance
 - Provide cooling



Un'alta temperatura di lavorazione insieme ad una simultanea sollecitazione meccanica può causare la deformazione plastica.

- Cause:**
- Temperatura di lavorazione troppo alta, questo comporta un cedimento del substrato
 - Qualità di M.D. non idonea
 - Adduzione del refrigerante scorretta

- Soluzioni:**
- Ridurre la velocità di taglio
 - Scegliere una qualità di metallo duro più resistente all'usura
 - Provvedere alla refrigerazione

Aufbauschneidenbildung / Built-up edge / Formazione di taglienti di riporto

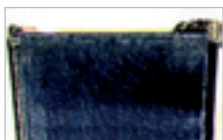

Materialaufschweißungen an der Schneidkante treten auf, wenn der Span infolge zu niedriger Schnitttemperatur nicht richtig abfließt.

- Ursache:**
- Zu geringe Schnittgeschwindigkeit
 - Zu kleiner Spanwinkel
 - Falscher Schneidstoff
 - Fehlende Kühlung/Schmierung

- Abhilfe:**
- Schnittgeschwindigkeit erhöhen
 - Spanwinkel erhöhen
 - TiN-Beschichtung einsetzen
 - Fettene Emulsionen verwenden

Built-up edge occurs when the chip is not evacuated properly due to insufficient cutting temperature.

- Reasons:**
- Cutting speed too low
 - Rake angle too small
 - Wrong cutting material
 - Lack of cooling/lubrication

- Solution:**
- Increase cutting speed
 - Enlarge rake angle
 - Apply TiN-coating
 - Use emulsion with higher concentration

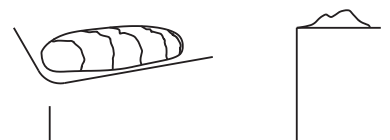

Il tagliente di riporto si presenta quando il truciolo non viene tagliato in modo corretto a causa della velocità di taglio troppo bassa.

- Cause:**
- Velocità di taglio troppo bassa
 - Angolo di spoglia superiore negativo
 - Materiale da taglio sbagliato
 - Mancanza di lubrorefrigerazione

- Soluzioni:**
- Aumentare la velocità di taglio
 - Incrementare l'angolo di spoglia superiore
 - Impiegare un rivestimento TiN
 - Utilizzare un'emulsione più grassa

Kerbverschleiß / Notching / Usura ad intaglio



Einschnürung am Spantiefenmaximum.

- Ursache:**
- Oxidation an der Schneidkante
 - Zu hohe Temperatur an der Kante

- Abhilfe:**
- Unterschiedliche Schnitttiefen verwenden
 - Schnittgeschwindigkeit herabsetzen
 - Kühlschmierstoffzufuhr verbessern

Notch at the maximum depth of cut.

- Reasons:**
- Oxidation of the cutting edge
 - Excessive heat on the cutting edge

- Solution:**
- Use various depths of cut
 - Reduce cutting speed
 - Improve coolant supply



Intaglio al livello della profondità massima di taglio.

- Cause:**
- Ossidazione sul tagliente
 - Troppo calore sul tagliente

- Soluzioni:**
- Applicare varie profondità di taglio
 - Ridurre la velocità di taglio
 - Migliorare l'adduzione del refrigerante

Berechnungseinheiten / Calculation units / Unità di misura

D	Durchmesser <i>Diameter</i> Diametro	(mm)	n	Spindeldrehzahl <i>Spindel revolution</i> Numero di giri	(U/min)
l	Länge <i>Length</i> Lunghezza	(mm)	Q	Zeitspanvolumen <i>Chip removal rate</i> Volume truciolo	(cm³/min)
v_c	Schnittgeschwindigkeit <i>Cutting speed</i> Velocità di taglio	(m/min)	P_c	Netto-Antriebsleistung <i>Power</i> Assorbimento potenza	(kW)
k_c	Spezifische Schnittkraft <i>Specific cutting force</i> Forza di taglio specifica	(N/mm²)	f_n	Vorschub pro Umdrehung <i>Feed rate per revolution</i> Avanzamento al giro	(mm/U)
a_p	Schnitttiefe <i>Depth of cut</i> Profondità di taglio	(mm)			

Formeln / Formulas / Formule

Schnittgeschwindigkeit

Cutting speed
Velocità di taglio

$$v_c = \frac{\pi \cdot D \cdot n}{1000}$$

Drehzahl

Revolutions
Numero di giri

$$n = \frac{v_c \cdot 1000}{\pi \cdot D}$$

Zeitspanvolumen

Chip removal rate
Volume truciolo

$$Q = v_c \cdot a_p \cdot f_n$$

Netto-Antriebsleistung

Power
Assorbimento potenza

$$P_c = \frac{a_p \cdot f_n \cdot k_c \cdot v_c}{6 \cdot 10^4}$$

Set Drehmoment-Schraubendreher

Torque Screwdriver Sets
Set chiavi dinamometriche



Set 1

Einstellbereich von 0,6 Nm – 1,5 Nm

Adjustable from 0,6 Nm – 1,5 Nm

Registrabile da 0,6 Nm a 1,5 Nm

- 1 Drehmoment-Schraubendreher
- je 1 Hochleistungsklinge Torx T6, Torx T7, Torx T8 und Torx T9
- 1 Einstellschlüssel

- 1 Torque screwdriver
- 1/ea Bit Torx T6, Torx T7, Torx T8 and Torx T9
- 1 Adjustment key

- 1 Chiave dinamometrica
- 1 Set di punte Torx T6, Torx T7, Torx T8, Torx T9
- 1 Chiave di registrazione

(Bestellbezeichnung: **Set-Drehmoment 1**)

(Order as: **SET-TORQUE 1**)

(Esempio di ordinazione: **Set-Drehmoment 1**)

Set 2

Einstellbereich von 1,5 Nm – 3,0 Nm

Adjustable from 1,5 Nm – 3,0 Nm

Registrabile da 1,5 Nm a 3,0 Nm

- 1 Drehmoment-Schraubendreher
- je 1 Hochleistungsklinge Torx T9, Torx T10 und Torx T15
- 1 Einstellschlüssel

- 1 Torque screwdriver
- 1/ea Bit Torx T9, Torx T10 and Torx T15
- 1 Adjustment key

- 1 Chiave dinamometrica
- 1 Set di punte Torx T9, Torx T10, Torx T15
- 1 Chiave di registrazione

(Bestellbezeichnung: **Set-Drehmoment 2**)

(Order as: **SET-TORQUE 2**)

(Esempio di ordinazione: **Set-Drehmoment 2**)

Set 3

Einstellbereich von 3,0 Nm – 5,4 Nm

Adjustable from 3,0 Nm – 5,4 Nm

Registrabile da 3,0 Nm a 5,4 Nm

- 1 Drehmoment-Schraubendreher
- je 1 Hochleistungsklinge Torx T10, Torx T15 und Torx T20
- 1 Einstellschlüssel

- 1 Torque screwdriver
- 1/ea Bit Torx T10, Torx T15 and Torx T20
- 1 Adjustment key

- 1 Chiave dinamometrica
- 1 Set di punte Torx T10, Torx T15, Torx T20
- 1 Chiave di registrazione

(Bestellbezeichnung: **Set-Drehmoment 3**)

(Order as: **SET-TORQUE 3**)

(Esempio di ordinazione: **Set-Drehmoment 3**)

Zulässige Anzugsmomente für **Wendeschneidplatten** – Spannelemente

Recommended torque settings *for indexable inserts*

Momenti torcenti raccomandati *per viti*

Gewinde Thread Filetto vite	Torx-Größe Torx size Dimensione Torx	max. Anzugsmoment max. torque Momento torcente
M1,8	T6	0,6 Nm
M2	T6	0,6 Nm
M2	T7	0,6 Nm
M2,2	T6	1,0 Nm
M2,2	T7	1,0 Nm
M2,2	T8	1,3 Nm
M3	T8	2,2 Nm
M3	T9	2,2 Nm
M3,5	T15	3,4 Nm
M4	T15	5,1 Nm
M4,5	T20	6,2 Nm
M5	T20	6,2 Nm
M6	T25	8,1 Nm

Spitzenhöhe / Edge height / Altezza del filo di taglio

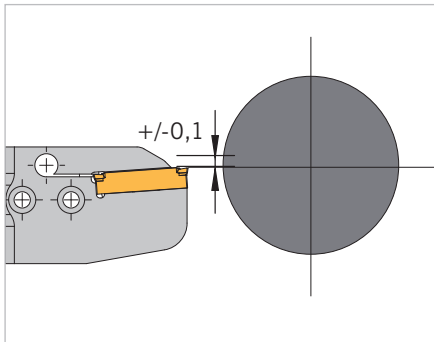

Die Spitzenhöhe sollte innerhalb einer Toleranz von $\pm 0,1$ mm zur Werkzeugachse eingestellt sein. Dies ist besonders wichtig beim Abstechen ins Zentrum.

The edge height should be inside a tolerance of ± 0.1 mm from the centre line.

L'altezza del tagliente deve essere impostata entro una tolleranza di $\pm 0,1$ mm dall'asse utensile. Questo accorgimento è indispensabile per tagli fino al centro.

Werkzeugeinstellung / Tool positioning / Preparazione dell'utensile

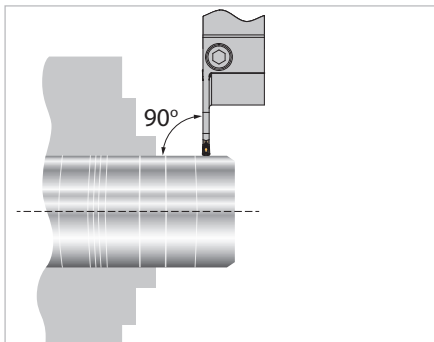

Das Stechwerkzeug muss unter einem Winkel von 90° zur Werkstückachse eingebaut sein. Das Werkstück sollte so kurz wie möglich ausgespannt werden.

The part-off tool should be positioned in 90° angle to the tool axis, the component should be held with minimum overhang.

L'utensile di troncatura deve essere montato rispetto all'asse del pezzo con un angolo di 90° . Scegliere sempre l'utensile più corto possibile.

Werkzeugauskragung / Tool overhang / Utensile a sbalzo

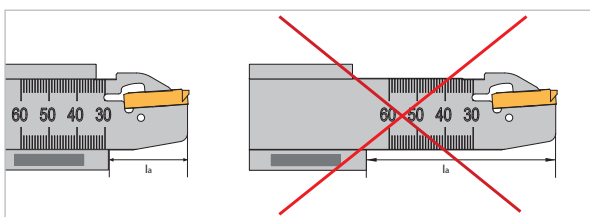

Für optimale Stabilität ist die Werkzeugauskragung immer möglichst kurz zu wählen. Als Faustregel gilt: Auskragung l_a sollte nicht größer als $8 \times s$ (Stechbreite) sein.

- Bessere Planebenheit
- Geringere Vibrationsneigung
- Höhere Standzeiten

For optimum stability it is important always to keep the tool overhang to a minimum. Ideally, overhang l_a should not be more than $8 \times$ groove width.

- Better straightness
- Reduced vibration
- Improved tool life

Per una stabilità ottimale tenere l'utensile con lo sbalzo minore possibile. Come regola generale, lo sbalzo l_a non deve essere superiore a $8 \times s$ (larghezza gola).

- Migliore planarità di taglio
- Minor tendenza a vibrazioni
- Maggiore durata

Werkzeugauskragung / Component overhang / Pezzo lungo o a sbalzo

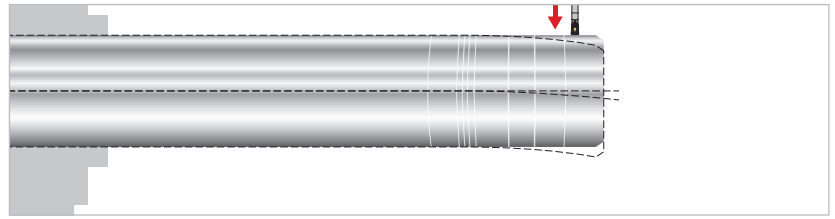
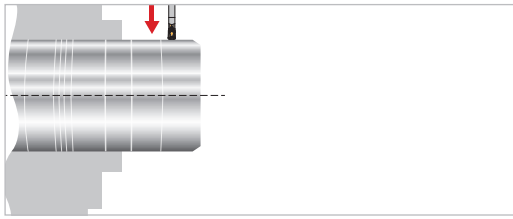

Zur Vermeidung von Vibrationen sollte das Werkstück immer möglichst kurz ausgespannt werden.

In order to reduce vibrations the component should always be clamped with as little overhang as possible.

Per evitare vibrazioni, il pezzo deve essere sempre tenuto il più corto possibile e la troncatura più vicino al mandrino possibile.

Hinweise zum Abstechen / Recommendations for parting-off / Suggerimenti per la troncatura

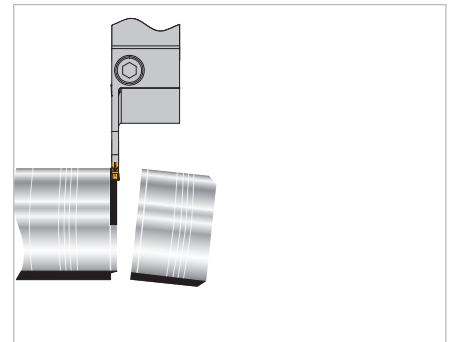
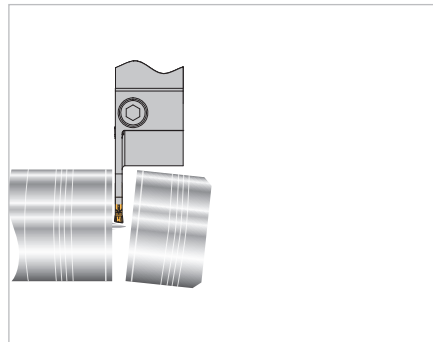
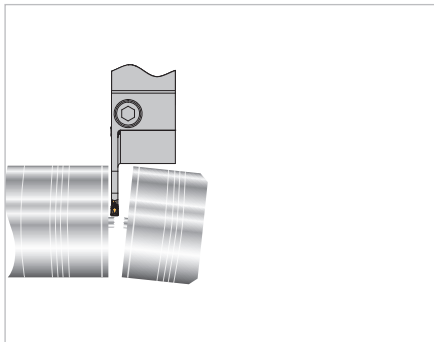

- Ab \varnothing 5 mm den Vorschub „f“ um ca. 50% reduzieren. Nicht über Zentrum stechen (Bruchgefahr).
- Zum butzenfreien Abstechen rechte bzw. linke Schneidplatten verwenden. Zur Verringerung der seitlichen Abdrängkräfte den Vorschub um ca. 20% bis 50% reduzieren.
- Zur Verhinderung von Ringbildung rechte bzw. linke Schneidplatten verwenden. Vorschub „f“ aufgrund der seitlichen Abdrängkräfte um ca. 20% bis 50% reduzieren.

- From \varnothing 5 mm reduce the feed rate “f” with approximately 50%. Do not cut over centre (risk of breakage).
- For “pip” free parting-off, use either right- or left-handed insert. To reduce deflection reduce the feed rate by 20 – 50%.
- To avoid ring formation use right- or left-handed inserts. Reduce feed rate by 20 – 50%.

- Da \varnothing 5 mm a \varnothing 0 mm ridurre avanzamento “f” di circa il 50%. Non proseguire oltre il centro (rischio di rottura).
- Per ottenere tagli sinistri utilizzare inserti destri. Per ridurre deviazione laterale, ridurre l'avanzamento di circa il 20 – 50%.
- Per un taglio sinistro di anelli utilizzare inserti destri. Ridurre l'avanzamento “F” tra il 20% e il 50% per ridurre la deviazione del taglio.

Hinweise zum Einstechen / Recommendations for grooving / Suggerimenti per la troncatura

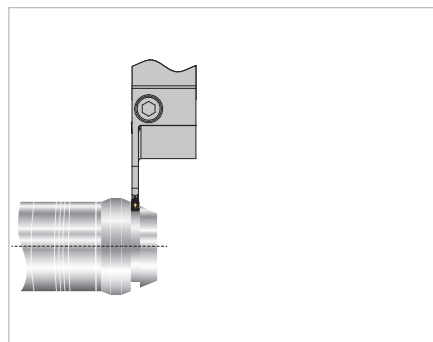
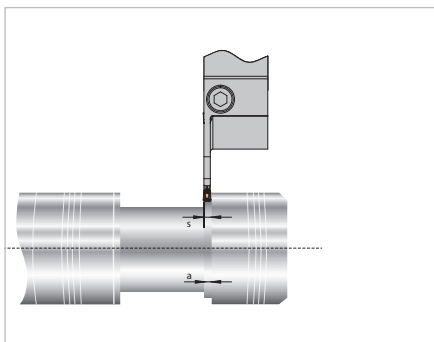

- Beim seitlich versetzten Einstechen sollte die Breite „a“ mindestens 70% der Stechbreite „s“ betragen.
- Beim Einstechen an schrägen Flächen muss der Vorschub beim Anschnitt um ca. 20% bis 50% reduziert werden.

- When grooving with an axial displacement the width “a” should be a minimum of 70% of the groove width “s”.
- When grooving into an angled surface reduce feed rate by 20 – 50% until in full cut.

- Per lavorazioni senza appoggio laterale assicurarsi che la larghezza di lavoro “a” sia almeno il 70% della larghezza inserto “s”.
- La scanalatura su superfici inclinate deve prevedere una riduzione dell'avanzamento tra il 20% ed il 50%.

Fasen und Abstechen / Chamfering and parting-off / Smussatura e troncatura

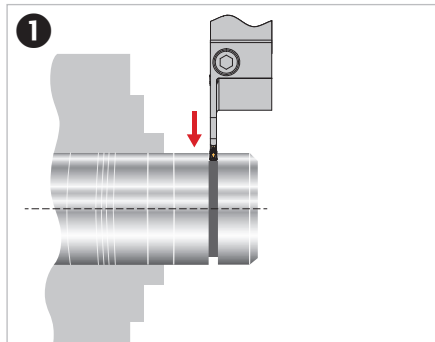

1. Vorstechen
2. Fasen
3. Abstechen

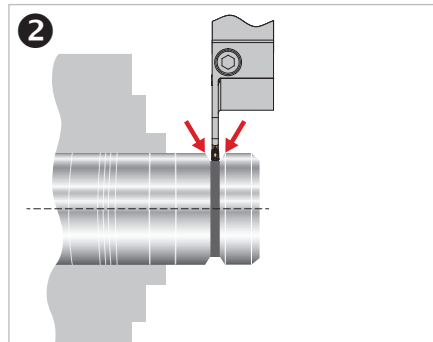

1. Pre-grooving
2. Chamfering
3. Parting-off

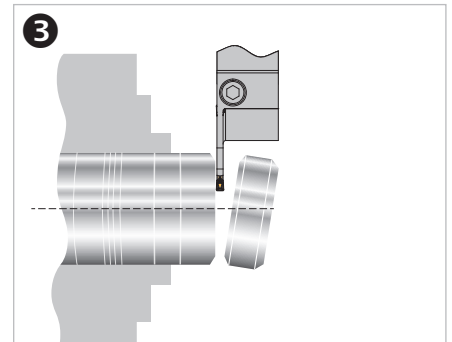

1. Pre-scanalatura
2. Smusso
3. Troncatura

Innenfasen vor dem Abstechen / Internal chamfering before parting-off / Pre-smusso interno per la troncatura

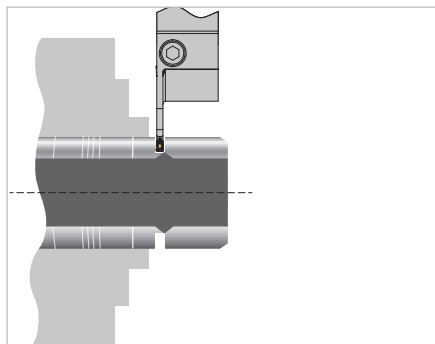

Die Schneidenecke des Faswerkzeuges und des Abstechwerkzeuges müssen genau fluchten, um ein möglichst gratfreies Ergebnis zu erzielen.

The cutting edges of the chamfer tool and part-off tool must match accurately to achieve burr free machining.

L'allineamento tra lo smusso interno e l'inserto di troncatura deve essere registrato nel modo corretto per evitare formazione di bave o profili imprecisi.

Abstechen auf einer Bohrung / Parting-off bore / Troncatura con foro

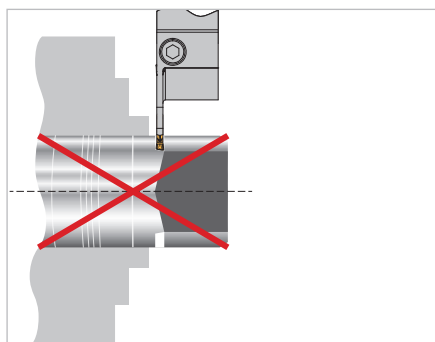

Die Bohrung muss so tief vorgebohrt werden, dass das Abstechwerkzeug mit der gesamten Schneidenbreite im zylindrischen Teil der Bohrung austritt.

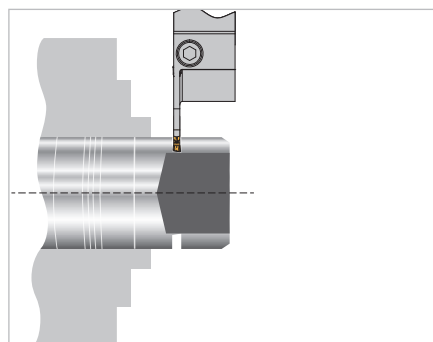

The bore must be deep enough to allow the full width of the part-off insert to break into the hole.

La profondità del foro deve superare la posizione della troncatura per permettere all'inserto di lavorare sulla parte cilindrica del foro e non sul fondo.

Stechen von Außennuten / Machining of external grooves / Scanalatura radiale

Die häufigste Methode zur Herstellung von breiten Nuten zwischen 2 Schultern erfolgt durch Mehrfacheinsteichen, Stechdrehen, Schrägeintauchen und durch Auskammern.

The most popular way of producing wide grooves in between two shoulders are by multiple grooving, groove turning, ramping, and pocketing.

Il metodo più comune per produrre ampie gole fra due spalle è con la tornitura a tuffo, con scanalature affiancate, seguendo corrette sequenze.

Mehrfacheinsteichen / Multiple grooving / Scanalatura a tuffo

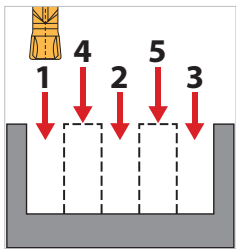

Zuerst sind die vollen Nuten zu bearbeiten. Einstiche 1, 2 und 3. Danach werden die Stege 4 und 5 bearbeitet. Dadurch werden die Eckenradien geschützt und die Späne in die Mitte des Spanbrechers abgeführt. Stegbreite 0,6 bis 0,8 x Schneidplattenbreite EB.

First the full grooves are machined. Grooves 1, 2 and 3, thereafter 4 and 5. This protects the corner radius and the swarf comes of the centre of the chip breaker. Widths of 4 and 5 should be 0.6 – 0.8 x insert width (EB).

Prima di procedere, valutare il tipo di gola e scegliere la dimensione inserto adatta per larghezza e profondità. Eseguire scanalature 1, 2 e 3; successivamente 4 e 5. In tal modo l'inserto lavora con appoggio sui fianchi, in quelle successive senza appoggio ma solo sul rompitrucciolo centrale. Prevedere profondità di gola ridotte e ripetere l'operazione fino alla massima profondità.

Stechdrehen / Groove turning / Scanalatura di copiatura

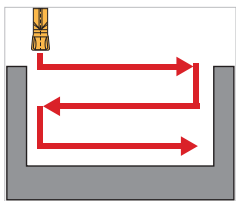

Die Schnitttiefe a_p richtet sich nach der Breite der Schneidplatte, dem zu zerspanenden Werkstoff und der Schneidkantenlänge bzw. Ausspannsituation.
Faustformel:
 $a_p \text{ max.} = EB \times 0,7$
 $a_p \text{ min.} = \text{Eckenradius „r“}$

The groove depth (a_p) depends on the width of the insert, material and the edge length of the inserts.
General rule:
 $a_p \text{ max.} = EB \times 0,7$
 $a_p \text{ min.} = \text{corner radius „r“}$

La profondità di passata è determinata dalla larghezza dell'inserto, dalla tipologia di materiale e dalla lunghezza (stabilità) del portainserito.
Regola generale:
 $a_p \text{ max.} = EB \times 0,7$
 $a_p \text{ min.} = \text{Raggio „r“}$

Nut-Fertigbearbeitung / Groove finishing machining / Finitura di gola

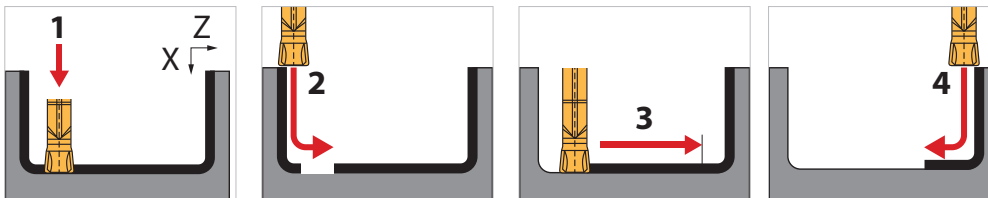

Vorsicht ist geboten bei der Fertigbearbeitung, da die Schneidplatte um den Radiusbereich am Grund fährt und die meisten Bewegungen in der Z-Richtung erfolgen. Dies führt zur Bildung dünner Späne und kann aufgrund von Vibrationen zur Behinderung des Prozesses führen. Durch Einhaltung des dargestellten Bearbeitungsablaufes lässt sich dies verhindern, wobei die axiale und radiale Schnitttiefe zwischen 0,5 und 1,0 mm liegen muss.

Take care when finishing, the radius of the insert moves mainly in the z-axis and this can produce very thin swarf which can lead to vibrations and poor surface finish. If using the machine path shown, this can be avoided, axial and radial cutting depth should be between 0.5 – 1.0 mm.

Il ciclo di finitura gola prevede una sequenza che eviti la formazione di anelli di bave. Scegliere forme di rompitrucciolo con controllo truciolo anche per avanzamenti composti e non solo in Z come per tutti gli inserti da gola. Evitare la formazione di trucioli sottili e lunghi e di vibrazioni. La sequenza rappresentata indica il metodo suggerito di lavoro per una situazione tipo prevedendo profondità di passata tra 0,5 e 1,0 mm.

Allgemein / General / Generici

Grundsätzlich sollte darauf geachtet werden, dass das Stechwerkzeug so stabil wie möglich ausgewählt wird. Dadurch können Vibrationen verhindert und die Standzeit gesteigert werden.

Bei der Auswahl der Stechplatten ist zu beachten:

- Die Abstechbreite EB in mm
- Die Spanleitstufe für die Bearbeitung
- Den Einstellwinkel und den Eckenradius

Die Stechbreite sollte so schmal wie möglich und so breit wie nötig ausgewählt werden. Durch die Reduzierung der Stechbreite wird auch die Schnittkraft reduziert und kann in der Massenfertigung zudem auch zu enormen Einsparungen an Materialkosten führen. Nach Möglichkeit sind neutrale Schneiden einzusetzen, die eine bessere Spanbildung, geringere Abdrängkräfte und höhere Standzeiten erreichen.

Pay attention to selection of the correct tools. Tools should have minimum overhang to reduce vibrations and increase of tool life.

When selecting inserts, consider:

- Parting-off width in mm
- Chip breaker for the material
- Approach angle and corner radius

Select insert width as narrow as possible and as wide a necessary. By reducing the insert width, the cutting forces are reduced and especially important when mass producing less material is wasted. Whenever possible it is always recommended to use neutral inserts that offer better swarf control and tool life.

Scegliere sempre l'utensile più compatto possibile per una maggiore stabilità. Grazie a questo le vibrazioni vengono ridotte, la lavorazione è più stabile e la durata inserto aumentata.

Nella scelta dell'inserto di scanalatura è bene valutare:

- La larghezza di taglio in mm
- La forma di rompitruciolo
- L'angolo di taglio ed il raggio di punta

La larghezza della troncatura deve essere il più stretto possibile – scegliere inserti proporzionati alla misura da realizzare. Riducendo la larghezza di taglio, si riduce la forza di taglio e può risultare in un enorme risparmio dei costi delle materie prime su grossi lotti produttivi.

Auswirkungen auf die Bearbeitung / Effects on machining / Effetti sul ciclo

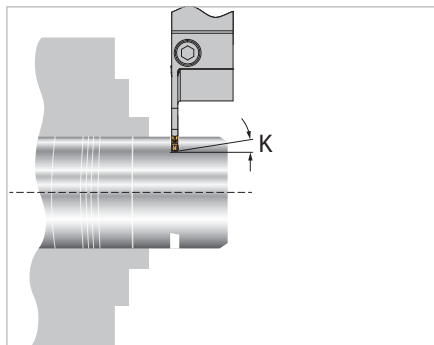
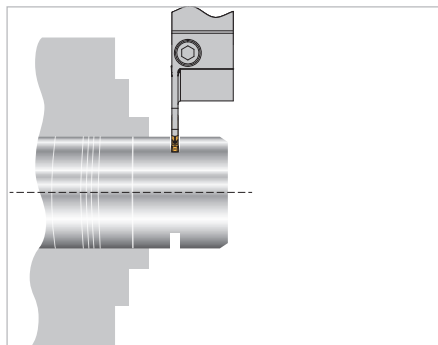

Kriterien Criteria Criteri	Schneidplatte Neutral Neutral insert Inserto neutro	Schneidplatte rechts oder links Right or left insert Inserto destro o sinistro
Stabilität / Stability / Stabilità	Gut / Good / Buono	Schlechter / Bad / Negativo
Restbutzen / Leftover chips / Testimone	Groß / Big / Grosso	Gut / Good / Buono
Gratbildung / Burr formation / Bave	Groß / Big / Grosso	Gut / Good / Buono
Vibrationen / Vibrations / Vibrazioni	Geringer / Less good / Minore	Hoch / High / Alto
Oberflächengüte / Surface finish / Finitura superficiale	Gut / Good / Buono	Schlechter / Bad / Negativo
Ebenheit / Straightness / Planarità	Gut / Good / Buono	Schlechter / Bad / Negativo
Spanfluss / Chip flow / Evacuazione truciolo	Gut / Good / Buono	Schlechter / Bad / Negativo
Standzeit / Tool life / Vita inserto	Gut / Good / Buono	Schlechter / Bad / Negativo

Bei der Auswahl des Eckenradius ist zu beachten:

- ein kleiner Eckenradius reduziert die Belastung am Werkstück und führt zu geringerer Gratbildung.
- ein größerer Eckenradius ermöglicht höhere Vorschübe und führt zu längeren Standzeiten.

When selecting corner radius:

- A smaller radius reduces the pressure on the component and reduces burr formation
- A bigger radius offers higher feed rate potential and longer tool life.

Quando si seleziona il raggio di punta devono essere rispettate:

- Un piccolo raggio di punta riduce lo stress di taglio sul pezzo e porta a bave inferiori.
- Un raggio di punta più grande consente velocità di avanzamento superiore e porta a una maggior vita inserto.

Butzenfreies Abstechen / Pip free parting-off / Troncatura

Um die Butzenbildung zu minimieren empfehlen wir geschliffene Stechplatten in Links- oder Rechtsausführung mit kleinst möglichem Einstellwinkel zu verwenden. Nur dadurch können Sie die gewünschte Werkstückqualität erzeugen.

Beachten Sie bitte, dass durch einen großen Einstellwinkel die Butzenbildung verbessert werden kann. Es kann jedoch zu einer nicht ebenen Fläche beim Abstechen führen, sich die Oberflächengüte verschlechtern und die Standzeit reduzieren wird. Bitte wählen Sie einen Halter mit kurzer Auskraglänge um eine hohe Stabilität zu erreichen.

In order to reduce the pip formation we recommend ground inserts in left- or right-hand execution with as small as possible approach angle. This may be the only way of achieving the desired surface requirement. Please note that a larger approach angle can reduce the pip formation, however can also lead to poor flatness, reduced surface finish and worse tool life. To obtain maximum stability always select a holder with minimum overhang.

Per ridurre al minimo il testimone consigliamo inserti rettificati nella versione sinistra o destra da utilizzare con il più piccolo angolo di impostazione possibile. Solo in questo modo è possibile ottenere una buona qualità del pezzo sia in termini di finitura che planarità. Il testimone può essere ridotto aumentando l'angolo di impostazione. Aumentando l'angolo di impostazione, può aumentare la deviazione del taglio portando ad una non planarità della faccia, ad una peggiore qualità superficiale e ad una durata ridotta. Scegliere sempre un utensile con il minor sbalzo per ottenere una elevata stabilità.

Gratfreies Abstechen / Burr free parting-off / Troncatura senza bave

Um eine gute Werkstückqualität zu erzielen (und um die Gratbildung zu minimieren) setzen Sie bitte geschliffene Stechplatten in Links- oder Rechtsausführung mit kleinst möglichem stirnseitigen Einstellwinkel ein. Bitte beachten Sie, dass durch einen großen Einstellwinkel die Gratbildung minimiert wird. Durch kurze Ausspannlängen des Halters sowie sicherer Schraubenspannung der Stechplatte erreichen Sie eine gute Stabilität und somit eine optimale Geradheit beim Abstechen.

In order to obtain a good burr free surface finish we recommend ground inserts in left- or right-hand execution and with minimum approach angle. Please note that a larger approach angle can improve the burr formation. With short tool overhang and secure strong insert locking you achieve excellent stability and straightness while parting-off.

Al fine di ottenere una buona finitura superficiale (e ridurre al minimo la formazione di bave) scegliere inserti rettificati sinistri o destri con il minor angolo di impostazione anteriore. Notare che la formazione di bave è ridotto al minimo più è ampio l'angolo di impostazione. Per migliorare la rettilineità del taglio e quindi la planarità della superficie, scegliere staffaggi rigidi e utensili più corti possibile.

Abstechen von Hohlkörpern / Parting-off tube / Troncatura di tubi

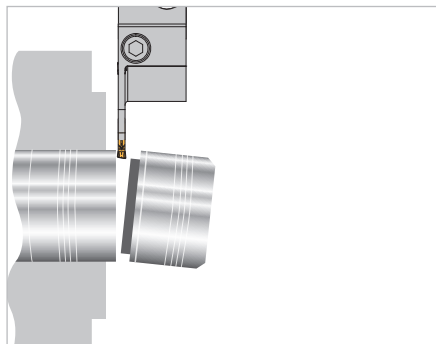

Große Auskraglängen verursachen instabile Verhältnisse und können zu Werkzeugbruch und schlechter Werkstückqualität führen. Bitte wählen Sie die Stechbreite so schmal wie möglich. Je größer der Spanwinkel, desto geringere Schnittkräfte treten auf.

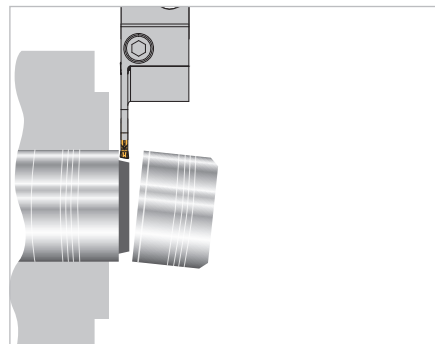

Excessive tool overhang often leads to instability, tool breakage and poor component finish. Always select tools as short and narrow as possible. Higher approach angle will lead to lower cutting forces.

Wandstärke in mm Wall thickness in mm Spessore parete in mm	Schneideinsatz Stechbreite Insert width Larghezza inserto
< 5	1
5–8	1,5–2
8–12	2,5
12–16	3
16–20	4
20–24	5
24–30	6

Lunghezze eccessive di utensili portano ad instabilità della lavorazione e ad una ridotta finitura superficiale. Scegliere sempre utensili più corti possibile e con larghezze di gola più piccole possibili. Angoli di impostazione alti riducono le forze di taglio.

Abstechen von kleinen Durchmessern oder dünnwandigen Rohren

Parting-off small diameters and thin walled components

Troncatura di piccolo diametro o tubi a parete sottile

Um die Schnittkräfte zu minimieren setzen Sie bitte präzisionsgeschliffene Stechplatten ein. Schmale Abstechbreiten kombiniert mit scharfen Schneidkanten sind zu empfehlen.

In order to reduce cutting forces, we recommend ground inserts. Narrow part-off widths with sharp cutting edges is recommended.

Per ridurre al minimo le forze di taglio utilizzare inserti di troncatura rettificati. Sono suggeriti inserti con larghezza minima e tagliente affilato.

Präzisionseinstechen / Precision grooving / Scanalatura di precisione

Präzisionseinstechen ist die wirtschaftlichste und produktivste Methode zur Herstellung von Nuten. Im ARNO-Stechprogramm stehen Ihnen hier eine Vielfalt an Stechbreiten zur Verfügung. In der Breitentoleranz auf +/- 0,02 mm geschliffen.

Precision grooving is the most economical and productive method of groove production. In the ARNO grooving range you will find numerous groove widths, ground to +/- 0.02 mm width tolerance.

La scanalatura con inserti di precisione è il metodo più economico e produttivo per la lavorazione di gole. Nel programma ARNO una varietà di larghezze di taglio sono disponibili con Tolleranza sulla larghezza +/- 0,02 millimetri.

ALPHANUMERISCHER INDEX
ALPHANUMERICAL INDEX
INDICE ALFANUMERICO

A

A

Alphanumerischer Index

Alphanumerical index

Indice alfanumerico

Bezeichnung Designation Articolo	Seite Page Pagina	Bezeichnung Designation Articolo	Seite Page Pagina	Bezeichnung Designation Articolo	Seite Page Pagina
1		32015 VK	256	71216 L/R Axial	217
104604 ...	252	37-50NCL/R	243	71216 L/R Radial	203
104604-12	253	373225 L/R	212/233	71616 L/R Axial	217
104604-ALU	257	373225 L/R Axial	217	71616 L/R Radial	203
104608-AM	254	373225 L/R Radial	203	71616-2 L/R	206
104650 V ...	255	373232 L/R	212/233	71616-3 L/R	206
104650 VK	256	373232 L/R Axial	217	72020 L/R Axial	217
11616 L/R Axial	220	373232 L/R Radial	203	72020 L/R Radial	203
11616 L/R Radial	205	3M-../471 L/R	259	72020-2.. - 72020-3..L/R Kontra	232
11616-2.. -12020-3..L/R	216	4		72025 L/R	212/233
12020 L/R Axial	220	42202 ...	251	72025 L/R Axial	217
12020 L/R Radial	205	42202-12	253	72025 L/R Radial	203
12025 L/R Axial	220	42202-ALU	257	72525 L/R	212/233
12025 L/R Radial	205	42204 ...	251	72525 L/R Axial	217
12525 L/R-... Axial	220	42204-AM	254	72525 L/R Radial	203
122002	345	42210 ...	251	72525 L-M Axial	217
12525 L/R-... Radial	205	42220 V ...	255	72525 L-M Radial	203
13232 L/R Radial	205	42220 VK	256	73225 L/R	212/233
162502	345	452020 L/R	213	73225 L/R Axial	217
2		452025 L/R	214	73225 L/R Radial	203
2-../471 L/R	258	452525 L/R	214	732NCL/RR	243
21201 ...	251	5		740NCL/R	243
21201-12	253	52502 ...	251	750NCL/R	243
21201-ALU	257	52502-12	253	8	
21202-12	253	52502-ALU	257	83804 ...	251
21202-AM	254	52504 ...	251	83804-12	253
21204 ...	251	52504-12	253	83804-ALU	257
21210 V ...	255	52504-AM	254	83808-AM	254
21210 VK ...	256	52525 V ...	255	83840 V ...	255
213202	345	52525 VK	256	83840 VK	256
253202	345	6		9	
3		63002 ...	251	9-12 L/R - 9-16..L/R	237
3-../471 L/R	258	63002-12	253	9-20 L/R - 9-25..L/R	237
313232L/R Axial	220	63002-ALU	257	9-20NC L/R - 9-25..	239
313232L/R Radial	205	63004 ...	251	9-32 L/R	237
31602 ...	251	63008-AM	254	9-32NC L/R - 91-50NC L/R	239
31602-12	253	63010 ...	251	A	
31602-ALU	257	63030 V ...	255	AMS-472-...	376
31602-AM	254	63030 VK	256	AMS-A-...	395
31604 ...	251	7		AMS-D-...	372
31604-12	253	70808-2 L/R	206	AMS-D20	373
31615 V ...	255	70808-3 L/R	206	AMS-F-...	386
31615 VK	256	71010-2 L/R	206	AMS-G-MF.	388
32002 ...	251	71010-3 L/R	206	AMS-G-TR103...	393
32002-12	253	71212-2 L/R	206	AMS-G-WF..	390
32002-ALU	257	71212-3 L/R	206	AMS-GV-BSW...	392
32002-AM	254	71216 ..-72525 ..-M	217	AMS-GV-M...	389
32004 ...	251	71216-2.. -72020-3..L/R	215	AMS-GV-UN...	394
32004-12	253	8		AMS-GV-W228...	391
32015 V ...	255	9		A	
4		10		B	

Alphanumerischer Index

Alphanumerical index

Indice alfanumerico

Bezeichnung Designation Articolo	Seite Page Pagina
AMS-K-...	378 – 383
AMS-R-...	387
AMS-S-...	374/375
AMS-V-...	384
AMS-ZF-...	385

C	
CLCC R/L ... -A7	285
CLCC R ... -A7-A	287
CLCC R/L ... -ALU	286

G	
GWS02...-MSA-IN-ACS	572
GWS09...-MSA-IN-ACS	572
GWS202L-EQ202001-MSA-IN-ACS	574
GWS41...-MSA-IN-ACS	572
GXCCN ...	343

H	
H-AMS-...	396
H-KSA 3208 R-...-ÜK-IK	104
HABC-R-7-MSA-SL/R-ACS	532
HAMS ...-AR	365
HAMS ...-CR	363
HAMS ...-SR...	363
HAMS ...-TOR	363
HAMS 1204L/R	359
HAMS 1206L/R	359
HAMS 121204-R	367
HAMS 121206-R	367
HAMS 121206-R-GS	368
HAMS 160..R-HYD	361
HAMS 1604L/R	360
HAMS 1606L/R	359
HAMS 1608L/R	359
HAMS 2010R	359
HAMS 22...-SR	362
HAMS 2804-TR	364
HAMS 2806-TR	364
HAMS 3004-A28-SR	362
HAMS 3204-A28-SR	362
HAMS PSC3206R	366
HBSA-50-50-R-ACS	516
HBSA-65-63-...-ACS	518
HCMZ-35-...-ACS	520
HDD-45-72-R-MSA-SR-ACS	526
HDD-55-80-R-MSA-SR-ACS	526
HDD-58-58-R-MSA-SL-ACS	528
HDD-BMT45-SD-ACS	524
HDD-BMT45-SDS-ACS	522
HDD-BMT55-SD-...-ACS	524
HDD-BMT55-SDL-ACS	524

Bezeichnung Designation Articolo	Seite Page Pagina
HDD-BMT55-SDS...-ACS	522
HDD-BMT65-SD-ACS	524
HDD-BMT65-SDS-ACS	522
HDM-NL-BMT-SDL/R-ACS	558
HDM-NZ-BMT-R-MSA-SL-ACS	560
HDM-NZ-BMT-SDL/R-ACS	558
HDM-NZ/L-BMT-SDS-ACS	556
HHAR-42-68-R-MSA-SR-ACS	530
HMAZ-402...-L-...-IK	544
HMAZ40L-7-...-MSA-...-ACS	542
HMAZ40L-A1-7-...-MSA-...-ACS	540
HMD-BMT-SD	546
HMD-BMT-SDR-ACS	548
HMSA-60-75-R-MSA-SL-ACS	550
HMSA-68-56-R-ACS	548
HMSA-68-56-R-MSA-SL-ACS	554
HMSA-68-56-R-MSA-SL-ACS-S01	552
HMU-70-54-122,5-R-ACS	564
HMU-70-54-L/R-ACS	562
HNSA-RB62-L/R	566
HNSA-RB62-SDL/R-ACS	568
HNSA-RB80-R	566
HNSA-RB80-SDL/R-ACS	568
HSA 0808 L/R ...	60
HSA 1010 L/R ...	60
HSA 1010 S-L/R-...-ACS1-H4-S4	66
HSA 1212 L/R ...	60
HSA 1212 R-SA24015-S1-16	61
HSA 1212 S-L-...-ACS1-H2-S2	64
HSA 1212 S-R-...-ACS1-H2-S2G	64
HSA 1212 U-L/R ...	58
HSA 1212 UD-L-...-ACS1-S1/2	67
HSA 1212 UD-L-SA2402-20-ACS2-S1	78
HSA 1212 UD-L/R-SA2402-26	59
HSA 1212 UD-R-...-ACS1-S1/2G	67
HSA 1212 UD-R-SA2402-20-ACS2-S1G	78
HSA 1616 L/R ...	60/62
HSA 1616 L/R-...-ACS1-H1	73
HSA 1616 L/R-...-ACS1-H2	73
HSA 1616 L/R-...-ACS1-H3	74
HSA 1616 L/R-...-ACS1-S1	71
HSA 1616 L/R-...-ACS1-S2	71/72
HSA 1616 L/R-...-ACS1-UN	87/89
HSA 1616 S-L-...-ACS1-H2-S2	64
HSA 1616 S-R-...-ACS1-H2-S2G	64/65
HSA 1616 U-L/R ...	58
HSA 2020 L/R ...	60/62
HSA 2020 L/R-...-ACS1-H1	73
HSA 2020 L/R-...-ACS1-H2	73
HSA 2020 L/R-...-ACS1-H3	74
HSA 2020 L/R-...-ACS1-S1	71
HSA 2020 L/R-...-ACS1-S2	71

Bezeichnung Designation Articolo	Seite Page Pagina
HSA 2020 L/R-...-ACS1-UN	87/89
HSA 2525 L/R ...	62
HSA 2525 L/R-...-ACS1-H1	73
HSA 2525 L/R-...-ACS1-H2	73
HSA 2525 L/R-...-ACS1-H3	74
HSA 2525 L/R-...-ACS1-S1	71
HSA 2525 L/R-...-ACS1-S2	72
HSA 2525 L/R-...-ACS1-UN	87
HSA 2525 L/R-...-ACS1-UN	87/89
HSA 3225 L/R ...	62
HSA 7...L/R	116
HSA 7...L/R-ACS-UN	90/92
HSA 72032 L/R	63
HSA-7...L/R-ACS-H..	117
HSA-7...L/R-ACS-H1	79
HSA-72536 L/R	63
HSAV 20..	369
HSAV 25...	369
HSE 1212 S-R-...-ET12-ACS1-H2-S2G	164
HSE 1212 UD-L-...-ET12-ACS1-S1/2	165
HSE 1616 L/R-...-ET12-ACS1-UN	179/182
HSE 1616 L/R-...-ET21-ACS1-UN	180/183
HSE 1616 L/R-...-ET12-ACS1-H1	171
HSE 1616 L/R-...-ET12-ACS1-H2	171
HSE 1616 L/R-...-ET12-ACS1-H3	172
HSE 1616 L/R-...-ET12-ACS1-S1	169
HSE 1616 L/R-...-ET12	162
HSE 1616 L/R-...-ET21-ACS1-H1	173
HSE 1616 L/R-...-ET21-ACS1-H2	173
HSE 1616 L/R-...-ET21-ACS1-H3	174
HSE 1616 L/R-...-ET21-ACS1-S1	170
HSE 1616 L/R-...-ET21-ACS1-S2	170
HSE 1616 L/R-...-ET21	163
HSE 1616 L/R-...-ET12-ACS1-S2	169
HSE 1616 S-R-...-ET12-ACS1-H2-S2G	164
HSE 2020 L/R-...-ET12-ACS1-UN	179/182
HSE 2020 L/R-...-ET21-ACS1-UN	180/183
HSE 2020 L/R-...-ET12-ACS1-H1	171
HSE 2020 L/R-...-ET12-ACS1-H2	171
HSE 2020 L/R-...-ET12-ACS1-H3	172
HSE 2020 L/R-...-ET12-ACS1-S1	169
HSE 2020 L/R-...-ET12-ACS1-S2	169
HSE 2020 L/R-...-ET12	162
HSE 2020 L/R-...-ET21-ACS1-H1	173
HSE 2020 L/R-...-ET21-ACS1-H2	173
HSE 2020 L/R-...-ET21-ACS1-H3	174
HSE 2020 L/R-...-ET21-ACS1-H3	174
HSE 2020 L/R-...-ET21-ACS1-S1	170
HSE 2020 L/R-...-ET21-ACS1-S2	170
HSE 2020 L/R-...-ET21	163
HSE 2525 L/R-...-ET12-ACS1-UN	179/182
HSE 2525 L/R-...-ET21-ACS1-UN	180/183



Alphanumerischer Index

Alphanumerical index

Indice alfanumerico

Bezeichnung Designation Articolo	Seite Page Pagina
HSE 2525 L/R-...-ET12-ACS1-H1	171
HSE 2525 L/R-...-ET12-ACS1-H2	171
HSE 2525 L/R-...-ET12-ACS1-H3	172
HSE 2525 L/R-...-ET12-ACS1-S1	169
HSE 2525 L/R-...-ET12-ACS1-S2	169
HSE 2525 L/R-...-ET12	162
HSE 2525 L/R-...-ET21-ACS1-H1	173
HSE 2525 L/R-...-ET21-ACS1-H2	173
HSE 2525 L/R-...-ET21-ACS1-H3	174
HSE 2525 L/R-...-ET21-ACS1-S1	170
HSE 2525 L/R-...-ET21-ACS1-S2	170
HSE 2525 L/R-...-ET21	163
HSIMA-...	415
HSIMB-...	415
HSIMC-...	416
HSIMD-...	416
HSIMD-321220SL	417
HSIMZ-...	415
HSK-T63-R-7-0-MSA-SL-ACS	508
HST-SK-T63-R-7-0-MSA-SL-ACS	510
HTR45-R-W7040098-KSA-32LX-ACS	538
HTR45-R-W7040134-MSA-IL-ACS	536
HTR45-R-W7040135-MSA-SR-ACS	534
HVDI 25.-	482
HVDI 25...-MSA-I-ACS	484
HVDI 25W.-	486/488
HVDI 30.-	494
HVDI 30.-...-KSA-...	496
HVDI 30W.-	498
HVDI 40.-	504
HVDS 25-1	478
HVDS 25-7	480
HVDS 25-7	480
HVDS 30-1	490
HVDS 30-7-ACS	492
HVDS 40-1	500
HVDS 40-7	502
HVDS 50-7	506

K	
KMH01-B1-...	458/459
KMH01-B2-...	460/461
KMH01-B3-...	462/463
KMH01-B4-...	464/465
KMH01-B5-...	466
KMH01-B6-...	467
KMH01-B7-...	468
KMH01-C1-...	470/471
KMH01-C2-...	472/473
KMH01-C3-...	474/475
KMH01-C4-...	476/477
KSA 26...L/R-...-20	99

Bezeichnung Designation Articolo	Seite Page Pagina
KSA 26...L/R-...-32	99
KSA 26...L/R-...-44	99
KSA 26...N	96
KSA 26...R-...-20-ÜK	100
KSA 26...R-...-32-ÜK	100
KSA 26...R-...-44-ÜK	100
KSA 26...R-...-S1-36	101
KSA 2608 L/R ...	102
KSA 2608 L/R-...-ACS2	108
KSA 2608 L/R-...-ÜK	103
KSA 2611 L/R ...	102
KSA 2611 L/R-...-ÜK	103
KSA 32...L/R-...-44	99
KSA 32...L/R-...-44-ÜK	100
KSA 32...N	96/97
KSA 3208R-SA1704-105-ÜK	98
KSA 3208 L/X-...-ACS2	111
KSA 3208 L/R ...	102
KSA 3208 L/R-...-ÜK	103
KSA 3211 L/R ...	102
KSA 3211 L/R-...-ÜK	103
KSA-TR-2608 R-...-ACS2	109
KSA-TR-2608 R-...-S1-36-ACS2	110
KSA-TR-3208-LX/R-...-ACS2	109
KSA-TR-3208LX-...-ACS	538

L	
LOMX ...EN	292
LOMX ...EN-AM	294
LOMX 240600FN-ACB	295
LOMX 32...FN-AMF	294
LOMX 320800EN-ACB1	295
LOMX 320800FN	293
LOMX 320800FN-ACB	295
LOMX 320800FN-AEC	293
LOMX 320800TN-ACB	295
LOMX 320800TN-ACB4	295
LOMX 320800TN-ALU	293

M	
MS22/32/52-...-MSA-I-...-ACS	570
MSA-I L/R-SA16...-ACS1	127
MSA-I L/R-SA24...-ACS1	127
MSA-I L/R-SA35...-ACS1	127
MSA-I LL/RR-SA16...-ACS1	128
MSA-I LL/RR-SA24...-ACS1	128
MSA-I N-SA16...	126
MSA-I N-SA24...	126
MSA-I N-SA35...	126
MSA-S L/R-SA17...	122
MSA-S L/R-SA24...	123
MSA-S L/R-SA35...	123

Bezeichnung Designation Articolo	Seite Page Pagina
MSA-S L/R-SA24...-ACS1	124
MSA-S L/R-SA35...-ACS1	124
MSA-S L/R-SA24...-ACS2	125
MSA-S L/R-SA35...-ACS2	125
MSA-S L/R-SA35...-ACS1	124
MSA-S L/R-SA35...-ACS2	125

P	
PSC...-RA-L/R	207
PSC40-L/R-7-21-MSA-IL/R-ACS	514
PSC40-L/R-7-21-MSA-SL/R-ACS	512
PSC40...	223
PSC50-L/R-7-26-MSA-SL/R-ACS	512
PSC50...	223
PSC63-L/R-7-32-MSA-SL/R-ACS	512
PSC63...	223
PSC80...	223

S	
SA16-...-F1	132
SA16-...-M1	132
SA16-...-S1	132/133
SA16-...-T1-...	132/133
SA17-...-ALU-...	135
SA17-...-M1	134
SA17-...-S1	134
SA17-...-T1	134
SA24-...-T1	136/137
SA24-...-ALU-...	137
SA24-...-F1	136
SA24-...-M1	136
SA24-...-S1	136/137
SA24-...-N	137
SA24E-...-S1	138
SA35-...-ALU-...	140
SA35-...-F1	139
SA35-...-M1	139
SA35-...-S1	139/140
SA35-...-T1	139
SA35-...	140
SA35-8040-AEC	141
SA35-8008N-M1	141
SA40-10008N-M1	141
SAN01-...	236
SAV15 ...	397
SAV20 ...	397
SAV202006-V-IK-L/R	398
SAV25 ...	397
SAV30 ...	397
SAV303008-V-IK-L/R	398
SAV40 ...	397
SBN 2020-26 K	113



Alphanumerischer Index

Alphanumerical index

Indice alfanumerico

Bezeichnung Designation Articolo	Seite Page Pagina
SBN 2520-32 K	113
SBN 3229-32 K	113
SBN-16...	112
SBN-20...	112
SBN-25...	112
SBN-32..	112
SE24-...-M2	186
SE24-...-T1	186
SE24-...ALU	187
SIM067Z-...	420
SIM067Z-F45-...	428
SIM067Z-G-...	430
SIM067Z-K18-...	424
SIM067Z-R30-...	429
SIM077Z-...	420
SIM080A-G-...	430
SIM080A-GV-...	431
SIM082A-G-TR...	433
SIM087A-G-TR...	433
SIM097A-...	420/423
SIM097A-F45-...	428
SIM097A-K18-...	424
SIM097A-K32-...	425
SIM097A-K47-...	426
SIM097A-R30-...	429
SIM097A-V-...	422
SIM097A-VF-...	427
SIM107B-G-...	430
SIM107B-G-TR...	433
SIM107B-GV-...	431/432
SIM117B-...	420/423
SIM117B-F45-...	428
SIM117B-K18-...	424
SIM117B-K32-...	425
SIM117B-K47-...	426
SIM117B-R30-...	429
SIM117B-V-...	422
SIM117B-VF-...	427
SIM137C-...	420/423
SIM137C-F45-...	428
SIM137C-G-...	430
SIM137C-G-TR...	433
SIM137C-GV-...	431
SIM137C-K18-...	424
SIM137C-K32-...	425
SIM137C-K47-...	426
SIM137C-R30-...	429
SIM137C-V-...	422
SIM137C-VF-...	427
SIM157D-...	420/423
SIM157D-404502WL/R	421
SIM157D-F45-...	428

Bezeichnung Designation Articolo	Seite Page Pagina
SIM157D-G-...	430
SIM157D-G-TR...	433
SIM157D-GV-...	431/432
SIM157D-K18-...	424
SIM157D-K32-...	425
SIM157D-K47-...	426
SIM157D-R30-...	429
SIM157D-V-...	422
SIM157D-VF-...	427
SIM172D-...	421
SIN...-L/R	246
SIS... L/R	288
ST-HSK-T63	510
STFO L/R .. 17-..	314
STFO L/R .. 31-..	314
STFO L/R 2020 K17-A1	313
STFO L/R 2020 K31-A1	313
STGO L/R ...17-A7	311
STGO L/R ...17-A7/3	311
STGO L/R ...31-A7	311
STGO L/R ...31-A7/4	311
STGO L/R ...31/2	312
STGO L/R ...31/3	312
STGO L/R ...31/4	312
SXCCN ..	342
T	
TNMU 17 ... L/R	318/322
TNMU 17 ... L/R-AX10	321
TNMU 17 ... L/R-R...	320
TNMU 17 ... L/R-V...	319
TNMU 31 ... L/R	323/327
TNMU 31 ... L/R-AX20	326
TNMU 31 ... L/R-R...	325
TNMU 31 ... L/R-V...	324
TNMU31 1... L/R	328
TNMU31 2... L-ALU	328
TNMU31 2... L-S1	328
TNMU31 2... L-T1	328
TNMU31 2... L/R	328
TNMU31 3... L/R	328
TNMU31 4... L/R	328
TNMU31 5... L/R	328
U	
UT32-2-3 L/R	209/226
UT32-3-6L	209/226
UT32L.. - UT50L..	241
UT40-3-6 L/R	209/226
UT50-2-3 R	209/226
UT50-3-6 L/R	209/226
UT63-3-6 L/R	209/226

Bezeichnung Designation Articolo	Seite Page Pagina
UT63-8-10 R	209/226
V	
VDI...RA-...	211
VDI...AX-...	229

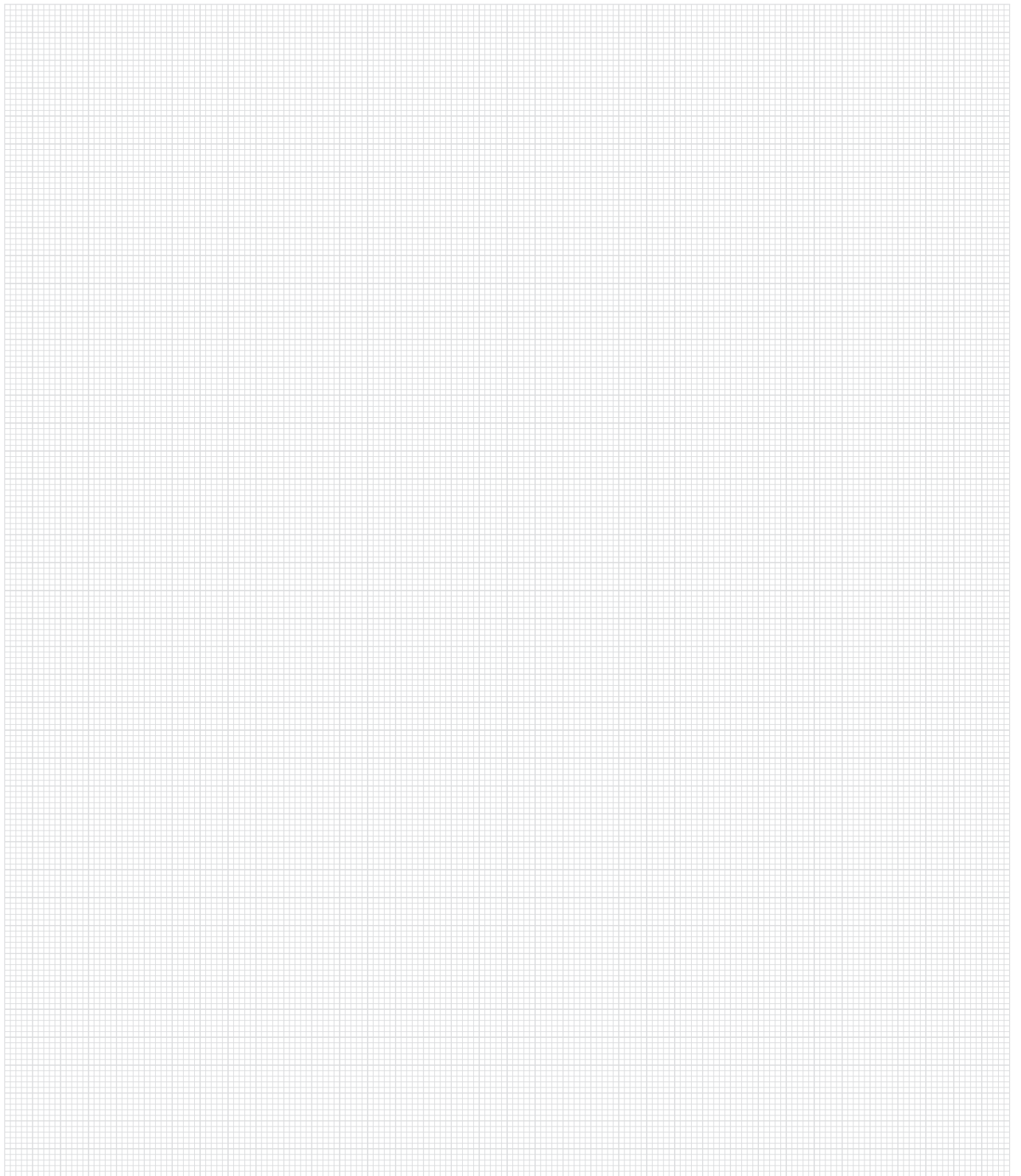

Weitere Informationen finden Sie unter
For more information see
Per maggiori informazioni visita il sito:

www.arno.de

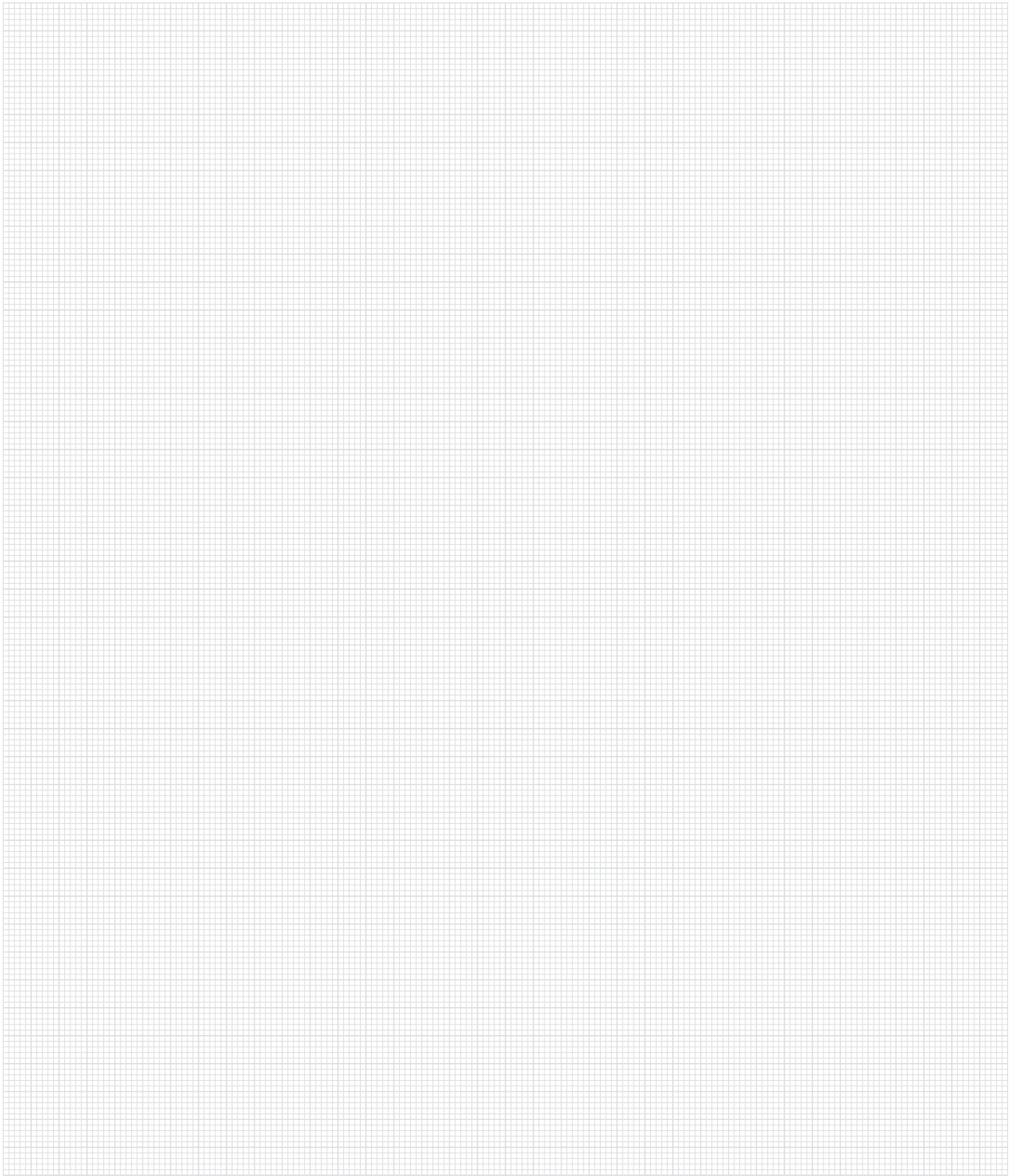

Weitere Informationen finden Sie unter
For more information see
Per maggiori informazioni visita il sito:



www.arno.de

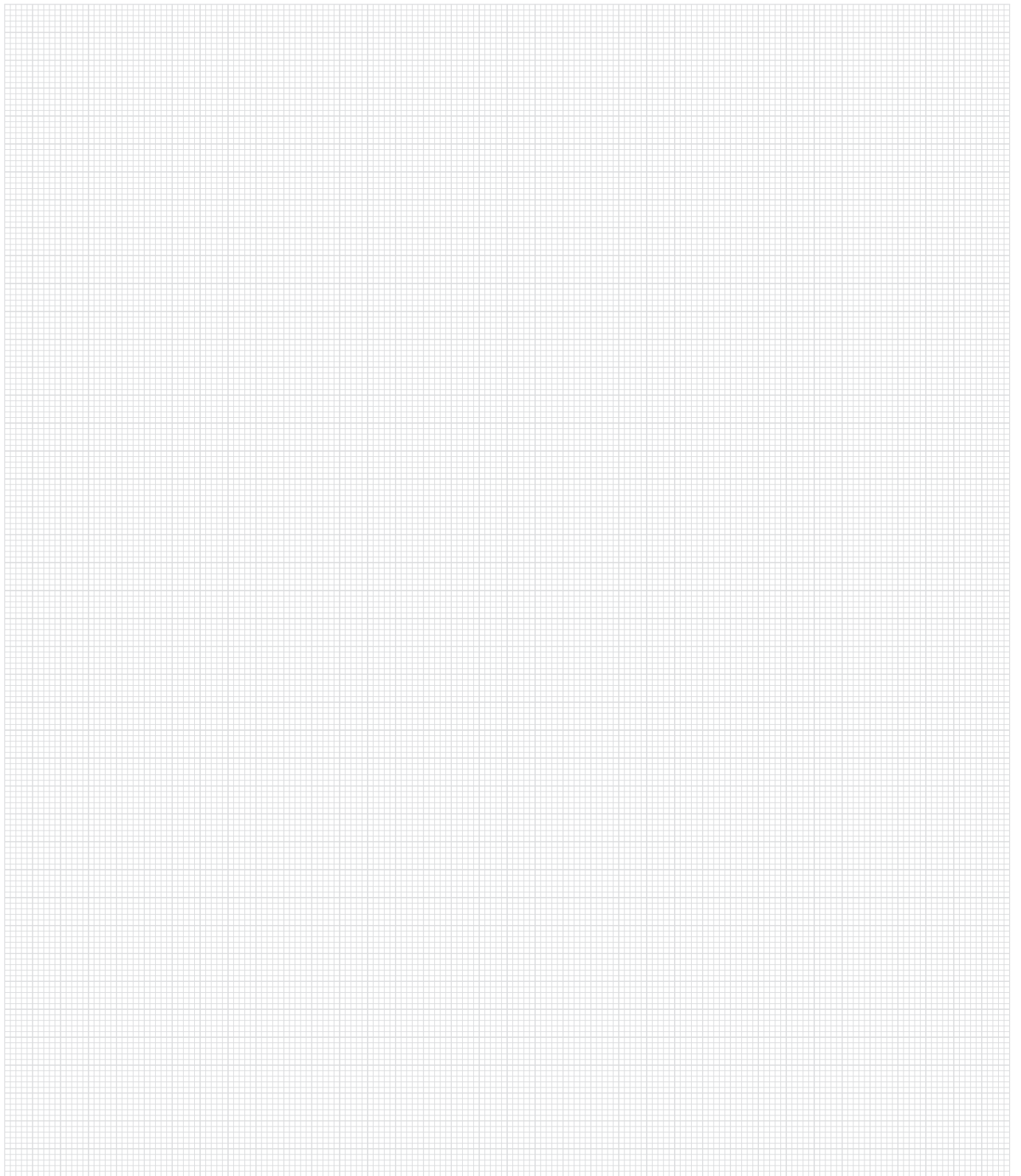

Weitere Informationen finden Sie unter
For more information see
Per maggiori informazioni visita il sito:

www.arno.de

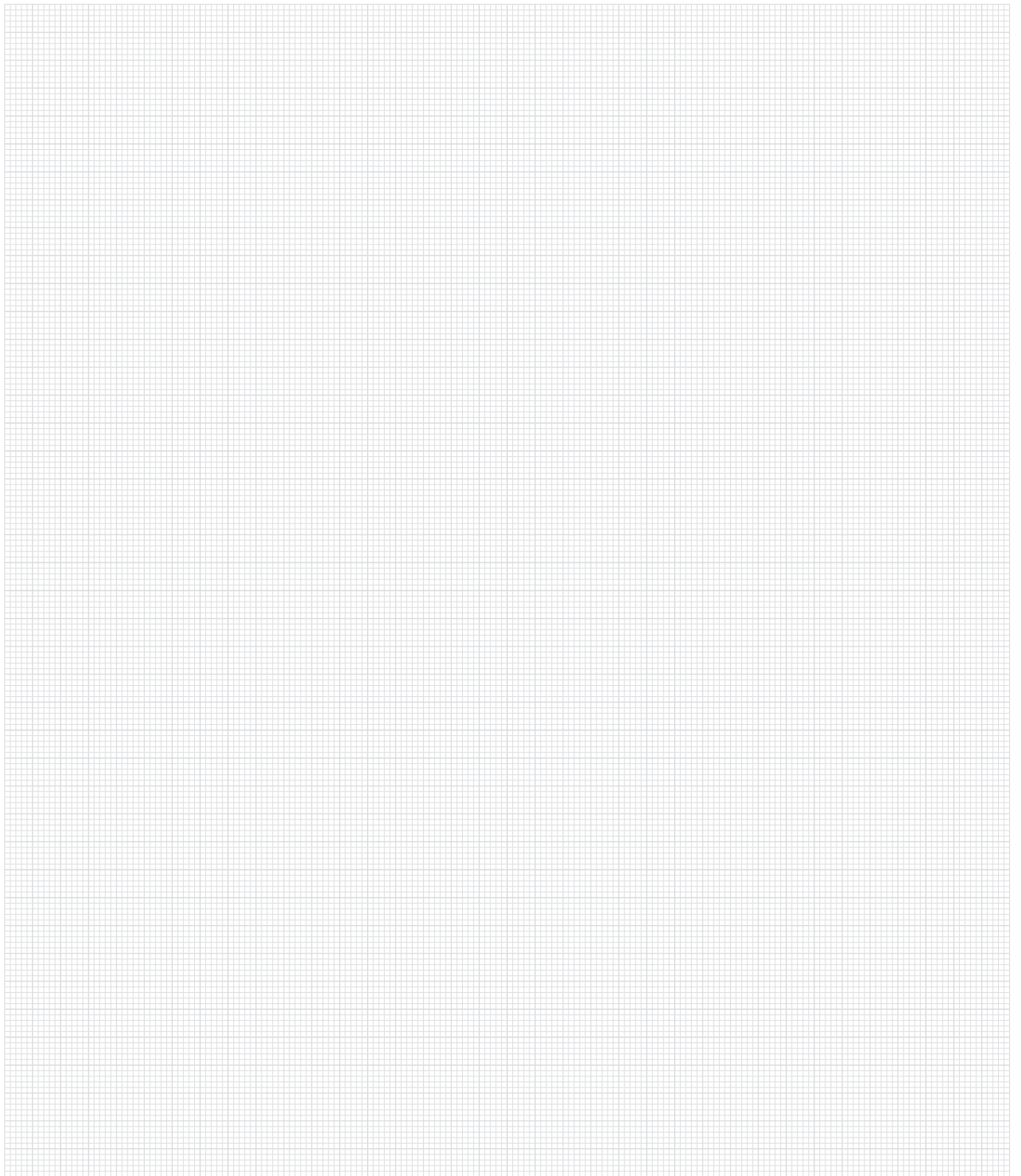

Weitere Informationen finden Sie unter
For more information see
Per maggiori informazioni visita il sito:



www.arno.de

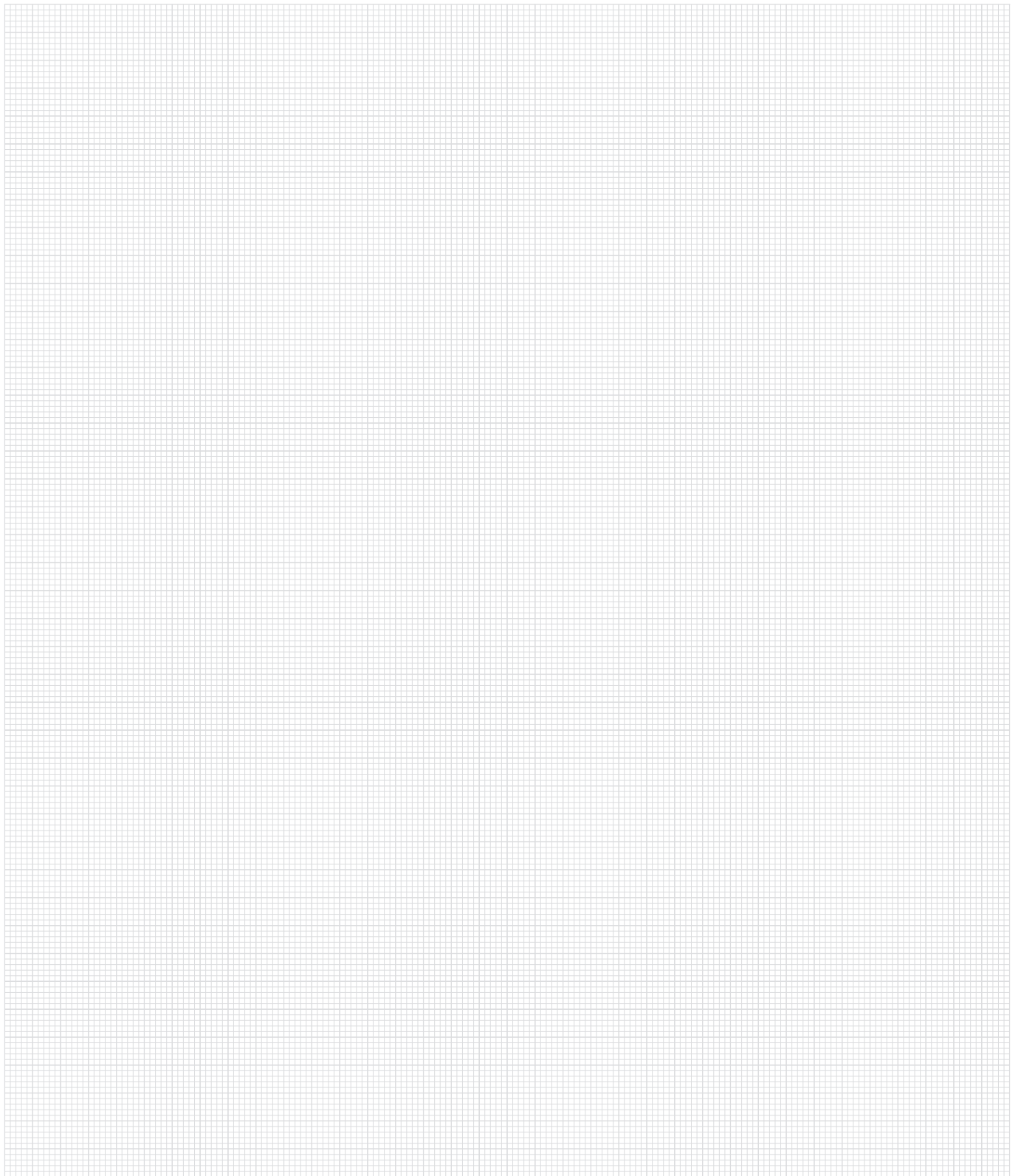

Weitere Informationen finden Sie unter
For more information see
Per maggiori informazioni visita il sito:

www.arno.de

We have a passion for precision.

Mit Leidenschaft und Begeisterung den Herausforderungen unserer Kunden zu begegnen, zu tüfteln, zu entwickeln und präzise zu fertigen – das macht ARNO®-Werkzeuge aus. Rund 70 Jahre Erfahrung fließen in jedes unserer Werkzeuge. Das ist zertifizierte Qualität und Präzision auf höchstem Niveau.

With passion and enthusiasm we face the challenges of our customers, to modify, develop and precisely manufacture – this is the way of ARNO®-Werkzeuge. Every single tool contains the knowledge and experience of over 70 years traditional tool manufacturing. That is proven quality and precision at the highest level.

Con passione ed entusiasmo affrontiamo le sfide per sviluppare una produzione precisa – così lavora ARNO®-Werkzeuge. Ogni singolo utensile contiene la conoscenza e l'esperienza di oltre 70 anni di lavorazioni. Questa è qualità e precisione al più alto livello.

The certificate is a vertical document with a blue header and footer. The header contains the TÜV SÜD Management Service logo. The main body is white with black text. The footer contains the TÜV SÜD logo and contact information. The certificate is for Karl-Heinz Arnold GmbH, certifying their Quality Management System for ISO 9001:2008. The audit was performed in 2015, and the certificate is valid until 2018.

CERTIFICATE

The Certification Body
of TÜV SÜD Management Service GmbH
certifies that

ARNO
WERKZEUGE

Karl-Heinz Arnold GmbH
Karlsbader Straße 4
73760 Ostfildern
Germany

has established and applies
a Quality Management System for

**Engineering, storage and sales of
cutting tools and workholding tools..**

An audit was performed, Report No. **70013372**.
Proof has been furnished that the requirements
according to

ISO 9001:2008

are fulfilled.

The certificate is valid in conjunction
with the main certificate from **2015-11-12** until **2018-09-14**.
Certificate Registration No.: **12 100 21067/01 TMS**.

M. Wegmann
Product Compliance Management
Munich, 2015-11-04

TÜV SÜD Management Service GmbH • Zustellungsstelle • Rabenstraße 15 • 85323 München • Germany
www.tuv-sud.de/certificate-validity-check



Werkzeuge und Schneideinsätze zum Ein- und Abstechen

Tools and inserts for parting and grooving

Utensili ed inserti di troncatura e scanalatura



Werkzeuge und Wendeschneidplatten zum Drehen und Gewindedrehen

Tooling and indexable inserts for turning and threading

Utensili ed inserti di tornitura e filettatura



Werkzeuge und Wendeschneidplatten zum Fräsen und Gewindefräsen

Milling cutters and indexable inserts for milling and thread milling

Utensili ed inserti di fresatura e di filettatura di fresatura

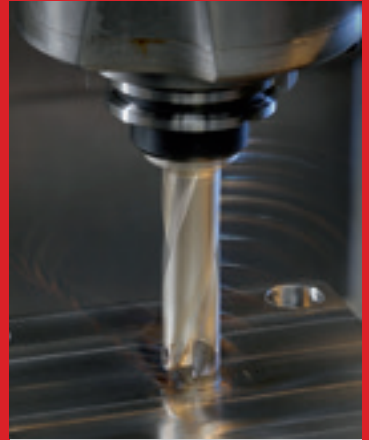

Werkzeuge und Wendeschneidplatten zum Bohren

Drilling tools and indexable inserts for drilling

Utensili ed inserti di foratura



Fordern Sie unsere weiteren Broschüren oder den Gesamtkatalog an.

For further information please ask for our complete catalogue.

Per ulteriori informazioni richiedete la raccolta cataloghi completa.

Siamo sempre al vostro servizio.



Karl-Heinz Arnold GmbH
Karlsbader Str. 4
D-73760 Ostfildern

Tel.: +49 (0)711 34 802 0
Fax: +49 (0)711 34 802 130
bestellung@arno.de
anfrage@arno.de
www.arno.de

ARNO (UK) Limited | Unit 9, 10 & 11, Sugnall Business Centre | Sugnall, Eccleshall | Staffordshire | ST21 6NF
☎ +44 01785 850 072 | ☎ +44 01785 850 076 | sales@arno.de | www.arno-tools.co.uk

ARNO Italia S.r.l | Via J.F. Kennedy 19 | 20871 Vimercate (MB)
☎ +39 039 68 52 101 | ☎ +39 039 60 83 724 | info@arno-italia.it | www.arno-italia.it

ARNO-Werkzeuge USA LLC | 1101 W. Diggins St. | US-60033 Harvard, Illinois
☎ +1 815 943 4426 | ☎ +1 815 943 7156 | info@arnousa.com | www.arnousa.com

ARNO RU Ltd. | Krassnaja Ul. 38 | RU-600015 Vladimir
☎/☎ +7 4922 541125 | ☎ +7 4922 541135 | info@arnoru.ru | www.arnoru.ru

ARNO Werkzeuge S.E.A. PTE. LTD. | 25 International Business Park | #04 – 70A German Center | SG-609916 Singapore
☎ +65 65130779 | ☎ +65 68970042 | info@arno.com.sg | www.arno.com.sg